

CONSEW

MODEL 290

THREAD TRIMMER SERIES

- TC** - Needle and Bobbin (TOP AND BOTTOM) Thread Trimmer
- W** - Needle Thread Wiper
- A** - Automatic Reverse Function
- R** - Reverse Lever
- L** - Automatic Foot Lift } (N) AIR OPERATED OR
(E) ELECTRIC OPERATED

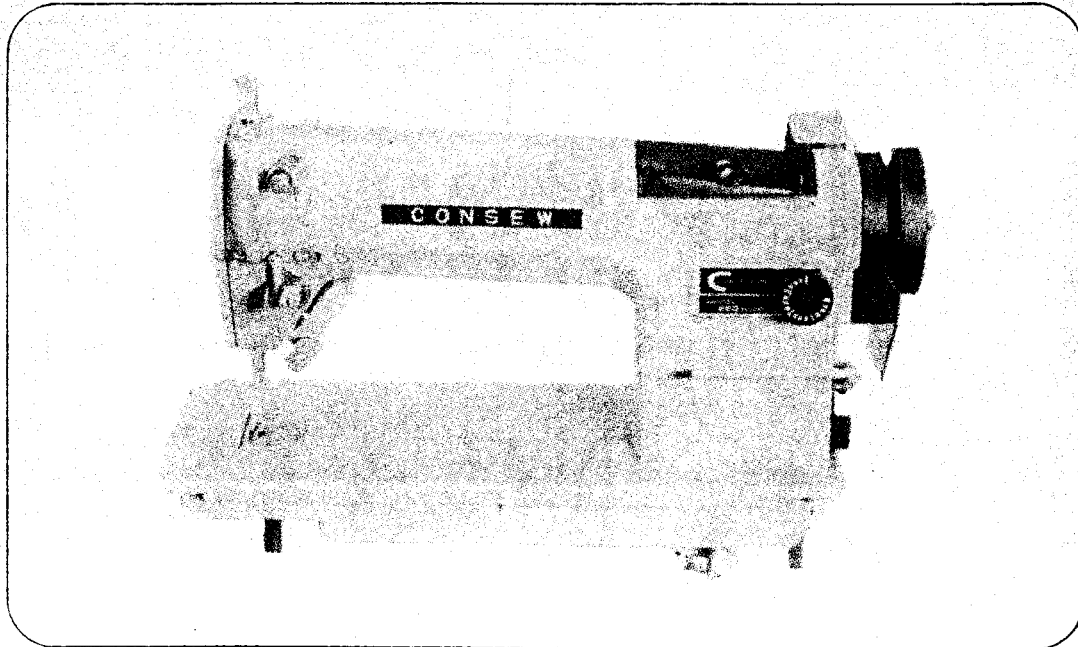

2111179-141-C

HOW TO USE THIS PARTS CATALOGUE

- 1 . This parts catalogue has been made up on the basis of the data of JAN. 1982.
- 2 . The order placed with an abbreviated part number is not acceptable. Be sure to place an order with the full REF. No. with parts name.
for ex. (correct) **AC296D** Thread take-up lever ass'y
 (wrong) **296** Thread take-up lever ass'y
- 3 . If the following symbol is provided in the remarks column, refer to the parts catalogue in accordance with the explanation of the symbols below:
* The symbol means the special part for the series model. Since the part made with this symbol differs according to the thickness of cloth, refer to the column of the subclass special parts.
- 4 . The parts are subject to change without prior notice.

目 次

CONTENTS

	頁 page
0. 仕様関係 Specification	2
1. 本体関係 Machine Body Component Parts	4
2. 上軸・針棒・天ビン関係 Top Shaft, Needle Bar, Take-up Lever	6
3. 押エ・膝上げ関係 Presser Bar, Knee Lifter	8
4. 立軸・下軸関係 Vertical Shaft, Lower Shaft	12
5. 水平・上下送り関係 Feed Rock Shaft, Feed Lifting Shaft	14
6. 給油関係 Oil Lubrication	18
7. 糸切り関係 Thread Trimmer	20
8. 返し縫イ・糸払イ Automatic Reverse Feed, Wiper	22
9. 付属品関係 Accessories	26
サブクラス専用部品 Sub Class Special Parts	28

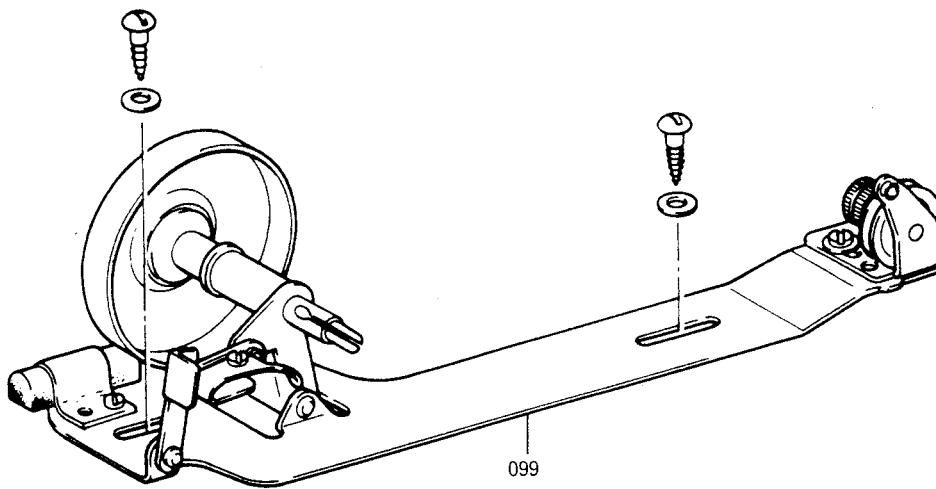
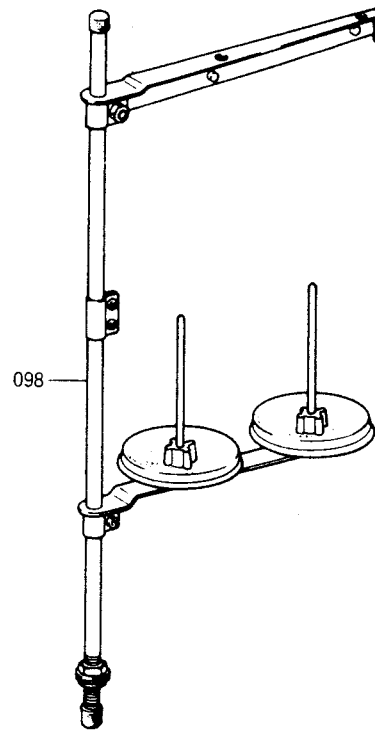
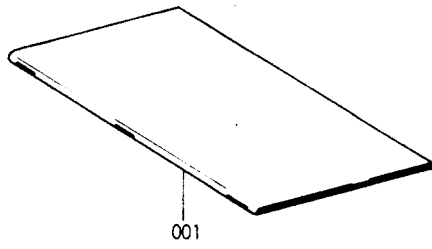

0. 仕様関係

Specification

見出番号 REF. NO.	品番 PARTS NO.	品名	PARTS NAME	個数 QTY	備考 REMARK
ACA001C " 099 " 098	2111229-111-C 2110912-410-C 0201166-130		Instruction booklet Bobbin winder Thread stand	1 1 1	
NO.	変更内容 REVISION		INTERCHANGE.	機番 SERIAL NO.	

0

1. 本体関係

Machine Body Component Parts

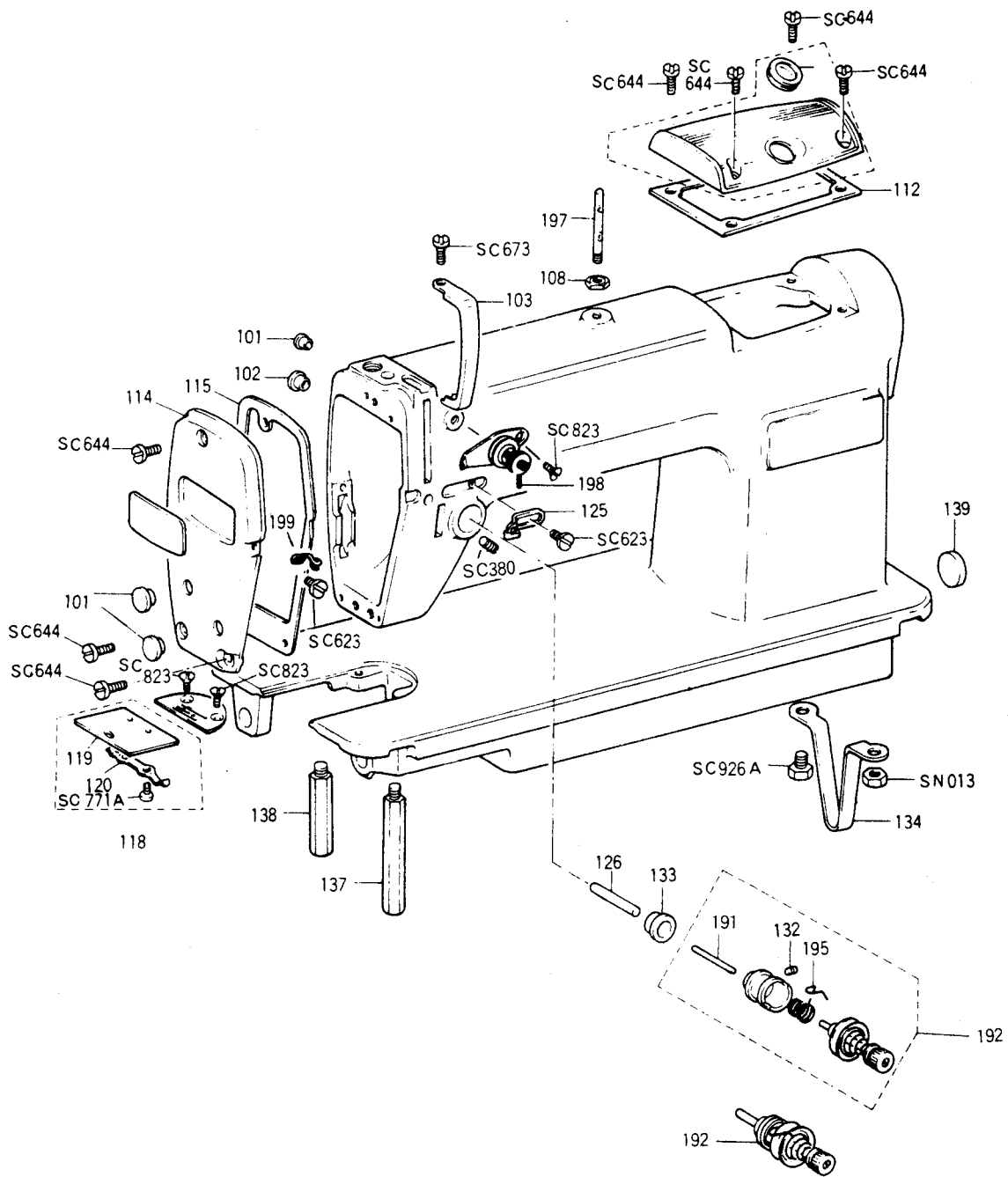

1. 本体関係

Machine Body Component Parts

見出番号 REF. NO.	品番 PARTS NO.	品名	PARTS NAME	個数 QTY	備考 REMARK
AC 101A	2120201-234-A	調節穴フタ	Rubber plug	2	
" 102A	2110201-254-A	止メネジ栓	Rubber plug	7	
" 103A	2111101-241-A	天ビンカバー	Thread take-up cover	1	
SC 673	9541104-259	丸平小ネジ (11/64)	Screw (11/64)	1	
AC 198B	2111102-301-B	補助糸調子 (組)	Supplementary tension ass'y	1	
SC 823	9013600-003	皿小ネジ (11/64)	Screw (11/64)	1	
AC 197	2111102-311	糸立棒	Thread guide pin	1	
" 108	2110602-319	ナット	Nut	1	
" 109B	2110901-210-B	アームフタ (組)	Top cover ass'y	1	
" 110A	2110901-211-A	アームフタ	Top cover	1	
" 111A	2110901-305-A	オイルゲージ窓	Oil gauge window	1	
" 112A	2110901-215-A	アームフタパッキング	Packing for top cover	1	
SC 644	9540907-247	丸平小ネジ (9/64)	Screw (9/64)	4	
AC 114	2111101-231	面板	Face plate	1	
" 101A	2120201-234-A	調節穴フタ	Rubber plug	2	
" 115A	2111101-232-A	面板パッキング	Packing for face	1	
SC 644	9540907-247	丸平小ネジ (9/64)	Screw (9/64)	3	
AC 199	2121602-315-A	面板糸掛ケ	Thread guide	1	
SC 623	9540901-101	丸平小ネジ (9/64)	Screw (9/64)	1	
AC 118C	2110213-120-C	滑り板 (組)	Slide plate ass'y	1	
" 119A	2110213-121-A	滑り板	Slide plate	1	
" 120	1110301-522	滑り板バネ	Slide plate spring	1	
SC 771A	9013400-021-A	締メネジ (3/32)	Screw (3/32)	2	
AC 122F	2110303-112-F	針板	Needle plate	1	*
SC 823	9013600-003	丸皿小ネジ (11/64)	Screw (11/64)	2	
AC 125C	2110602-313-C	糸掛ケ曲り板	Thread guide right	1	
SC 623	9540901-101	丸平小ネジ (9/64)	Screw (9/64)	1	
AC 126C	2110902-356-C	糸ユルメピン (大)	Thread tension release pin (L)	1	
SC 380	9501508-276	止メネジ (15/64)	Screw (15/64)	1	
AC 192	2121602-350	糸調子 (組)	Thread tension unit	1	*
" 191	2121602-356	糸ユルメピン	Thread tension release pin	1	
" 195	2111102-354	糸取りバネ	Thread take-up spring	1	
" 132	2110202-358	糸調子棒止メネジ (9/64)	Screw (9/64)	1	
" 133	2110202-361	糸調子スカートゴム	Packing for thread tension	1	
" 134	2210101-151	脚 (A)	Bed leg (A)	1	
SC 926A	9026900-030-A	六角ホルト (M8 P=1.25)	Screw (M8 P=1.25)	1	
SN 013	9420201-119	ナット	Nut	1	
AC 137	2210101-152-A	脚 (B)	Bed leg (B)	1	
" 138	2210101-153-A	脚 (C)	Bed leg (C)	1	
" 139	0252037-114	コードブッシュ	Plug for bed hole	1	
NO.	変更内容 REVISION		互換性 INTERCHANGE.	機番 SERIAL NO.	

1

2. 上軸・針棒・天ビン関係

Top Shaft, Needle Bar, Take-up Lever

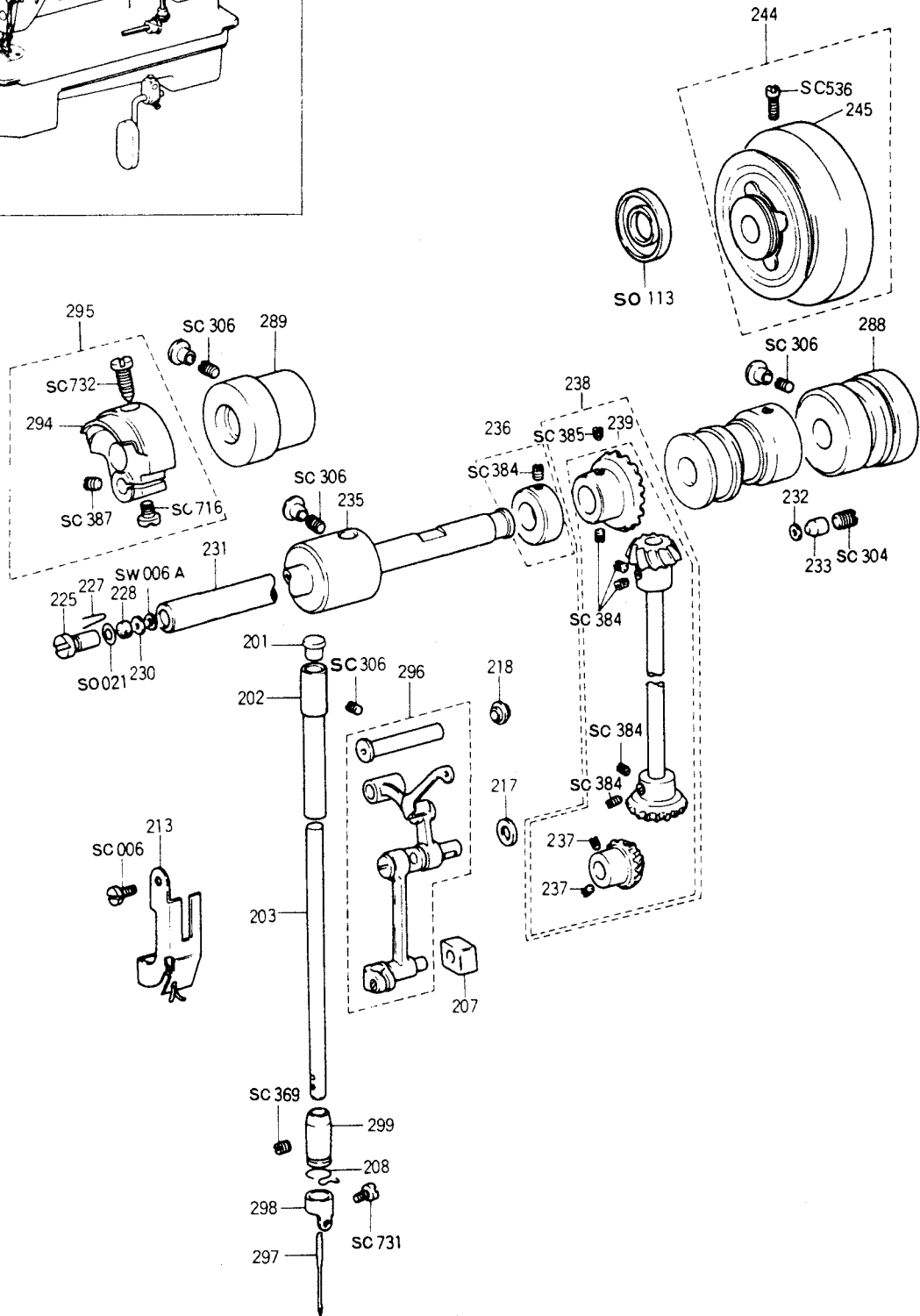
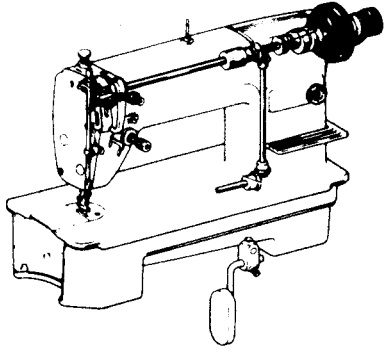

2. 上軸・針棒・天ビン関係 Top Shaft, Needle Bar, Take-up Lever

見出番号 REF. NO.	品番 PARTS NO.	品名	PARTS NAME	個数 QTY	備考 REMARK
AC 201D	2110202-115-D	針棒メタルフタ	Plastic plug	1	
" 202D	2110202-113-D	針棒メタル (上)	Needle bar bushing upper	1	
" 203C	2111112-111-C	針 棒	Needle bar	1	*
" 299F	2110202-114-F	針棒メタル (下)	Needle bar bushing lower	1	*
SC 369	9501501-256	止メネジ (15/64)	Screw (15/64)	2	
AC 207B	2110202-122-B	針棒角ゴマ	Needle bar slide block	1	
" 208A	2110602-116-A	下糸掛ケ	Thread guide	1	
" 298	2121002-116	針棒糸掛ケ	Needle bar thread guide	1	
SC 731	9540816-279	丸平小ネジ (1/8)	Screw (1/8)	1	
AC 297	2110402-193	針 #11	Needle #11	1	*
" 213A	2111106-391-A	針棒注油板	Retainer plate for oil wick	1	
SC 006	9013200-006	丸平小ネジ (9/64)	Screw (9/64)	1	
AC 296D	2111102-021-D	天ビン (組)	Thread take-up lever ass'y	1	*
SC 306	9015600-006	止メネジ (15/64)	Screw (15/64)	1	
AC 217B	2210102-215-B	針棒クランク軸ワッシャー	Needle bar crank washer	1	
" 218	2111102-225	天ビン油切り	Oil cut for thread take-up	1	
" 295A	2121602-130-A	天ビンクランク (組)	Take-up lever crank ass'y	1	*
" 294A	2121602-131-A	天ビンクランク	Take-up lever crank	1	
SC 732	9013400-026	天ビンクランク止メネジ (9/32)	Screw (9/32)	1	
" 716	9541604-256	丸平小ネジ (1/4)	Screw (1/4)	1	
" 387	9501604-256	止メネジ (1/4)	Screw (1/4)	1	
AC 289	2110914-220	上軸メタル前 (組)	Top shaft front bushing ass'y	1	
SC 306	9015600-006	止メネジ (15/64)	Screw (15/64)	1	
AC 225A	2110904-123-A	給油調節弁	Oil adjusting valve	1	
SO 021	9060100-021	Oリング	Rubber packing	1	
AC 227	2110904-124	弁圧接バネ	Oil adjusting valve spring	1	
" 228A	2110904-125-A	フェルト	Felt	1	
SW 006A	9030100-006-A	平 座 金	Washer	1	
AC 230	2110904-129	オイル調節ゴム	Oil adjusting rubber	1	
" 231H	2111114-111-H	上 軸	Top shaft	1	
" 232	2110904-127	プラグワッシャー	Washer	1	
" 233A	2110604-118-A	上軸プラグ	Top shaft plug	1	
SC 304	9015600-004	止メネジ (5/16)	Screw (5/16)	1	
AC 235C	2110904-113-C	上軸メタル中	Top shaft center bushing	1	
SC 306	9015600-006	止メネジ (15/64)	Screw (15/64)	1	
AC 236A	2110604-140-A	上軸カラー (組)	Top shaft collar ass'y	1	
SC 384	9501602-276	止メネジ (1/4)	Screw (1/4)	1	
AC 238	2110204-012	ギヤー (組)	Gear ass'y	1	
" 239	2110204-101	ギヤー (組)	Gear ass'y	1	
SC 384	9501602-276	止メネジ (1/4)	Screw (1/4)	7	
" 385	9501603-256	止メネジ (1/4)	Screw (1/4)	1	
AC 288	2110904-260	上軸メタル後 (組)	Top shaft rear bushing	1	
SC 306	9015600-006	止メネジ (15/64)	Screw (15/64)	1	
SO 113	9060200-013	オイルシール	Oil seal	1	
AC 244E	2110944-150-E	ハズミ車 (組)	Hand wheel ass'y	1	
" 245D	2110944-151-D	ハズミ車	Hand wheel	1	
SC 536	9531507-276	平小ネジ (15/64)	Screw (15/64)	2	
NO.	変更内容 REVISION		互換性 INTERCHANGE.	機番 SERIAL NO.	

2

3. 押エ・糸ユルメ・膝上げ関係

Presser Bar, Tension Release, Knee Lifter

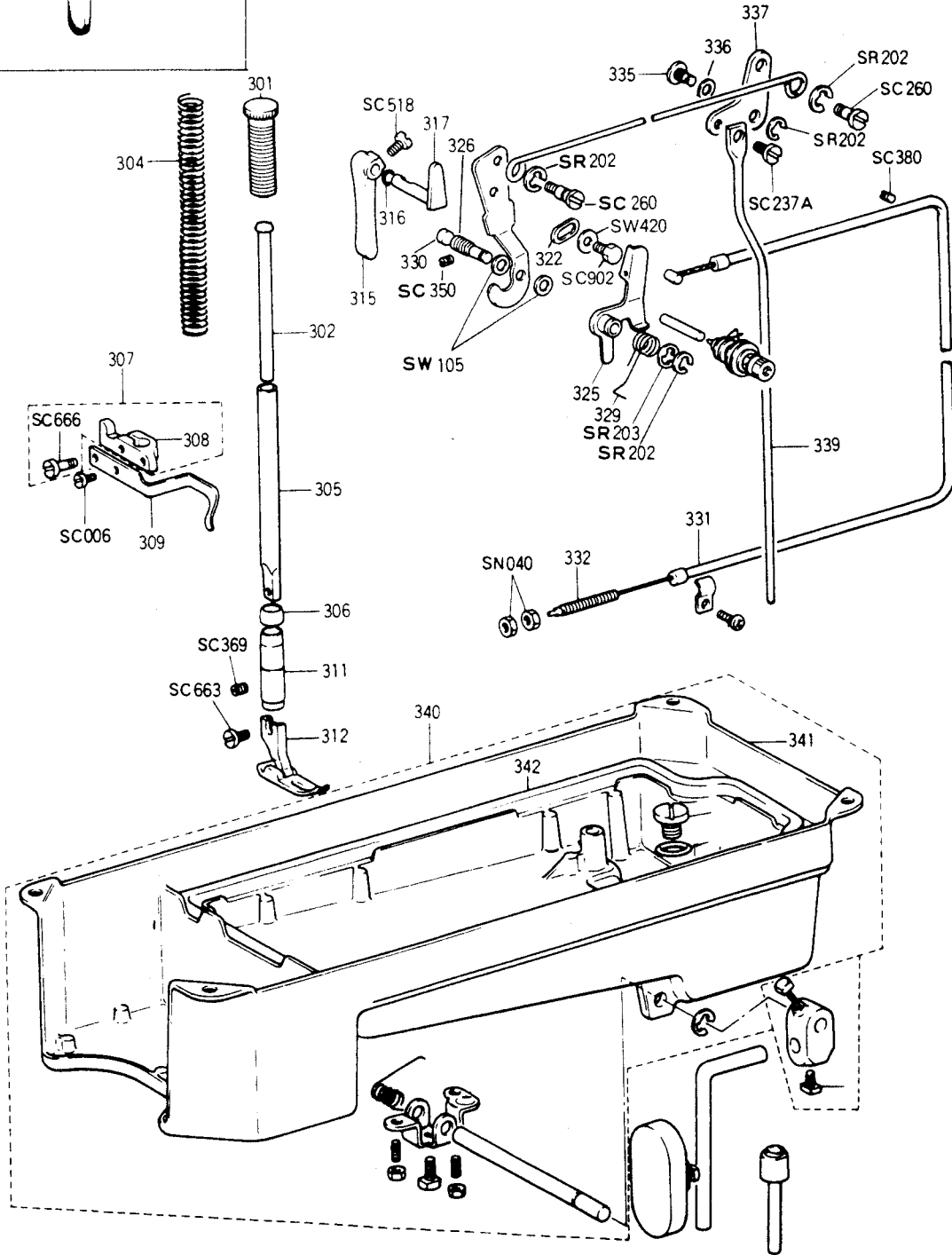
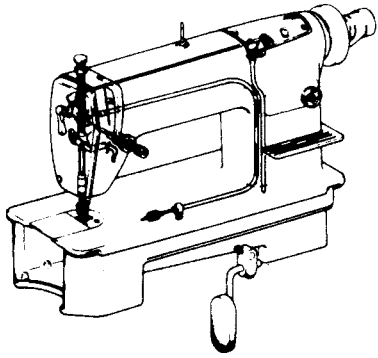

3. 押エ・糸ユルメ・膝上げ関係

Presser Bar, Tension Release, Knee Lifter

見出番号 REF. NO.	品番 PARTS NO.	品名	PARTS NAME	個数 QTY	備考 REMARK
AC 301B	2110203-271-B	押エ調節ネジ	Pressure regulating screw	1	
302C	2110203-272-C	押エ調節ネジロッド	Pressure regulating bar	1	
" 304	2110903-213	押エバネ	Presser spring	1	
" 305A	2110203-211-A	押エ棒	Presser bar	1	
" 306	2111103-223	押エ棒油切り	Oil cut for presser bar	1	
" 307	2111103-230	押エ棒抱キ(組)	Presser bar guide bracket ass'y	1	
" 308	2111103-231	押エ棒抱キ	Presser bar guide bracket	1	
" 309	2111102-316	糸案内曲り板	Thread guide front	1	
SC 666	9541102-259	丸平小ネジ (11/64)	Screw (11/64)	1	
SC 006	9013200-006	ナベ小ネジ (9/64)	Screw (9/64)	1	
AC 311A	2120403-215-A	押エ棒メタル	Presser bar bushing	1	
SC 369	9501501-256	止メネジ (15/64)	Screw (15/64)	1	
AC 312D	2110103-220-D	押エ(組)	Presser foot ass'y	1	*
SC 663	9540926-241	丸平小ネジ (9/64)	Screw (9/64)	1	
AC 315A	2111103-351-A	押エ上げ	Presser bar lifter lever	1	
SO 110	9060200-010	オイルシール	Oil seal	1	
AC 317B	2111103-355-B	押エ上げクランク	Presser bar lifter lever crank	1	
SC 518	9531102-247	平小ネジ (11/64)	Screw (11/64)	1	
AC 319A	2111103-256-A	引き上げリンク	Knee lifter plate	1	
SC 260	9018500-030	段ネジ (3/16)	Pivot screw (3/16)	1	
SR 202	9080200-002	E型止メ輪	Snap ring	1	
AC 322A	2111103-412-A	糸ユルメ調節支エ	Retainer	1	
SW 420	9120300-418	平座金	Washer	1	
SC 902	9580902-118	六角ボルト (9/64)	Screw (9/64)	1	
AC 325B	2111103-411-B	糸ユルメ	Tension release plate	1	
" 326B	2111103-251-B	引上げリンク軸	Knee lifter plate shaft	1	
SC 350	9501101-256	止メネジ (11/64)	Screw (11/64)	1	
SW 105	9030100-105	平座金	Washer	2	
SR 202	9080200-002	E型止メ輪	Snap ring	1	
SR 203	9080200-003	E型止メ輪	Snap ring	1	
AC 329A	2111103-414-A	糸ユルメバネ	Tension release spring	1	
" 330	2111101-254	引上げリンク軸止メネジ栓	Rubber plug	1	
" 331A	0252032-178-A	糸ユルメケーブル	Tension release cable	1	
" 332A	0252042-182-A	ケーブルエンド	Cable end	1	
SN 040	9172500-104	ナット	Nut	2	
SC 380	9501508-276	止メネジ (15/64)	Screw (15/64)	1	
AC 334C	2111103-253-C	膝上げロッド	Knee lifter rod	1	
" 335	2111103-255	膝上げリンク軸	Knee lifter link shaft	1	
" 336	2111103-269	パッキング	Packing	1	
SC 260	9018500-030	段ネジ (3/16)	Pivot screw (3/16)	1	
AC 337	2111103-252	膝上げリンク	Knee lifter link	1	
SR 202	9080200-002	E型止メ輪	Snap ring	1	
SC 237A	9015500-081-A	段ネジ (3/16)	Pivot screw (3/16)	1	
AC 339	2111103-258	膝上げ押し棒	Knee lifter connecting push rod	1	
" 340F	2111101-300-F	オイルパン(組)	Oil pan ass'y	1	◆
" 341B	2111101-311-B	オイルパン	Oil pan	1	◆
" 342D	2110601-312-D	オイルパンパッキング	Oil pan gasket	1	◆
NO.	変更内容 REVISION		互換性 INTERCHANGE.	機番 SERIAL NO.	

3

3. 押エ・糸ユルメ・膝上げ関係

Presser Bar, Tension Release, Knee Lifter

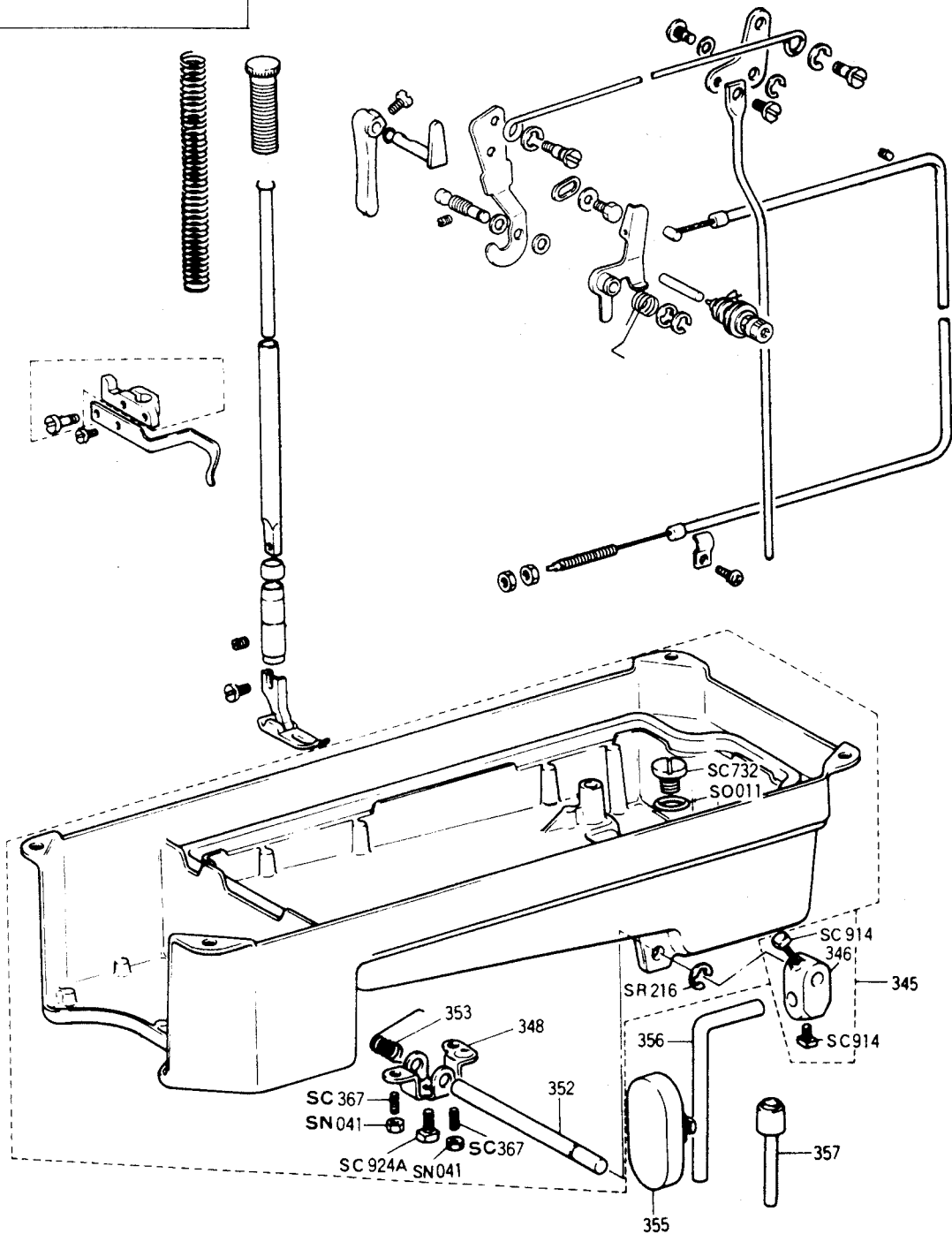
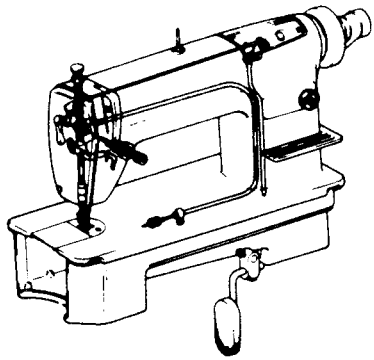

3. 押エ・糸ユルメ・膝上げ関係

Presser Bar, Tension Release, Knee Lifter

見出番号 REF. NO.	品番 PARTS NO.	品名	PARTS NAME	個数 QTY	備考 REMARK
SO 011	9060100-011	Oリング	Drain packing	1	◆
SC 732	9016400-023	丸平小ネジ (M8 P=1.25)	Drain screw (M8 P=1.25)	1	◆
AC 345E	2110203-340-E	膝当棒支持金 (組)	Knee lifter bracket ass'y	1	◆
" 346C	2110203-341-C	膝当棒支持金	Knee lifter bracket	1	◆
SC 914	9592002-159	四角ボルト (5/16)	Screw (5/16)	2	◆
AC 348	2111103-344	膝上げ制御体	Knee lifter controller	1	◆
SC 924A	9024000-002-A	四角ボルト (5/16)	Screw (15/64)	1	◆
" 367	9501208-256	止メネジ (3/16)	Screw (3/16)	2	◆
SN 041	9410125-107	ナット	Nut	2	◆
AC 352	2111103-363	押エ上げ軸	Knee lifter shaft	1	◆
" 353	2111103-364	押エ上げ軸バネ	Knee lifter shaft spring	1	◆
SR 216	9080200-016	E型止メ輪	Snap ring	1	◆
AC 355C	2110213-303-C	膝当板 (組)	Knee lifter pad ass'y	1	◆
" 356D	2110203-342-D	膝当棒	Knee lifter arm	1	◆
" 357	2111103-366	押エ上げ棒カサ	Knee lifter plunger	1	◆

NO.	変更内容 REVISION	互換性 INTERCHANGE.	機番 SERIAL NO.

4. 立軸・下軸関係

Vertical Shaft, Lower Shaft

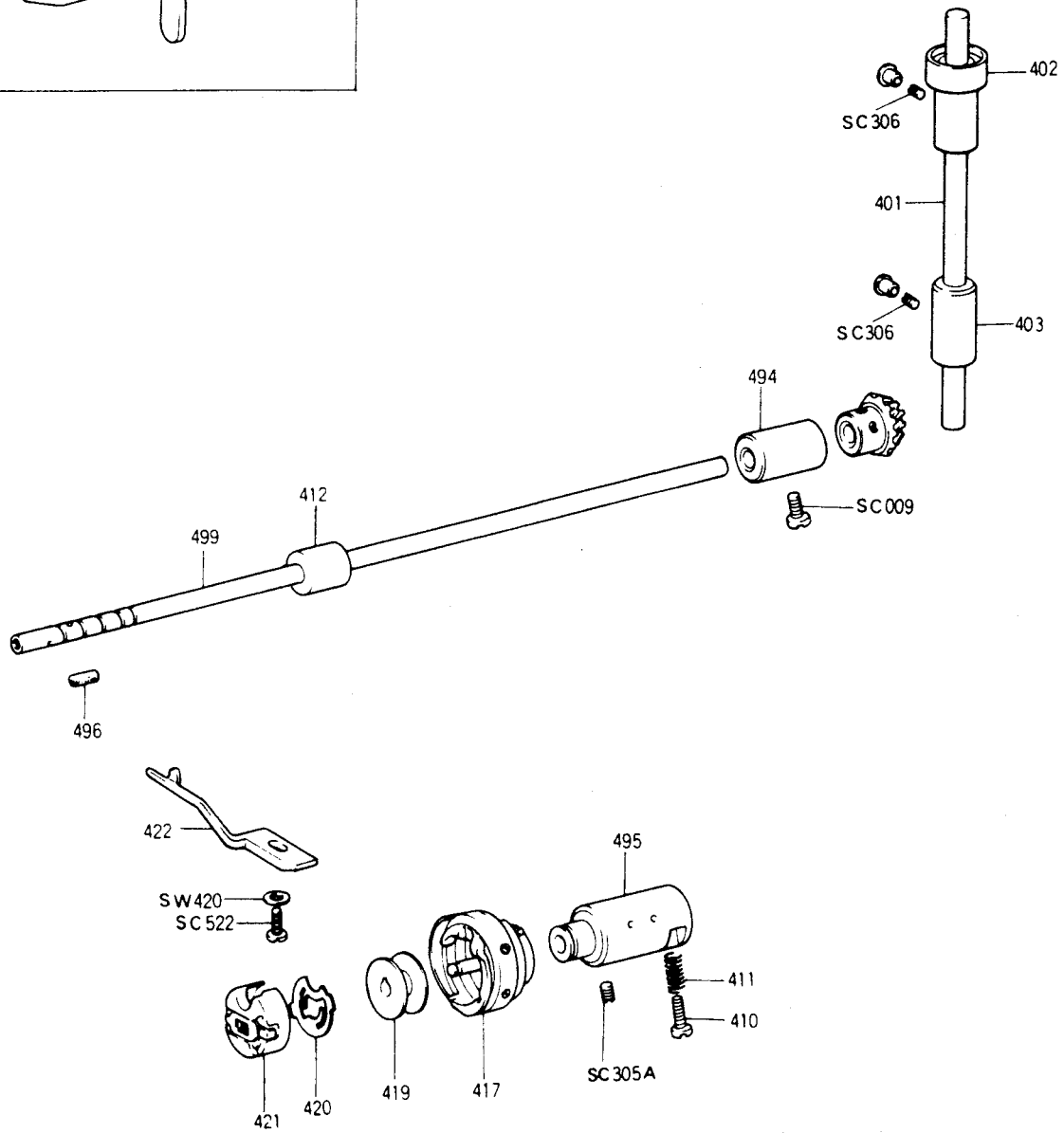
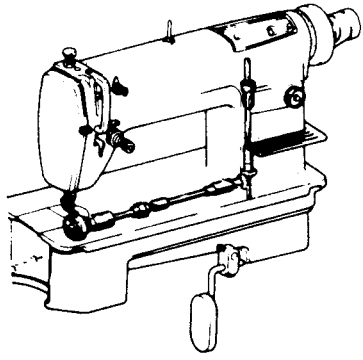

4. 立軸・下軸関係

Vertical Shaft, Lower Shaft

見出番号 REF. NO.	品番 PARTS NO.	品名	PARTS NAME	個数 QTY	備考 REMARK
AC 401A	2110904-241-A	立 軸	Vertical shaft	1	
" 402A	2110204-242-A	立軸メタル上	Vertical shaft bushing upper	1	
SC 306	9015600-006	止メネジ (15/64)	Screw (15/64)	1	
AC 403A	2110204-243-A	立軸メタル下	Vertical shaft bushing lower	1	
SC 306	9015600-006	止メネジ (15/64)	Screw (15/64)	1	
AC 499B	2111104-211-B	下 軸	Lower shaft	1	
" 496	2111116-366	下軸フェルト	Oil felt	1	
" 495A	0252052-154-A	下軸メタル前	Lower shaft bushing front	1	
SC 305A	9015600-005-A	止メネジ (15/64)	Screw (15/64)	1	
AC 410B	2110616-214-B	カマ給油弁軸	Oil adjusting screw	1	
" 411C	2110606-233-C	カマ給油弁軸バネ	Oil adjusting spring	1	
" 412A	2111104-213-A	下軸メタル中	Lower shaft bushing center	1	
" 494A	2110204-214-A	下軸メタル後	Lower shaft bushing rear	1	
SC 009	9013200-009	ナベ小ネジ (15/64)	Screw (15/64)	1	
AC 417C	2111004-310-C	大ガマ (組)	Rotary hook ass'y	1	*
" 419A	2110114-321-A	AL ボビン	AL bobbin	1	
" 420	2111104-311	ボビンケース底バネ	Bobbin case bottom spring	1	
" 421A	2110604-301-A	ボビンケース (組)	Bobbin case ass'y	1	
" 422B	2110904-315-B	中 釜 止 メ	Hook retainer	1	
SC 522	9531104-267	平小ネジ (11/64)	Screw (11/64)	1	
SW 420	9120300-418	平 座 金	Washer	1	
NO.	変 更 内 容 REVISION		互換性 INTERCHANGE.	機 番 SERIAL NO.	

4

5. 水平・上下送り関係

Feed Rock Shaft, Feed Lifting Shaft

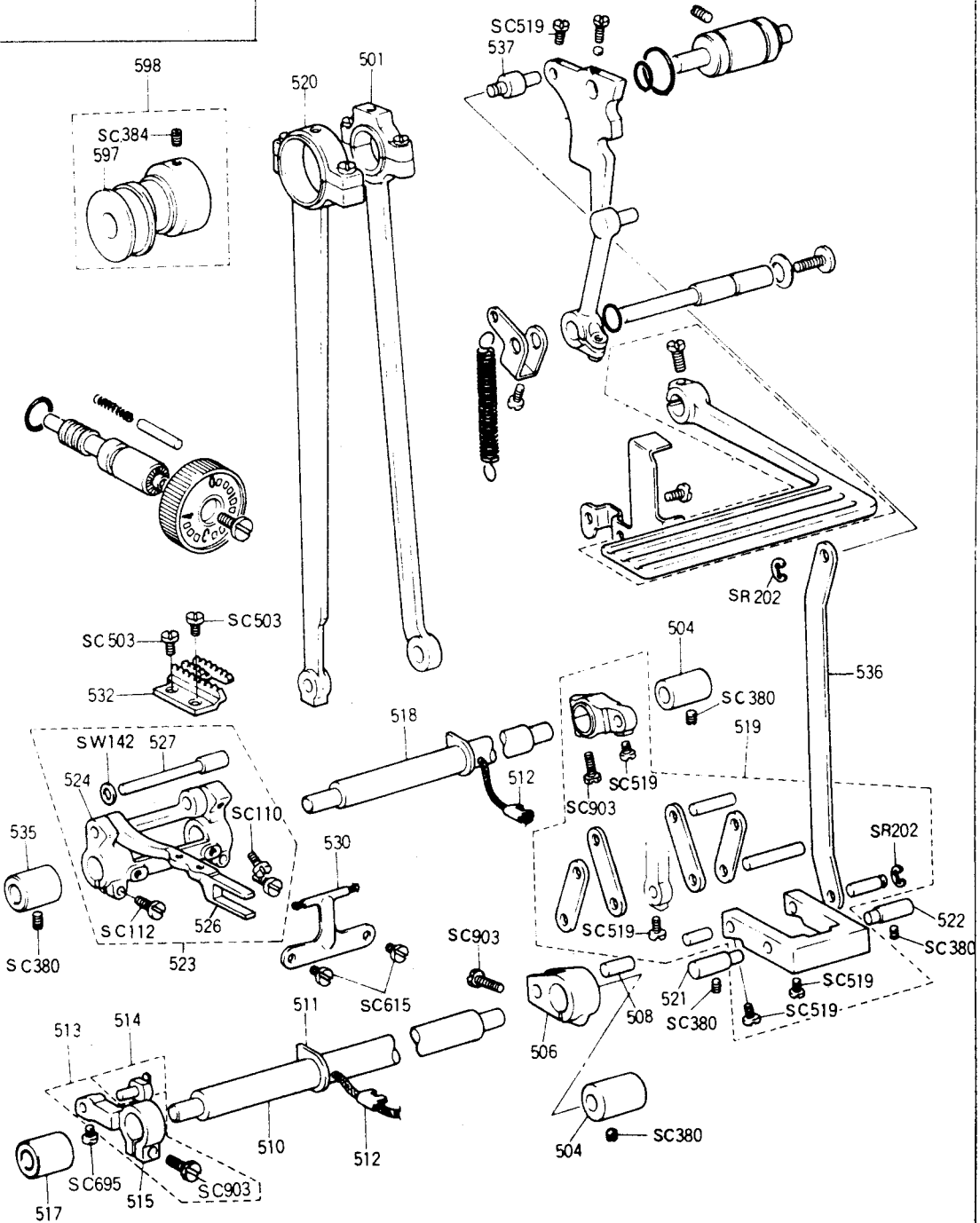
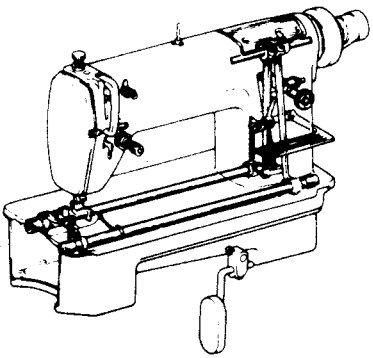

5. 水平・上下送り関係

Feed Rock Shaft, Feed Lifting Shaft

見出番号 REF. NO.	品番 PARTS NO.	品名	PARTS NAME	個数 QTY	備考 REMARK
AC 538B	2111115-327-B	送り調節カム	Feed regulator cam	1	
AC 540	2110105-325	送り調節器締ネジ当金	Soft plug	1	
SC 519	9531102-256	平小ネジ (1/8)	Screw (11/64)	1	
AC 599	0252013-320	送り調節軸 (組)	Feed regulator stud ass'y	1	
SC 306	9015600-006	止メネジ (1/8)	Screw (15/64)	1	
SO 007	9060100-007	Oリング (小)	Rubber packing	1	
" 019	9060100-019	Oリング (大)	Rubber packing	1	
AC 543A	0252013-150-A	逆縫腕 (組)	Feed regulator lever ass'y	1	
" 590	0252013-159	逆縫腕ラバー	Rubber of feed regulator lever	1	
SR 213	9080200-113	E型止メ輪	Snap ring E	1	
" 544	2111105-341	逆縫腕バネ掛ケA	Spring retainer plate	1	
SC 108	9013800-008	バインド小ネジ (3/16)	Screw (3/16)	1	
AC 546	0252023-136	逆縫レバーバネ	Spring for feed regulator lever	1	
" 547D	2110905-304-D	逆縫レバー (組)	Feed regulator lever ass'y	1	
" 548C	2110905-334-C	逆縫レバー	Feed regulator lever	1	
SC 704	9541220-107	丸平小ネジ (3/16)	Screw (3/16)	1	
AC 550A	2111105-335-A	逆縫腕軸	Feed regulator lever shaft	1	
SO 007	9060100-007	Oリング	Rubber packing	1	
SW 302	9030400-001	座金	Washer	1	
SC 694	9541208-107	丸平小ネジ (3/16)	Screw (3/16)	2	
AC 553B	0252013-134-B	レバーストッパー	Lever stopper	1	
SC 517	9531102-219	平小ネジ (11/64)	Screw (11/64)	2	
AC 554	2111105-350	送りダイヤル (組)	Feed regulator dial ass'y	1	*
" 556B	2110905-356-B	送りダイヤルスクリュー	Feed regulator dial shaft	1	
SC 685	9541203-247	丸平小ネジ (3/16)	Screw (3/16)	1	
SO 018	9060100-018	Oリング	Rubber packing	1	
AC 559C	2110305-353-C	送りダイヤルピン	Dial pin	1	
" 560A	2110105-354-A	送りダイヤルバネ	Dial spring	1	
NO.	変更内容 REVISION		互換性 INTERCHANGE.	機番 SERIAL NO.	

6. 給油関係

Oil Lubrication

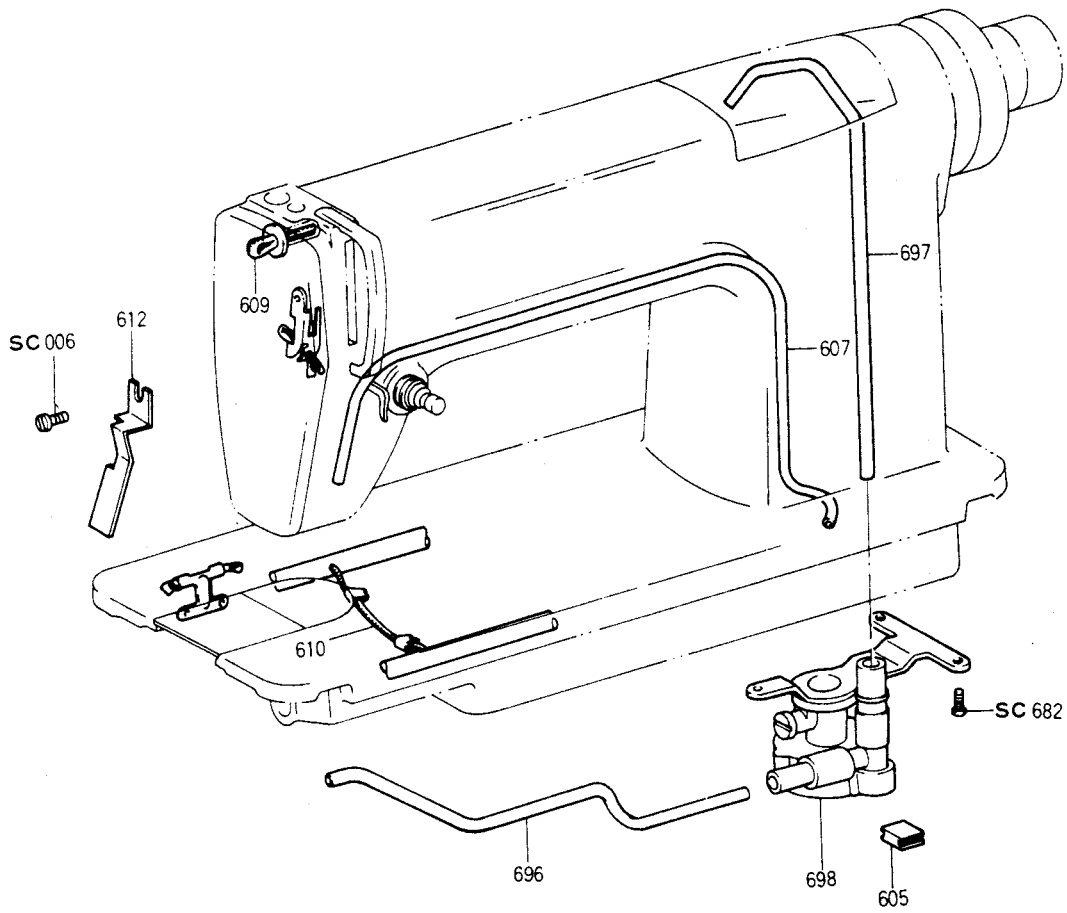

6. 給油関係

Oil Lubrication

見出番号 REF. NO.	品番 PARTS NO.	品名	PARTS NAME	個数 QTY	備考 REMARK
AC 698	2111136-110	オイルポンプボディー (組)	Oil pump body ass'y	1	
SC 682	9541201-256	丸平小ネジ (3/16)	Screw (3/16)	3	
AC 605C	2110206-116-C	オイルパンマグネット	Magnet	1	
" 697	2111116-147	上軸オイルパイプ	Upper oil feed pipe	1	
" 607C	2110906-149-C	ビニールパイプ (組)	Oil returning tube	1	
" 696	2111136-144	カマ給油パイプ	Lower oil feed pipe	1	
" 609C	2110906-311-C	天ビン支エ軸用ウイック	Thread take-up crank stud wick	1	
" 610	2110216-321	送り軸ウイック	Feed shaft wick	1	
" 612	2111106-423	油戻シパイプ止メ金	Oil tube retainer	1	
SC 006	9013200-006	ナベ小ネジ (9/64)	Screw (9/64)	1	
				1	
NO.	変更内容 REVISION	互換性 INTERCHANGE.	機番 SERIAL NO.		

7. 糸切り関係

Thread Trimmer

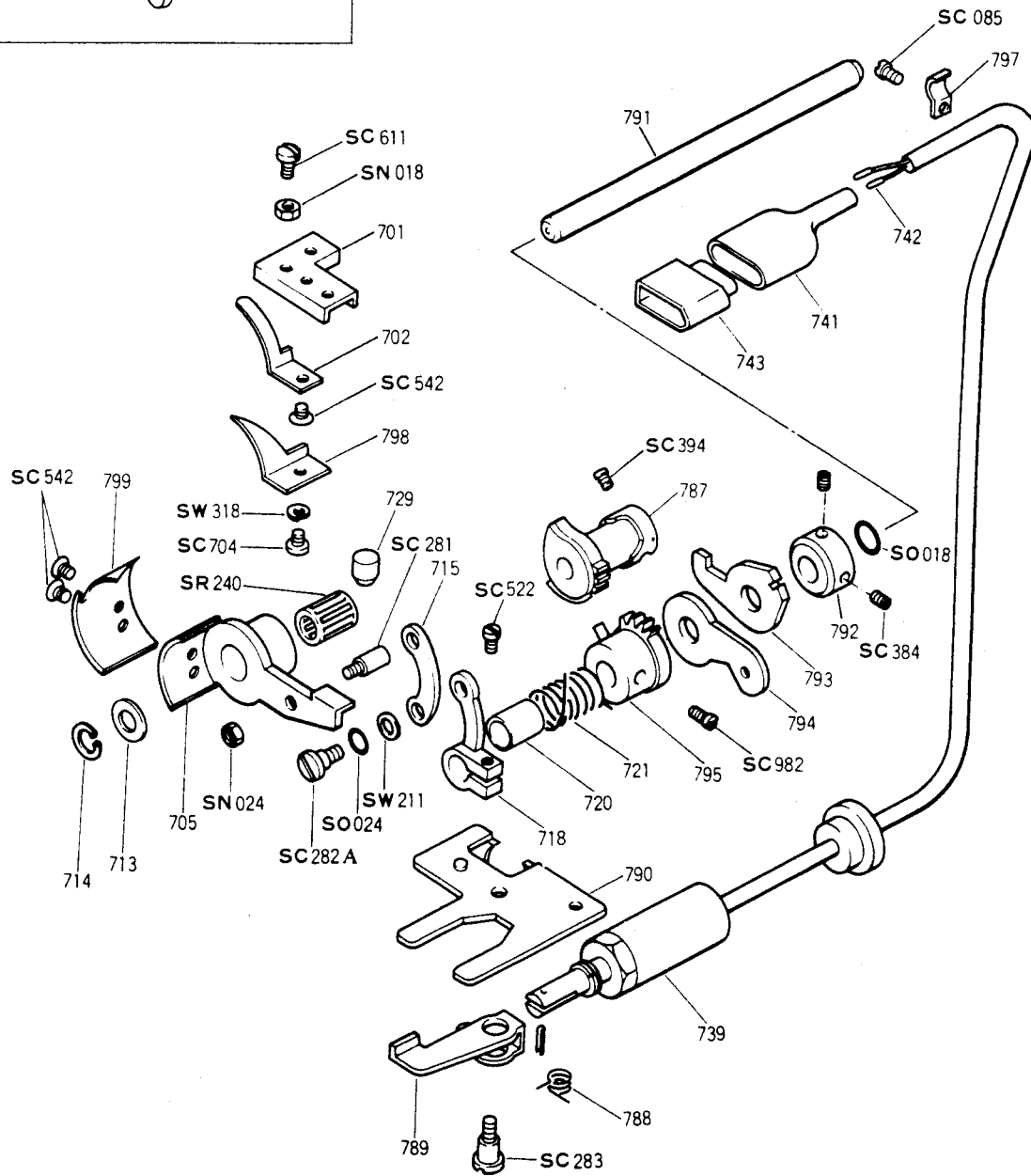
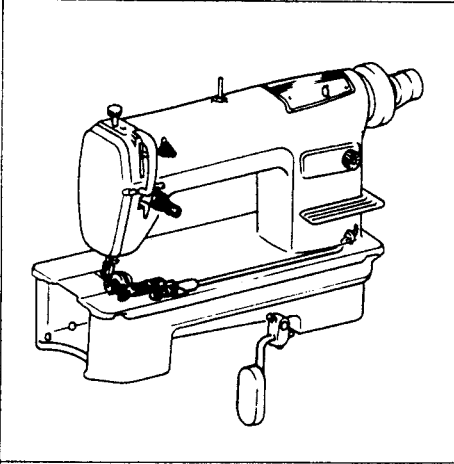

7. 糸切り関係

Thread Trimmer

見出番号 REF. NO.	品番 PARTS NO.	品名	PARTS NAME	個数 QTY	備考 REMARK
AC 701D	0252052-142-D	ナイフホルダー	Knife holder	1	
" 702B	0252052-141-B	ナイフ	Stationary knife	1	
SC 542	9550902-267	皿小ネジ (3/64)	Screw (9/64)	1	
" 611	9540802-102	丸平小ネジ (1/8)	Screw (1/8)	1	
SN 018	9440081-106	ナット	Nut	1	
AC 798	0252052-164	糸押工板	Thread restraining plate	1	
SW 318	9130500-318	バネ座金	Spring washer	1	
SC 704	9541220-107	丸平小ネジ (3/64)	Screw (3/16)	1	
AC 799	0252072-145	キャッチャー	Moving blade	1	
" 705E	0252042-146-E	キャッチャーホルダー	Arm for moving blade	1	
SC 542	9550902-267	皿小ネジ (3/64)	Screw (9/64)	1	
SR 240	9070200-018	キャッチャーホルダーベアリング	Bearing	1	
AC 713	0252012-171	ホルダーワッシャー(前)	Washer front	1	
" 714	0252012-156	C型止メ輪	Snap ring C	1	
SC 281	9018500-033	段ネジ	Pivot screw	1	
SN 024	9440112-119	ナット	Nut	1	
AC 715A	0252052-116-A	連結リンク	Connecting link	1	
SC 282A	9015500-114-A	段ネジ	Pivot screw	1	
SO 024	9060100-024	Oリング	"O" ring	1	
SW 211	9030100-211	ナイロンワッシャー	Nylon washer	1	
AC 718B	0252052-341-B	糸切りレバー	Thread trimmer lever	1	
SC 522	9531104-267	平小ネジ (1/64)	Screw (11/64)	1	
AC 720A	0252012-344-A	糸切り軸ブッシュ	Thread trimmer shaft busing	1	
" 721A	0252052-128-A	糸切りバネ	Thread trimmer spring	1	
" 795A	0252052-302-A	糸切りギヤ B (組)	Thread trimmer gear B ass'y	1	
SC 982	9015600-024	平小ネジ (1/4)	Screw (1/4)	1	
AC 794B	0252052-322-B	糸ユルメアーム	Operating arm	1	
" 793	0252052-331	カム接触指	Cam driving arm	1	
" 792	2120704-231	下軸カラー	Lower shaft collar	1	
SC 384	9501602-276	止メネジ (3/64)	Screw (3/16)	2	
SO 018	9060100-018	Oリング	"O" ring	1	
AC 791	0252052-343	糸切り軸	Thread trimmer shaft	1	
" 729	0252052-332	クッションラバー	Cushion rubber	1	
" 790	0252057-137	ソレノイドベース	Solenoid base	1	
" 789	0252052-114	クラッチレバー	Cluth lever	1	
" 788A	0252062-119-A	クラッチスプリング	Cluth spring	1	
SC 283	9015500-024	段ネジ (3/64)	Pivot screw (3/16)	1	
AC 797	0252057-125	ケーブル押エ	Cable retainer	1	
SC 085	9820406-467	ナベ小ネジ (M4 P=0.7)	Screw (M4 P = 0.7)	1	
AC 739C	0252047-131-C	糸切りソレノイド	Trimmer solenoid	1	
" 742	0252017-148	プラグピン	Plug pin	2	
" 741A	0252017-145-A	プラグキャップ (4P)	Plug cap (4P)	1	
" 743	0252017-144	プラグ (4P)	Plug (4P)	1	
" 787B	0252052-360-B	糸切りギヤ A (組)	Thread trimmer gear A ass'y	1	
SC 394	9625606-776	六角穴付キ止メネジ (M6 P=1.0)	Screw (M6 P = 1.0)	2	
NO.	変更内容 REVISION	互換性 INTERCHANGE.	機番 SERIAL NO.		

8. 返シ縫イ・糸払イ

Automatic Reverse Feed, Wiper

見出番号 REF. NO.	品番 PARTS NO.	品名	PARTS NAME	個数 QTY	備考 REMARK
		返シ縫イ	Automatic Reverse Feed		
AC 801	0252013-135	逆縫ニ又	Feed regulator fork	1	
SC 010	9013200-010	六角ボルト (1/8)	Screw (15/64)	1	
AC 803B	0252013-131-B	ソレノイドベース	Solenoid base	1	
" 804	0252023-132	バネ掛ケ	Spring retainer	1	
" 805	0252013-133	逆縫スプリング	Reverse spring	1	
SW 216	9120500-419	平座金	Washer	2	
" 323	9130500-308	バネ座金	Spring washer	3	
SN 040	9172500-104	ナット	Nut	1	
AC 808	0252035-233	ソレノイドカバー	Solenoid cover	1	
SC 085	9820406-467	ナベ小ネジ (M4 P=0.7)	Screw (M4 P = 0.7)	3	
AC 809A	0252027-133-A	返シ縫イソレノイド	Back tacking solenoid	1	
" 810A	0252013-105-A	逆縫駆動腕	Drive arm ass'y	1	
SW 099A	9030100-009-A	平座金	Washer	3	
" 322	9130300-108	バネ座金	Spring washer	3	
SC 086	9820408-467	ナベ小ネジ (M4 P=0.7)	Screw (M4 P = 0.7)	3	
AC 813	0252013-132	バネ掛ケ	Spacer	1	
SC 093	9820525-467	ナベ小ネジ (M5 P=0.8)	Screw (M5 P = 0.8)	1	
SW 323	9130500-308	バネ座金	Spring washer	1	
SN 040	9172500-104	ナット	Nut	1	
AC 815	0252013-137	ハンドホイールカバー	Cover	1	
SC 685	9541203-247	平小ネジ (3/8)	Screw (3/16)	3	
AC 816	0252035-225	スイッチホルダー	Microswitch case	1	
" 817A	0252015-131-A	ストッパー	Stopper	1	
SC 350	9501101-256	止メネジ (1/8)	Screw (11/64)	1	
AC 819A	0252015-101-A	押しボタン (組)	Finger bar for back tack ass'y	1	
SC 723	9240316-119	丸平小ネジ (M3 P=0.5)	Screw (M3 P = 0.5)	2	
AC 824	0252027-115-A	絶縁チューブ	Tube	1	
" 825	0252047-123	マイクロスイッチ	Microswitch	1	
" 826A	0252017-147-A	端子キャップ	Cap	2	
" 827	0252027-152	スイッチカバー	Cover plate	1	
" 891	0252037-125	ケーブル押エ	Cable retainer	3	
SC 086	9820408-467	ナベ小ネジ (M4 P=0.7)	Screw (M4 P = 0.7)	5	
AC 829	0252047-111	コード	Wire	1	
" 741	0252017-148	プラグピン	Plug pin	4	
" 740A	0252017-145-A	プラグキャップ (4P)	Plug cap (4P)	1	
" 830	0252027-144	プラグ (4P)	Plug (4P)		
NO.	変更内容 REVISION	互換性 INTERCHANGE.	機番 SERIAL NO.		

8. 返し縫イ・糸払イ

Automatic Reverse Feed, Wiper

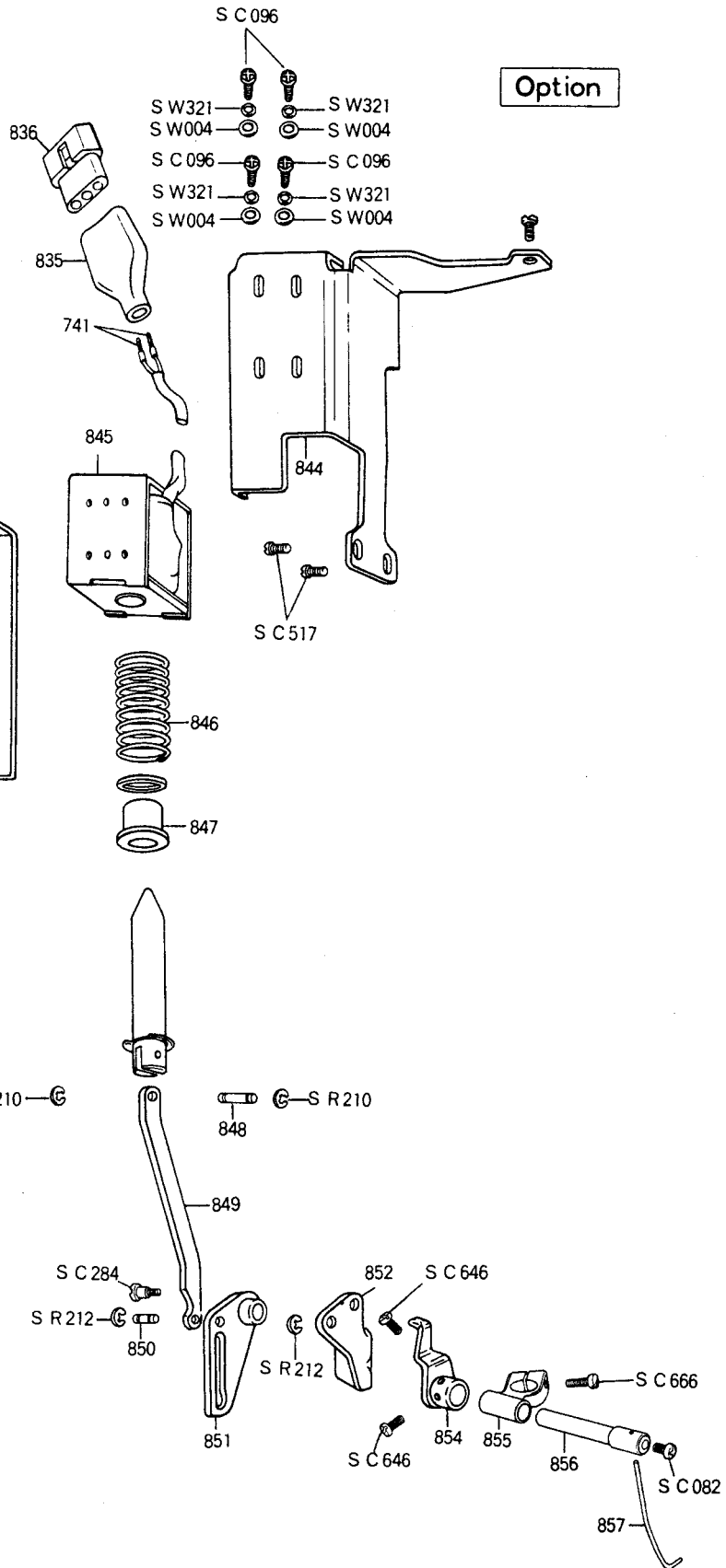
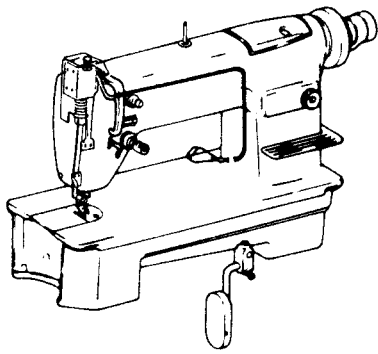

8. 返し縫イ・糸払イ

Automatic Reverse Feed, Wiper

見出番号 REF. NO.	品番 PARTS NO.	品名	PARTS NAME	個数 QTY	備考 REMARK
			Option Wiper		
AC 844	0252034-211	ワイパーベース	Solenoid mounting base	1	
SC 517	9531102-219	平小ネジ (1/4)	Screw (11/64)	2	
AC 845	0252127-131	ワイパーソレノイド	Wiper solenoid	1	
SW 004	9030100-004	平座金	Washer	4	
SW 321	9130200-108	バネ座金	Spring washer	4	
SC 096	9820308-467	ナベ小ネジ (M3 P=0.5)	Screw (M3 P=0.5)	4	
AC 741	0252017-148	プラグピン	Plug pin	2	
" 835	0252017-143	プラグキャップ (3P)	Plug cap (3P)	1	
" 836	0252017-142	プラグ (3P)	Plug (3P)	1	
" 846	0252014-238	ワイパースプリング	Wiper spring	1	
" 847	0252014-237	バネ受け	Spring support	1	
" 848	0252014-235	ソレノイドピン	Solenoid pin	1	
SR 210	9080200-010	E型止メ輪	Snap ring	2	
AC 849	0252014-234	ワイパーロッド	Connecting rod	1	
" 850	0252014-236	ロッドピン	Rod pin	1	
SR 212	9080200-012	E型止メ輪	Snap ring	2	
AC 851	0252014-230	ワイパーリンク	Wiper link	1	
" 852	0252014-233	ストッパー	Stopper	1	
SC 284	9015500-116	段ネジ (M4 P=0.7)	Pivot screw (M4 P=0.7)	1	
AC 853	0252014-228	ワイパーカバー	Base cover	1	
SC 668	9541103-102	丸平小ネジ (1/4)	Screw (11/64)	2	
AC 854	0252024-220	ワイパーアーム	Wiper arm	1	
SC 646	9540908-207	丸平小ネジ (1/4)	Screw (9/64)	2	
AC 855	0252024-222	ワイパー軸受	Wiper bushing	1	
SC 666	9541102-259	丸平小ネジ (1/4)	Screw (11/64)	1	
AC 856	0252024-223	ワイパー軸	Wiper shaft	1	
" 857	0252024-221	ワイパー	Wiper	1	
SC 082	9820306-467	ナベ小ネジ (M3 P=0.5)	Screw (M3 P=0.5)	1	
NO.	変更内容 REVISION	互換性 INTERCHANGE.	機番 SERIAL NO.		

9. 付属品関係

Accessories

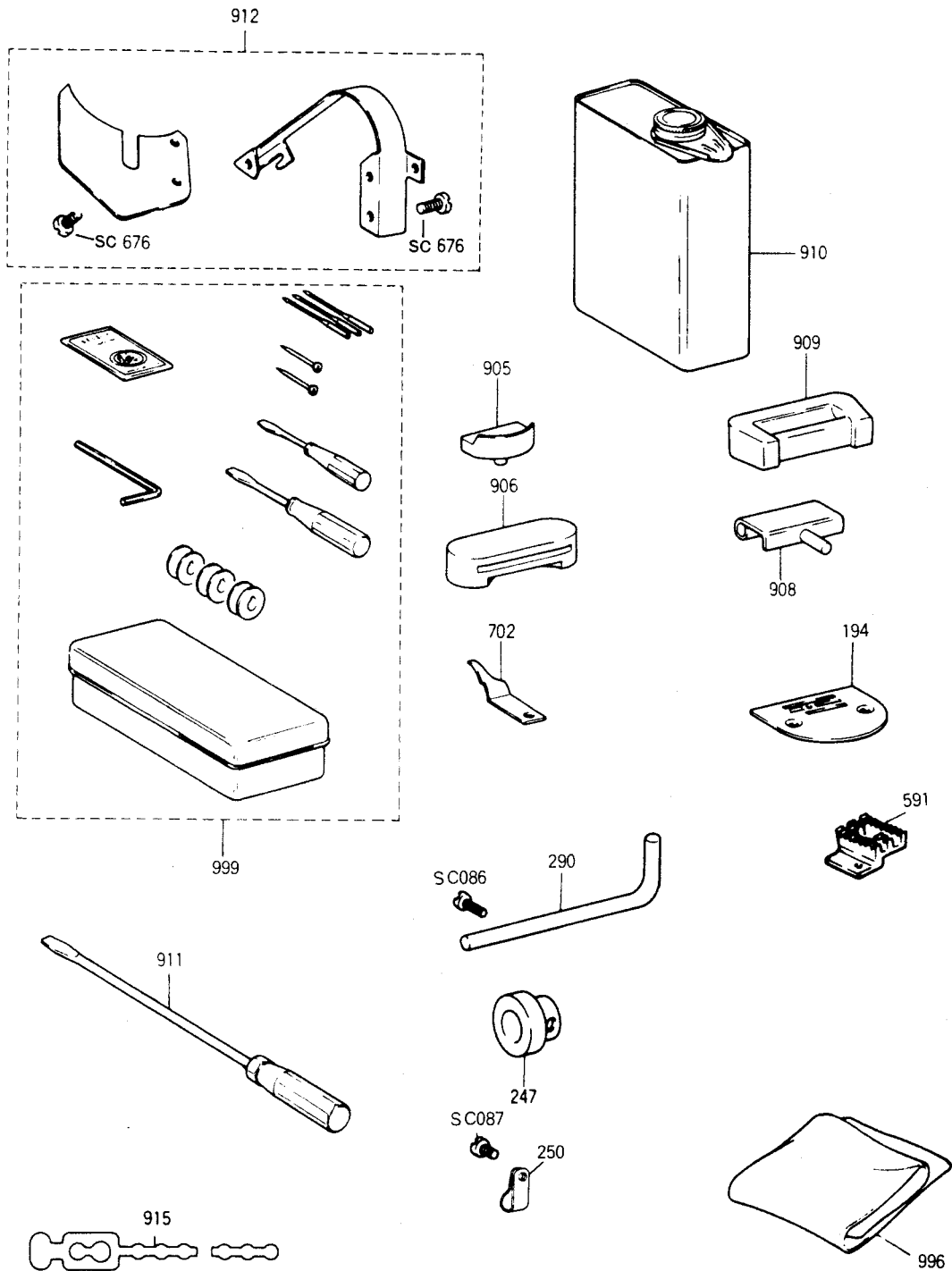

9. 付属品関係

Accessories

見出番号 REF. NO.	品番 PARTS NO.	品名	PARTS NAME	個数 QTY	備考 REMARK
AC 999B	0203091-110-B	付属品箱 (組)	Accessory box ass'y	1	
" 702B	0252052-141-B	ナイフ	Stationary knife	1	
" 905B	2111101-324-B	頭部支エゴム A	Corner rubber A	2	
" 906A	2111101-325-A	頭部支エゴム B	Corner rubber	2	
" 908A	0201385-173-A	ヒンジ	Hinge	2	
" 909B	0201385-174-B	ヒンジ座	Hinge rubber	2	
" 910	0201052-103	油 (油)	Oil	1	
" 911C	0201013-111-C	ドライバー特大	Driver LL	1	
" 912A	2110911-410-A	ベルトカバー (組)	Belt cover ass'y	1	
SC 676	9541109-107	丸平小ネジ (11/64)	Screw (11/64)	5	
AC 194A	2110343-112-A	針板 (4×1.4φ)	Needle plate (4 x 1.4)	1	
" 591A	2110225-223-A	送り歯 (4×1.15mm)	Feed dog (4 x 1.15mm)	1	
" 247A	0252058-113-A	センサーブッシュ	Connecting sleeve	1	
" 290	0252058-112	センサーグリップ	Senser grip	1	
SC 086	9820408-467	ナベ小ネジ (M4 P=0.7)	Screw (M4 P=0.7)	1	
AC 250	0252017-125	ナイロンクリップ	Nylon clip	1	
SC 087	9820412-467	ナベ小ネジ (M4 P=0.7)	Screw (M4 P=0.7)	1	
AC 915	0252027-126	ナイロンクランパー	Nylon crammer	1	
" 996A	0201076-111-A	頭部カバー	Machine head cover	1	
NO.	変更内容 REVISION		互換性 INTERCHANGE.	機番 SERIAL NO.	

サブクラス専用部品

Sub Class Special Parts

見出番号 REF. NO.	品番 PARTS NO.	品名	PARTS NAME	個数 QTY	A	G
AC 194A	2110343-112-A	針板 (4枚×1.4φ)	Needle plate (4 × 1.4φ)	1	○	
" 123C	2110803-113-C	針板 (3枚×2.6φ)	Needle plate (3 × 2.6φ)	1		○
" 193	2121612-350	糸調子 (組)	Thread tension unit	1		○
" 289C	2111122-111-C	針棒	Needle bar	1	○	
" 204D	2111102-111-D	針棒	Needle bar	1		○
" 288B	2210202-114-B	針棒メタル (下)	Needle bar bushing lower	1	○	
" 287	2110212-192	針 #9	Needle #9	1	○	
" 212	2120302-197	針 #21	Needle #21	1		○
" 286B	2111142-021-B	天ビン (組)	Thread take up lever ass'y	1	○	
" 285B	2111112-021-B	天ビン (組)	Thread taek up lever ass'y	1		○
" 284A	2121612-130-A	天ビークランク (組)	Take up lever crank ass'y	1		○
" 399	2111113-220	押エ (組)	Presser foot ass'y	1	○	
" 313A	2110923-220-A	押エ (組)	Presser foot ass'y	1		○
" 418A	2110904-310-A	大ガマ (組)	Rotary hook ass'y	1		○
" 592	2111115-205	クランクロッド腕 (組)	Feed lifting bell crank ass'y	1		○
" 591A	2110225-223-A	送り歯	Feed dog	1	○	
" 553A	2110905-223-A	送り歯	Feed dog	1		○
" 555B	2110315-350-B	送りダイヤル (組)	Feed regulator dial ass'y	1		○
NO.	変更内容 REVISION		互換性 INTERCHANGE.	機番 SERIAL NO.		

Automatic Presser Foot Lifter

目 次

CONTENTS

	頁
	Page
1. Automatic Presser Foot Lifter.....	32
(Electro Magnetic Type)	
2. Automatic Presser Foot Lifter.....	34
(Pneumatic Air Type)	

1. Automatic Presser Foot Lifter (Electro Magnetic Type)

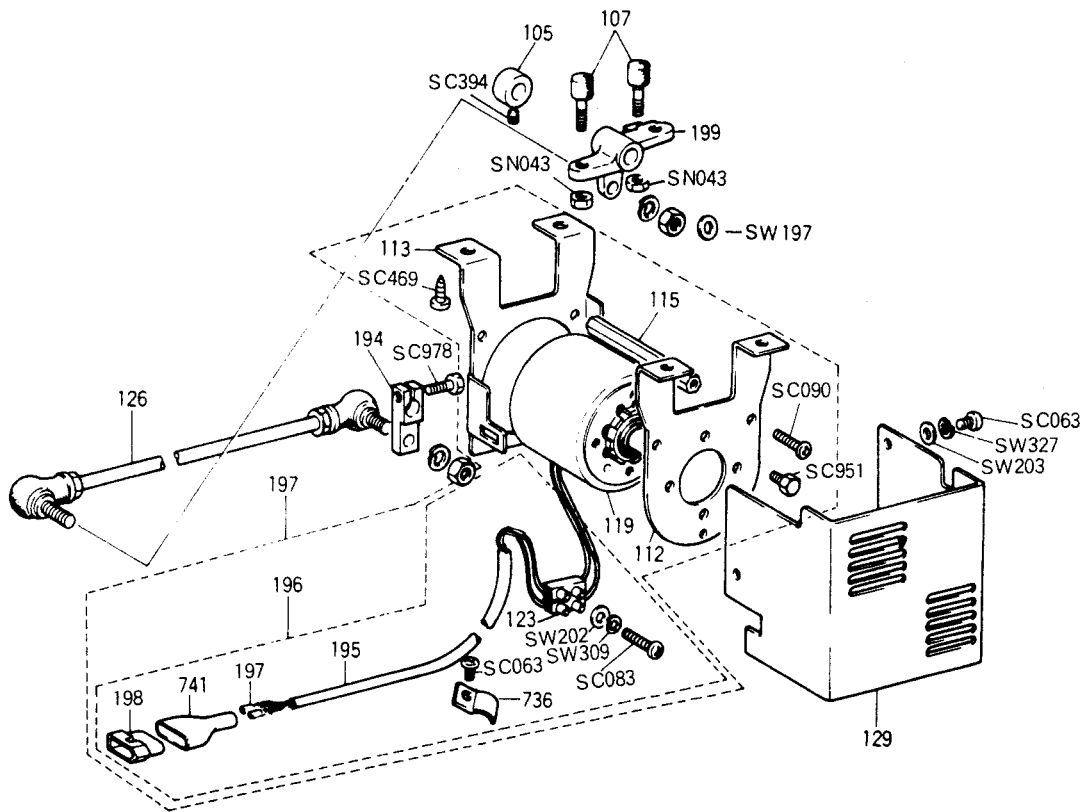

1. Automatic Presser Foot Lifter (Electro Magnetic Type)

見出番号 REF. NO.	品番 PARTS NO.	品名	PARTS NAME	個数 QTY	備考 REMARK
SW 197	9030100-197	平座金	Washer	1	
AX 105	0252014-122	カラー	Collar	1	
SC 394	9625606-776	六角穴つき止メネジ(M6P=1.0)	Screw (M6 P=1.0)	1	
AX 199	0252024-131	押エ上ゲ腕	Presser bar lifter arm	1	
" 107	0252014-137	膝上ゲストッパー	Knee lifter stopper	2	
SN 043	9172600-119	ナット	Nut	2	
SC 469	9322932-319	プラスチックネジ	Wood screw	4	
AX 197A	0252024-140-A	押エ上ゲソレノイド(組)	Presser lifting solenoid ass'y	1	
" 112A	0252014-141-A	ソレノイド取付板(A)	Solenoid installing bracket (A)	1	
" 113A	0252014-151-A	ソレノイド取付板(B)	Solenoid installing bracket (B)	1	
SC 090	9820512-467	ナベ小ネジ(M5P=0.8)	Screw (M5 P=0.8)	6	
AX 115A	0252024-136-A	スペーサー	Spacer	3	
" 195	0252047-110	コード(組)	Wire ass'y	1	
" 194	0252097-111	キャブタイヤケーブル	Cabtyre cable	1	
198	0252037-144	プラグ4P	Plug 4P	1	
" 741A	0252017-145-A	プラグキャップ4P	Plug cap 4P	1	
AX 197	0252027-148	プラグピン	Plug pin	2	
AX 119	0252037-133	押エ上ゲソレノイド	Presser lifting solenoid	1	
SW 202	9110200-107	平座金	Washer	1	
SW 309	9130200-108	バネ座金	Spring washer	1	
SC 083	9820314-467	ナベ小ネジ(M3P=0.5)	Screw (M3 P=0.5)	1	
AX 123	0252017-121	端子台	Terminal base	1	
AC 736	0252037-125	ケーブル押エ	Cable retainer	1	
SC 063	9225508-418	ナベ小ネジ(M4P=0.7)	Screw (M4 P=0.7)	1	
SC 951	9711608-119	六角ボルト(1/4)	Screw (1/4)	4	
AX 126E	0252014-104-E	ロッド(組)	Rod ass'y	1	
SC 978	9711620-119	六角ボルト(M6P=1.0)	Screw (M6 P=1.0)	1	
AX 196	0252024-132	駆動腕	Drive arm	1	
" 129	0252014-142	ソレノイドカバー	Solenoid cover	1	
SW 327	9140300-318	バネ座金	Spring washer	3	
SW 203	9110300-419	平座金	Washer	3	
SC 063	9225508-418	ナベ小ネジ(M4P=0.7)	Screw (M4 P=0.7)	3	
NO.	変更内容 REVISION		互換性 INTERCHANGE.	機番 SERIAL NO.	



2. Automatic Presser Foot Lifter (Pneumatic Air Type)

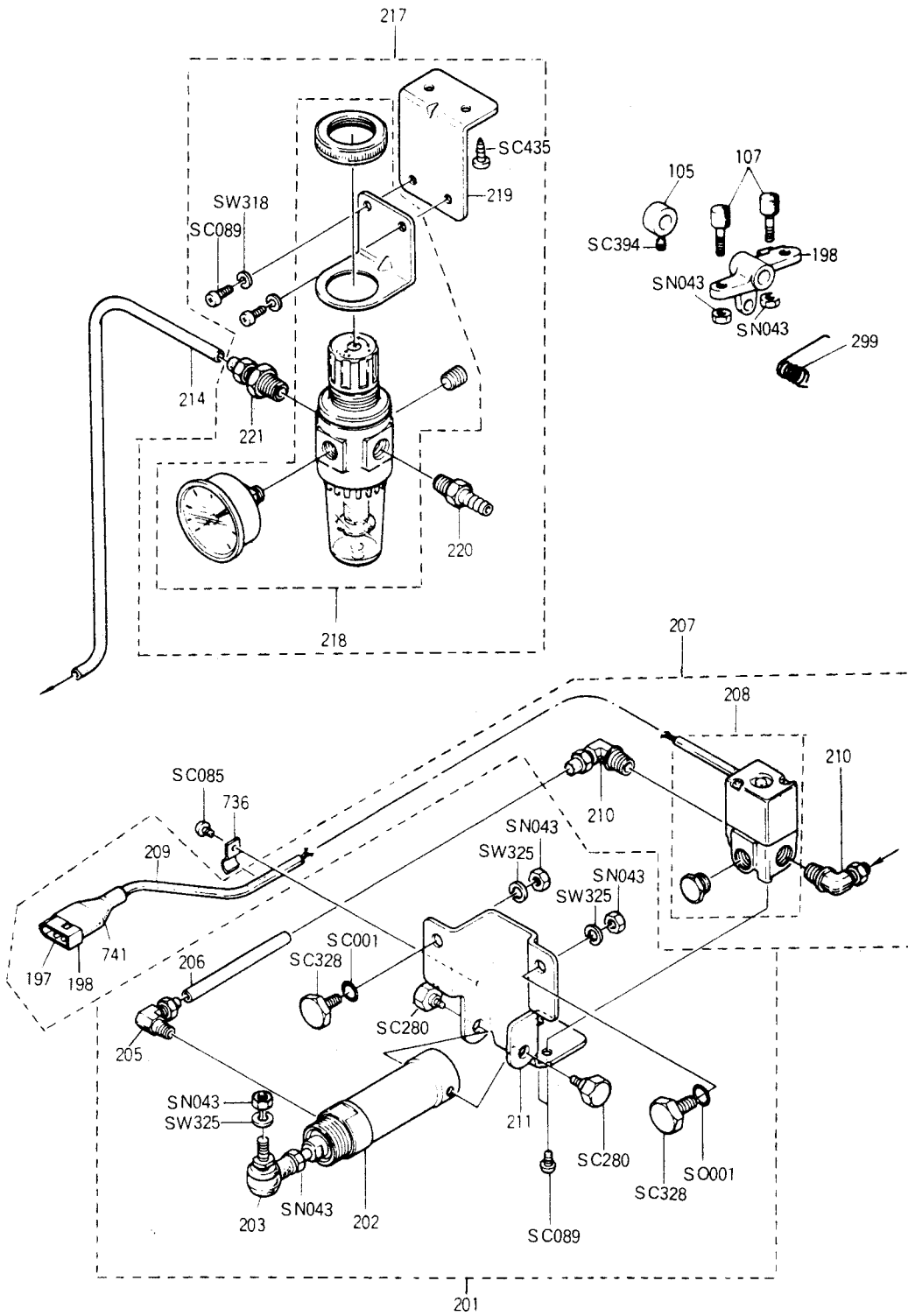

2. Automatic Presser Foot Lifter (Pneumatic Air Type)

見出番号 REF. NO.	品番 PARTS NO.	品名	PARTS NAME	個数 QTY	備考 REMARK
AX 201A	0252016-130-A	エアシリンダー (組)	Air cylinder ass'y	1	
" 202	0252016-131	エアシリンダー	Air cylinder	1	
" 203	0211021-168	ボールジョイント	Ball joint	1	
SW 325	9130600-108	バネ座金	Spring washer	1	
SN 043	9172600-119	ナット	Nut	2	
" 205	0252026-144	エルボ (1/8)	Elbow (1/8)	1	
" 206	0252016-151	エアチューブ	Air tube	1	
" 207	0252016-160	ソレノイドバルブ (組)	Solenoid valve ass'y	1	
" 208	0252016-161	ソレノイドバルブ	Solenoid valve	1	
" 209	0252017-167	絶縁チューブ	Tube	1	
AX 197	0252027-148	プラグピン	Plug pin	2	
AC 741A	0252017-145-A	プラグキャップ 4 P	Plug cap (4P)	1	
AX 198	0252037-144	プラグ 4 P	Plug (4P)	1	
AX 210	0254016-146	エルボ (1/4)	Elbow (1/4)	2	
" 211A	0252014-111-A	ブラケット	Bracket	1	
SC 280	9018500-032	段ネジ	Pivot screw	2	
SC 089	9820508-467	ナベ小ネジ (M5 P=0.8)	Screw (M5 P=0.8)	2	
AC 736	0252037-125	ケーブル押エ	Cable retainer	1	
SC 085	9820406-467	ナベ小ネジ (M4 P=0.7)	Screw (M4 P=0.7)	1	
AX 214A	0252026-151-A	エアチューブ	Air tube	1	
SC 328	9025900-032	六角ボルト	Screw	2	
SO 001	9060100-001	Oリング	Rubber packing	2	
SW 325	9130600-108	バネ座金	Spring washer	2	
SN 043	9172600-119	ナット	Nut	2	
AC 217	0252016-102	フィルターレギュレーター (組)	Filter regulator ass'y	1	
" 218	0252016-117	フィルターレギュレーター	Filter regulator	1	
" 219	0252016-118	レギュレーターブラケット	Regulator Bracket	1	
" 220	0252026-145	ホースニップル (1/4)	Horse nipple (1/4)	1	
" 221	0252016-153	コネクター (1/4)	Connector (1/4)	1	
SW 318	9130500-318	バネ座金	Spring washer	2	
SC 089	9820508-467	ナベ小ネジ (M5 P=0.8)	Screw (M5 P=0.8)	2	
SC 435	9312820-119	プラスチックネジ	Wood screw	2	
AX 105	0252014-122	カラー	Collar	1	
SC 394	9625606-776	六角穴つき止メネジ (M6 P=1.0)	Screw (M6 P=1.0)	1	
AX 198	0252024-131	押エ上ゲ腕	Presser bar lifter arm	1	
" 107	0252014-137	膝上ゲストッパー	Knee lifter stopper	2	
SN 043	9172600-119	ナット	Nut	2	
AX 299	0252024-125	押エ上ゲ軸バネ	Knee lifter shaft spring	1	
NO.	変更内容 REVISION		互換性 INTERCHANGE.	機番 SERIAL NO.	

2

