

SINGER
134W7,W8

LIST OF PARTS



MACHINES Nos. 134w7 and 134w8

INDEX

	Page
Accessories	17
Robbin Winder	17
Driving Equipment	20
Idler	19-23
Machine No. 134w7	5
" " 134w8	15
Miscellaneous Parts	28
Numerical List of Parts	29
Power Table Accessories	19
Stands	24
Starting and Foot Lifter Treadle	19-20
Tables	28
Thread Unwinder	18
Under Driver	20

INSTRUCTIONS FOR ORDERING

In ordering from this list, use ONLY the PART number in the FIRST column.

The number stamped on a Sewing Machine Part is the number of the Single Part only, except when the part includes Set Screws, Clamping Screws, Studs and Rollers Spun on, Small Wires riveted, or Parts soldered together, etc., which it is necessary to furnish in combination.

Every combination of parts sent out has its specific number which, although not stamped on Parts (except in above case), must be used when ordering the combination.

Each number always indicates the SAME PART in whatever list it appears, or for whatever Machine.

The letters after some of the numbers indicate the style of finish only, as follows:

- A. Hardened, Polished, Nickel Plated and Buffed.
- B. Polished, Nickel Plated and Buffed.
- C. Hardened only.
- D. Polished only.
- E. Soft, not polished.
- F. Hardened and Polished.
- H. Blued.
- J. Nickel Plated only.
- R. Merlized.
- X. Black Oxide.
- XC. Hardened and Black Oxide.
- Y. Blade Nickel only.

These letters MUST BE USED when they appear in the list and AFTER the number, as in the list.

In this series

200001 to 201500 and 350001 to 351500 are Screw Numbers.
 201501 to 201800 and 351501 to 351800 are Nut Numbers.
 201801 to 202000 and 351801 to 352000 are Roller Numbers.
 202001 to 350000 are Numbers of Machine Parts.

The figures in the second column refer only to the plate in which the illustration of the part is shown and are TO BE USED in ordering.

Two or more numbers over a cut indicate that the difference between such parts is not visible in an illustration.

Parts marked with an asterisk (*) are furnished when repairs are made at the factory.

LIST OF PARTS COMPLETE FOR

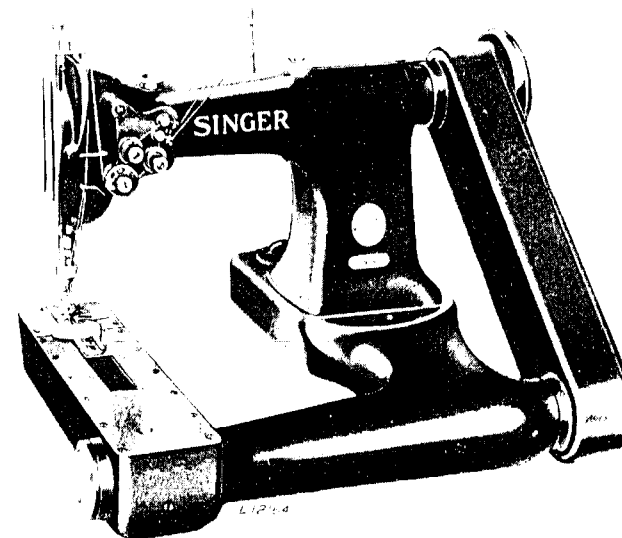

MACHINE No. 134w7

FEED OFF THE ARM MACHINE.

TWO NEEDLES. DROP FEED. CYLINDER BED.

For Lap Seam Felling Shirts, Pajamas, Etc.

In Gauges from 3/32 to 1/4 inch.

No.	Plate	Name
*249301	-----	Arm with 200368H, 202135 and 234047
202247	15861	" Cap
200278H	15861	" " Screw
202248	15861	" " " Washer
200502B	15861	" Oil Thumb Screw
8582	15870	" Position Pin (2)
200010E	15870	" Screw (3)
202005	15870	" " Washer (3)
249463	15861	" Shaft with 200357E and 350332E
249440	15861	" " Ball Bearing
*249441	15861	" " " " (back) Collar with two 200378C
249442	15861	Arm Shaft Ball Bearing (back) Collar 249441 with 249440

PARTS FOR MACHINE No. 134w7

No.	Plate	Name
200378C	15861	Arm Shaft Ball Bearing (back) Collar Set Screw
*249443	-----	Arm Shaft Ball Bearing (back) Retaining Washer
*249444	-----	Arm Shaft Ball Bearing (back) Sleeve
249308	15861	" " " " " " Gasket
200335C	15861	" " " " " " Set Screw
*249445	15861	Arm Shaft Ball Bearing (front) Collar with two 200378C
249446	15861	Arm Shaft Ball Bearing (front) Collar 249445 with 249440
200378C	15861	Arm Shaft Ball Bearing (front) Collar Set Screw
*249447	-----	Arm Shaft Ball Bearing (front) Sleeve
200374C	15861	" " " " " " Set Screw
249311	15845	Arm Shaft Connection Belt
249312	15845	" " " " Guard with two 200383C
249313	15845	Arm Shaft Connection Belt Guard Cover
201260B	15845	" " " " " " Screw (2)
200383C	15845	Arm Shaft Connection Belt Guard Set Screw
249314	15861	Arm Shaft Connection Belt Pulley with two each 201254C and 202253
201254C	15861	Arm Shaft Connection Belt Pulley Set Screw
202253	15861	Arm Shaft Connection Belt Pulley Spring Flange
350332E	15861	Arm Shaft Oil Reservoir Screw
200357E	15861	" " " " Stop Screw
249481	15861	Balance Wheel (disc) (belt groove 2-1/8 in.diam.) with 200328C and 200335C
350419H	15861	Balance Wheel Adjusting Screw
200328C	15861	" " " " Position Screw
200335C	15861	" " " " Set Screw
*264760	-----	Bed with 200357E
249319	15870	" Cover Plate (end)
249320	15870	" " " " Gasket
2005707C	15970	" " " " Screw (3)
249465	15844	" " " " (top)
249466	15844	" " " " Gasket
200578XC	15844	" " " " Screw (13)
249323	15870	" Oil Cover
50608R	15833	" " Drain Hole Plug Screw
139017	15833	" " " " " " Washer (leather)
249467	15846	Bed Oil Retaining Felt

PARTS FOR MACHINE No. 134w7

No.	Plate	Name
249468	15846	Bed Oil Retaining Felt Clamp Plate
201020E	15846	" " " " " " Screw
201537E	15846	" " " " " " Nut
249469	15846	" " " " " Support Plate
249470	15846	" " " " " " 249469 with 249467, 249468, two each 201020E and 201537E
200357E	15833	Bed Oil Stop Screw
249326	15833	" Shaft
249440	15833	" " Ball Bearing
264757	15833	" " " " (center)
*264758	15833	" " " " " Collar with two 200382C
264759	15833	Bed Shaft Ball Bearing (center) Collar 264758 with 264757
200382C	15833	Bed Shaft Ball Bearing (center) Collar Set Screw
*249448	15833	Bed Shaft Ball Bearing (left) Collar with two 200378C
249449	15833	Bed Shaft Ball Bearing (left) Collar 249448 with 249440
200378C	15833	Bed Shaft Ball Bearing (left) Collar Set Screw
*249447	-----	Bed Shaft Ball Bearing (left) Sleeve
*249441	15833	" " " " (right) Collar with two 200378C
249442	15833	Bed Shaft Ball Bearing (right) Collar 249441 with 249440
200378C	15833	Bed Shaft Ball Bearing (right) Collar Set Screw
*249443	-----	Bed Shaft Ball Bearing (right) Retaining Washer
*249450	-----	Bed Shaft Ball Bearing (right) Sleeve
249308	15833	" " " " " " Gasket
200347C	15833	" " " " " " Set Screw
249330	15833	Bed Shaft Connection Belt Pulley with 202253 and two 201254C
201254C	15833	Bed Shaft Connection Belt Pulley Set Screw
202253	15833	Bed Shaft Connection Belt Pulley Spring Flange
203470	15863	Bobbin
*249331	-----	" Case (left)
*249332	-----	" " (right)
203648	15863	" " Latch
*202056	-----	" " " Pin
203473	15863	" " " Plunger
203474	15863	" " " Spring
249482	15865	" " Opener

No.	Plate	Name
249334	15865	Bobbin Case Opener Driving Eccentric with two 200386C
249335	15865	Bobbin Case Opener Driving Eccentric Fork
200101D	15865	Bobbin Case Opener Driving Eccentric Fork Cap Screw
200386C	15865	Bobbin Case Opener Driving Eccentric Set Screw
249486	15865	Bobbin Case Opener Link
200989D	15865	" " " " Cap Screw
249337	15865	" " " " Hinge Stud
200364C	15865	" " " " " " " " Set Screw
249487	15865	Bobbin Case Opener Link Oil Guard
350238D	15865	" " " " " " " " Screw
200190D	15865	" " " " " " " " Screw
202603	15865	" " " " " " " " Washer
203214	15863	" " " " " " " " Tension Spring
200984C	15863	" " " " " " " " Regulating Screw
200594C	15863	" " " " " " " " Screw
203216	15863	" " " " " " " " Washer (cloth)
249339	15863	Bobbin Case (left) complete, Nos. 200594C, 200984C, 202056, 203214, 203216, 203473, 203474, 203648 and 249331
249340	15864	Bobbin Case (right) complete, Nos. 200594C, 200984C, 202056, 203214, 203216, 203473, 203474, 203648 and 249332
202274	15870	Face Plate
202135	15870	" " " " Position Pin
200462B	15870	" " " " Thumb Screw
249406	15871	Feed Dog, for 249424
249407	15872	" " " " 249425
249408	15871	" " " " 249426
200106E	15871	" " " " Screw (2)
200122H	15840	" " " " Support Screw
249341	15833	" " " " Driving Eccentric (adjustable)
249342	15833	" " " " Adjusting Disc
249343	15833	" " " " " " " " Clamp Plate
249344	15833	Feed Driving Eccentric Adjusting Disc Friction Spring (2)
200085C	15833	Feed Driving Eccentric Adjusting Disc Friction Spring Screw (2)
201188C	15833	Feed Driving Eccentric Adjusting Disc Friction Spring Screw Set Screw (2)
249345	15833	Feed Driving Eccentric Adjusting Disc Friction Spring Screw Set Screw Packing (brass) (2)
249346	15833	Feed Driving Eccentric Driving Stud
249347	15833	" " " " " " " " Slide Block

Block

No.	Plate	Name
*249348	-----	Feed Driving Eccentric Flange with 249346
249349	15833	Feed Driving Eccentric Flange Pin
249350	15840	" " " " Fork
200019E	15840	" " " " " " Screw (2)
202622	15840	" " " " " " Washer (2)
249351	15840	" " " " " " Slide Block (two pieces)
249352	15833	" " " " " " Lifting Eccentric with 200373C and 200380C
200373C	15833	Feed Lifting Eccentric Position Screw
200380C	15833	" " " " " " Set Screw
249353	15840	" " " " " " Fork Lever with 200122H
249471	15840	" " " " " " Bracket with 200351C
202135	15840	" " " " " " " " Position Pin (2)
200084F	15840	Feed Lifting Fork Lever Bracket Screw (2)
249355	15840	Feed Lifting Fork Lever Hinge Block
249356	15840	" " " " " " " " Stud (eccentric)
200351C	15840	Feed Lifting Fork Lever Hinge Stud Set Screw
249357	15840	Feed Lifting Fork Lever Slide Block (two pieces)
350354A	15844	Feed Regulating Screw Stud
201524E	15844	" " " " " " Nut
249457	15844	" " " " " " Washer (paper)
249458	15844	" " " " " " " " (steel)
249360	15870	Foot Lifter Lifting Lever
200242H	15870	" " " " " " " " Hinge Screw
233390	15870	" " " " " " " " Washer
227561	15870	" " " " " " " " Spring
200835D	15870	" " " " " " " " Screw
*249361	-----	Hook (sewing)
249362	15863	" 249361 with 240201, 249384, 249390, two each 201253F and 201334H
249363	15863	Hook and Bobbin Case (left) complete, Nos. 249339 and 249362
249364	15864	Hook and Bobbin Case (right) complete, Nos. 249340 and 249362
249365	15865	Hook Ball Bearing (4)
249366	15865	" " " " " " Sleeve (2)
249367	15865	" " " " " " 249366 with 249488 and two 249365
200446C	15865	Hook Ball Bearing Sleeve Position Screw
200387C	15865	" " " " " " " " " " " " Check Screw
249488	15865	Hook Ball Bearing Spacing Washer
249483	15865	" Bevel Gear Shaft
350335C	15865	" " " " " " " " Screw

No.	Plate	Name
249477	15844	Hook Cover Plate (left), for gauges from 3/32 to 1/4 in., in steps of 1/32 in. (state gauge required)
249477	15844	Hook Cover Plate (right), for gauges from 3/32 to 1/4 in., in steps of 1/32 in. (state gauge required)
200571XC	15844	Hook Cover Plate Hinge Screw (2)
200389C	15844	" " " " " Set Screw (2)
248441	15844	" " " " " " Pack- ing (brass) (2)
249371	15865	Hook Driving Gear Shaft
249380	15865	" " " " Bushing
200032E	15865	" " " " " Pinch Screw
249377	15839	" " Shaft (front) (2)
249474	15839	" " " " Bearing (2)
201094C	15839	" " " " " Screw (4)
249375	15839	" " " " Bushing (bronze) (2)
249489	15839	Hook Driving Shaft (intermediate) (2)
249377	15839	" " " " Connection with two 200394C (4)
200394C	15839	Hook Driving Shaft (intermediate) Con- nection Set Screw
*249436	-----	Hook Driving Shaft Driving Bevel Gear (left) with 200383C and 200398C
249437	15833	Hook Driving Shaft Driving Bevel Gear 249476 with 249348 and three 249349
200398C	15833	Hook Driving Shaft Driving Bevel Gear (left) Position Screw
200383C	15833	Hook Driving Shaft Driving Bevel Gear (left) Set Screw
249433	15833	Hook Driving Shaft Driving Bevel Gear (right) with 200362C and 200439C
200439C	15833	Hook Driving Shaft Driving Bevel Gear (right) Position Screw
200363C	15833	Hook Driving Shaft Driving Bevel Gear (right) Set Screw
249439	15839	Hook Driving Shaft Driving Bevel Pinion with two 200112C (2)
200112C	15839	Hook Driving Shaft Driving Bevel Pinion Set Screw
249384	15863	Hook Gib
201253F	15863	" " Screw
240201	15863	" Oiling Felt
249475	15865	" Saddle (left) with 200364C and two 200032E
249476	15866	Hook Saddle (right) with 200364C and two 200032E

No.	Plate	Name
200226E	15865	Hook Saddle Hinge Screw (2)
249477	15865	" " Oil Strainer
201143H	15865	" " " " Screw
200032E	15865	" " Screw (2)
203357	15865	" " " Washer (2)
249484	15865	Hook Saddle (left) complete, Nos. 200101D, 200190D, 200387C, 200446C, 200989D, 202603, 249334, 249335, 249337, 249363, 249367, 249371, 249475, 249477, 249482, 249483, 249486, 249487, 350238D, 350335C, two each 201143H and 249380
249485	15866	Hook Saddle (right) complete, Nos. 200101D 200190D, 200387C, 200446C, 200989D, 202603, 249334, 249335, 249337, 249364, 249367, 249371, 249476, 249477, 249482, 249483, 249486, 249487, 350238D, 350335C, two each 201143H and 249380
249390	15865	Hook Washer
201334H	15863	" " Screw
249480	15870	Lap Seam Feller Base Plate
230998	15870	" " " Curl (lower) with 230734, for F, L, M, MH or H material
200175D	15870	Lap Seam Feller Curl (lower) Spring Screw
230734	15870	Lap Seam Feller Curl (lower) Spring (light) (right hand)
230999	15870	Lap Seam Feller Curl (upper), for F, L, M, MH or H material
200170B	15870	Lap Seam Feller Screw (2)
231000	15870	" " " Shank, for F, L, M, MH or H material
230048	15870	Lap Seam Feller on Shank complete (right hand), for general work, for 3/32 to 1/4 in. gauge machines, for F, L, M, MH or H material, Nos. 230998 to 231000 and two 200175D
249391	15867	Needle Bar and Holder, in gauges from 3/32 to 1/4 in., in steps of 1/32 in. with two 200141F
235027	15867	Needle Bar Bushing
200352C	15867	" " " Set Screw
202552	15867	" " Connecting Link
264718	15867	" " " " Oil Guard
200161D	15867	" " " " " Screw
249393	15867	" " " " Stud with 202254
202254	15867	Needle Bar Connecting Link Stud Oil Pack- ing (wick)
200374C	15867	Needle Bar Connecting Link Stud Set Screw

No.	Plate	Name
200383C	15867	Needle Bar Connecting Link Stud Set Screw
249394	15867	Needle Bar Connecting Stud with 200086C and 202330
202330	15867	Needle Bar Connecting Stud Oil Packing (wick)
200086C	15867	Needle Bar Connecting Stud Pinch Screw
249395	15867	" " Crank with 200335C, 200374C, 200383C, 200428C and 249393
249396	15867	Needle Bar Crank Friction Washer
200428C	15867	" " " Position Screw
200335C	15867	" " " Set Screw
249397	15867	" " Support
202244	15867	" " " Oil Packing (wick)
200352C	15867	" " " Set Screw
200141F	15867	" Set Screw
244033	15868	Presser Bar (hollow)
202335	15868	" " 244033 with 200074F
207072	15868	" " Bushing
200352C	15868	" " " Set Screw
202339	15868	" " Lifter
200653C	15868	" " " Hinge Screw
244004	15868	" " Lifting Releasing Lever Bracket
200260D	15868	Presser Bar Lifting Releasing Lever Bracket Guide Screw
206608	15868	Presser Bar Lifting Releasing Lever Bracket Spring
235901	15868	Presser Bar Position Guide with 200054E
200054E	15868	" " " " Pinch Screw
263098	15868	" " Spring
234044	15868	" " " Stop Rod
200492B	15868	" " Thumb Screw (pressure regulating)
200475B	15868	Presser Bar Thumb Screw Thumb Set Screw
202355	15868	" " " " " " " " Packing (brass)
230795	15872	Presser Foot Hinge Pin
229193	15872	" " Plate
229195	15872	" " "
200074F	15868	" " Screw
202923	15872	" " Shank
229194	15872	Presser Foot (hinged) complete, 46 needle hole, in gauges 3/32, 1/8, 5/32 and 3/16 in., Nos. 202923, 229193 and 230795, for felling
229167	15872	Presser Foot (hinged) complete, 46 needle hole, in gauges 7/32 and 1/4 in., Nos. 202923, 229195 and 230795
247570	15867	Take-up Lever

No.	Plate	Name
249398	15867	Take-up Lever Driving Stud with 202277
202277	15867	" " " " Oil Packing (wick)
202400	15867	Take-up Lever Hinge Stud with 202423
202423	15867	" " " " Oil Packing (wick)
200383C	15867	Take-up Lever Hinge Stud Set Screw
202401	15868	" " Oiling Felt
200132E	15868	" " " " Screw
249399	15868	" " " Wick with 249400
200081E	15868	" " " " Clamp Screw
201537E	15868	" " " " " Nut
*249400	-----	" " " " Wire
234086	15869	Tension Bracket with two each 200397H, 201224B and 236060
200159F	15869	Tension Bracket Screw
234047	15869	" " " Socket
200368H	15869	" " " " Set Screw
236098	15869	" " Thread Guide (double)
200174H	15869	" " " " Screw
234087	15869	Tension Bracket complete, Nos. 200174H, 200978H, 201199F, 223703, 223706, 234086, 236098, 237174, two each 13710, 200309E, 204059, 204271, 223704, three 201572B and four 244048
244048	15869	Tension Disc
236060	15869	" " Position Pin
223703	15869	" Release Lever
235072	15868	" " " Rod
200309E	15869	" " " Screw
223704	15869	" " Plunger
204271	15869	" " Washer
13710	15869	" Spring
201224B	15869	" Stud
201572B	15869	" Thumb Nut
223706	15869	Thread Controller Disc
200978H	15869	" " " Screw
237174	15869	" " Spring
242117	15869	" " " Stop
200132E	15869	" " " " Screw
201199F	15869	" " Stud with 204925
200061C	15869	" " " Set Screw
201572B	15869	" " " Thumb Nut
204925	15869	" " " Washer
249401	15840	" Cutter Blade
249402	15840	" " " Clamp Plate
201279H	15840	" " " " " Screw (2)
249403	15840	" " Block
200567H	15840	" " " Screw (2)
202414	15869	" Guide

No.	Plate	Name
202415	15869	Thread Guide
202417	15869	" "
224028	15861	" "
200582H	15869	" " Screw
200355H	15869	" " Set Screw
200397H	15869	" " " "
202091	15869	" Retainer Sleeve
202092	15869	" " Spring
204058	15869	" " Stud
200397H	15869	" " " Set Screw
204059	15869	Thread Retainer complete, Nos. 202091, 202092 and 204058
249424	15871	Throat Plate, 50 needle hole, for needle sizes 14 and 15, in gauges 1/8 and 5/32 in., for 249406
249425	15872	Throat Plate, 50 needle hole, for needle sizes 14 and 15, in gauges 3/16, 7/32 and 1/4 in., for 249407
249426	15871	Throat Plate, 50 needle hole, for needle sizes 14 and 15, in 3/32 in. gauge, for 249408
249404	15871	Throat Plate Clamp Plate
200161D	15871	" " " " Screw
203376	15871	" " Position Pin
691F	15871	" " Screw

Genuine Singer Needles should be used
in Singer Machines.
These Needles and their Containers
are marked with the
Company's Trade Mark "SIMANCO." 1

Needles in Containers marked
"For Singer Machines"
are not Singer made needles. 2

MACHINE No. 134w8

For Closing or Stripping Elastic Corsets and Ladies' Foundation
Garments also for Lap Seam Felling on Ladies' Silk,
Satin and Rayon Underwear.

In Gauges from 3/32 to 1 1/4 inches.

SAME AS MACHINE NO. 134w7 WITH THE

FOLLOWING EXCEPTIONS:

No.	Plate	Name
*264801	-----	Bed with 200357E, in place of 264760
264802	15845	" Cover Plate (top), in place of 249465
264803	15845	" " " " Gasket, in place of 249466
50608R	15833	Bed Oil Drain Hole Plug Screw, not used
139017	15833	" " " " " " Washer (leather), not used
264804	15882	Bed Oil Retaining Felt, in place of 249467
264812	15882	Bed Oil Retaining Felt
264805	15882	" " " " Clamp Plate, in place of 249468
264813	15882	Bed Oil Retaining Felt Clamp Plate
264806	15882	" " " " Support Plate, in place of 249469
264814	15882	Bed Oil Retaining Felt Support Plate
264807	15882	" " " " " " " 264806 with 264804, 264805, two each 201020E and 201537E, for gauges from 21/32 to 1-1/4 in., in place of 249470
264815	15882	Bed Oil Retaining Felt Support Plate 264814 with 264812, 264813, two each 201020E and 201537E, for gauges from 3/32 to 5/8 inch
264759	15833	Bed Shaft Ball Bearing (center) Collar 264758 with 264757, not used
211298	15871	Feed Dog, for 249426, in place of 249408
264901	15871	" " " 249424, in place of 249406
264902	15872	" " " 249425, in place of 249407
264808	15844	Hook Cover Plate (left), for gauges from 3/32 to 1/4 in. in steps of 1/32 in. (state gauge required), in place of 249472
264810	15844	Hook Cover Plate (left), for gauges from 9/32 to 1-1/4 in., in steps of 1/32 in. (state gauge required)

No.	Plate	Name
264809	15844	Hook Cover Plate (right), for gauges from 3/32 to 1/4 in., in steps of 1/32 in. (state gauge required) in place of 249473
264811	15844	Hook Cover Plate (right), for gauges from 9/32 to 1-1/4 in., in steps of 1/32 in. (state gauge required)
249480	15870	Lap Seam Feller Base Plate, not used
230048	15870	Lap Seam Feller on Shank complete (right hand), for 1/16 to 1 in. gauge machines for general work, for F, L, MH or H material, Nos. 230998 to 231000 and two 200175B, not used
200170B	15870	Lap Seam Feller Screw (2), not used
249391	15867	Needle Bar and Holder in gauges 3/32 to 5/8 in., in steps of 1/32 in. with two 200141F
229167	15872	Presser Foot (hinged) complete, 46 needle hole, in gauges 7/32, 1/4, 9/32 and 5/16 in., Nos. 202923, 229195 and 230795

Genuine Singer Needles should be used
in Singer Machines.
These Needles and their Containers
are marked with the
Company's Trade Mark "SIMANCO." 1

Needles in Containers marked
"For Singer Machines"
are not Singer made needles. 2

ACCESSORIES

No.	Plate	Name
200170B	15870	Attachment Screw
203470	15863	Bobbin (10)
*225482	-----	" Case Screw Driver Blade
*225483	-----	" " " " Handle
225487	15849	Bobbin Case Screw Driver complete, Nos. 225482 and 225483
122 x 13	15867	Needles, twelve, size 16
50447E	15849	Red Bolt (2)
259219	15849	" " Bushing (rubber) (2)
300361C	15849	" " Lock Screw (2)
259220	15849	" Cushion (rubber) (6)
120342	15849	Oiler (copper plated) with 120343
120343	15849	" Spout (3-1/2 in. long)
*225484	-----	Screw Driver Blade
*225485	-----	" " Handle
225498	15849	Screw Driver complete (7-1/4 in. long), Nos. 225484 and 225485
42850	15849	Wrench

BOBBIN WINDER

(SWINGING AUTOMATIC, RIGHT HAND)

225453	15850	Frame with 202277 and 225438
225454	15850	" Hinge Pin
202277	15850	" Oil Packing (wick)
225438	15850	" " Well Cap
225455	15850	" Spring
225456	15850	" " Plunger
202473	15850	Pulley with 200380C
200380C	15850	" Set Screw
225381	15850	Spindle
225444	15850	Stop Latch
200056E	15850	" " Screw
225458	15850	" " Thumb Lever
225459	15850	" " " " Hinge Stud
225459	15850	" " " " Joint Stud
202478	15850	" " Trip Lever
200299H	15850	" " " " Hinge Screw
225461	15850	Tension Bracket with 201499B
200082D	15850	" " Screw
228026	15850	" " " Washer
2102	15850	" Disc
202407	15850	" Spring
201499B	15850	" Stud

No.	Plate	Name
201572B	15850	Tension Stud Thumb Nut
225462	15850	Bobbin Winder Tension Bracket complete, Nos. 201572B, 202407, 225461 and two 2102
259222	15850	Bobbin Winder and Tension Bracket Base
259223	15850	Bobbin Winder complete, Nos. 200056E, 200082D, 200299H, 202473, 202478, 225381, 225444, 225453 to 225456, 225459, 225462 228026, 259222, two each 205419 and wood screws 3/4 in., No. 12, R.H.B.

THREAD UNWINDER

FOR THREE SPOOLS

225259	16257	Spool Rest (for one spool) (flat) with 201018C
225257	16257	Spool Rest (for two spools) (flat) with 201018C
150203	16257	Spool Rest Cushion (felt)
225388	16257	" " Rod
200383C	16257	" " " Set Screw
201018C	16257	" " " Set Screw
202490	16257	" Stand with 200383C
225391	16257	Thread Guide
201696J	16257	" " Lock Nut
225326	16257	" " Position Cup
225324	16257	" " Rod with 208E and 225322
208E	16257	" " " Screw
225322	16257	" " " Washer
259143	16257	Thread Unwinder (for three spools) complete, Nos. 201696J, 202490, 225327, 225259, 225324, 225326, 225388, three each 150203, 225391 and wood screws 7/8 in., No. 12

POWER TABLE ACCESSORIES

For Oblique Set-up on Singer Electric Transmitter Power Table

No.	Plate	Name
259317	15851	Power Table Accessories, Nos. 150491, 259221 and 259225
259221	15851	Belt Guard with two wood screws 3/4 in. No. 12, R.H.B.

Idler

259224	15851	Idler Bracket with 200362C
350362E	15851	" " " Screw
150481	15851	" " Pulley
150482	15851	" " " Shaft
150483	15851	" " " " Ball Bearing
150484	15851	" " " " " " Cover
150485	15851	" " " " " " " Gasket (cork)
330R	15851	Idler Pulley Shaft Ball Bearing Cover Screw
144D	15851	Idler Pulley Shaft Screw
200362C	15851	" " " " Set Screw
150496	15851	Idler Pulley and Shaft complete, Nos. 144D 150481 to 150485 and four 330R
259225	15851	Idler complete, Nos. 150496, 259224 and two 350362E

Starting and Foot Lifter Treadle

6439	15851	Foot Lifter Chain, 36 to 45 in. long, with 56864 and 56865
Note: When ordering No. 6439 state length required.		
4879	15851	Foot Lifter Chain Connecting Link
56864	15851	" " " " Hook (large)
56865	15851	" " " " (small)
150212	15851	" " " Treadle
150487	15851	Starting Treadle with two 140215C
140215C	15851	" " " " Set Screw
150488	15851	" " " " Shaft
150489	15851	" " " " Arm with two 356C
356C	15851	" " " " " Set Screw
46681	15851	" " " " Bracket
60502	-----	" " " " " 46681 with two wood screws 1 in. No. 14
150216	15851	Starting Treadle Shaft Collar with two 445C
445C	15851	Starting Treadle Shaft Collar Set Screw
150490	15851	" " " Spacing Collar

POWER TABLE ACCESSORIES

No.	Plate	Name
150491	15851	Starting and Foot Lifter Treadle complete, Nos. 4879, 6439, 150212, 150216, 150487 to 150490 and two 60500
For Oblique Set-up on Singer Universal Safety Power Table		
259219	15852	Power Table Accessories, Nos. 159497 and 259296
259296	15852	Bobbin Winder Block with two wood screws 1-1/4 in., No. 12
67919	15852	Treadle Pitman Rod (lower)
67920	15852	" " " (upper)
80223	15852	" " " Clamp with 361C
361C	15852	" " " " Set Screw
150208	15852	" " " Spring
2762	15852	" " " " Collar with 362C
362C	15852	" " " " " Set Screw
23250	15852	" " " " Washer
126694	15852	Treadle Pitman Rod complete, Nos. 2762, 67919, 67920, 80223, two each 23250 and 150208
150491	15852	Starting and Foot Lifter Treadle complete, Nos. 4879, 6439, 150212, 150216, 150487 to 150490 and two 60500

Note: For Itemized list of 150491, see above
150497 15852 Starting and Foot Lifter Treadle with Pitman complete, Nos. 126694 and 150491

For Oblique Set-up on Singer Low Shaft**Power Table**

259219	15851	Power Table Accessories, Nos. 259221 and 259225
259221	15851	Belt Guard with two wood screws 3/4 in. No. 12, R. H. B.
259225	15851	Idler complete, Nos. 150496, 259224 and two 350362E

Note: For Itemized list of 259225, see Page 19

DRIVING EQUIPMENT**For Universal Pressed Steel Low Shaft****Power Table**

135068	-----	Front Plank, 1-5/8 in. thick, 19 in. wide 46-1/2 in. long
--------	-------	---

Underdriver

27073	15854	Shaft Pulley (sectional, grooved) 1 3/4 in. diam., 1-3/16 in. bore, with two 597C
597C	15854	Shaft Pulley Clamping Screw
27639	15854	Starting Treadle Pitman Rod

DRIVING EQUIPMENT

No.	Plate	Name
80223	15854	Starting Treadle Pitman Rod Clamp with 361C
361C	15854	Starting Treadle Pitman Rod Clamp Set Screw
60626	15854	Starting Treadle Pitman Rod complete, Nos. 80223 and two 27639
150491	15854	Starting and Foot Lifter Treadle complete, Nos. 4879, 6439, 150212, 150216, 150487 to 150490 and two 60500
Note: For Itemized list of 150491, see Page 20		
150493	15854	Starting and Foot Lifter Treadle with Pitman complete, Nos. 60626 and 150491
126572	15853	Transmitter Belt Guard
126573	15853	" Brake (thermo)
126791	15853	" " Lever with 50058R, 51067C and two 60923
51067C	15853	Transmitter Brake Lever Set Screw
126575	15853	" " " Spring
50058R	15853	" " Screw
25362	15853	" Driving Pulley Ball, size 3/16 inch
204100	15853	Transmitter Driving Pulley Ball Bearing Cup
204101	15853	Transmitter Driving Pulley Ball Cap
227553	15853	Transmitter Driving Pulley Ball Cup complete, Nos. 204100 to 204102 and thirteen 25362
204102	15853	Transmitter Driving Pulley Ball Retaining Spring
126169	15853	Transmitter Driving Pulley (right hand) 6-3/4 in. diam., with 60911, 60935, 126202 and two 126895
60911	15853	Transmitter Driving Pulley (right hand) Friction Ring (leather)
60935	15853	Transmitter Driving Pulley Friction Ring Stop Pin
*126756	-----	Transmitter Driving Pulley Shaft (hollow) (right hand)
*126576	-----	Transmitter Driving Pulley Shaft 126756 with 204107, 204108 and eleven 25303
25303	15853	Transmitter Driving Pulley Shaft Ball, size 1/4 inch
204107	15853	Transmitter Driving Pulley Shaft Ball Cup
204108	15853	Transmitter Driving Pulley Shaft Ball Cup Cap
126757	15853	Transmitter Driving Pulley Shaft Oiling Leather Clip
126578	15853	Transmitter Driving Pulley Shaft Oiling Wick

DRIVING EQUIPMENT

No.	Plate	Name
126173	15853	Transmitter Driving Pulley Shaft Oiling Wick Cover (leather)
126175	15853	Transmitter Driving Pulley Shaft Oiling Wick Plug (leather) (short)
50959C	15853	Transmitter Driving Pulley Shaft Set Screw
204113	15853	Transmitter Driving Pulley Shaft Thimble
126577	15853	Transmitter Driving Pulley Shaft complete, Nos. 126173, 126175, 126576, 126579 and 126757
126895	15853	Transmitter Driving Pulley Spring
126201	15853	" " " " Retaining Washer
126203	15853	Transmitter Driving Pulley Spring Retaining Washer Pin
126202	15853	Transmitter Driving Pulley Spring Retaining Washer complete, Nos. 126201 and 126203
126579	15853	Transmitter Frame with 50959C
126179	15853	" Friction Pulley (right hand) with 227553 and four 50512E
126792	15853	Transmitter Lever (compression) and Dress Guard with 200524C, 204117 and two 202845
204117	15853	Transmitter Lever (compression) Plate
202845	15853	" " " " Rivet
200524C	15853	Transmitter Lever (compression) Shaft Set Screw
126580	15853	Transmitter Lever Shaft
123183	15853	" " " Cotter Pin
423C	15853	" " Stop Screw
60823	15853	" " " " 423C with 1520R
1520R	15853	Transmitter Lever Stop Screw Nut
60489	15853	" Pulley (grooved), 4 in. diameter
50512E	15853	" " Screw
126581	15853	Transmitter complete, Nos. 60489, 123183, 126169, 126179, 126572, 126575, 126577, 126579, 126580, 126791, 126792, 204113 and three wood screws 1-3/4 in., No. 16
150499	15854	Under Driver, lever pressure (right hand) one speed (grooved pulley) complete, Nos. 27073, 126581 and 150498

DRIVING EQUIPMENT

For Old Style Low Shaft Power Table

No.	Plate	Name
135069	-----	Front Plank, 1-5/8 in. thick, 19 in. wide, 48 in. long
150499	15854	Under Driver, lever pressure (right hand) one speed (grooved pulley) complete, Nos. 27073, 126581 and 150498

Note: For Itemized List of 150499, see Page 22

For Universal Electric Transmitter Power Table

135060	-----	Front Plank, 1-5/8 in. thick, 19 in. wide and 46-1/2 in. long, for Series 1500, 1900 and 2900 Motors
135062	-----	Front Plank, 1-5/8 in. thick, 19 in. wide and 46-1/2 in. long, for Series 1700 Motors
135064	-----	Front Plank, 1-5/8 in. thick, 19 in. wide and 46-1/2 in. long, for Series 33 Motors

For Old Style Electric Transmitter Power Table

135061	-----	Front Plank, 1-5/8 in. thick, 19 in. wide and 48 in. long, for Series 1500, 1900 and 2900 Motors
135063	-----	Front Plank, 1-5/8 in. thick, 19 in. wide and 48 in. long, for Series 1700 Motors
135065	-----	Front Plank, 1-5/8 in. thick, 19 in. wide and 48 in. long, for Series 33 Motors

For Universal Safety Power Table

135098	-----	Front Plank, 1-5/8 in. thick, 19 in. wide and 46-1/2 in. long
		Idler
150528	15855	Idler Base with 356C
150491	15855	" Pulley
150492	15855	" " Shaft
150483	15855	" " " Ball Bearing
150484	15855	" " " " " Cover
150485	15855	" " " " " " Gasket (cork)
730R	15855	Idler Pulley Shaft Ball Bearing Cover Screw
150529	15855	Idler Pulley Shaft Bracket (lower) with 169C and 692C
150530	15855	Idler Pulley Shaft Bracket (upper) with 169C and 692C

DRIVING EQUIPMENT

No.	Plate	Name
692C	15855	Idler Pulley Shaft Bracket Clamping Screw
150531	15855	Idler Pulley Shaft Bracket Shaft
356C	15855	" " " " " Set Screw
144D	15855	Idler Pulley Shaft Screw
168C	15855	" " " Set Screw
150496	15855	Idler Pulley and Shaft complete, Nos. 144D 150481 to 150485 and four 330R
150532	15855	Idler complete, Nos. 150528 to 150531, two 150496 and three wood screws 1-1/4 in. No. 12, F.H.
150523	15855	Idler Guard with two wood screws 3/4 in. No. 9

STANDS

STAND No. 46922
FOR TABLE No. 29734SERIES 59 MOTOR
PARALLEL SET-UP

6439	15857	Foot Lifter Chain, 36 to 45 in. long, with 56864 and 56865
Note: When ordering No. 6439, state length required.		
4879	15857	Foot Lifter Chain Connecting Link
56864	15857	" " " Hook (large)
56865	15857	" " " " (small)
46826	15856	" " Treadle
46879	15856	" " " 46836 with 276C and 67665
67665	15856	Foot Lifter Treadle Extension
2762	15856	" " " " Collar with 362C
362C	15856	Foot Lifter Treadle Extension Collar Set Screw
126508	15856	Leg
46707	15857	" Brace with wood screw 1 in. No. 16, F.H.
126530	15856	Leg Cross Member, 15-1/2 in. long
51057N	15856	" " " Bolt with 1522R
1522R	15856	" " " " Nut
126509	15856	" " " " Socket Washer
12620	15856	" " " " Washer
51038R	15857	" Foot Lag Screw
9842	15857	" " " " Washer
126758	15856	Leg with Rail complete, Nos. 126530, 126532 two 126508, three 12620 and four each 51057N and 126509

STANDS

No.	Plate	Name
152028	15857	Motor Pitman Rod (lower)
152029	15857	" " " (upper)
80223	15857	" " " Clamp with 361C
361C	15857	" " " " Screw
2762	15857	" " " Collar with 362C
362C	15857	" " " " Set Screw
150208	15857	" " " Spring
2762	15857	" " " Adjusting Collar with 362C
362C	15857	Motor Pitman Rod Spring Adjusting Collar Set Screw
23250	15857	Motor Pitman Rod Spring Washer
152030	15857	Motor Pitman Rod complete, Nos. 23250, 80223, 150208, 152028, 152029 and two 2762
152018	15857	Oil Can Holder
152019	15857	" " " 152018 with 9842, 51083R and 67425
51083R	15857	Oil Can Holder Bolt with 51501R
51501R	15857	" " " " Nut
67425	15857	" " " " Lock Washer
9842	15857	" " " " Washer
126532	15856	Rail, 16 in. long
51057N	15856	" Bolt with 1522R
1522R	15856	" " Nut
126509	15856	" " " Socket Washer
12620	15856	" " Washer
46707	15857	Starting Treadle
152021	15856	" " 152021 with 2718R, 46692 and 50541R
46692	15856	Starting Treadle Extension
50541R	15856	" " " " Screw
2718R	15856	" " " " Washer
152028	15857	" " Pitman Rod (lower)
152029	15857	" " " " (upper)
80223	15857	" " " " Clamp with 361C
361C	15857	Starting Treadle Pitman Rod Clamp Set Screw
152032	15857	Starting Treadle Pitman Rod complete, Nos. 80223 and two 152028
152033	15856	Starting Treadle Rock Shaft, 28 in. long
46838	15856	" " " " Arm with two 356C
356C	15856	Starting Treadle Rock Shaft Arm Set Screw
46453	15856	Starting Treadle Rock Shaft Collar with two 454C
454C	15856	Starting Treadle Rock Shaft Collar Set Screw

STANDS

No.	Plate	Name
46839	15856	Starting Treadle Rock Shaft Support Bracket with two 362C
46840	15856	Starting Treadle Rock Shaft Support Rod 16-15/16 in. long
46841	15856	Starting Treadle Rock Shaft Support Rod 46840 with two 1795R and four 12620
1795R	15856	Starting Treadle Rock Shaft Support Bracket Rod Nut
12620	15856	Starting Treadle Rock Shaft Support Bracket Rod Washer
362C	15856	Starting Treadle Rock Shaft Support Bracket Set Screw
46803	15856	Treadle Position Collar with 51089R
51089R	15856	" " " Clamping Bolt with 51581R
51581R	15856	Treadle Position Collar Clamping Bolt Nut
152034	15856	Treadle Support, 42 in. long
46805	15856	" " Bracket
839R	15856	" " " Bolt
126509	15856	" " " " Socket Washer
12620	15856	" " " " Washer
152035	15856	" " Equalizer with two 200341C
200341C	15856	" " " Set Screw
46922	15858	Stand (steel work) complete, Nos. 46739, 6439, 46879, 152019, 152030 to 152035, two each 839R, 12620, 46483, 46803, 46805, 46838, 46839, 46841, 126509, 126758 three 46707, eight each 9842 and 51038R

STAND No. 46921

FOR TABLE No. 29755

SERIES 59 MOTOR

OBLIQUE SET-UP

6439	15854	Foot Lifter Chain, 36 to 45 in. long, with 56864 and 56865
Note: When ordering No. 6439, state length required.		
4879	15854	Foot Lifter Chain Connecting Link
56864	15854	" " " Hook (large)
56865	15854	" " " " (small)
150212	15854	" " Treadle
126508	15856	Leg
46707	15857	" Brace with wood screw 1 in., No. 16 F.H.

STANDS

No.	Plate	Name
126530	15856	Leg Cross Member, 15-1/2 in. long
51057N	15856	" " " Bolt with 1522R
1522R	15856	" " " " Nut
126509	15856	" " " " " Socket Washer
12620	15856	" " " " " Washer
51039R	15857	" Foot Lag Screw
9842	15857	" " " " " Washer
126758	15856	Leg with Rail complete, Nos. 126530, 126532, two 126509, three 12620, four each 51057N and 126509
46843	15859	Motor Pitman Rod (lower)
152005	15859	" " " (upper)
80223	15859	" " " Clamp with 361C
361C	15859	" " " " " Screw
2762	15859	" " " Collar with 362C
362C	15859	" " " " Set Screw
150208	15859	" " " Spring
23250	15859	" " " " Washer
2762	15859	" " " " Adjusting Collar with 362C
362C	15859	Motor Pitman Rod Spring Adjusting Collar Set Screw
152006	15859	Motor Pitman Rod complete, Nos. 23250, 46843, 80223, 150208, 152005 and two 2762
152018	15857	Oil Can Holder
152019	15857	" " " 152018 with 9842, 51082R and 67425
51082R	15857	Oil Can Holder Bolt with 51581E
51581E	15857	" " " " " Nut
67425	15857	" " " " " Lock Washer
9842	15857	" " " " " Washer
126532	15856	Rail, 16 in. long
51057N	15856	" Bolt with 1522R
1522R	15856	" " Nut
126509	15856	" " " Socket Washer
12620	15856	" " Washer
152007	15859	Starting Lever Rock Shaft
11459	15859	" " " " " Belt Shifter Collar with two 448C
448C	15859	Starting Lever Rock Shaft Belt Shifter Collar Set Screw
152008	15859	Starting Lever Rock Shaft Holder
152009	15859	" " " " " 152008 with 12620, 126841 and two 1522P
126841	15859	Starting Lever Rock Shaft Holder Clamping Plate
1522P	15859	Starting Lever Rock Shaft Holder Nut
12620	15859	" " " " " Washer
150109	15859	" Rod Rock Shaft Arm with 356C

15839 - 2/3

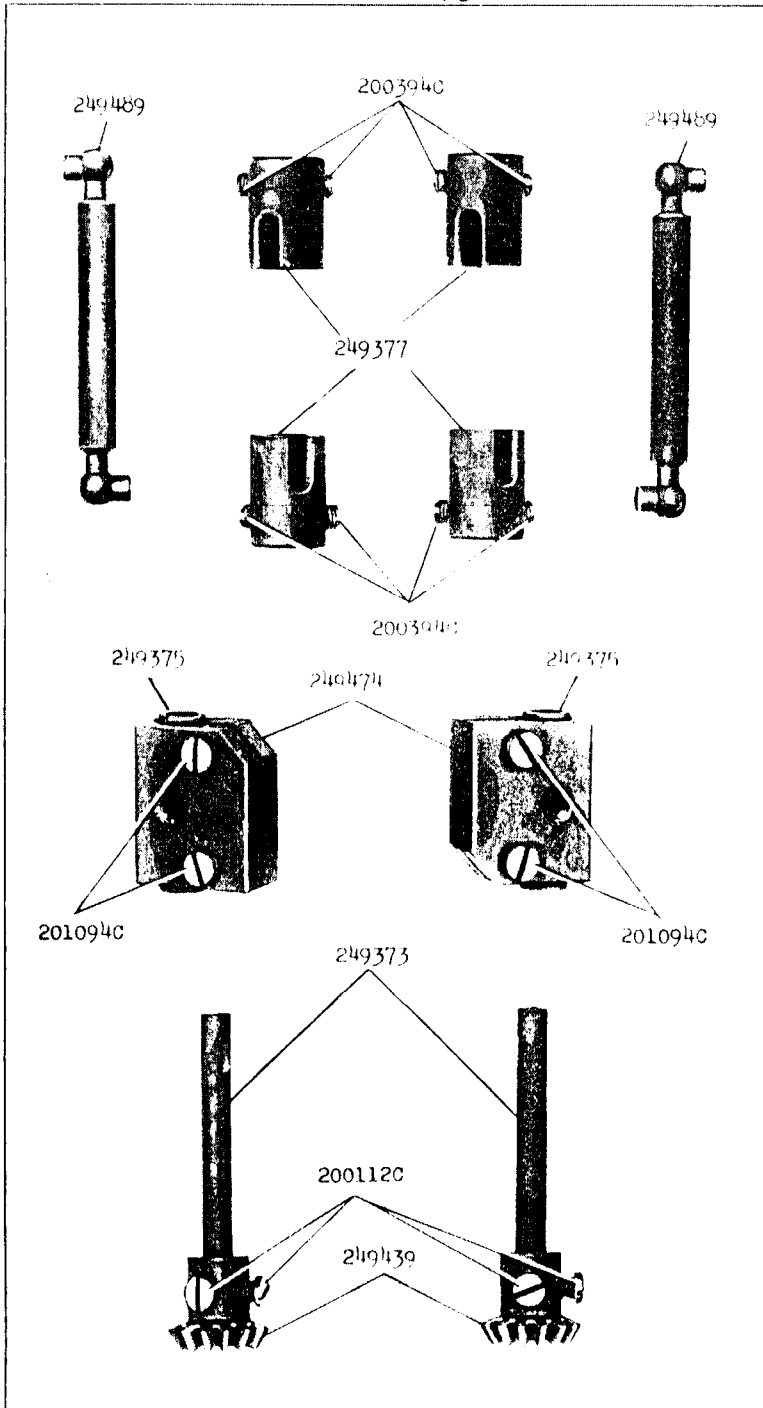

15840 - 3/8

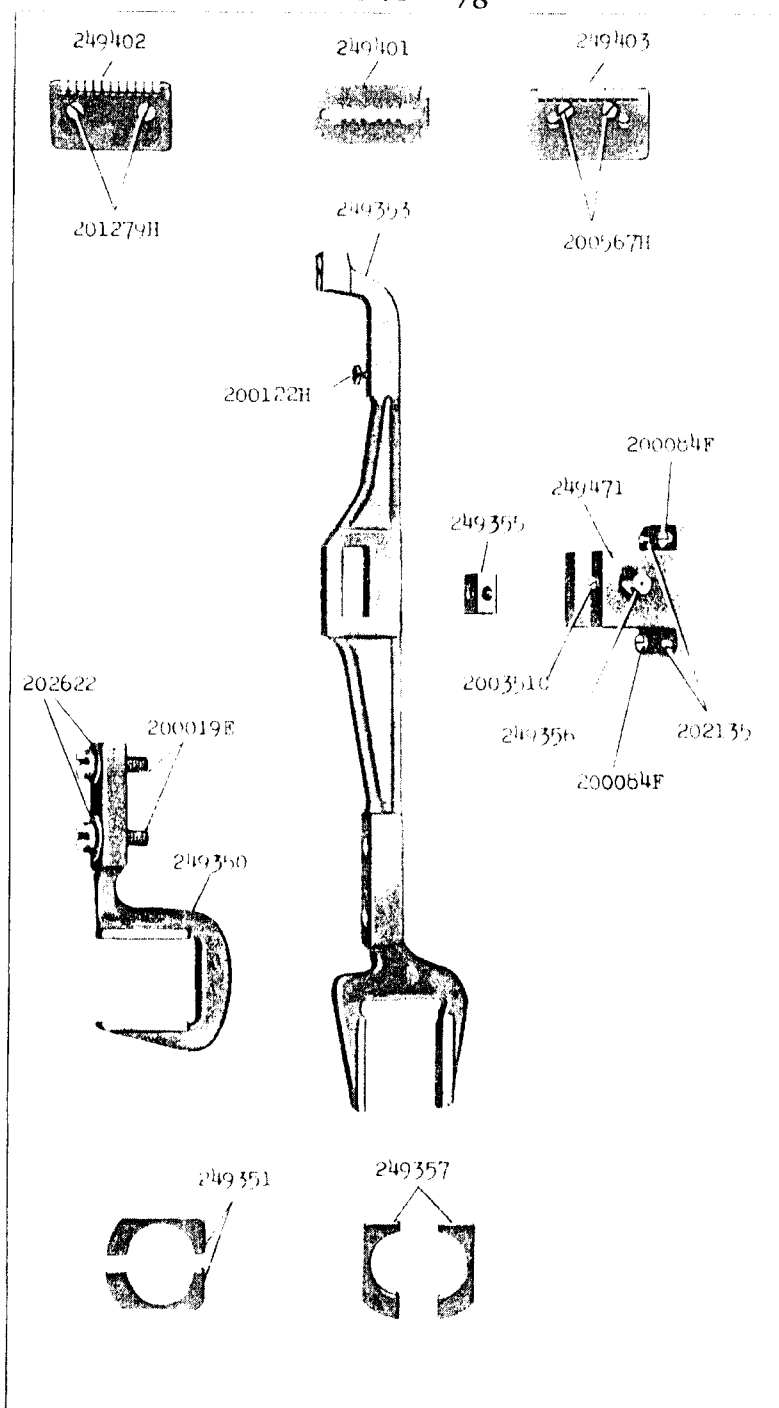

15844 - 3/8

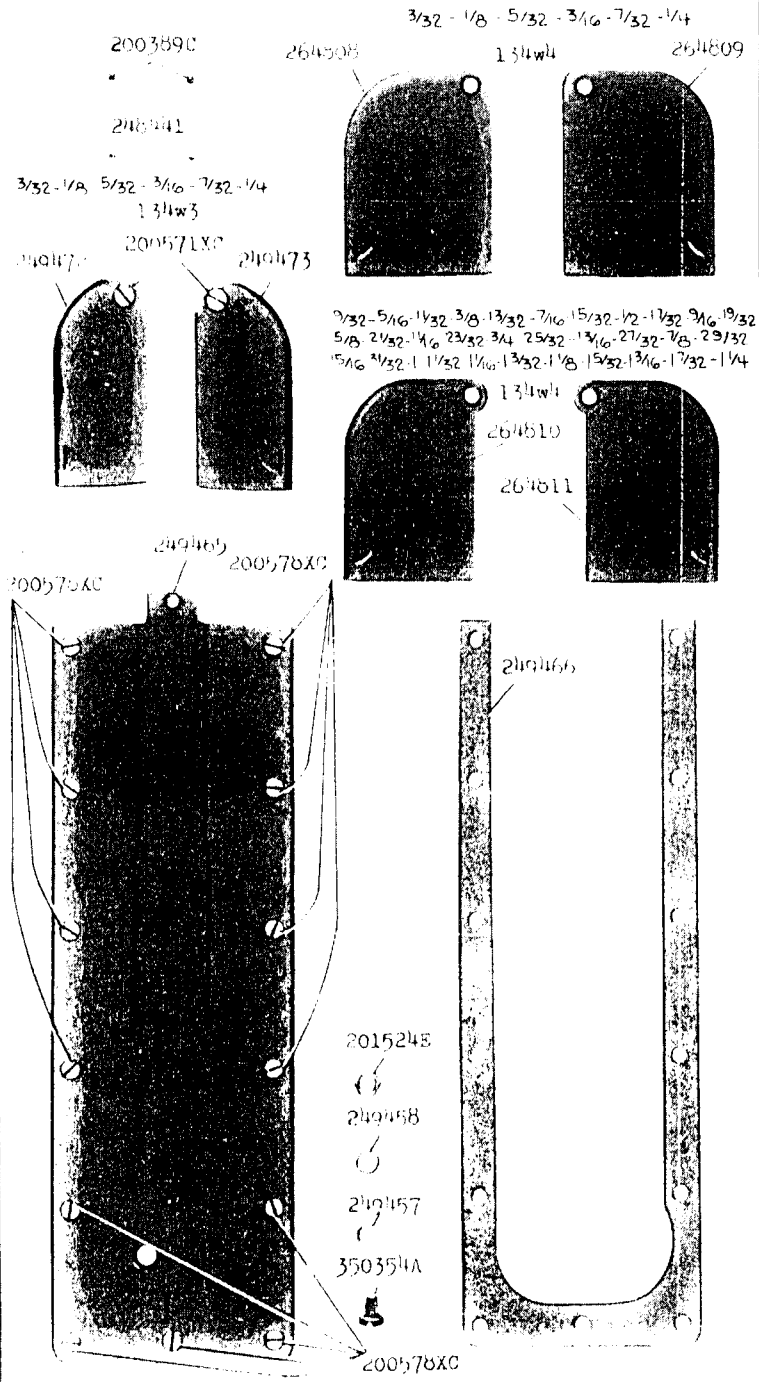

15845 - 1/4

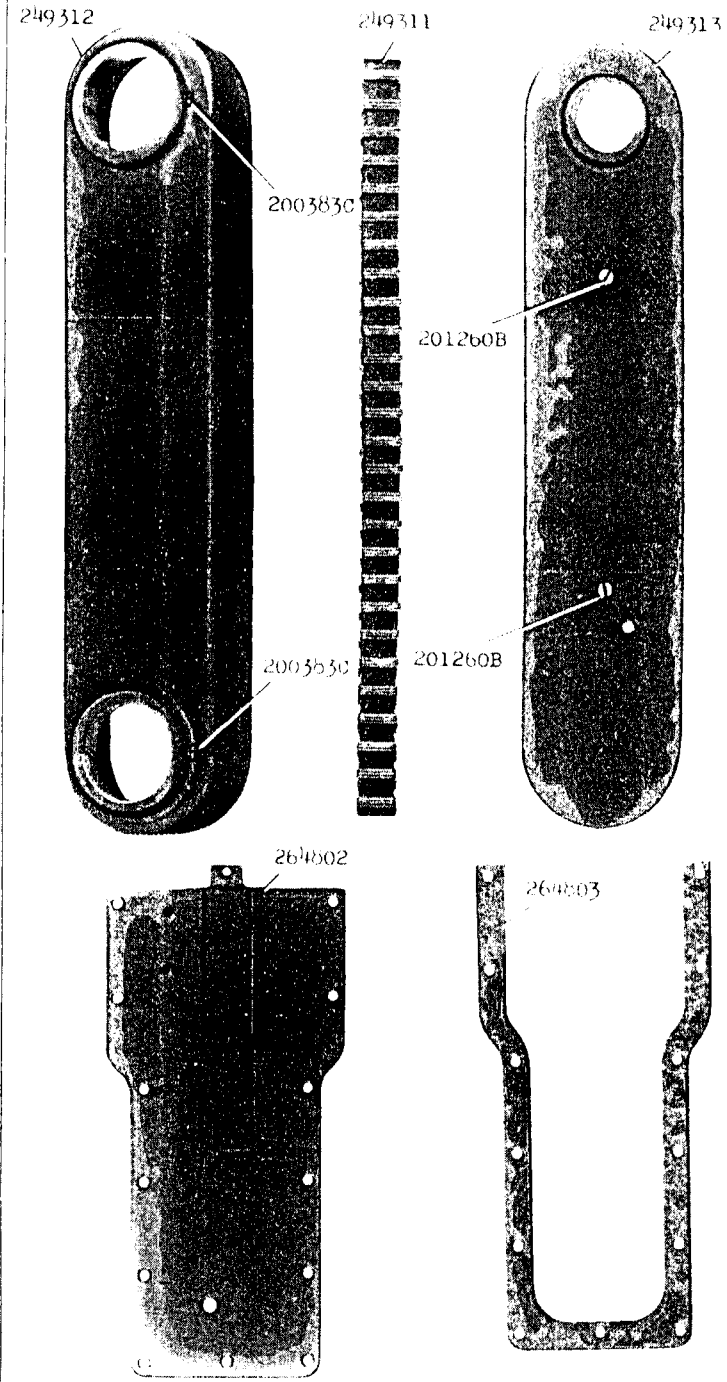

15846 - 3/8

249470

134W3

3/32 - 1/8 - 5/32 - 3/16 - 7/32 - 1/4



249469

249467



249468



201537E



201020E

264815

134W4

3/32 - 1/8 - 5/32 - 3/16 - 7/32 - 1/4 - 9/32 - 5/16 - 1/2 - 3/8 - 3/52
7/16 - 15/32 - 1/2 - 7/32 - 9/16 - 19/32 - 5/8



264814

264812



264813



201537E



201020E

264807

134W4

2/32 - 1/16 - 23/32 - 3/4 - 25/32 - 3/16 - 27/32 - 7/8 - 29/32 - 5/16
3/32 - 1 - 1/32 - 1/16 - 13/32 - 1/8 - 15/32 - 3/16 - 17/32 - 1/4



264806

264804



264805

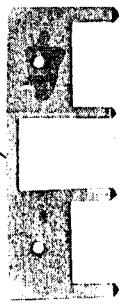

201537E



201020E

15849 - 3/8

225498



225497



120342

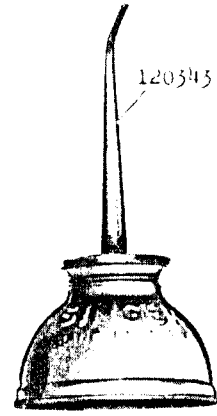

120345

42850



259220



259220

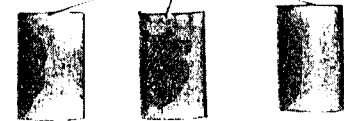

503610



504478

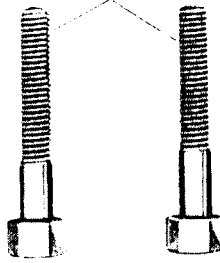

259219



15852 - 1/6

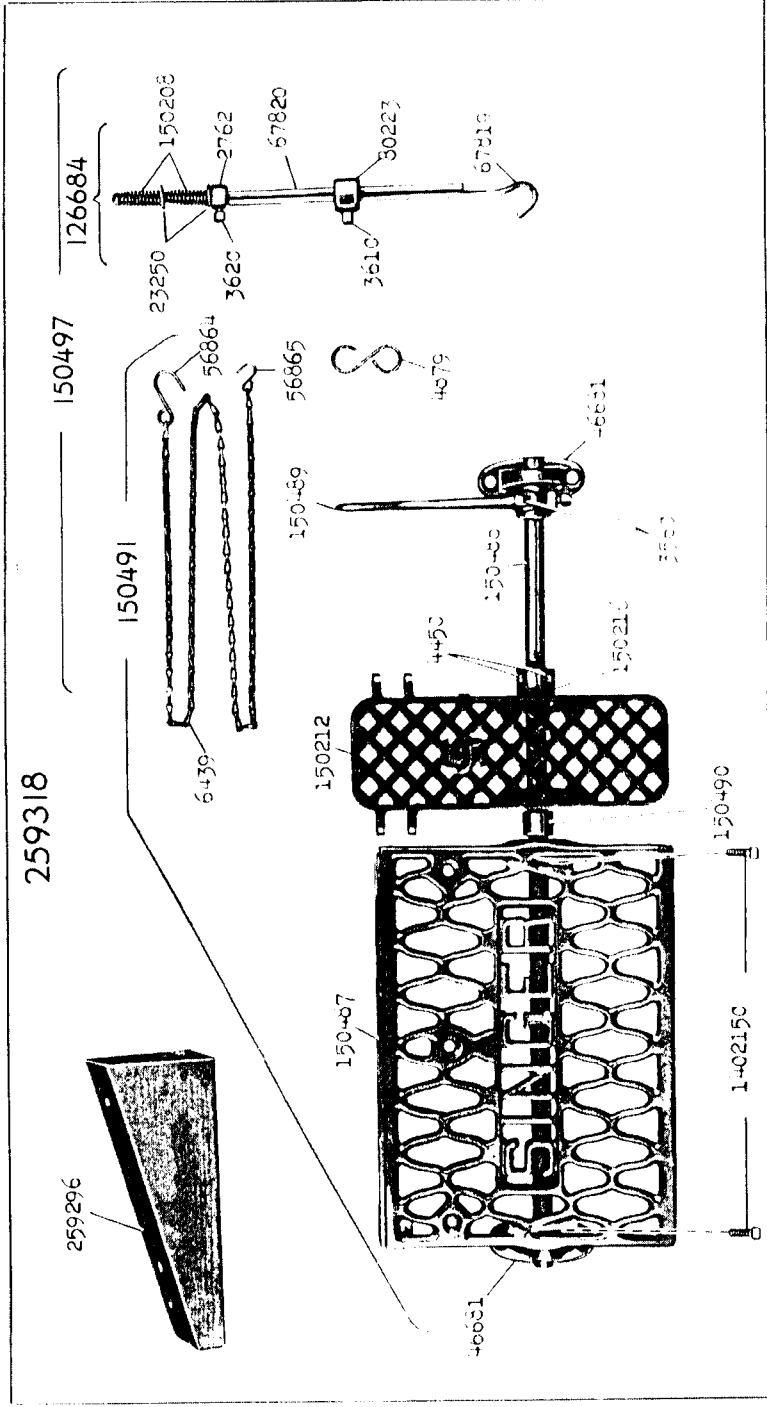

15853 - 1/6

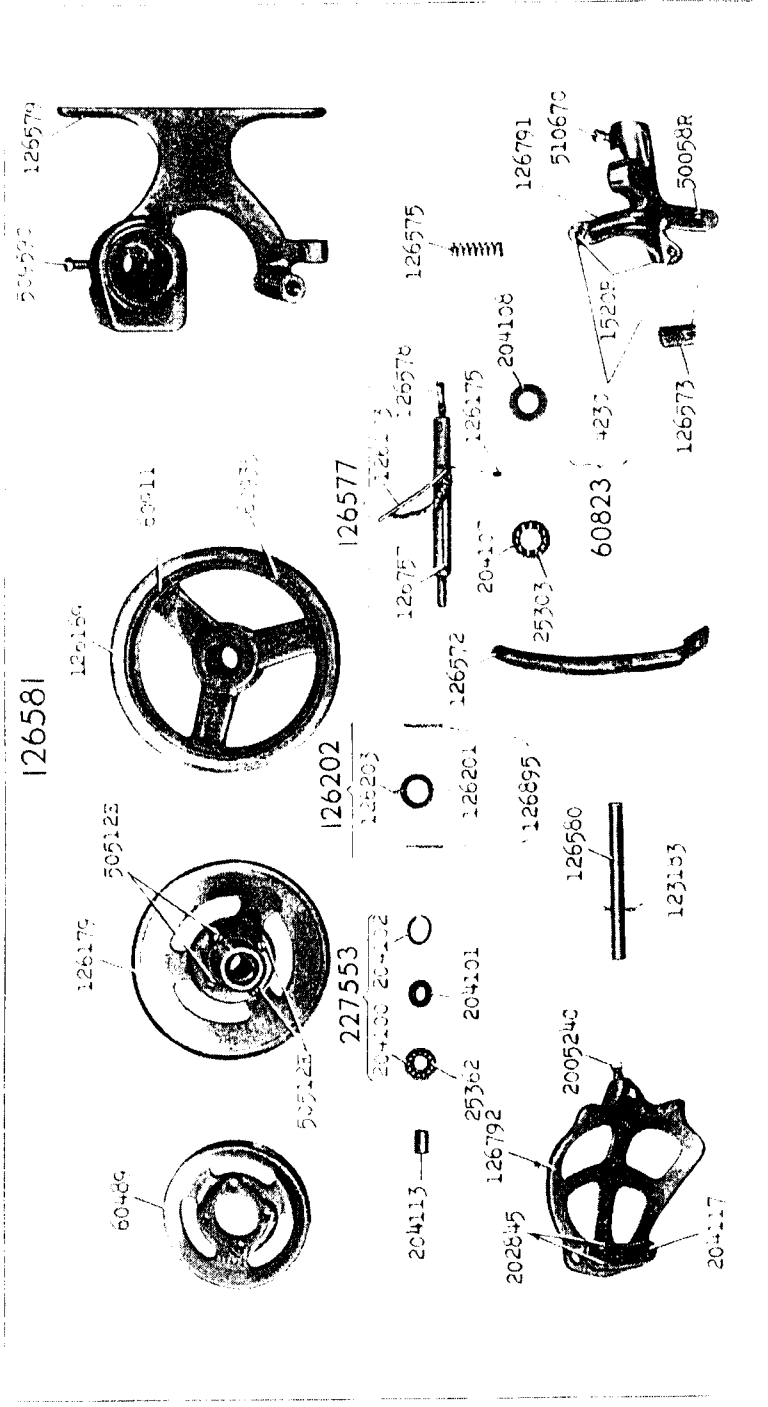

126758 (2)

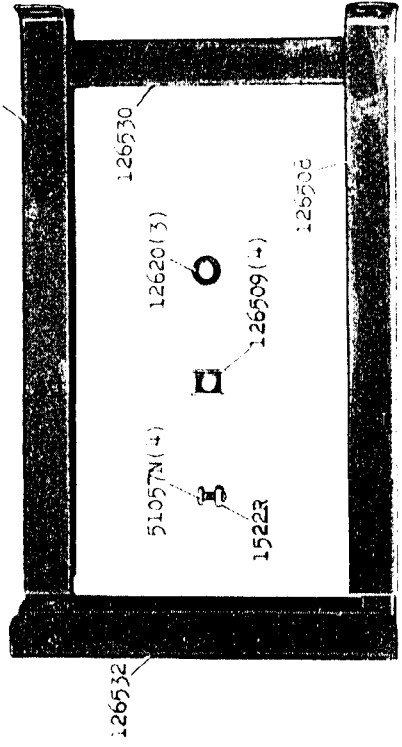

152031

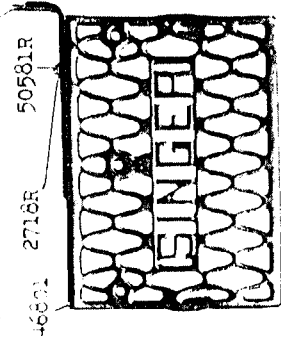

46879

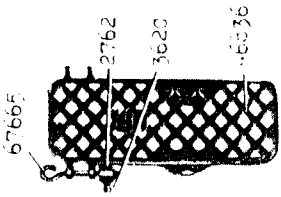

15856 - 1/8

46841

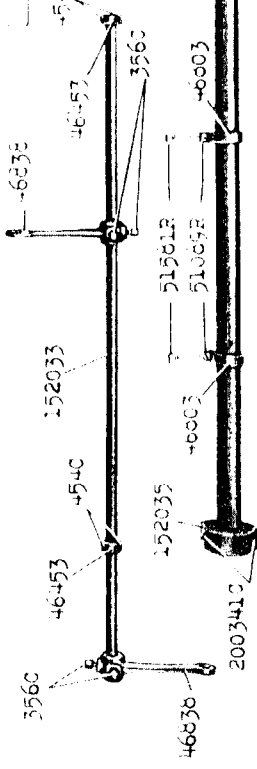
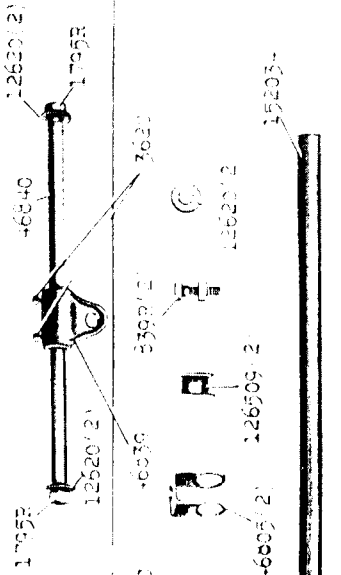

15857 - 1/4

152030

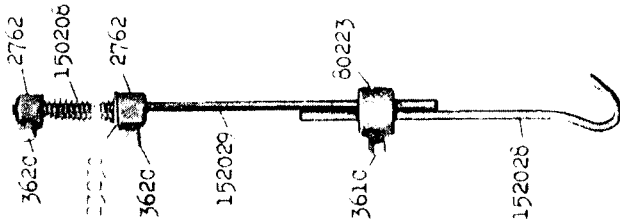

152032

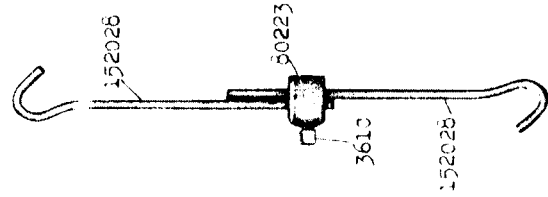

152019

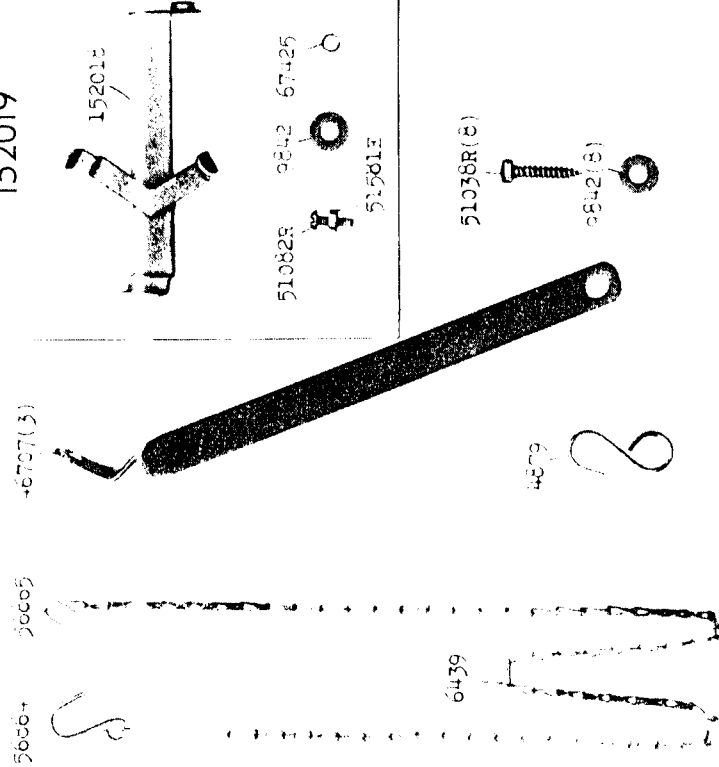

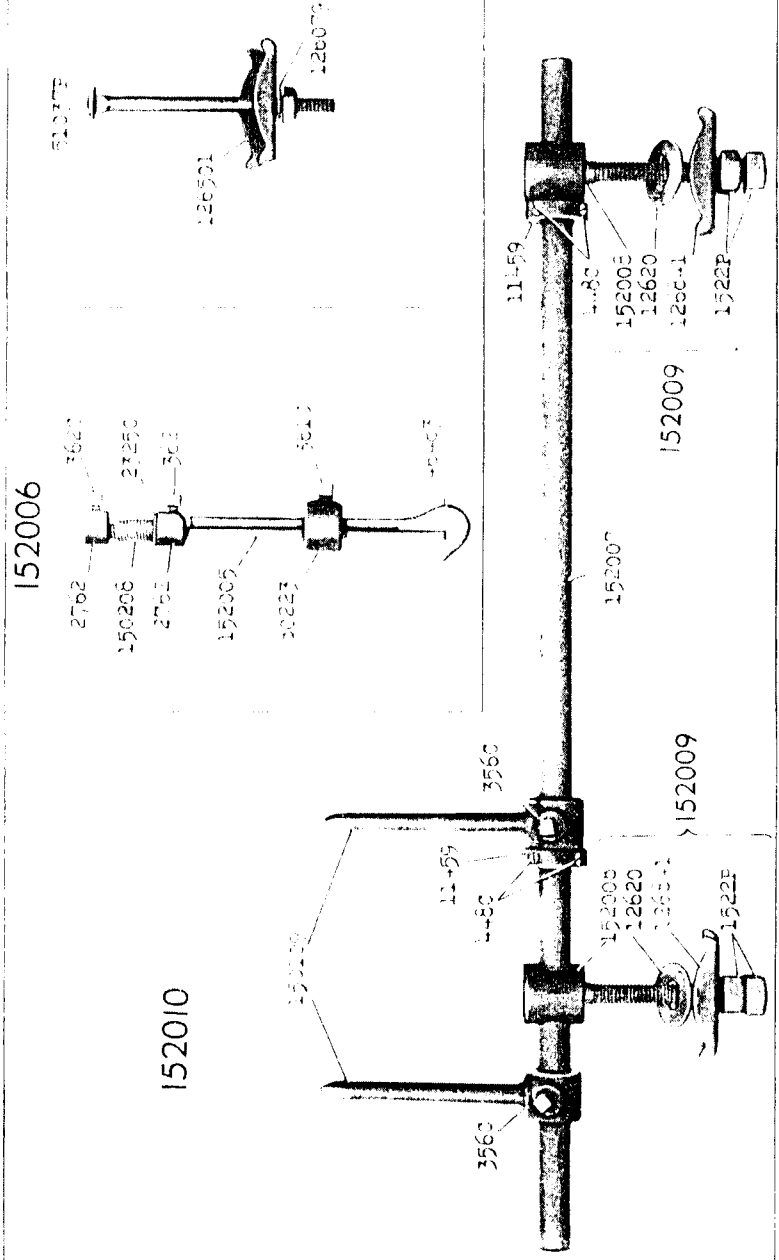
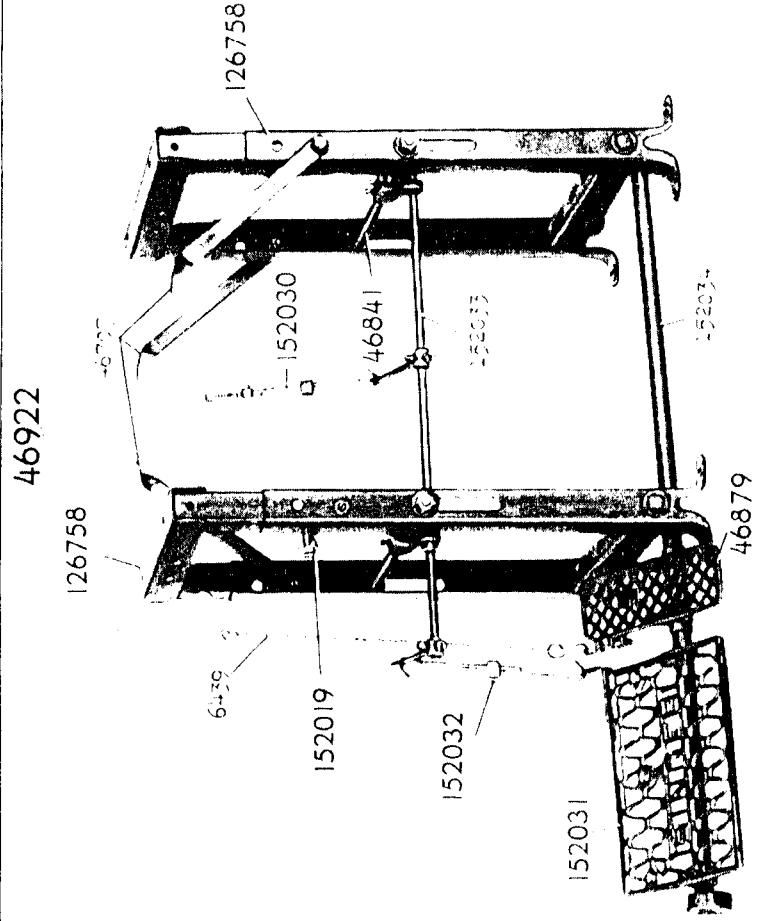

15863

249363

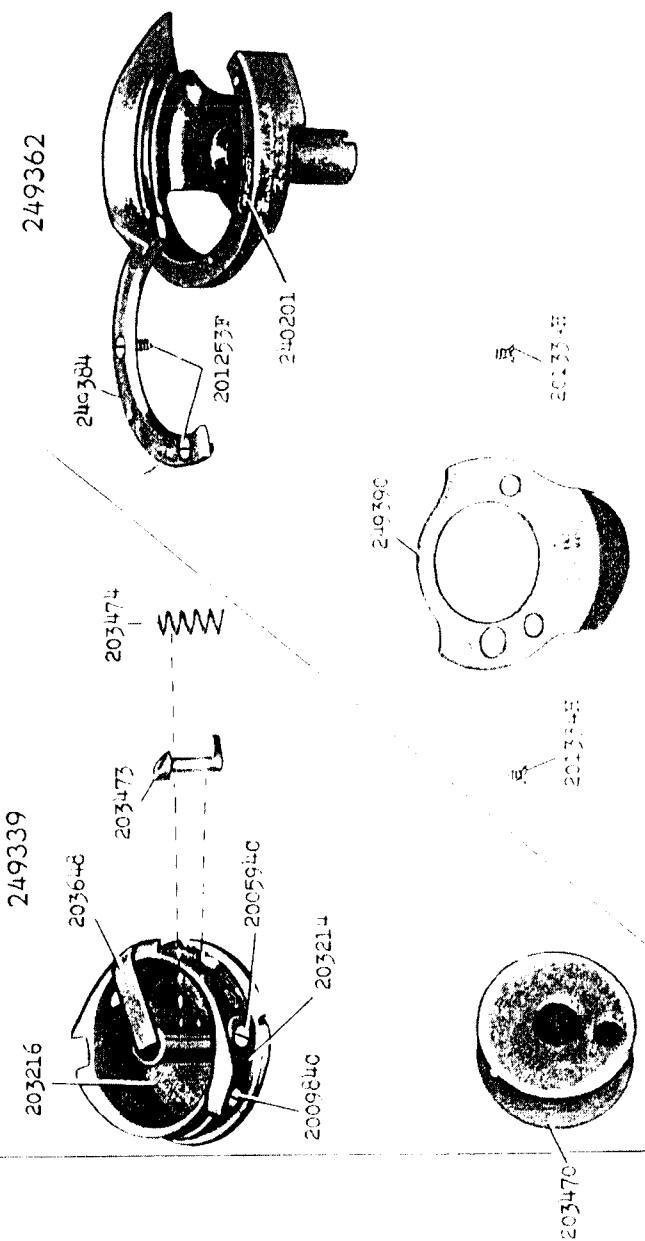

15864

249364

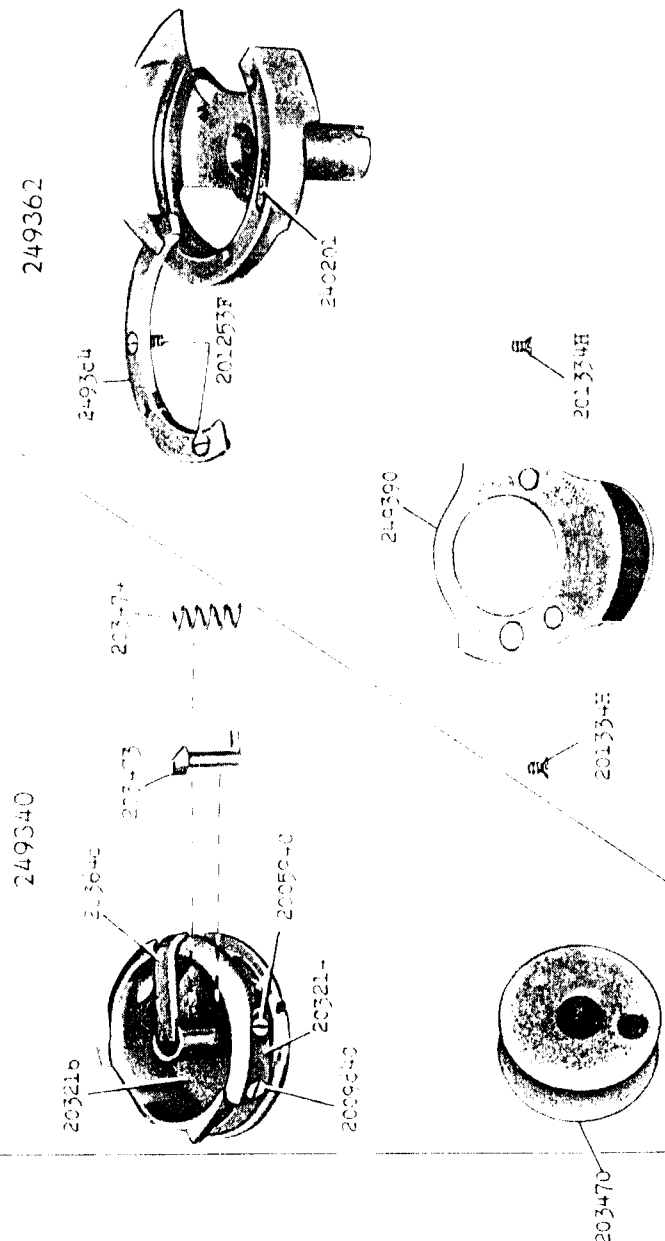

15865 - 1/2
249484

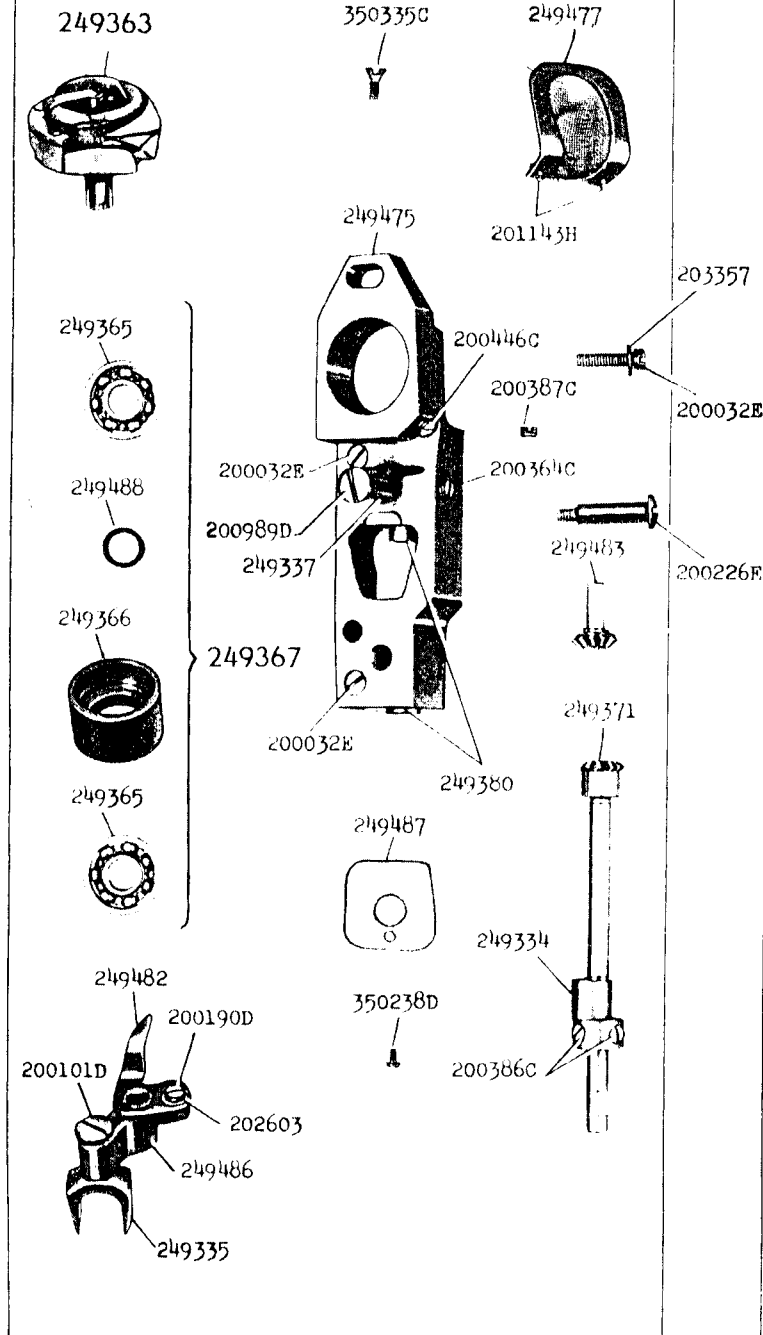

15866 - 1/2
249485

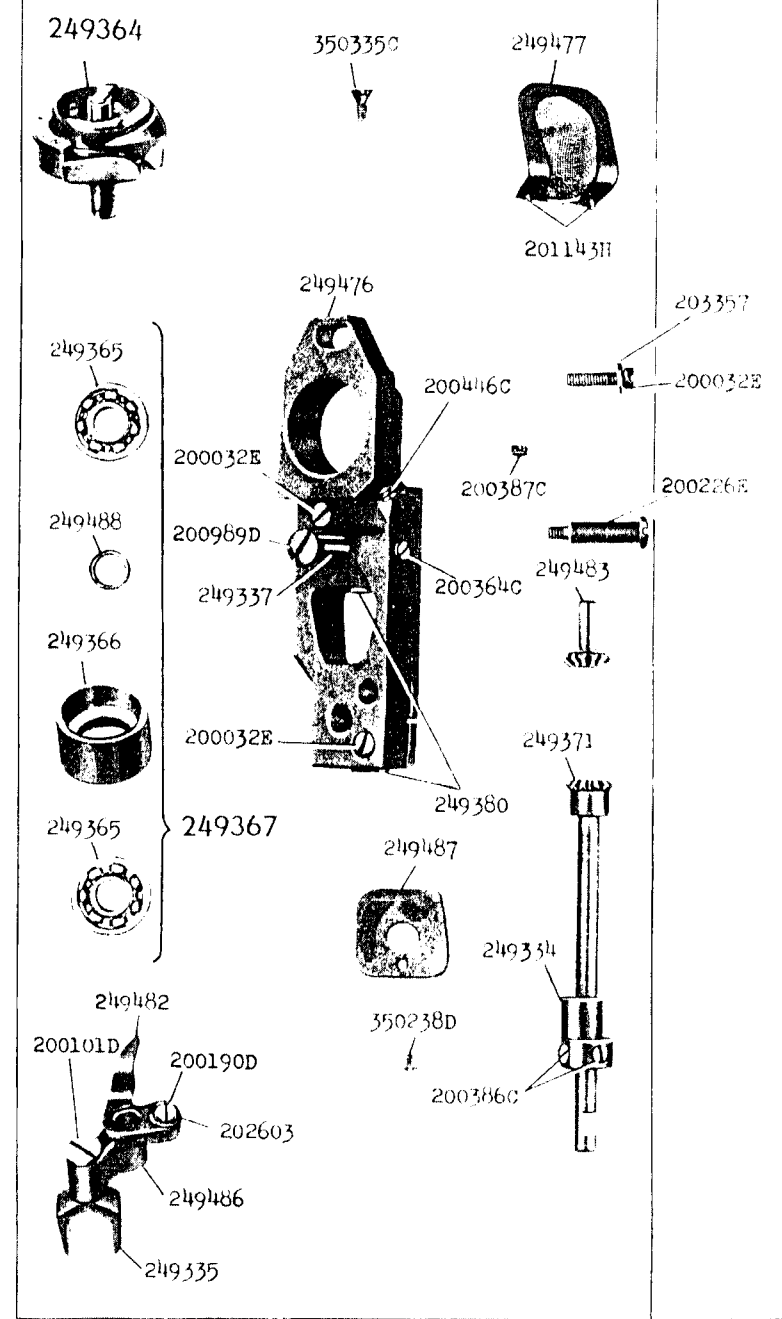

15867 - 1/2

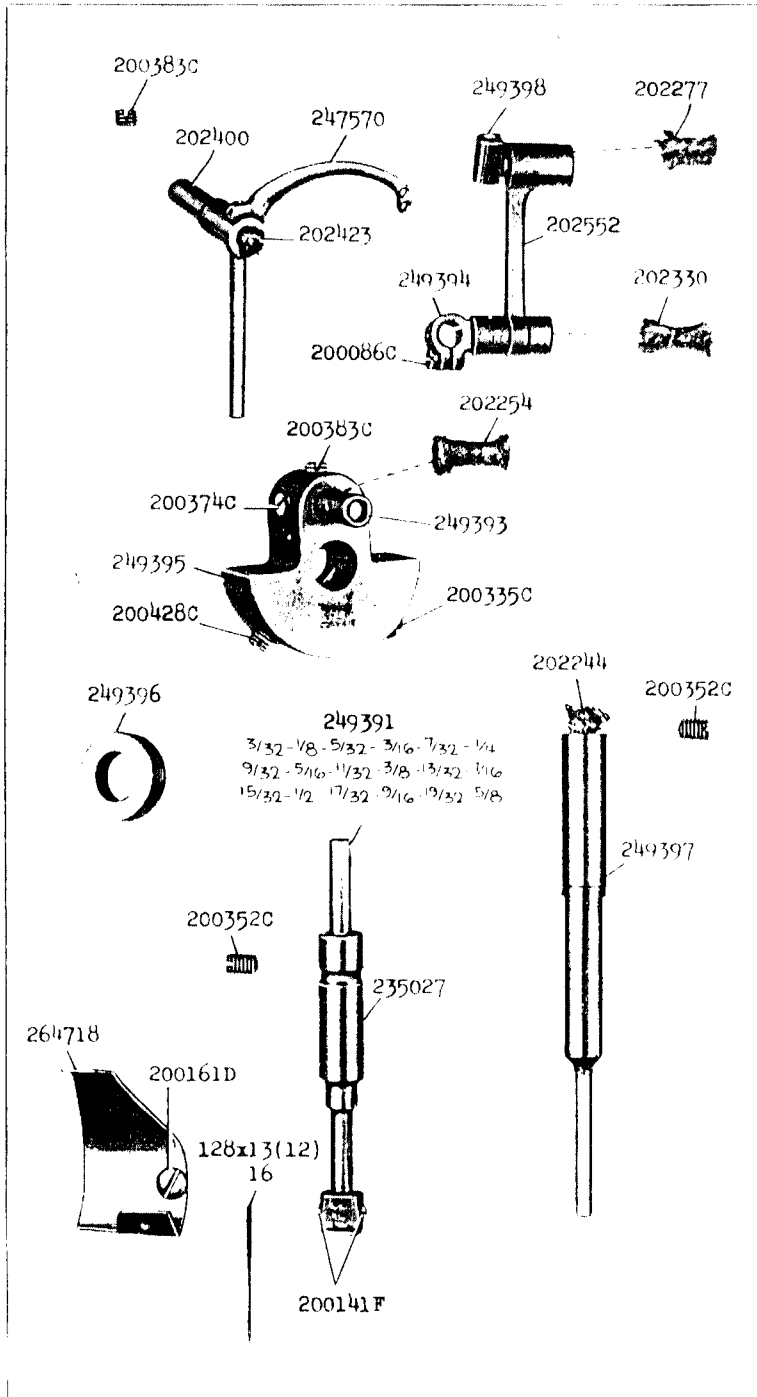

15868 - 1/2

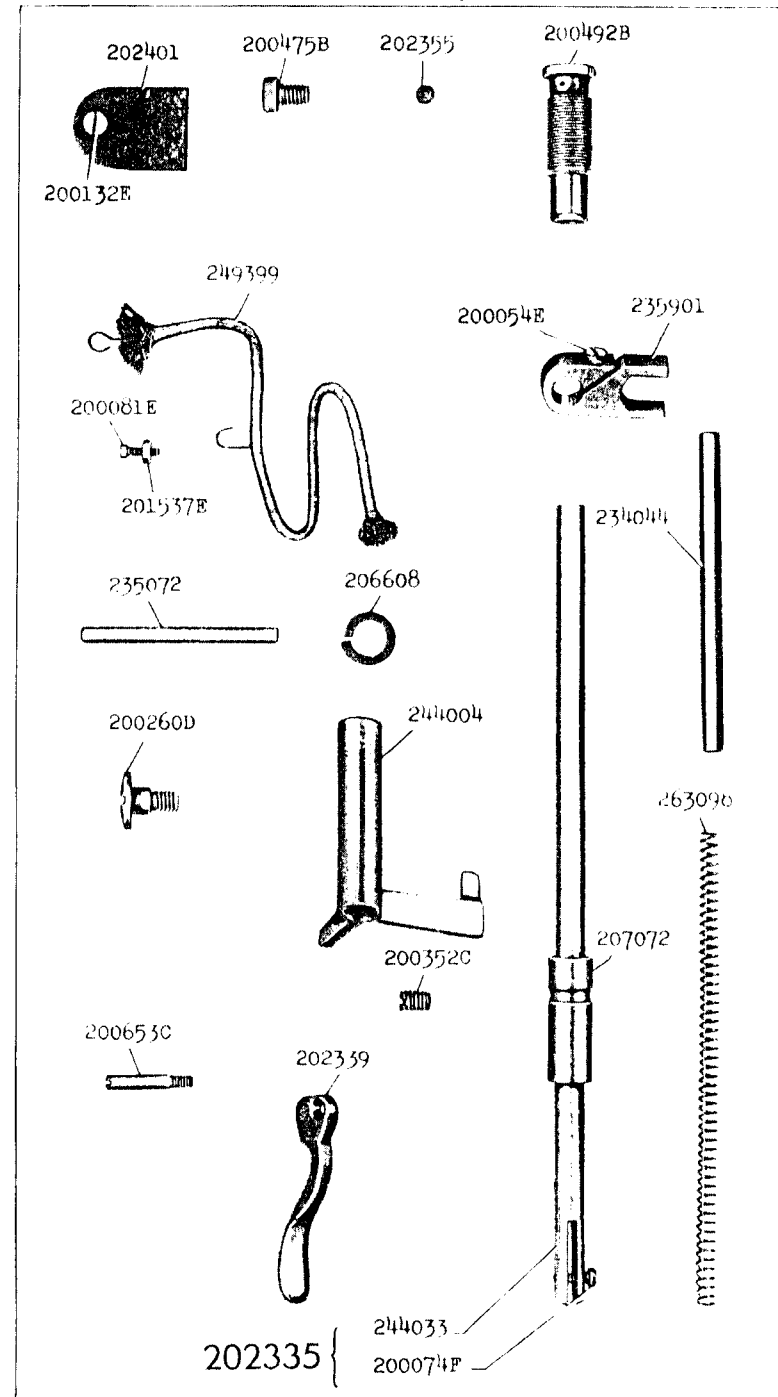

15869 - 1/2

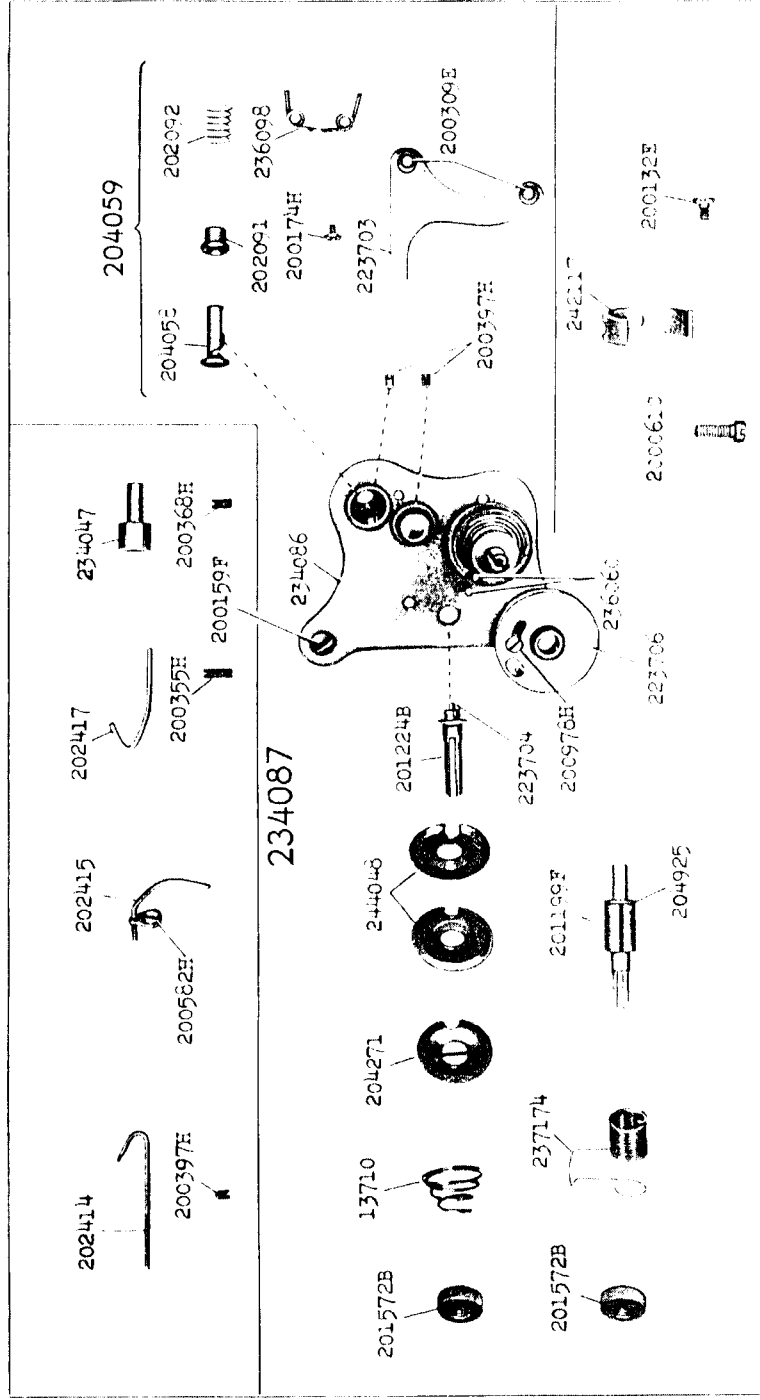

15870 - 3/8

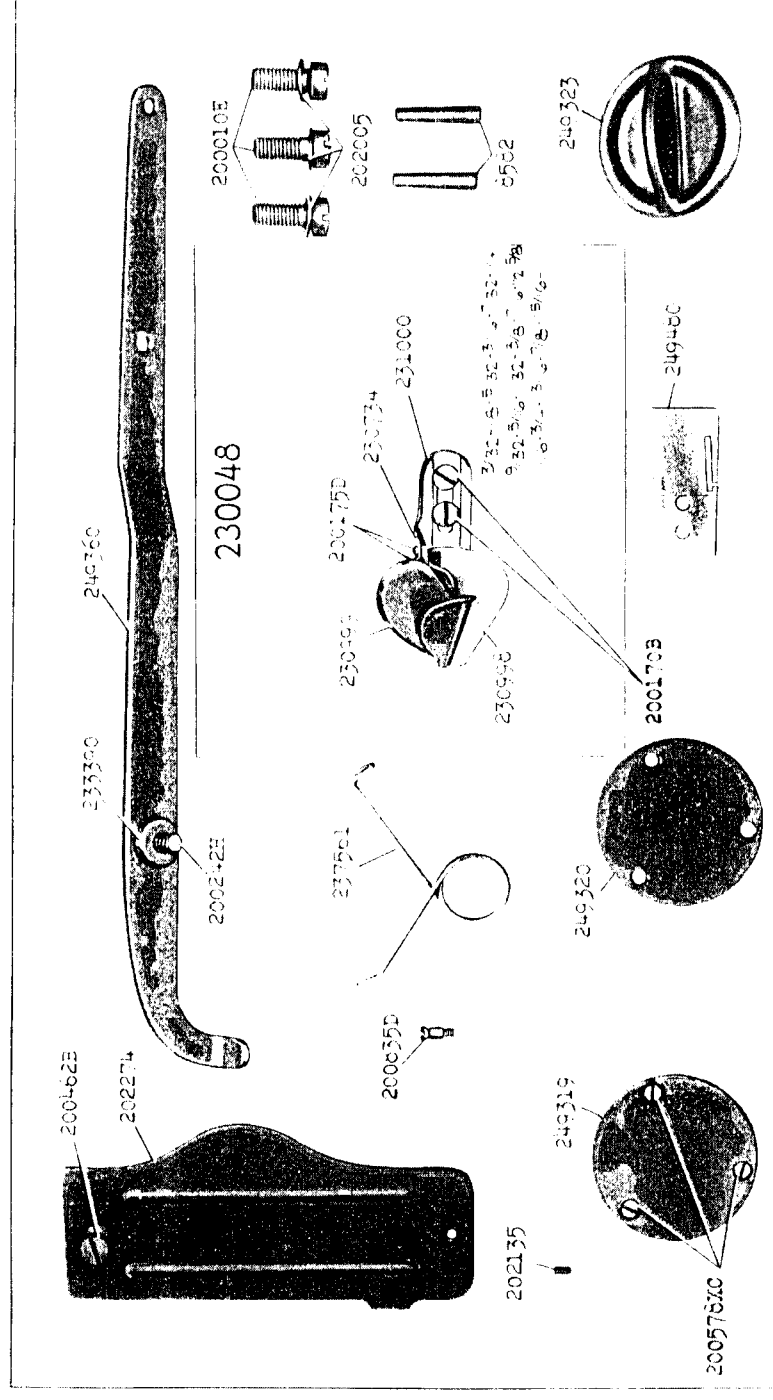

15871 - 2/3

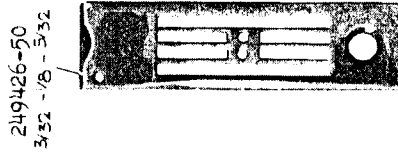
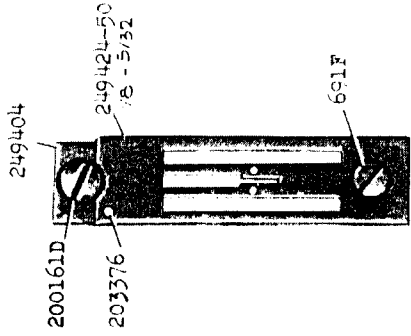
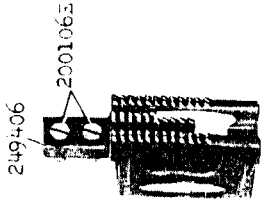
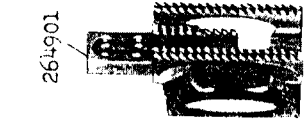

15872 - 2/3

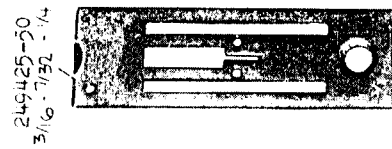
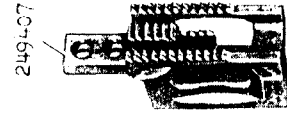

229167 - 46

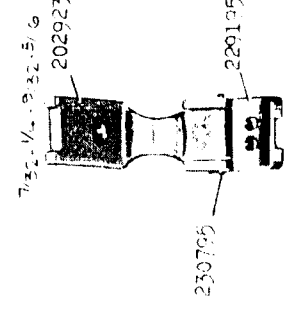

229194 - 46

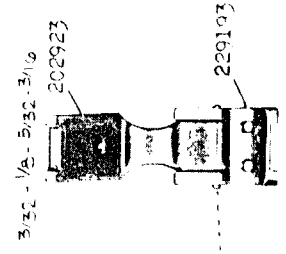

15873 - 1/10

29734



29755

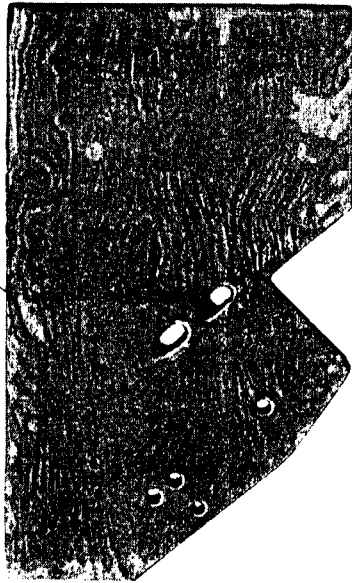

16257 - 1/6

259143

