

Form 19495  
( 940 )  
Printed in U. S. A.

# LIST OF PARTS



MACHINES  
Nos. 176-21 and 176-22

---

THE SINGER MANUFACTURING COMPANY

## INSTRUCTIONS FOR OILING

To ensure easy running and prevent unnecessary wear of the parts which are in movable contact, the machines require oiling each day.

Apply Singer "Stainless Oil for High Speed Sewing Machines" to all oil holes accessible from the outside. Remove the top cover and the front cover and lubricate all oiling points thus uncovered.

Copyright, U. S. A., 1939 and 1940  
by The Singer Manufacturing Co.  
All Rights Reserved for all Countries

## INSTRUCTIONS FOR ORDERING

In ordering from this list, use ONLY the part NUMBER in the FIRST column.

The number stamped on a Sewing Machine Part is in every case the number of the single part only.

Every combination of parts sent out as such has its specific number, which, although not stamped on the parts, must be used when ordering the combination.

Each number always indicates the SAME PART in whatever list it appears, or for whatever machine.

The letters after some of the numbers indicate the style of finish only, as follows:

- A-Hardened, Polished, Nickel Plated and Buffed
- A.A-Buffed and Chromium Plated
- A.B-Hardened, Polished, Buffed and Chromium Plated
- A.C-Brown Baking Enamel Finish
- A.D-Gray Baking Enamel Finish
- A.E-Hardened, Bright Rumbled and Nickel Plated
- A.F-Hardened, Bright Rumbled, Nickel Plated, Bright Rumbled and Chromium Plated
- B-Polished, Nickel Plated and Buffed
- C-Hardened Only
- C.R-Hardened and Merlized
- D-Polished Only
- E-Soft, Not Polished
- F-Hardened and Polished
- F.J-Hardened, Polished and Nickel Plated
- G-Bright Rumbled and Nickel Plated
- H-Blued
- J-Nickel Plated Only
- K-Hardened and Nickel Plated
- L-Brass Plated
- M-Oxidized
- N-Japanned, Dull
- P-Japanned, Bright
- P.P-Wrinkle Finish
- R-Merlized
- S-Cadmium Plated
- T-Copper Plated
- T.A-Hardened, Polished, Copper and Nickel Plated and Buffed
- T.B-Copper and Nickel Plated and Polished
- T.J-Copper and Nickel Plated Only
- T.K-Hardened, Copper and Nickel Plated
- T.L-Copper and Brass Plated
- T.M-Copper Plated and Oxidized
- U-Zinc Plated
- V-Silver Plated
- W-Polished and Nickel Plated
- X-Black Oxide, for Iron and Steel
- X.C-Hardened and Black Oxide, for Iron or Steel
- Y-Black Nickel Plated Only
- Z-Chromium Plated
- Z.A-Hardened, Polished, Nickel Plated, Buffed and Chromium Plated
- Z.B-Polished, Nickel Plated, Buffed and Chromium Plated
- Z.C-Hardened and Chromium Plated
- Z.D-Polished and Chromium Plated
- Z.G-Bright Rumbled, Nickel Plated, Bright Rumbled and Chromium Plated
- Z.J-Nickel and Chromium Plated
- Z.T-Copper and Chromium Plated

These letters MUST BE USED when they appear in the list; and AFTER the number as in the list.

In this series:

- 1 to 1500, 50001 to 51500 and 140001 to 142000 are Screw Numbers
- 1501 to 1800 and 51501 to 51800 are Nut Numbers
- 1801 to 2000 and 51801 to 52000 are Roller Numbers
- 2001 to 50000 and 52001 to 140000 and 142001 to 190000 are Sewing Machine Parts, 190001 and upward are numbers of Electrical Parts.

The figures in the second column refer only to the plates, illustrating the parts, and are NOT TO BE USED in ordering.

Parts marked with an asterisk (\*) are furnished only when repairs are made at factory.

## INDEX

	Page
Accessories.....	16
Feeding Disc Opening and Starting Parts.....	16
Machine Bases.....	16
Machine No. 176-21.....	5
Machine No. 176-22.....	11
Numerical List of Parts.....	19
Spool Holders.....	18
Table Belt Hole Guard (For Table No. 29738).....	18

## LIST OF PARTS COMPLETE FOR

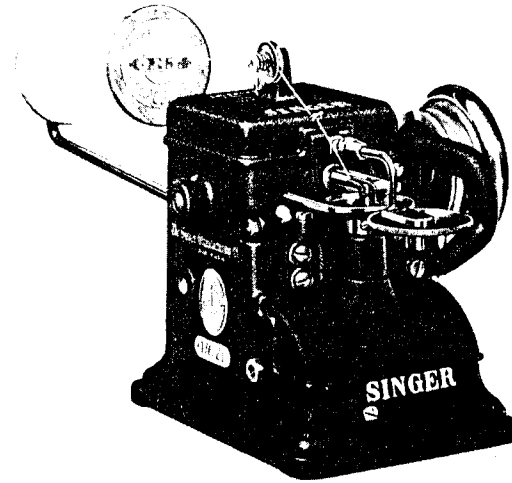

### MACHINE No. 176-21

For Light and Medium Fur Work. Length of stitch 8 to 36 to the inch. Discs have  $\frac{1}{8}$  inch toothed feed surface for regular work and  $\frac{1}{32}$  inch for ermine and mink. Horizontal needle bar, stroke 1 inch. Speed 2400 R. P. M.

No.	Plate	Name
176237	22651	Balance Wheel, 2 1/8 in. diam., pulley, with 435C.....
435C	22651	Balance Wheel Set Screw.....
176238	22651	" " Shaft.....
176239	22651	" " " Bushing (left).....
176240	22651	" " " " " Oil Pad (felt).....
140225C	22651	Balance Wheel Shaft Bushing (left) Set Screw.....
176241	22651	Balance Wheel Shaft Bushing (right).....
176242	22651	" " " " " Oil Pad (felt).....
140225C	22651	Balance Wheel Shaft Bushing (right) Set Screw.....

No.	Plate	Name
176005	22651	Balance Wheel Shaft Counterbalance.....
160E	22651	" " " " " Screw
176006	22651	" " Washer (felt).....
176007	22651	Feed Connection.....
176243	-----	" " 176007 with 176244.....
140079C	22651	" " Hinge Screw.....
176244	22651	" Eccentric with two 1036C.....
1036C	22651	" " Set Screw.....
176245	22653	" Lever.....
176246	-----	" " 176245 with 51663J, 176077 and 176290.....
176011	22653	Feeding Disc (back) with two 889C (7/64 in. wide feeding surface) for regu- lar work.....
176383	-----	Feeding Disc (back) with two 889C (.025 in. wide feeding surface) for Ermine and Mink and extra fine Ermine and Mink.....
Note: No. 176011 is regularly furnished with this Machine.		
889C	22653	Feeding Disc (back) Set Screw.....
176012	22653	" " " Shaft.....
176249	22653	" " " Spacing Collar with two 50150C.....
50150C	22653	Feeding Disc (back) Shaft Spacing Collar Set Screw.....
176014	22653	Feeding Disc (back) Worm Gear with two 889C.....
889C	22653	Feeding Disc (back) Worm Gear Set Screw.
176016	22653	" " " Wheel Driver...
176017	22653	" " " " " " "
460C	22653	Collar with 460C.....
176018	22653	Feeding Disc (back) Worm Wheel Driver Collar Set Screw.....
176019	22653	Feeding Disc (back) Worm Wheel Driver Pressure Spring.....
140181C	22653	Feeding Disc (back) Worm Wheel Driver Screw Stud.....
176021	22653	Feeding Disc (back) Worm Wheel Driver Wearing Screw Stud.....
1650C	22653	Feeding Disc (back) Worm Wheel Driver Wearing Screw Stud Nut.....
176099	22653	Feeding Disc (back) Worm Wheel Shaft with Worm Wheel and Pin.....
176226	22653	Feeding Disc (back) Worm Wheel Shaft 176099 with 1650C, 176016, 176017 to 176019 and 176021.....
577C	22653	Feeding Disc (back) Worm Wheel Shaft Screw Center.....

No.	Plate	Name
176024	-----	Feeding Disc (back) Worm Wheel Shaft Screw Center 577C with 51661K.....
51661K	22653	Feeding Disc (back) Worm Wheel Shaft Screw Center Nut.....
176025	22653	Feeding Disc (back) Worm Wheel Stop Dog.
176026	22653	" " " " " " "
440C	22653	Hinge Stud.....
176027	22653	Feeding Disc (back) Worm Wheel Stop Dog Hinge Stud Set Screw.....
176028	22653	Feeding Disc (back) Worm Wheel Stop Dog Spring.....
176384	-----	Feeding Disc (front) (7/64 in. wide feeding surface) for regular work...
176221	22653	Feeding Disc (front) (.025 in. wide feeding surface) for Ermine and Mink and extra fine Ermine and Mink.....
176385	-----	Feeding Disc (front) 176028 with 50128F, 176037, 176287 and twelve 176038, for regular work.....
Note: No. 176221 is regularly furnished with this Machine.		
176030	22655	Feeding Disc (front) Arm with 1396C (lower and upper) Shaft and Pins....
176031	22653	Feeding Disc (front) Arm Bell Crank....
176257	22653	" " " " " " Shaft
1149C	22653	" " " " " " "
176033	22653	Set Screw.....
140087E	22653	Feeding Disc (front) Arm Pressure Spring " " " " " " "
1714E	22653	Screw.....
176037	22653	Feeding Disc (front) Arm Pressure Spring Screw Nut.....
1396C	22655	Feeding Disc (front) Bearing Screw Stud. " " " " " " "
176038	22653	Clamping Screw.....
*176258	-----	Feeding Disc (front) Roller.....
176259	22655	Head of Machine with 15404, 176261 and two each 15405 and 176009.....
176260	22655	Head of Machine Front Cover.....
176261	22651	" " " " " Lock Stud...
176338	22655	" " " Oil Wick for oiling Looper Driving Shaft Frame Front Bearing.....
58549	22655	Head of Machine Top Cover with 58549 and two 176045.....
		Head of Machine Top Cover Oil Tube with 52045 (for oiling Needle Bar Eccen- tric).....

No.	Plate	Name
52045	22655	Head of Machine Top Cover Oil Tube Packing (cotton).....
176009	22655	Head of Machine Top Cover Steady Pin ...
176045	22655	" " " " " Thread Eyelet.
176398	22653	Looper.....
176368	22651	" Clamping Nut.....
176262	22651	" Driving Eccentric.....
176263	22651	" " " Position Pin...
898E	22651	" " " Screw.....
176264	22651	" " " Sleeve.....
176336	-----	" " " " 176264 with 176262.....
176265	22651	Looper Driving Eccentric Sleeve Position Plate.....
1329E	22651	Looper Driving Eccentric Sleeve Position Plate Screw.....
176360	22651	Looper Driving Shaft.....
176266	22651	" " " Frame with 176265 and two each 1329E and 176306.....
176362	-----	Looper Driving Shaft Frame 176266 with 176336, 176360, 176361 and 176368...
176363	-----	Looper Driving Shaft Frame 176362 with 176271.....
176269	22652	Looper Driving Shaft Frame Crank with 42639.....
176270	-----	Looper Driving Shaft Frame Crank 176269 with 602J and 176274.....
176271	-----	Looper Driving Shaft Frame Crank 176270 with 38635, 51669J and 176273.....
176273	22651	Looper Driving Shaft Frame Crank Hinge Bracket Holder complete, Nos. 127848 and 140227J.....
140227J	22651	Looper Driving Shaft Frame Crank Hinge Bracket Holder Screw.....
127848	22651	Looper Driving Shaft Frame Crank Hinge Bracket Oil Cup.....
140227J	22651	Looper Driving Shaft Frame Crank Hinge Bracket Screw.....
51669J	22651	Looper Driving Shaft Frame Crank Nut....
38635	22651	" " " " " " Wash- er.....
176274	22651	Looper Driving Shaft Frame Crank Wearing Sleeve (.3125 in. diam.).....
176275	22651	Looper Driving Shaft Frame Crank Wearing Sleeve (.313 in. diam.).....
176276	22651	Looper Driving Shaft Frame Crank Wearing Sleeve (.3135 in. diam.).....
176277	22651	Looper Driving Shaft Frame Crank Wearing Sleeve (.314 in. diam.).....
176278	22651	Looper Driving Shaft Frame Crank Wearing Sleeve (.3145 in. diam.).....

No.	Plate	Name
176279	22651	Looper Driving Shaft Frame Crank Wearing Sleeve (.315 in. diam.).....
Note: Nos. 176275 to 176279 are to be furnished for repairs only.		
602J	22651	Looper Driving Shaft Frame Crank Wearing Sleeve Cap Screw.....
42639	22651	Looper Driving Shaft Frame Crank Wearing Sleeve Position Pin.....
176057	22651	Looper Driving Shaft Frame Hinge Screw Stud.....
51669J	22651	Looper Driving Shaft Frame Hinge Screw Stud Nut.....
176306	-----	Looper Driving Shaft Frame Oil Wick for oiling Looper Driving Eccentric.....
176280	22651	Looper Oscillating Cam with 176263 and two 140183C.....
176282	-----	Looper Oscillating Cam 176280 with 176005 and two 160E.....
140183C	22651	Looper Oscillating Cam Set Screw.....
176361	22651	" " Crank with 175E and two 50379C.....
176062	22651	Looper Oscillating Crank Ball.....
176234	-----	" " " " 176062 with 176340.....
176340	22651	Looper Oscillating Crank Ball Stud.....
175E	22651	" " " " Clamp- ing Screw.....
50379C	22651	Looper Oscillating Crank Set Screw.....
176065	22651	Needle Bar with 176075.....
176066	-----	Needle Bar complete, Nos. 140082F, 140083F, 140084F, 176065, 176070, 176071, 176073 and 176074.....
176067	22651	Needle Bar Bushing with 176101.....
51662C	22651	" " " Lock Nut.....
176101	22651	" " " Steady Pin.....
176284	22651	" " Connection with two 185E.....
185E	22651	" " Clamping Screw....
176285	22651	" " Guide Rod.....
624C	22651	" " " " Set Screw.....
176286	22651	Needle Bar Eccentric with two 1036C....
1036C	22651	" " " Set Screw.....
176070	22651	" " Thread Guide.....
140082F	22651	" " " Screw.....
140083F	22651	" " " Nipper Screw.....
176071	22651	" " " " Bushing..
176072	22651	" " " " Slide Rod.....
50421C	22651	" " " " " Set Screw.....
176073	22651	Needle Bar Thread Nipper Spring.....

No.	Plate	Name
176074	22651	Needle Clamp.....
140084F	22651	" " Screw.....
176075	22651	" " Steady Pin.....
176287	22653	" Guide with 51229E, for regular work.....
176288	-----	Needle Guide with 51229E, for Ermine and Mink.....
51229E	22653	Needle Guide Oil Hole Plug Screw.....
50128F	22653	" " Screw.....
176077	22653	Stitch Indicator.....
176289	22653	" Regulating Screw Stud.....
176290	-----	" " " " 176289 with 51669J, 176291 and 176292.....
51669J	22653	Stitch Regulating Screw Stud Nut.....
176291	22653	" " " " Slide Block
51663J	22653	" " " " Thumb Nut..
176292	22653	" " " " Washer.....
2102	22655	Tension Disc.....
1560C	22655	" Regulating Thumb Nut.....
633C	22655	" Screw Stud.....
58592	-----	" " " 633C with 1560C.....
176084	22655	" Spring.....
176085	-----	Tension complete, Nos. 58592, 176084 and two 2102.....
176086	22653	Work Guide.....
440C	22653	" " Set Screw.....
*15404	-----	Trade Mark.....
15405	-----	" " Rivet.....

## LIST OF PARTS COMPLETE

FOR

## MACHINE No. 176-22

For Medium Heavy Fur Work. Also used for closing and sleeve operations. Length of stitch 8 to 36 to the inch. Discs have 1/8 inch toothed feed surface. Horizontal needle bar, stroke 1 1/8 inches. Speed 2000 R. P. M.

No.	Plate	Name
176237	22652	Balance Wheel, 2 1/8 in. diam., pulley, with 435C.....
435C	22652	Balance Wheel Set Screw.....
176238	22652	" " Shaft.....
176239	22652	" " " Bushing (left).....
176240	22652	" " " " Oil Pad (felt).....
140225C	22652	Balance Wheel Shaft Bushing (left) Set Screw.....
176241	22652	Balance Wheel Shaft Bushing (right).....
176242	22652	" " " " " Oil Pad (felt).....
140225C	22652	Balance Wheel Shaft Bushing (right) Set Screw.....
176005	22652	Balance Wheel Shaft Counterbalance.....
160E	22652	" " " " Screw
176006	22652	" " Washer (felt).....
176007	22652	Feed Connection.....
176243	-----	" " 176007 with 176244.....
140079C	22652	" " Hinge Screw.....
176244	22652	" Eccentric with two 1036C.....
1036C	22652	" " Set Screw.....
176245	22654	" Lever.....
176246	-----	" " 176245 with 51663J, 176077 and 176290.....
176011	22654	Feeding Disc (back) with two 889C (7/64 in. wide feeding surface).....
889C	22654	Feeding Disc (back) Set Screw.....
176012	22654	" " " Shaft.....
176249	22654	" " " " Spacing Collar with two 50150C.....
50150C	22654	Feeding Disc (back) Shaft Spacing Collar Set Screw.....
176014	22654	Feeding Disc (back) Worm Gear with two 889C.....

No.	Plate	Name
889C	22654	Feeding Disc (back) Worm Gear Set Screw.
176016	22654	" " " " Wheel Driver...
176017	22654	" " " " " " "
		Collar with 460C.....
460C	22654	Feeding Disc (back) Worm Wheel Driver Collar Set Screw.....
176018	22654	Feeding Disc (back) Worm Wheel Driver Pressure Spring.....
176019	22654	Feeding Disc (back) Worm Wheel Driver Pressure Spring Stud.....
140181C	22654	Feeding Disc (back) Worm Wheel Driver Screw Stud.....
176021	22654	Feeding Disc (back) Worm Wheel Driver Wearing Screw Stud.....
1650C	22654	Feeding Disc (back) Worm Wheel Driver Wearing Screw Stud Nut.....
176099	22654	Feeding Disc (back) Worm Wheel Shaft with Worm Wheel and Pin.....
176226	22654	Feeding Disc (back) Worm Wheel Shaft with 1650C, 176016, 176017 to 176019 and 176021.....
577C	22654	Feeding Disc (back) Worm Wheel Shaft Screw Center.....
176024	-----	Feeding Disc (back) Worm Wheel Shaft Screw Center 577C with 51661K.....
51661K	22654	Feeding Disc (back) Worm Wheel Shaft Screw Center Nut.....
176025	22654	Feeding Disc (back) Worm Wheel Stop Dog.
176026	22654	" " " " " " " "
		Hinge Stud.....
440C	22654	Feeding Disc (back) Worm Wheel Stop Dog Hinge Stud Set Screw.....
176027	22654	Feeding Disc (back) Worm Wheel Stop Dog Spring.....
176028	22654	Feeding Disc (front) 7/64 in. wide feed- ing surface.....
176223	22654	Feeding Disc (front) 176028 with 50128F, 176037, 176304 and twelve 176038....
176030	22655	Feeding Disc (front) Arm with 1396C (lower and upper) Shaft and Pins....
176031	22654	Feeding Disc (front) Arm Bell Crank....
176257	22654	" " " " " " Shaft
1149C	22654	" " " " " " "
		Set Screw.....
176033	22654	Feeding Disc (front) Arm Pressure Spring
140087E	22654	" " " " " " "
		Screw.....
1714E	22654	Feeding Disc (front) Arm Pressure Spring Screw Nut.....
176037	22654	Feeding Disc (front) Bearing Screw Stud.

No.	Plate	Name
1396C	22655	Feeding Disc (front) Bearing Screw Stud Clamping Screw.....
176038	22654	Feeding Disc (front) Roller.....
*176294	-----	Head of Machine with 15404, 176261 and two each 15405 and 176009.....
176259	22655	Head of Machine Front Cover.....
176260	22655	" " " " " Lock Stud...
176261	22652	" " " Oil Wick for oiling Loop- er Driving Shaft Frame Front Bearing
176338	22655	Head of Machine Top Cover.....
58549	22655	" " " " " Oil Tube with 52045 (for oiling Needle Bar Eccen- tric).....
52045	22655	Head of Machine Top Cover Oil Tube Pack- ing (cotton).....
176009	22655	Head of Machine Top Cover Steady Pin....
176045	22655	" " " " " Thread Eyelet.
176209	22654	Looper.....
176368	22652	" Clamping Nut.....
176262	22652	" Driving Eccentric.....
176263	22652	" " " Position Pin...
896E	22652	" " " Screw.....
176264	22652	" " " Sleeve.....
176336	-----	" " " " 176264 with 176262.....
176265	22652	Looper Driving Eccentric Sleeve Position Plate.....
1329E	22652	Looper Driving Eccentric Sleeve Position Plate Screw.....
176360	22652	Looper Driving Shaft.....
176295	22652	" " " Frame with 176265 and two each 1329E and 176306.....
176364	-----	Looper Driving Shaft Frame 176295 with 176336, 176360, 176361 and 176368...
176365	-----	Looper Driving Shaft Frame 176364 with 176271 and 176298.....
176269	22652	Looper Driving Shaft Frame Crank (back) with 42639.....
176270	-----	Looper Driving Shaft Frame Crank (back) 176269 with 602J and 176274.....
176298	-----	Looper Driving Shaft Frame Crank (back) 176270 with 38635, 51669J and 176299
176299	22652	Looper Driving Shaft Frame Crank (back) Hinge Bracket Holder complete, Nos. 127848 and 140227J.....
140227J	22652	Looper Driving Shaft Frame Crank (back) Hinge Bracket Holder Screw.....
127848	22652	Looper Driving Shaft Frame Crank (back) Hinge Bracket Oil Cup.....
140227J	22652	Looper Driving Shaft Frame Crank (back) Hinge Bracket Screw.....

No.	Plate	Name
176269	22652	Looper Driving Shaft Frame Crank (front) with 42639.....
176270	-----	Looper Driving Shaft Frame Crank (front) 176269 with 602J and 176274.....
176271	-----	Looper Driving Shaft Frame Crank (front) 176270 with 38635, 51669J and 176273
176273	22652	Looper Driving Shaft Frame Crank (front) Hinge Bracket Holder complete, Nos. 127848 and 140227J.....
140227J	22652	Looper Driving Shaft Frame Crank (front) Hinge Bracket Holder Screw.....
127848	22652	Looper Driving Shaft Frame Crank (front) Hinge Bracket Oil Cup.....
140227J	22652	Looper Driving Shaft Frame Crank (front) Hinge Bracket Screw.....
51669J	22652	Looper Driving Shaft Frame Crank Nut....
38635	22652	" " " " " " Washer.....
176274	22652	Looper Driving Shaft Frame Crank Wearing Sleeve (.3125 in. diam.).....
176275	22652	Looper Driving Shaft Frame Crank Wearing Sleeve (.313 in. diam.).....
176276	22652	Looper Driving Shaft Frame Crank Wearing Sleeve (.3135 in. diam.).....
176277	22652	Looper Driving Shaft Frame Crank Wearing Sleeve (.314 in. diam.).....
176278	22652	Looper Driving Shaft Frame Crank Wearing Sleeve (.3145 in. diam.).....
176279	22652	Looper Driving Shaft Frame Crank Wearing Sleeve (.315 in. diam.).....
Note: Nos. 176275 to 176279 are to be furnished for repairs only.		
602J	22652	Looper Driving Shaft Frame Crank Wearing Sleeve Cap Screw.....
42639	22652	Looper Driving Shaft Frame Crank Wearing Sleeve Position Pin.....
176306	-----	Looper Driving Shaft Frame Oil Wick for oiling Looper Driving Eccentric.....
176300	22652	Looper Oscillating Cam with 176263 and two 140183C.....
176302	-----	Looper Oscillating Cam 176300 with 176005 and two 160E.....
140183C	22652	Looper Oscillating Cam Set Screw.....
176361	22652	" " " " Crank with 175E and two 50379C.....
176062	22652	Looper Oscillating Crank Ball.....
176234	-----	" " " " 176062 with 176340.....
176340	22652	Looper Oscillating Crank Ball Stud.....
175E	22652	" " " " Clamp- ing Screw.....

No.	Plate	Name
50379C	22652	Looper Oscillating Crank Set Screw.....
176216	22652	Needle Bar with 176075.....
176217	-----	Needle Bar complete, Nos. 140082F, 140083F, 140084F, 176070, 176071, 176073, 176074 and 176216.....
176067	22652	Needle Bar Bushing with 176101.....
51662C	22652	" " " Lock Nut.....
176101	22652	" " " Steady Pin.....
176284	22652	" " Connection with two 185E.....
185E	22652	" " " Clamping Screw....
176285	22652	" " " Guide Rod.....
624C	22652	" " " " " Set Screw.....
176303	22652	Needle Bar Eccentric with two 1036C....
1036C	22652	" " " Set Screw.....
176070	22652	" " Thread Guide.....
140082F	22652	" " " " Screw.....
140083F	22652	" " " Nipper Screw.....
176071	22652	" " " " " Bushing..
176213	22652	" " " " Slide Rod.....
50421C	22652	" " " " " Set Screw.....
176073	22652	Needle Bar Thread Nipper Spring.....
176074	22652	" Clamp.....
140084F	22652	" " Screw.....
176075	22652	" " Steady Pin.....
176304	22654	" Guide with 51229E.....
51229E	22654	" " Oil Hole Plug Screw.....
50128F	22654	" " Screw.....
176077	22654	Stitch Indicator.....
176289	22654	" Regulating Screw Stud.....
176290	-----	" " " " 176289 with 51669J, 176291 and 176292.....
51669J	22654	Stitch Regulating Screw Stud.....
176291	22654	" " " " Slide Block
51663J	22654	" " " " Thumb Nut..
176292	22654	" " " " Washer.....
2102	22655	Tension Disc.....
1560C	22655	" Regulating Thumb Nut.....
633C	22655	" Screw Stud.....
58592	-----	" " " 633C with 1560C.....
176084	22655	" Spring.....
176085	-----	Tension complete, Nos. 58592, 176084 and two 2102.....
176086	22654	Work Guide.....
440C	22654	" " Set Screw.....
*15404	-----	Trade Mark.....
15405	-----	" " Rivet.....



## ACCESSORIES

No.	Plate	Name
176203	----	Belt, 1/4 in. round, 36 in. long with 176088.....
176088	22657	Belt Hook for 176203.....
120342	22657	Oiler (copper plated) with 120343.....
120343	22657	" Spout, 3 1/2 in. long.....
26026	22657	Screw Driver.....
176089	22657	Tweezers.....
176369	22657	Wrench for 176368.....

## MACHINE BASES

No.	Plate	Name
176358	22656	Machine Base with four wood screws 1 in. No. 10 F.H. (no provision for Oil Drain Cock).....
176090	22656	Machine Base with four wood screws 1 in. No. 10 F.H. (with provision for Oil Drain Cock).....
Note: No. 176358 is regularly furnished with these Machines unless otherwise specified on order.		
49123	22656	Machine Base Oil Pipe.....
49124	22656	" " " " Drain Cock.....
145E	22656	" Screw.....
4718	22656	" " Washer (felt).....

FEEDING DISC OPENING  
AND  
STARTING PARTS

No.	Plate	Name
175216	22657	Feeding Disc Opening Treadle.....
175217	22657	" " " " Hinge Pin..
175218	22657	" " " " Stand.....
175219	22657	Feeding Disc Opening Treadle complete, Nos. 175216 to 175218 and two wood screws 1 in. No. 14 F.H.....

No.	Plate	Name
46848	22657	Feeding Disc Opening Treadle Pitman Rod (lower).....
46848	22657	Feeding Disc Opening Treadle Pitman Rod (upper).....
46849	22657	Feeding Disc Opening Treadle Pitman Rod (upper) Connecting Lever.....
46850	22657	Feeding Disc Opening Treadle Pitman Rod (upper) Connecting Lever Bracket....
24665	22657	Feeding Disc Opening Treadle Pitman Rod (upper) Connecting Lever Hinge Pin..
46851	22657	Feeding Disc Opening Treadle Pitman Rod (upper) Connecting Lever complete, Nos. 24665, 46849, 46850 and two wood screws 3/4 in. No. 10 R.H.M.F.....
176318	22657	Feeding Disc Opening Treadle Pitman Rod (upper) Connecting Lever Chain (seven links) with two 39576.....
39576	22657	Feeding Disc Opening Treadle Pitman Rod (upper) Connecting Lever Chain Hook for 176318.....
80223	22657	Feeding Disc Opening Treadle Pitman Rod Clamp with 361C.....
361C	22657	Feeding Disc Opening Treadle Pitman Rod Clamp Set Screw.....
123183	22657	Feeding Disc Opening Treadle Pitman Rod Cotter Pin.....
176091	22657	Feeding Disc Opening Treadle Pitman Rod complete, Nos. 80223 and two each 46848 and 123183.....
175216	22657	Starting Treadle.....
175217	22657	" " Hinge Pin.....
175218	22657	" " Stand.....
175219	22657	Starting Lever Treadle complete, Nos. 175216 to 175218 and two wood screws 1 in. No. 14 F.H.....
46848	22657	Starting Treadle Pitman Rod (lower)....
46848	22657	" " " " (upper)....
80223	22657	" " " " Clamp with 361C.....
361C	22657	Starting Treadle Pitman Rod Clamp Set Screw.....
123183	22657	Starting Treadle Pitman Rod Cotter Pin..
176091	22657	Starting Treadle Pitman Rod complete, Nos. 80223 and two each 46848 and 123183.....

## SPOOL HOLDERS

## SPOOL HOLDER

(FOR 12000 YARD SPOOLS)

No.	Plate	Name
176305	22657	Spool Holder with two 919R.....
919R	22657	" " Screw.....

## SPOOL HOLDER

(FOR SPOOLS CONTAINING 300 YARDS OR LESS OF THREAD)

No.	Plate	Name
176386	22658	Spool Holder Bracket.....
919R	22658	" " " Screw.....
34460	22658	" " Spool Pin.....
34402	-----	" " " " Disc.....
34403	22658	" " " " " 34402 with 557A.....
557A	22658	Spool Holder Spool Pin Disc Thumb Screw.
1550J	22658	" " " " Nut.....
176387	22658	Spool Holder complete, Nos. 1550J, 34403, 34460, 176386 and two 919R.....

## TABLE BELT HOLE GUARD

FOR TABLE No. 29738

No.	Plate	Name
152051	22657	Table Belt Hole Guard with two wood screws 7/8 in. No. 10 F.H.....

## NUMERICAL LIST OF PARTS

## NUMERICAL LIST OF PARTS

No.	Plate	Name
145E	22656	Machine Screw.....
160E	22651	Balance Wheel Shaft Counterbalance Screw for 176282 and 176302.....
175E	22651	Looper Oscillating Crank Ball Stud Clamping Screw for 176361.....
185E	22651	Needle Bar Connection Clamping Screw for 176284.....
361C	22657	Feeding Disc Opening Treadle Pitman Rod Clamp Set Screw for 80223.....
361C	22657	Starting Treadle Pitman Rod Clamp Set Screw for 80223.....
435C	22651	Balance Wheel Set Screw for 176237.....
440C	22653	Feeding Disc (back) Worm Wheel Stop Dog Hinge Stud Set Screw.....
440C	22653	Work Guide Set Screw.....
460C	22653	Feeding Disc (back) Worm Wheel Driver Collar Set Screw for 176017.....
557A	22658	Spool Holder Spool Pin Disc Thumb Screw for 34403.....
577C	22653	Feeding Disc (back) Worm Wheel Shaft Screw Center for 176024.....
602J	22651	Looper Driving Shaft Frame Crank Wearing Sleeve Cap Screw for 176270.....
624C	22651	Needle Bar Connection Guide Rod Set Screw.....
633C	22655	Tension Screw Stud for 58592.....
889C	22653	Feeding Disc (back) Set Screw for 176383
889C	22653	" " " Worm Gear Set Screw for 176014.....
898E	22651	Looper Driving Eccentric Screw.....
919R	22657	Spool Holder Screw for 176305.....
919R	22658	" " Bracket Screw for 176387...
1036C	22651	Feed Eccentric Set Screw for 176244.....
1036C	22651	Needle Bar Eccentric Set Screw for 176286 and 176303.....
1149C	22653	Feeding Disc (front) Arm Bell Crank Shaft Set Screw.....
1329E	22651	Looper Driving Eccentric Sleeve Position Plate Screw for 176266 and 176295...
1396C	22655	Feeding Disc (front) Bearing Screw Stud Clamping Screw for 176030.....
1550J	22658	Spool Holder Spool Pin Nut for 176387...
1560C	22655	Tension Regulating Thumb Nut for 58592..
1650C	22653	Feeding Disc (back) Worm Wheel Driver Wearing Screw Stud Nut for 176226...
1714E	22653	Feeding Disc (front) Arm Pressure Spring Screw Nut.....

No.	Plate	Name
2102	22655	Tension Disc for 176085.....
4718	22656	Machine Screw Washer (felt).....
*15404	-----	Trade Mark for 176258 and 176294.....
15405	-----	" " Rivet for 176258 and 176294..
24665	22657	Feeding Disc Opening Treadle Pitman Rod (upper) Connecting Lever Hinge Pin for 46851.....
26026	22657	Screw Driver (Accessories).....
34402	-----	Spool Holder Spool Pin Disc for 34403...
34403	22658	" " " " " 34402 with 557A, for 176387.....
34460	22658	Spool Holder Spool Pin for 176387.....
38635	22651	Looper Driving Shaft Frame Crank Nut Washer for 176271 and 176298.....
39576	22657	Feeding Disc Opening Treadle Pitman Rod (upper) Connecting Lever Chain Hook for 176318.....
42639	22651	Looper Driving Shaft Frame Crank Wearing Sleeve Position Pin for 176269.....
46848	22657	Feeding Disc Opening Treadle Pitman Rod (lower) for 176091.....
46848	22657	Feeding Disc Opening Treadle Pitman Rod (upper) for 176091.....
46848	22657	Starting Treadle Pitman Rod (lower) for 176091.....
46848	22657	Starting Treadle Pitman Rod (upper) for 176091.....
46849	22657	Feeding Disc Opening Treadle Pitman Rod (upper) Connecting Lever for 46851..
46850	22657	Feeding Disc Opening Treadle Pitman Rod (upper) Connecting Lever Bracket for 46851.....
46851	22657	Feeding Disc Opening Treadle Pitman Rod (upper) Connecting Lever complete, Nos. 24665,46849,46850 and two wood screws 3/4 in. No. 10 R.H.M.F.....
49123	22656	Machine Base Oil Pipe.....
49124	22656	" " " " Drain Cock.....
50128F	22653	Needle Guide Screw for 176221,176223 and 176385.....
50150C	22653	Feeding Disc (back) Shaft Spacing Collar Set Screw for 176249.....
50379C	22651	Looper Oscillating Crank Set Screw for 176361.....
50421C	22651	Needle Bar Thread Nipper Slide Rod Set Screw.....
51229E	22653	Needle Guide Oil Hole Plug Screw for 176287, 176288 and 176304.....
51661K	22653	Feeding Disc (back) Worm Wheel Shaft Screw Center Nut for 176024.....
51662C	22651	Needle Bar Bushing Lock Nut.....

No.	Plate	Name
51663J	22653	Stitch Regulating Screw Stud Thumb Nut for 176246.....
51669J	22651	Looper Driving Shaft Frame Crank Nut for 176271 and 176298.....
51669J	22651	Looper Driving Shaft Frame Hinge Screw Stud Nut.....
51669J	22653	Stitch Regulating Screw Stud Nut for 176290.....
52045	22655	Head of Machine Top Cover Oil Tube Pack- ing (cotton) for 58549.....
58549	22655	Head of Machine Top Cover Oil Tube with 52045 (for oiling Needle Bar Eccen- tric) for 176338.....
58592	-----	Tension Screw Stud 633C with 1560C, for 176085.....
80223	22657	Feeding Disc Opening Treadle Pitman Rod Clamp with 361C, for 176091.....
80223	22657	Starting Treadle Pitman Rod Clamp with 361C, for 176091.....
120342	22657	Oiler (copper plated) with 120343 (Ac- cessories).....
120343	22657	Oiler Spout, 3 1/2 in. long, for 120342 (Accessories).....
123183	22657	Feeding Disc Opening Treadle Pitman Rod Cotter Pin for 176091.....
123183	22657	Starting Treadle Pitman Rod Cotter Pin for 176091.....
127848	22651	Looper Driving Shaft Frame Crank Hinge Bracket Oil Cup for 176273.....
127848	22652	Looper Driving Shaft Frame Crank (back) Hinge Bracket Oil Cup for 176299....
127848	22652	Looper Driving Shaft Frame Crank (front) Hinge Bracket Oil Cup for 176273....
140079C	22651	Feed Connection Hinge Screw.....
140082F	22651	Needle Bar Thread Guide Screw for 176066 and 176217.....
140083F	22651	Needle Bar Thread Nipper Screw for 176066 and 176217.....
140084F	22651	Needle Clamp Screw for 176066 and 176217
140087E	22653	Feeding Disc (front) Arm Pressure Spring Screw.....
140181C	22653	Feeding Disc (back) Worm Wheel Driver Screw Stud.....
140183C	22651	Looper Oscillating Cam Set Screw for 176280 and 176300.....
140225C	22651	Balance Wheel Shaft Bushing (left) Set Screw.....
140225C	22651	Balance Wheel Shaft Bushing (right) Set Screw.....
140227J	22651	Looper Driving Shaft Frame Crank Hinge Bracket Holder Screw.....

No.	Plate	Name
140227J	22651	Looper Driving Shaft Frame Crank Hinge Bracket Screw for 176273.....
140227J	22652	Looper Driving Shaft Frame Crank (back) Hinge Bracket Holder Screw for 176299.....
140227J	22652	Looper Driving Shaft Frame Crank (back) Hinge Bracket Screw for 176-22 Machine.....
140227J	22652	Looper Driving Shaft Frame Crank (front) Hinge Bracket Screw.....
140227J	22652	Looper Driving Shaft Frame Crank (front) Hinge Bracket Holder Screw for 176273.....
152051	22657	Table Belt Hole Guard with two wood screws 7/8 in. No. 10 F.H.....
175216	22657	Feeding Disc Opening Treadle for 175219.
175216	22657	Starting Treadle for 175219.....
175217	22657	Feeding Disc Opening Treadle Hinge Pin for 175219.....
175217	22657	Starting Treadle Hinge Pin for 175219...
175218	22657	Feeding Disc Opening Treadle Stand for 175219.....
175218	22657	Starting Treadle Stand for 175219.....
175219	22657	Feeding Disc Opening Treadle complete, Nos. 176216 to 175218 and two wood screws 1 in. No. 14 F.H.....
175219	22657	Starting Lever Treadle complete, Nos. 175216 to 175218 and two wood screws 1 in. No. 14 F.H.....
176005	22651	Balance Wheel Shaft Counterbalance for 176232 and 176302.....
176006	22651	Balance Wheel Washer (felt).....
176007	22651	Feed Connection for 176243.....
176009	22655	Head of Machine Top Cover Steady Pin for 176258 and 176294.....
176011	22653	Feeding Disc (back) with two 889C (7/64 in. wide feeding surface) for regular work.....
176012	22653	Feeding Disc (back) Shaft.....
176014	22653	" " " Worm Gear with two 889C.....
176016	22653	Feeding Disc (back) Worm Wheel Driver for 176226.....
176017	22653	Feeding Disc (back) Worm Wheel Driver Collar with 460C, for 176226.....
176018	22653	Feeding Disc (back) Worm Wheel Driver Pressure Spring for 176226.....
176019	22653	Feeding Disc (back) Worm Wheel Driver Pressure Spring Stud for 176226.....
176021	22653	Feeding Disc (back) Worm Wheel Driver Wearing Screw Stud for 176226.....

No.	Plate	Name
176024	-----	Feeding Disc (back) Worm Wheel Shaft Screw Center 577C with 51661K.....
176025	22653	Feeding Disc (back) Worm Wheel Stop Dog.
176026	22653	" " " " " " " " Hinge Stud.....
176027	22653	Feeding Disc (back) Worm Wheel Stop Dog Spring.....
176028	22653	Feeding Disc (front) (7/64 in. wide feeding surface) for regular work, for 176221 and 176223.....
176030	22655	Feeding Disc (front) Arm with 1396C (lower and upper) Shaft and Pins....
176031	22653	Feeding Disc (front) Arm Bell Crank....
176033	22653	" " " " Pressure Spring
176037	22653	" " " Bearing Screw Stud for 176221, 176223 and 176385.....
176038	22653	Feeding Disc (front) Roller for 176221, 176223 and 176385.....
176045	22655	Head of Machine Top Cover Thread Eyelet for 176338.....
176057	22651	Looper Driving Shaft Frame Hinge Screw Stud.....
176062	22651	Looper Oscillating Crank Ball for 176234
176065	22651	Needle Bar with 176075, for 176066 ....
176066	-----	Needle Bar complete for 176-21 Machine, Nos. 140082F, 140083F, 140084F, 176065, 176070, 176071, 176073 and 176074.....
176067	22651	Needle Bar Bushing with 176101.....
176070	22651	" " Thread Guide for 176066 and 176217.....
176071	22651	Needle Bar Thread Nipper Screw Bushing for 176066 and 176217.....
176072	22651	Needle Bar Thread Nipper Slide Rod for 176-21 Machine.....
176073	22651	Needle Bar Thread Nipper Spring for 176066 and 176217.....
176074	22651	Needle Clamp for 176066 and 176217.....
176075	22651	" " Steady Pin for 176065 and 176216.....
176077	22653	Stitch Indicator for 176246.....
176084	22655	Tension Spring for 176085.....
176085	-----	Tension complete, Nos. 58592, 176084 and two 2102.....
176086	22653	Work Guide.....
176088	22657	Belt Hook for 176203 (Accessories)....
176089	22657	Tweezers (Accessories).....
176090	22656	Machine Base with four wood screws 1 in. No. 10 F.H. (with provision for Oil Drain Cock).....

## NUMERICAL LIST OF PARTS

No.	Plate	Name
176091	22657	Feeding Disc Opening Treadle Pitman Rod complete, Nos. 80223 and two each 46848 and 123183.....
176091	22657	Starting Treadle Pitman Rod complete, Nos. 80223 and two each 46848 and 123183.....
176099	22653	Feeding Disc (back) Worm Wheel Shaft with Worm Wheel and Pin for 176226..
176101	22651	Needle Bar Bushing Steady Pin for 176067
176203	-----	Belt, 1/4 in. round, 3.6 in. long, with 176088 (Accessories).....
176209	22654	Looper for 176-22 Machine.....
176213	22652	Needle Bar Thread Nipper Slide Rod for 176-22 Machine.....
176216	22652	Needle Bar with 176075, for 176217.....
176217	-----	Needle Bar complete for 176-22 Machine, Nos. 140082F, 140083F, 140084F, 176070, 176071, 176073, 176074 and 176216...
176221	22653	Feeding Disc (front) 176028 with 50128F, 176037, 176287 and twelve 176038, for regular work, for 176-21 Machine....
176223	22654	Feeding Disc (front) 176028 with 50128F, 176037, 176304 and twelve 176038, for 176-22 Machine.....
176226	22653	Feeding Disc (back) Worm Wheel Shaft 176099 with 1650C, 176016, 176017 to 176019 and 176021.....
176234	-----	Looper Oscillating Crank Ball 176062 with 176340.....
176237	22651	Balance Wheel, 2 1/8 in. diam. pulley, with 435C.....
176238	22651	Balance Wheel Shaft.....
176239	22651	" " " Bushing (left).....
176240	22651	" " " " " Oil Pad (felt).....
176241	22651	Balance Wheel Shaft Bushing (right)....
176242	22651	" " " " " Oil Pad (felt).....
176243	-----	Feed Connection 176007 with 176244.....
176244	22651	" Eccentric with two 1036C, for 176243.....
176245	22653	Feed Lever for 176246.....
176246	-----	" " 176245 with 51663J, 176077 and 176290.....
176249	22653	Feeding Disc (back) Shaft Spacing Collar with two 50150C.....
176257	22653	Feeding Disc (front) Arm Bell Crank Shaft.....
*176258	-----	Head of Machine with 15404, 176261 and two each 15406 and 176009, for 176-21 Machine.....

## NUMERICAL LIST OF PARTS

No.	Plate	Name
176259	22655	Head of Machine Front Cover.....
176260	22655	" " " " " Lock Stud...
176261	22651	" " " Oil Wick for oiling Looper Driving Shaft Frame Front Bearing for 176258 and 176294.....
176262	22651	Looper Driving Eccentric for 176336.....
176263	22651	" " " Position Pin for 176280 and 176300.....
176264	22651	Looper Driving Eccentric Sleeve for 176336.....
176265	22651	Looper Driving Eccentric Sleeve Position Plate for 176266 and 176295.....
176266	22651	Looper Driving Shaft Frame with 176265 and two each 1329E and 176306, for 176362, for 176-21 Machine.....
176269	22651	Looper Driving Shaft Frame Crank with 42639, for 176270.....
176269	22652	Looper Driving Shaft Frame Crank (back) with 42639, for 176270.....
176269	22652	Looper Driving Shaft Frame Crank (front) with 42639, for 176270.....
176270	-----	Looper Driving Shaft Frame Crank 176269 with 602J and 176274, for 176271....
176270	-----	Looper Driving Shaft Frame Crank (back) 176269 with 602J and 176274, for 176298.....
176270	-----	Looper Driving Shaft Frame Crank (front) 176269 with 602J and 176274, for 176271.....
176271	-----	Looper Driving Shaft Frame Crank 176270 with 38635, 51669J and 176273, for 176363.....
176271	-----	Looper Driving Shaft Frame Crank (front) 176270 with 38635, 51669J and 176273, for 176365.....
176273	22651	Looper Driving Shaft Frame Crank Hinge Bracket Holder complete for 176271, Nos. 127848 and 140227J.....
176273	22652	Looper Driving Shaft Frame Crank (front) Hinge Bracket Holder complete for 176271, Nos. 127848 and 140227J.....
176274	22651	Looper Driving Shaft Frame Crank Wearing Sleeve (.3125 in. diam.) for 176270.
176275	22651	Looper Driving Shaft Frame Crank Wearing Sleeve (.313 in. diam.).....
176276	22651	Looper Driving Shaft Frame Crank Wearing Sleeve (.3135 in. diam.).....
176277	22651	Looper Driving Shaft Frame Crank Wearing Sleeve (.314 in. diam.).....
176278	22651	Looper Driving Shaft Frame Crank Wearing Sleeve (.3145 in. diam.).....

## NUMERICAL LIST OF PARTS

No.	Plate	Name
176279	22651	Looper Driving Shaft Frame Crank Wearing Sleeve (.315 in. diam.).....
176280	22651	Looper Oscillating Cam with 176263 and two 140183C, for 176282.....
176282	-----	Looper Oscillating Cam 176280 with 176005 and two 160E, for 176-21 Machine.....
176284	22651	Needle Bar Connection with two 185E....
176285	22651	" " " Guide Rod.....
176286	22651	" " Eccentric with two 1036C, for 176-21 Machine.....
176287	22653	Needle Guide with 51229E, for regular work, for 176221.....
176288	-----	Needle Guide with 51229E, for Ermine and Mink, for 176385.....
176289	22653	Stitch Regulating Screw Stud for 176290.
176290	-----	" " " " 176289 with 51669J, 176291 and 176292, for 176246
176291	22653	Stitch Regulating Screw Stud Slide Block for 176290.....
176292	22653	Stitch Regulating Screw Stud Washer for 176290.....
*176294	-----	Head of Machine with 15404, 176261 and two each 15405 and 176009, for 176-22 Machine.....
176295	22652	Looper Driving Shaft Frame with 176265 and two each 1329E and 176306, for 176364.....
176298	-----	Looper Driving Shaft Frame Crank (back) 176270 with 39635, 51669J and 176299, for 176365.....
176299	22652	Looper Driving Shaft Frame Crank (back) Hinge Bracket Holder complete for 176298, Nos. 127848 and 140227J....
176300	22652	Looper Oscillating Cam with 176263 and two 140183C, for 176302.....
176302	-----	Looper Oscillating Cam 176300 with 176005 and two 160E, for 176-22 Machine.....
176303	22652	Needle Bar Eccentric with two 1036C, for 176-22 Machine.....
176304	22654	Needle Guide with 51229E, for 176223....
176305	22657	Spool Holder with two 919R.....
176306	-----	Looper Driving Shaft Frame Oil Wick for oiling Looper Driving Eccentric for 176266 and 176295.....
176318	22657	Feeding Disc Opening Treadle Pitman Rod (upper) Connecting Lever Chain (seven links) with two 39576.....
176336	-----	Looper Driving Eccentric Sleeve 176264.. with 176262, for 176362 and 176364

## NUMERICAL LIST OF PARTS

No.	Plate	Name
176338	22655	Head of Machine Top Cover with 58549 and two 176045.....
176340	22651	Looper Oscillating Crank Ball Stud for 176234.....
176358	22656	Machine Base with four wood screws 1 in. No. 10 F.H. (no provision for Oil Drain Cock).....
176360	22651	Looper Driving Shaft for 176362 and 176364.....
176361	22651	Looper Oscillating Crank with 175E and two 50379C, for 176362 and 176364...
176362	-----	Looper Driving Shaft Frame 176266 with 176336, 176360, 176361 and 176368, for 176363.....
176363	-----	Looper Driving Shaft Frame 176362 with 176271, for 176-21 Machine.....
176364	-----	Looper Driving Shaft Frame 176295 with 176336, 176360, 176361 and 176368, for 176365.....
176365	-----	Looper Driving Shaft Frame 176364 with 176271 and 176298, for 176-21 Machine.....
176368	22651	Looper Clamping Nut for 176362 and 176364.....
176369	22657	Wrench for 176368 (Accessories).....
176383	-----	Feeding Disc (back) with two 889C (.025 in. wide feeding surface) for Ermine and Mink and extra fine Ermine and Mink, for 176-21 Machine.....
176384	-----	Feeding Disc (front) .025 in. wide feeding surface, 176385, for Ermine and Mink and extra fine Ermine and Mink, for 176-21 Machine.....
176385	-----	Feeding Disc (front) 176384 with 50128F, 176037, 176288 and twelve 176038, for Ermine and Mink and extra fine Ermine and Mink, for 176-21 Machine.
176386	22658	Spool Holder Bracket for 176387.....
176387	22658	Spool Holder complete, Nos. 1550J, 34403, 34460, 176386 and two 919R.....
176388	22653	Looper for 176-21 Machine.....







22654 - 1/2

176-22

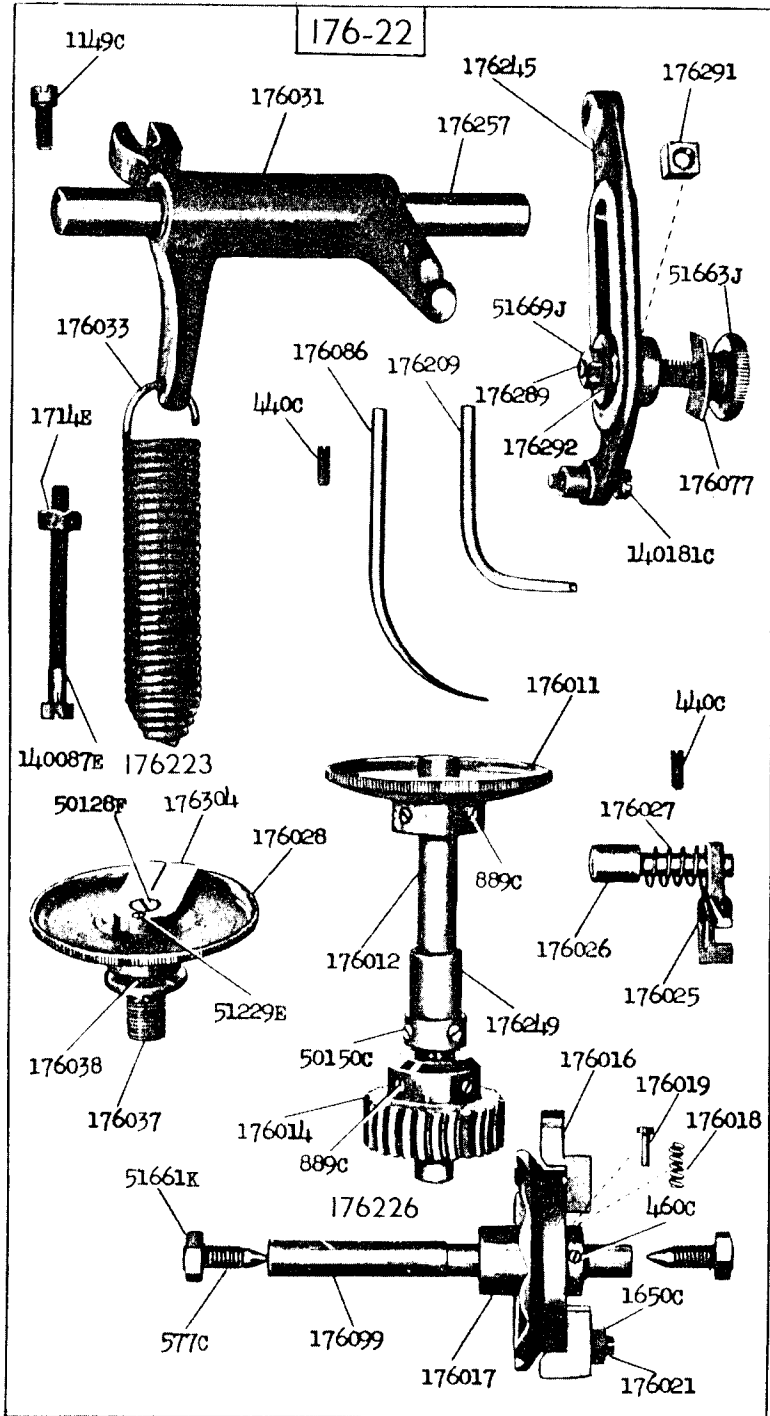

22655 - 1/3

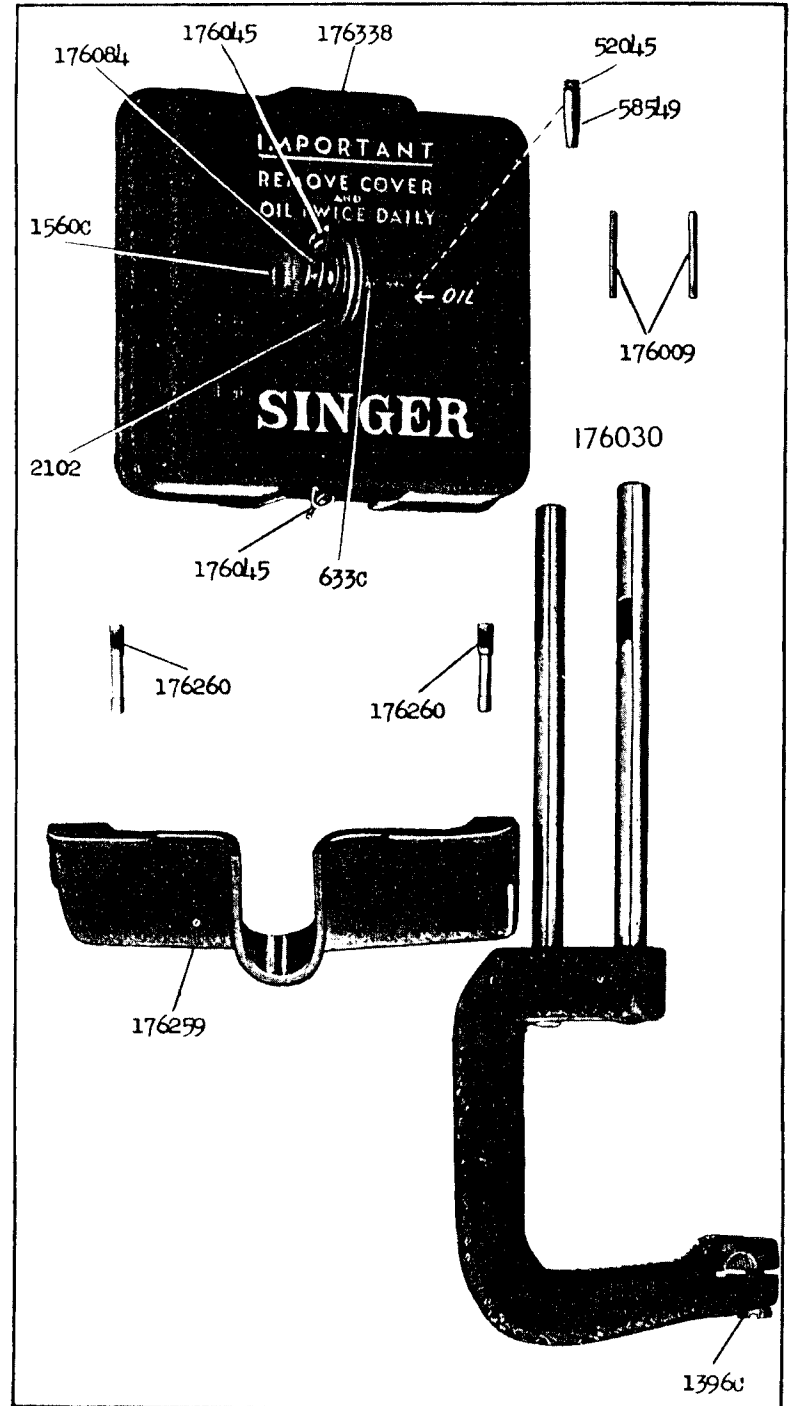

22656 - 1/3

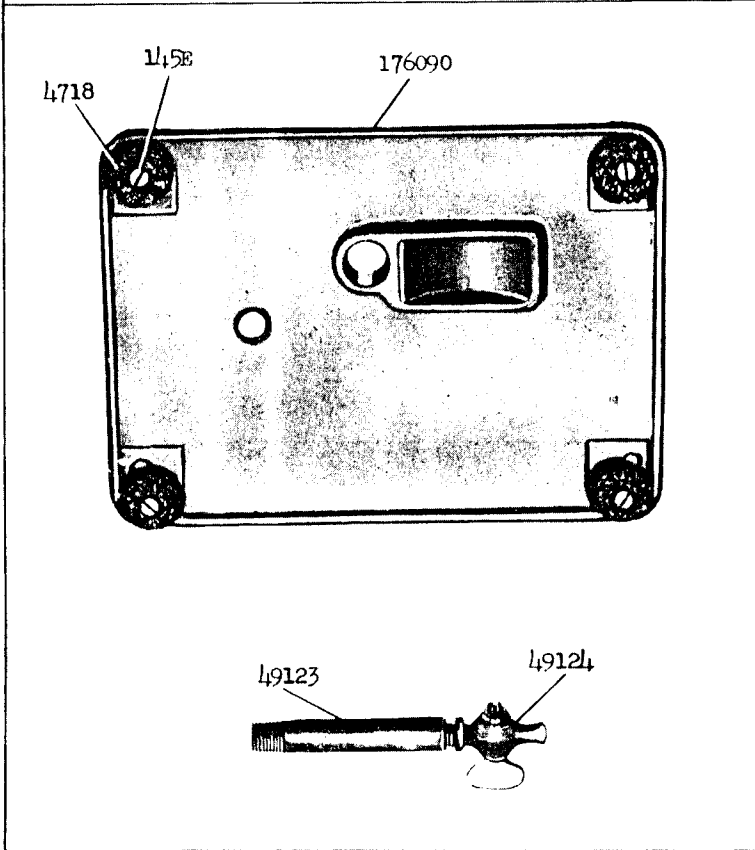
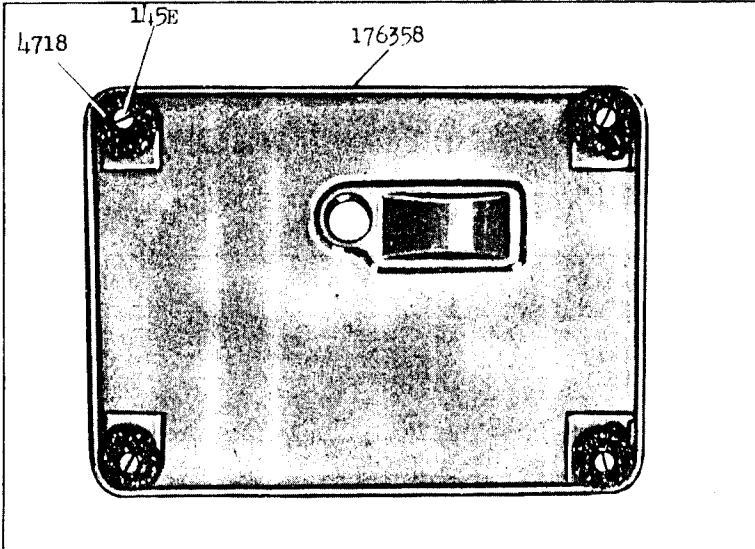

22657 - 1/3

