

Singer 31-15  
Singer 31-16  
Singer 31-19  
Singer 31-20  
Singer 31-22  
Singer 31-24  
Singer 31-27  
Singer 31-32  
Singer 31-34  
Singer 31-35  
Singer 31-37  
Singer 31-39  
Singer 31-42

Form 8733 Revised  
November, 1929  
PRINTED IN U. S. A.

# LIST OF PARTS



## SINGER\*\* MACHINES

**Nos. 31-15, 31-16, 31-19, 31-20, 31-22,  
31-24, 31-27, 31-32, 31-34, 31-35,  
31-37, 31-39 and 31-42**

---

**THE SINGER MANUFACTURING COMPANY**

\*\*A Trade Mark of THE SINGER MANUFACTURING COMPANY



## INDEX—Continued

	PAGE
STAND No. 25255.....	171
“ “ 25265.....	172
“ “ 25279.....	173
“ “ 25284.....	174
STARTING TREADLE PARTS.....	110
STRIP FOLDERS.....	133
THREAD UNWINDERS.....	175
THROAT PLATES.....	153
TRIMMINGS FOR END AND BACK LEAF TABLE.....	174
TUBULAR TRIMMING ATTACHMENT.....	154
TUCKER.....	154
TUCKER (POWER).....	155
“ (LONG ARM).....	156
WELT GUIDE.....	156

**SINGER** Needles should be used  
in **SINGER** Machines  
These Needles and their Containers  
are marked with the  
Company's Trade Mark "SIMANCO.\*\*" 1

Needles in Containers marked  
"FOR SINGER MACHINES"  
are NOT **SINGER** made needles. 2

## INSTRUCTIONS FOR ORDERING

In ordering from this list, use **ONLY** the part **NUMBER** in the **FIRST** Column.

The number stamped on a Sewing Machine Part is in every case the number of the single part only.

Every combination of parts sent out as such has its specific number, which, although not stamped on the parts, must be used when ordering the combination.

Each number always indicates the **SAME PART** in whatever list it appears, or for whatever machine.

The letters after some of the numbers indicate the style of finish only, as follows:

- A-Hardened, Polished, Nickel Plated and Buffed.
- A.A-Buffed and Chromium Plated.
- A.B-Hardened, Polished, Buffed and Chromium Plated.
- A.C-Brown Baking Enamel Finish.
- A.D-Gray Baking Enamel Finish.
- A.E-Hardened, Bright Rumbled and Nickel Plated.
- A.F-Hardened, Bright Rumbled, Nickel Plated, Bright Rumbled and Chromium Plated.
- A.G-Alumilite, Plain.
- A.H-Alumilite Dyed.
- A.J-Polished, Nickel Plated and Chromium Plated.
- A.K-Hardened, Polished, Nickel Plated and Chromium Plated.
- A.L-Heat Treated for Toughness.
  - B-Polished, Nickel Plated and Buffed.
  - C-Hardened only.
- C.R-Hardened and Merlized.
  - D-Polished Only.
  - E-Soft, Not Polished.
  - F-Hardened and Polished.
- F.J-Hardened, Polished and Nickel Plated.
  - G-Bright Rumbled and Nickel Plated.
  - H-Blued.
  - J-Nickel Plated Only.
  - K-Hardened and Nickel Plated.
  - L-Brass Plated.
  - M-Oxidized.
  - N-Japanned, Dull.



INSTRUCTIONS FOR ORDERING - Continued

- P-Japanned, Bright.
- P.P-Wrinkle Finish.
- R-Merlized.
- S-Cadmium Plated.
- T-Copper Plated.
- T.A-Hardened, Polished, Copper and Nickel Plated and Buffed.
- T.B-Copper and Nickel Plated and Polished.
- T.J-Copper and Nickel Plated Only.
- T.K-Hardened, Copper and Nickel Plated.
- T.L-Copper and Brass Plated.
- T.M-Copper Plated and Oxidized.
- U-Zinc Plated.
- V-Silver Plated.
- W-Polished and Nickel Plated.
- X-Black Oxide, for Iron and Steel.
- X.C-Hardened and Black Oxide, for Iron and Steel.
- Y-Black Nickel Plated Only.
- Z-Chromium Plated.
- Z.A-Hardened, Polished, Nickel Plated, Buffed and Chromium Plated.
- Z.B-Polished, Nickel Plated, Buffed and Chromium Plated.
- Z.C-Hardened and Chromium Plated.
- Z.D-Polished and Chromium Plated.
- Z.G-Bright Rumbled, Nickel Plated, Bright Rumbled and Chromium Plated.
- Z.J-Nickel and Chromium Plated.
- Z.T-Copper and Chromium Plated.

These letters **MUST BE USED** when they appear in the list; and **AFTER** the number as in the list.

In this series:

1 to 1500, 50001 to 51500 and 140001 to 142000 are Screw Numbers.

1501 to 1800 and 51501 to 51800 are Nut Numbers.

1801 to 2000 and 51801 to 52000 are Roller Numbers.

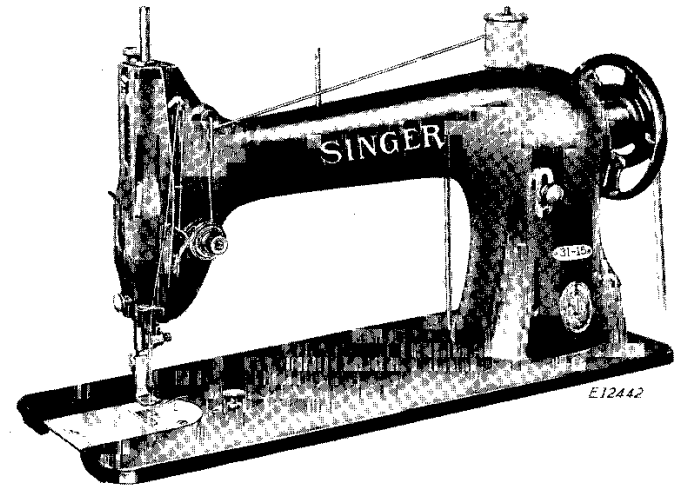
2001 to 50000 and 52001 to 140000 and 142001 to 190000 are Sewing Machine Parts, 190001 and upward are numbers of Electrical Parts.

The figures in the second column refer only to the plates, illustrating the parts, and are **NOT TO BE USED** in ordering.

Parts marked with an asterisk (\*) are furnished only when repairs are made at factory.

When ordering parts which differ as to Gauge (the distance between seams) the Gauge, as well as the Number must be given on order.

**LIST OF PARTS COMPLETE FOR**



**MACHINE No. 31-15**

**FOR CLOTH, TAILORING, ETC. DROP FEED.**

NO.	PLATE	NAME
*12355	---	Arm with 11104.....
8582	773	" Dowel Pin.....
12453	773	" Oil Tube for intermediate bearing....
11119	773	" " " with 52045, for oiling 12408
12454	773	" " " " " " " 12409
24131	2014	" " " " " " " 20283
52045	8628	" " " Packing (braided cotton)..
748E	782	" Screw (back).....
854E	783	" " (front).....
12427	766	" Shaft.....
*44122	---	" " 12427 with 20188, 20283 and 24036.....
*44189	---	Arm Shaft 44122 with 20197.....
11104	---	" " Bushing (front).....
12357	767	" " Flanged Bushing (back)....
448C	783	" " " " " " Set Screw.....

NO.	PLATE	NAME
144D	782	Arm Shaft Screw.....
12480	767	" Side Cap.....
219D	774	" " " Screw.....
12193	2004	" " " Cover.....
286D	783	" " " Thumb Screw.....
12403	772	" Spool Pin and Thread Eyelet.....
11241	2003	" " " Washer (cloth).....
12358	2000	Balance Wheel (power) light rim, 2 $\frac{3}{8}$ in. Pulley with two 448c.....
4370	2000	Balance Wheel (stand) heavy rim, 2 $\frac{3}{4}$ in. pulley with two 448c.....
2135	2000	Balance Wheel (stand) heavy rim, 2 $\frac{1}{2}$ in. pulley, for 3022.....
2862	—	Balance Wheel (stand) heavy rim, 3 in. pulley, for 3022.....
448c	783	Balance Wheel Set Screw.....
*12360	—	Bed.....
256J	2003	Clamp Stop Motion Clamp Screw.....
248A	2011	" " " " Stop Screw..
920	2003	" " " " Washer.....
*3023	—	" " " Flanged Bushing
4933	2003	" " " " " "
		3023 with two 462c.....
2022	773	Clamp Stop Motion Flanged Bushing Pin
462c	773	" " " " " Set Screw.....
3022J	—	Clamp Stop Motion complete, Nos. 248A, 256J, 2020 and 4933.....
20197	2001	Crank Connecting Rod with 20198 and two 896E.....
*20198	—	Crank Connecting Rod Cap.....
896E	773	" " " " Screw.....
908c	773	" " " " Hinge Screw.....
1619E	773	" " " " Nut..
20057	—	Face Plate.....
*44181	—	" " Thread Guard (lower).....
12150	773	" " " " " 44181 with 12152.....
12152	773	Face Plate Thread Guard (lower) Rivet...
2827	773	" " " " (upper) with 8505.....
8505	773	Face Plate Thread Guard (upper) Rivet...
190D	782	" " Screw.....
20058	5735	Face Plate complete, Nos. 2827, 12150 and 20057.....
286D	783	Face Plate Thumb Screw.....

NO.	PLATE	NAME
12368	767	Feed Bar.....
313c	783	" " Screw Centre.....
56813	—	" " " " 313c with 1519J
1519J	783	" " " " Nut.....
3033	770	" Connecting Link.....
375c	782	" " " Hinge Screw.....
1518J	783	" " " " " Nut
44252	5813	" Dog, 12 teeth (12 teeth to the inch)

NOTE: No. 44252 is sent with this machine unless  
another Feed Dog is specified on order

20349	1267	Feed Dog, 13 teeth (16 teeth to the inch)
44253	5813	" " 16 teeth (16 teeth to the inch)
43978	778	" " 24 teeth (22 teeth to the inch)
12437	777	" " 12 teeth (14 teeth to the inch) four teeth at right of needle (square corner).....
12370	2692	Feed Dog, 15 teeth (16 teeth to the inch)
12425	779	" " 13 teeth (16 teeth to the inch)
12450	777	" " 11 teeth (18 teeth to the inch)
43979	778	" " 21 teeth (22 teeth to the inch)
20348	777	" " 22 teeth (36 teeth to the inch) for chiffon.....
19474	1258	Feed Dog, 14 teeth (16 teeth to the inch) for corset work.....
20018	1258	Feed Dog, 17 teeth (15 teeth to the inch) for finishing knit underwear.....
12481	778	Feed Dog, 18 teeth (16 teeth to the inch)
20352	1267	" " 15 teeth (16 teeth to the inch) for general muslin work.....
20119	1259	Feed Dog, 18 teeth (16 teeth to the inch) for heavy work on duck, overalls, etc...
12372	778	Feed Dog, 13 teeth (12 teeth to the inch) beveled for hemmer.....
20002	778	Feed Dog, 18 teeth (16 teeth to the inch) beveled for hemmer.....
12455	779	Feed Dog, 13 teeth (14 teeth to the inch) beveled for hemmer, for shirt work....
20336	1274	Feed Dog, 16 teeth (16 teeth to the inch) beveled for hemmer, for shirt work....
12468	777	Feed Dog, 16 teeth (16 teeth to the inch) beveled for hemmer, for shirt work....
20471	777	Feed Dog, 22 teeth (22 teeth to the inch) beveled for hemmer, for shirt work....
44136	1381	Feed Dog, 15 teeth (16 teeth to the inch) for tailor work.....

NO.	PLATE	NAME
20275	1259	Feed Dog, 13 teeth (18 teeth to the inch) for umbrella work.....
208E	782	Feed Dog Screw.....
20283	2020	" and Feed Lifting Eccentric with 446c
446c	783	" " " " " Set Screw
24036	2020	" " " " " Sleeve....
20284	2020	" Forked Connection.....
375c	782	" " " " " Hinge Screw....
1518J	783	" " " " " Nut
*43993	—	Feed Forked Connection complete, Nos. 818b, 3033, 3039, 20284 and two each 375c and 1518J.....
44125	5804	Feed Lifting Rock Shaft.....
44126	—	Feed Lifting Rock Shaft complete, Nos. 12376 and 44125.....
12376	770	Feed Lifting Rock Shaft Crank with 157J and 1813.....
157J	782	Feed Lifting Rock Shaft Crank Clamping Screw.....
43976	5804	Feed Lifting Rock Shaft Crank Connecting Rod with 43977 and two 966c.....
*43977	—	Feed Lifting Rock Shaft Crank Connecting Rod Cap.....
966E	5806	Feed Lifting Rock Shaft Crank Connecting Rod Cap Screw.....
375c	782	Feed Lifting Rock Shaft Crank Connecting Rod Hinge Screw.....
1518J	783	Feed Lifting Rock Shaft Crank Connecting Rod Hinge Screw Nut.....
1813	783	Feed Lifting Rock Shaft Crank Roller and Stud.....
307c	783	Feed Lifting Rock Shaft Screw Centre....
56814	—	" " " " " " 307c with 1513J.....
1513J	783	Feed Lifting Rock Shaft Screw Centre Nut
3039	768	" Regulator.....
1128E	2009	" " " Hinge Screw.....
818D	783	" " " Thumb Screw.....
12379	766	" Rock Shaft.....
29633	5736	" " " Crank with 157J.....
157J	782	" " " " Clamping Screw
20333	—	Feed Rock Shaft complete, Nos. 12379 and 29633.....
307c	783	Feed Rock Shaft Screw Centre.....
56814	—	" " " " " " 307c with 1513J.....
1513J	783	Feed Rock Shaft Screw Centre Nut.....

NO.	PLATE	NAME
12381	767	Needle Bar (hollow).....
*12382	770	" " " Connecting Link with 794E....
43997	—	" " " " " 12382 with 12384.....
794E	782	Needle Bar Connecting Link Adjusting Screw.....
*12383	—	Needle Bar Connecting Stud.....
1904	770	" " " " " Roller (roller only).....
453c	783	Needle Bar Connecting Stud Set Screw..
12384	770	Needle Bar Connecting Stud complete, Nos. 453c, 1904 and 12383.....
20188	767	Needle Bar Crank with 858c and 1065c..
1065c	2011	" " " " Position Screw.....
858c	783	" " " " Set Screw.....
936E	773	" " " Screw Bushing.....
4302	773	" " " Thread Guide.....
233D	782	" " " " " Screw.....
4303	773	" Clamp with 808F.....
808F	782	" " " " " Screw.....
*24104	2001	Oscillating Rock Shaft.....
24105	—	Oscillating Rock Shaft complete, Nos. 4784, 12388 and 24104.....
12388	767	Oscillating Rock Shaft Hinge Pin....
448c	783	" " " " " " " Set Screw.....
4784	1353	Oscillating Rock Shaft Oil Pad.....
12389	766	" " Shaft.....
19496	—	" " " Crank for 19447.....
44134	—	" " " " " 44135.....
2049	773	" " " " " Pin.....
457c	783	" " " " " " Set Screw for 19447
453c	783	" " " " " " " 44135
19448	2011	" " " " " Slide Block....
226D	1371	" " " " " " " Cap Screw.....
12424	773	Oscillating Shaft Crank Slide Block Cap Screw Washer.....
988c	2011	Oscillating Shaft Crank Slide Block Screw Stud.....
1518J	783	Oscillating Shaft Crank Slide Block Screw Stud Nut.....
19449	2011	Oscillating Shaft Crank Slide Block complete, Nos. 226D, 988c, 12424 and 19448
19447	2011	Oscillating Shaft Crank complete, Nos. 457c, 1518J, 19449 and 19496.....

## PARTS FOR MACHINE No. 31-15

NO.	PLATE	NAME
44135	5806	Oscillating Shaft Crank complete, Nos. 1518J, 19449, 44134 and two 453c.....
12391	767	Presser Bar (hollow).....
20059	5736	" " Guide Bracket with 453c.....
453c	783	" " " " Set Screw.....
2062	771	" " Lifter.....
689c	782	" " " " Screw.....
1520J	783	" " " " Nut.....
12327	770	" " Lifting and Releasing Lever Bracket.....
11167	767	Presser Bar Spring (light) .051 wire.....

NOTE: No. 11167 is sent with this machine unless another Spring is specified on order

12139	2004	Presser Bar Spring (medium) .055 wire...
20023	2004	" " " (heavy) .063 wire.....
11170	771	" " " Washer.....
12143	780	" Foot for 12369, 12457 and 20349..

NOTE: No. 12143 is sent with this machine unless another Presser Foot is specified on order

12335	1308	Presser Foot (narrow) for 12369, 12457 and 20349.....
12258	1308	Presser Foot (wide) for 12369, 12457 and 20349.....
20343	781	Presser Foot with Guide on bottom to the right of needle hole, for 12369, 12450 and 12457.....
12142	780	Presser Foot for 12370 and 20352.....
12144	780	" " " 12372, 12437, 12455, 12468, 12481, 20002, 20336 and 20471
12474	1308	Presser Foot for 12372, 12481 and 20002...
12260	780	" " " 12437, 12450 and 20348...
12259	780	" " " 12425, 12481, 19474 and 20119.....
20342	781	Presser Foot for 12450 and 20348.....
12261	1308	" " " 12481.....
20276	1259	" " " 20275.....
20020	1308	" " " 20018.....
20458	780	" " " 44136.....
12348	5837	" " " outside stays and strips
12311	5837	" " " shirt work.....
12467	781	" " " umbrella work.....
7298	2014	" " Hinge Pin.....
20268	—	" " Plate.....
20269	—	" " Shank.....

## PARTS FOR MACHINE No. 31-15

NO.	PLATE	NAME
20270	1308	Presser Foot (hinged) complete for 12369, 12457 and 20349, Nos. 7298, 20268 and 20269.....
7298	2014	Presser Foot Hinge Pin.....
19334	—	" " Plate.....
19335	—	" " Shank.....
19336	1308	Presser Foot (hinged) complete for 12370, 43979 and 44136, Nos. 7298, 19334 and 19335.....
62527	5806	Presser Foot Hinge Pin.....
20310	—	" " Plate.....
19223	—	" " Shank.....
20311	781	Presser Foot (hinged) complete for 12372, 12437, 12455, 12468, 12481, 20002, 20336 and 20471, Nos. 19223, 20310 and 62527.....
62527	5806	Presser Foot Hinge Pin.....
20344	—	" " Plate.....
20345	—	" " Shank.....
26231	2014	" " Spring.....
20346	781	Presser Foot (spring hinged) complete for 12372, 12437, 12455, 12468, 12481, 20002, 20336 and 20471, Nos. 20344, 20345, 26231 and 62527.....
62527	5806	Presser Foot Hinge Pin.....
24544	—	" " Plate.....
24982	—	" " Shank.....
26231	2014	" " Spring.....
24983	781	Presser Foot (spring hinged) complete for 12425, 12481, 19474 and 20119, Nos. 24544, 24982, 26231 and 62527.....
190D	782	Presser Foot Screw.....
688J	783	Pressure Regulating Thumb Screw.....
2996	771	Shuttle Bobbin.....
62739	—	" " Case.....
15140	2013	" " " Latch.....
2973	771	" " " Lever.....
2974	771	" " " " Fulcrum Pin.....
2975	771	Shuttle Bobbin Case Latch Spring.....
592E	782	" " " " Stop Screw..
15141	—	Shuttle Bobbin Case Hinge, Nos. 2973, 2974 and 15140.....
7553	771	Shuttle Bobbin Case Position Finger.....
2523	771	" " " " " Rivet
24412	1361	" " " " Plate.....
391D	1366	" " " " " Screw

## PARTS FOR MACHINE No. 31-15

NO.	PLATE	NAME
62740	771	Shuttle Bobbin Case complete, Nos. 591F, 592E, 2523, 2975, 7553, 15141, 15278 and 62739
12393	771	Shuttle Body
591F	782	" Tension Regulating Screw
15278	771	" Spring
19292	771	Shuttle, 1 1/8 in. diam., Nos. 2996, 12393 and 62740
*12394	—	Shuttle Driver
12444	771	" " 12394 with two 1266c
2049	773	" " Pin
1266c	5806	" " Set Screw
2531	767	" Race Back
2532	772	" " Position Pin
2533	767	" " Spring
907D	782	" " Screw
24413	—	" " Body
25000	—	" " 24413 with 24414 and two 1053D
24414	5837	Shuttle Race Cap
1053D	2006	" " Screw
24415	1361	Shuttle Race complete, Nos. 907D, 2531, 2533, 24412, 25000 and two each 391D and 2532
145D	782	Shuttle Race Screw
12431	—	" " Slide
4307	772	" " Spring
725E	1387	" " Screw
12432	2004	Shuttle Race Slide complete, Nos. 4307, 12431 and two 725E
20060	5736	Slack Thread Regulator
225F	5736	" " Adjusting Screw
2102	5806	Tension Disc
1560c	783	" Regulating Thumb Nut
32572	5806	" Releasing Disc
43944	5806	" Lever
12398	773	" " Hinge Pin
12329	772	" " Spring
32574	5806	" Pin
50327c	5806	" Screw Stud
44141	—	" " 50327c with 1560c
43945	5806	" Spring
44118	—	Tension complete, Nos. 7336, 32572, 32574, 43945, 43946, 44141 and two 2102
52454	5842	Thread Retainer
624c	8628	" " Set Screw

## PARTS FOR MACHINE No. 31-15

NO.	PLATE	NAME
12404	770	Thread Take-up Crank
3094	773	" " Wedge
690E	782	" " Screw
12408	770	" " Lever
775E	782	" " Cap Screw
12166	773	" " Hinge Pin
12409	770	" " Link
11204	770	" " Hinge Pin
435c	5806	" " " " " " Set Screw
12410	—	Thread Take-up Lever complete, Nos. 12166, 12408 and 12409
43946	5806	Thread Take-up Spring
7336	772	" " Regulator
448c	783	" " Set Screw
43990	—	Thread Take-up complete, Nos. 775E, 11204, 12404, 12410 and 43997
44256	—	Throat Plate, large needle hole, for 44252 and 44253
NOTE: Two No. 44256 are sent with this machine unless other Throat Plates are specified on order		
44255	5813	Throat Plate, small needle hole, for 44252 and 44253
12412	778	Throat Plate, large needle hole, for 12370 and 43979
12414	—	Throat Plate, large needle hole, for 12372 and 20002
12442	778	Throat Plate, small needle hole, for 12372 and 20002
12426	779	Throat Plate, large needle hole, for 12425
12466	—	" " small needle hole, for 12425
12465	—	" " large needle hole, for 12437
12440	777	" " small needle hole, for 12437
12464	777	" " large needle hole, for 12450 and 20348
12451	2689	Throat Plate, small needle hole, for 12450 and 20348
20398	—	Throat Plate, large needle hole, for 12455
12456	779	" " small needle hole, for 12455
12469	—	" " large needle hole, for 12468 and 20471
12470	777	Throat Plate, small needle hole, for 12468 and 20471
12482	—	Throat Plate, large needle hole, for 12481 and 43978

NO.	PLATE	NAME
12483	778	Throat Plate, small needle hole, for 12481 and 43978.....
20120	1259	Throat Plate large oblong needle hole, for 20119.....
20187	—	Throat Plate, small oblong needle hole, for 20119.....
20277	1259	Throat Plate, large needle hole, for 20275
20362	—	“ “ small needle hole, for 20275
20337	—	“ “ large needle hole, for 20336
20338	1274	“ “ small needle hole, for 20336
20350	1267	“ “ large needle hole, for 20349
20351	—	“ “ small needle hole, for 20349
19475	1258	“ “ large needle hole, for 19474
24572	2067	“ “ small needle hole, for 19474
20019	1258	“ “ large needle hole, for 20018
20353	1267	“ “ “ “ “ “ 20352
20354	—	“ “ small needle hole, for 20352
44137	1381	“ “ large needle hole, for 44136
44138	—	“ “ small needle hole, for 44136
691F	782	“ “ Screw.....
44212	5844	Drip Pan with four 1 in. wire nails, for power table.....

**SINGER** Needles should be used  
 in **SINGER** Machines  
 These Needles and their Containers  
 are marked with the  
 Company's Trade Mark "SIMANCO."\*\* 1

Needles in Containers marked  
 "FOR SINGER MACHINES"  
 are NOT **SINGER** made needles. 2

## LIST OF PARTS COMPLETE FOR MACHINE No. 31-16

**FOR MACKINTOSH AND GOSSAMER WORK. HAS SPECIAL  
 SHUTTLE AND SECTIONAL RACE FOR EASY REMOVAL OF  
 SHUTTLE FOR CLEANING. DROP FEED, SPECIAL PRESSER  
 FOOT AND OIL CUP. BOBBIN No. 2996.**

NO.	PLATE	NAME
*12355	—	Arm with 11104.....
8582	773	“ Dowel Pin.....
12453	773	“ Oil Tube for intermediate bearing....
11119	773	“ “ “ with 52045, for oiling 12408
12454	773	“ “ “ “ “ “ 12409
24131	2014	“ “ “ “ “ “ 20283
52045	8628	“ “ “ Packing (braided cotton) ..
748E	782	“ Screw (back).....
854E	783	“ “ (front).....
12427	766	“ Shaft.....
*44122	—	“ Shaft 12427 with 20188, 20283 and 24036.....
*44189	—	Arm Shaft 44122 with 20197.....
*11104	—	“ “ Bushing (front).....
12357	767	“ “ Flanged Bushing (back).....
448c	783	“ “ “ “ “ Set Screw
144b	782	“ “ Screw.....
12480	767	“ Side Cap.....
219b	774	“ “ Screw.....
12193	2004	“ “ Cover.....
286b	783	“ “ “ Thumb Screw.....
12403	772	“ Spool Pin and Thread Eyelet.....
11241	2003	“ “ “ Washer (cloth).....
12358	2000	Balance Wheel (power) light rim, 2 $\frac{3}{8}$ in. pulley with two 448c.....
4370	2000	Balance Wheel (stand) heavy rim, 2 $\frac{3}{4}$ in. pulley with two 448c.....
2135	2000	Balance Wheel (stand) heavy rim, 2 $\frac{1}{2}$ in. pulley, for 3022.....
2862	—	Balance Wheel Stand (heavy rim) 3 in. pulley, for 3022.....
448c	783	Balance Wheel Set Screw.....
*12360	—	Bed.....
256j	2003	Clamp Stop Motion Clamp Screw.....
248A	2011	“ “ “ “ “ Stop Screw....
2020	2003	“ “ “ “ “ Washer.....

NO.	PLATE	NAME
*3023	—	Clamp Stop Motion Flanged Bushing...
4933	2003	“ “ “ “ “ 3023 with two 462c.....
2022	773	Clamp Stop Motion Flanged Bushing Pin
462c	773	“ “ “ “ “ Set Screw.....
3022j	—	Clamp Stop Motion complete, Nos. 248A, 256j, 2020 and 4933.....
20197	2001	Crank Connecting Rod with 20198 and two 896E.....
*20198	—	Crank Connecting Rod Cap.....
896E	773	“ “ “ “ “ Screw.....
908c	773	“ “ “ “ “ Hinge Screw.....
1619E	773	“ “ “ “ “ Nut.
20057	—	Face Plate.....
*44181	—	“ “ Thread Guard (lower).....
12150	773	“ “ “ “ “ 44181 with 12152.....
12152	773	Face Plate Thread Guard (lower) Rivet..
2827	773	“ “ “ “ “ (upper) with 8505.....
8505	773	Face Plate Thread Guard (upper) Rivet
20058	5735	Face Plate complete, Nos. 2827, 12150 and 20057.....
190D	782	Face Plate Screw.....
286D	783	“ “ Thumb Screw.....
12368	767	Feed Bar.....
313c	783	“ “ Screw Centre.....
56813	—	“ “ “ “ “ 313c with 1519j
1519j	783	“ “ “ “ “ Nut.....
3033	770	“ Connecting Link.....
375c	782	“ “ “ “ “ Hinge Screw.....
1518j	783	“ “ “ “ “ “ Nut..
12481	778	“ Dog, 18 teeth (16 teeth to the inch)

NOTE: No. 12481 is sent with this machine unless  
another Feed Dog is specified on order

43978	778	Feed Dog, 24 teeth (22 teeth to the inch)
208E	782	“ “ Screw.....
20283	2020	“ and Feed Lifting Eccentric with 446c
446c	783	“ “ “ “ “ Set Screw
24036	2020	“ “ “ “ “ Sleeve...
20284	2020	“ Forked Connection.....
375c	782	“ “ “ “ “ Hinge Screw....
1518j	783	“ “ “ “ “ “ Nut

NO.	PLATE	NAME
*43993	—	Feed Forked Connection complete, Nos. 818D, 3033, 3039, 20284 and two each 375c and 1518j.....
44125	5804	Feed Lifting Rock Shaft.....
44126	—	Feed Lifting Rock Shaft complete, Nos. 12376 and 44125.....
12376	770	Feed Lifting Rock Shaft Crank with 157j and 1813.....
157j	782	Feed Lifting Rock Shaft Crank Clamping Screw.....
43976	5804	Feed Lifting Rock Shaft Crank Connecting Rod with 43977 and two 966E.....
*43977	—	Feed Lifting Rock Shaft Crank Connecting Rod Cap.....
966E	5806	Feed Lifting Rock Shaft Crank Connecting Rod Cap Screw.....
375c	782	Feed Lifting Rock Shaft Crank Connecting Rod Hinge Screw.....
1518j	783	Feed Lifting Rock Shaft Crank Connecting Rod Hinge Screw Nut.....
1813	783	Feed Lifting Rock Shaft Crank Roller and Stud.....
307c	783	Feed Lifting Rock Shaft Screw Centre...
56814	—	“ “ “ “ “ “ 307c with 1513j.....
1513j	783	Feed Lifting Rock Shaft Screw Centre Nut
3039	768	“ Regulator.....
1128E	2009	“ “ Hinge Screw.....
818D	783	“ “ Thumb Screw.....
12379	766	“ Rock Shaft.....
29633	5736	“ “ “ “ “ Crank with 157j.....
157j	782	“ “ “ “ “ Clamping Screw
20333	—	Feed Rock Shaft complete, Nos. 12379 and 29633.....
307c	783	Feed Rock Shaft Screw Centre.....
56814	—	“ “ “ “ “ “ 307c with 1513j.....
1513j	783	Feed Rock Shaft Screw Centre Nut.....
12381	767	Needle Bar (hollow).....
*12382	770	“ “ Connecting Link with 794E..
43997	—	“ “ “ “ “ 12382 with 12384.....
794E	782	Needle Bar Connecting Link Adjusting Screw.....
*12383	—	Needle Bar Connecting Stud.....
1904	770	“ “ “ “ “ Roller (roller only).....

NO.	PLATE	NAME
453c	783	Needle Bar Connecting Stud Set Screw...
12384	770	Needle Bar Connecting Stud complete, Nos. 453c, 1904 and 12383.....
20188	767	Needle Bar Crank with 858c and 1065c....
1065c	2011	" " " Position Screw.....
858c	783	" " " Set Screw.....
936E	773	" " Screw Bushing.....
4302	773	" " Thread Guide.....
233D	782	" " " Screw.....
4303	773	" Clamp with 808F.....
808F	782	" " Screw.....
44222	—	Oil Cup.....
44223	—	" " 44222 with 44005.....
44214	—	" " Extension.....
44005	2565	" " " 44214 with 24075.....
24075	2565	" " " Post.....
44006	2565	" " Packing (felt).....
44224	8628	" " Thread Retainer.....
44225	8628	Oil Cup complete, Nos. 44006, 44223 and 44224.....
*24104	2001	Oscillating Rock Shaft.....
24105	—	Oscillating Rock Shaft complete, Nos. 4784, 12388 and 24104.....
12388	767	Oscillating Rock Shaft Hinge Pin.....
448c	783	" " " " " Set Screw.....
4784	1353	" " " Oil Pad.....
12389	766	" Shaft.....
19496	—	" " Crank for 19477.....
44134	—	" " " 44135.....
2049	773	" " " Pin.....
457c	783	" " " Set Screw for 19447.....
453c	783	" " " " " 44135.....
19448	2011	" " " Slide Block.....
226D	1371	" " " " " Cap Screw.....
12424	773	Oscillating Shaft Crank Slide Block Cap Screw Washer.....
988c	2011	Oscillating Shaft Crank Slide Block Screw Stud.....
1518J	783	Oscillating Shaft Crank Slide Block Screw Stud Nut.....
19449	2011	Oscillating Shaft Crank Slide Block com- plete, Nos. 226D, 988c, 12424 and 19448
19447	2011	Oscillating Shaft Crank complete, Nos. 457c, 1518J, 19449 and 19496.....
44135	5806	Oscillating Shaft Crank complete, Nos. 1518J, 19449, 44134 and two 453c.....

NO.	PLATE	NAME
12391	767	Presser Bar (hollow).....
20059	5736	" " Guide Bracket with 453c....
453c	783	" " " " Set Screw....
2062	771	" " Lifter.....
689c	782	" " " Screw.....
1520J	783	" " " " Nut.....
12327	770	" " Lifting and Releasing Lever Bracket.....
11167	767	Presser Bar Spring (light) .051 wire.....

NOTE: No. 11167 is sent with this machine unless  
another Spring is specified on order

12139	2004	Presser Bar Spring (medium) .055 wire...
20023	2004	" " " (heavy) .063 wire....
11170	771	" " " Washer.....
62527	5806	" Foot Hinge Pin.....
24544	—	" " Plate.....
24982	—	" " Shank.....
26231	2014	" " Spring.....
24983	781	Presser Foot (spring hinged) complete for 12481, Nos. 24544, 24982, 26231 and 62527.....

NOTE: No. 24983 is sent with this machine unless  
another Presser Foot is specified on order

12144	780	Presser Foot for 12481.....
12261	1308	" " " 12481.....
12474	1308	" " " 12481.....
62527	5806	" " Hinge Pin.....
20310	—	" " Plate.....
19223	—	" " Shank.....
20311	781	Presser Foot (hinged) complete for 12481, Nos. 19223, 20310 and 62527.....
190D	782	Presser Foot Screw.....
688J	783	Pressure Regulating Thumb Screw.....
2996	771	Shuttle Bobbin.....
62739	—	" " Case.....
15140	2013	" " " Latch.....
2973	771	" " " " Lever.....
2974	771	" " " " " Fulcrum Pin.....
2975	771	Shuttle Bobbin Case Latch Spring.....
592E	782	" " " " Stop Screw...
15141	—	Shuttle Bobbin Case Hinge, Nos. 2973, 2974 and 15140.....
7553	771	Shuttle Bobbin Case Position Finger.....
2523	771	" " " " " Rivet



NO.	PLATE	NAME
62740	771	Shuttle Bobbin Case complete, Nos. 591F, 592E, 2523, 2975, 7553, 15141, 15278 and 62739.....
12488	2013	Shuttle Body.....
591F	782	" Tension Regulating Screw.....
15278	771	" " Spring.....
12487	—	Shuttle, 1 $\frac{1}{4}$ in. diam., Nos. 2996, 12488 and 62740.....
*12394	—	Shuttle Driver.....
12444	771	" " 12394 with two 1266c.....
2049	773	" " Pin.....
1266c	5806	" " Set Screw.....
2531	767	" Race Back.....
2532	772	" " " Position Pin.....
2533	767	" " " Spring.....
648D	782	" " " " Screw.....
20003	—	" " Body.....
20004	2005	" " Cap.....
662D	782	" " " Screw.....
12492	2005	" " Ring.....
12493	2005	" " " Clamp (left).....
12494	2005	" " " (right).....
21202	5837	" " " " Friction Spring.....
85D	2005	" " " " Screw.....
20005	2005	Shuttle Race (sectional) complete, Nos. 648D, 2531, 2533, 12492 to 12494, 20003, 20004 and two each 85D, 662D, 2532 and 21202.....
145D	782	Shuttle Race Screw.....
12431	—	" " Slide.....
4307	772	" " " Spring.....
725E	1387	" " " " Screw.....
12432	2004	Shuttle Race Slide complete, Nos. 4307, 12431 and two 725E.....
20060	5736	Slack Thread Regulator.....
225F	5736	" " " Adjusting Screw.....
2102	5806	Tension Disc.....
1560c	783	" Regulating Thumb Nut.....
32572	5806	" Releasing Disc.....
43944	5806	" " Lever.....
12398	773	" " " Hinge Pin.....
12329	772	" " " Spring.....
32574	5806	" " Pin.....
50327c	5806	" Screw Stud.....
44141	—	" " " 50327c with 1560c.....
43945	5806	" Spring.....

NO.	PLATE	NAME
44118	—	Tension complete, Nos. 7336, 32572, 32574, 43945, 43946, 44141 and two 2102.....
52454	5842	Thread Retainer.....
624c	8628	" " Set Screw.....
12404	770	" Take-up Crank.....
3094	773	" " " Wedge.....
690E	782	" " " " Screw.....
12408	770	" " Lever.....
775E	782	" " " Cap Screw.....
12166	773	" " " Hinge Pin.....
12409	770	" " " Link.....
11204	770	" " " " Hinge Pin.....
435c	5806	" " " " " Set Screw.....
12410	—	Thread Take-up Lever complete, Nos. 12166, 12408 and 12409.....
43946	5806	Thread Take-up Spring.....
7336	772	" " " Regulator.....
448c	783	" " " " Set Screw.....
*43990	—	Thread Take-up complete, Nos. 775E, 11204, 12404, 12410 and 43997.....
12482	—	Throat Plate, large needle hole, for 12481 and 43978.....
12483	778	Throat Plate, small needle hole, for 12481 and 43978.....
NOTE: Two No. 12483 are sent with this machine unless other Throat Plates are specified on order		
691F	782	Throat Plate Screw.....
44212	5844	Drip Pan with four 1 in. wire nails for power table.....

**LIST OF PARTS COMPLETE  
FOR  
MACHINE No. 31-19**

**FOR ENAMELED OR PLAIN CLOTH; ALSO LIGHT LEATHER.  
ESPECIALLY USEFUL FOR FABRICS OF UNEVEN THICK-  
NESS. HAS DROP FEED, ALTERNATING PRESSERS AND  
BOBBIN No. 2996**

NO.	PLATE	NAME
*20339	—	Arm with 11104.....
8582	773	" Dowel Pin.....
12453	773	" Oil Tube for intermediate bearing..
11119	773	" " " with 52045, for oiling 12408 and 19365.....
12454	773	Arm Oil Tube with 52045, for oiling 12409
24131	2014	" " " " " " " 20283
52045	8628	" " " Packing (braided cotton)...
748E	782	" Screw (back).....
854E	783	" " (front).....
12427	766	" Shaft.....
*44121	—	" " 12427 with 20283, 24036 and 62637.....
*44195	—	Arm Shaft 44121 with 20197.....
*11104	—	" " Bushing (front).....
12357	767	" " Flanged Bushing (back).....
448C	783	" " " " " " " " SetScrew
144D	782	" " Screw.....
12193	2094	" Side Cover.....
236D	783	" " " Screw.....
12403	772	Arm Spool Pin and Thread Eyelet.....
11241	2003	" " " Washer (cloth).....
12358	2000	Balance Wheel (power) light rim, 2 $\frac{3}{8}$ in. pulley with two 448c.....
4370	2000	Balance Wheel (stand) heavy rim, 2 $\frac{3}{4}$ in. pulley with two 448c.....
2135	2000	Balance Wheel (stand) heavy rim, 2 $\frac{1}{2}$ in. pulley, for 3022.....
2862	—	Balance Wheel (stand) heavy rim, 3 in. pulley, for 3022.....
448C	783	Balance Wheel Set Screw.....
*12360	—	Bed.....
256J	2003	Clamp Stop Motion Clamp Screw.....
248A	2011	" " " " " Stop Screw..
2020	2003	" " " " " Washer.....

NO.	PLATE	NAME
*3023	—	Clamp Stop Motion Flanged Bushing.....
4933	2003	" " " " " " 3023 with two 462c.....
2022	773	Clamp Stop Motion Flanged Bushing Pin
462C	773	" " " " " " Set Screw.....
3022J	—	Clamp Stop Motion complete, Nos. 248A, 256J, 2020 and 4933.....
20197	2001	Crank Connecting Rod with 20198 and two 896E.....
*20198	—	Crank Connecting Rod Cap.....
896E	773	" " " " " Screw.....
908C	773	" " " " " Hinge Screw....
1619E	773	" " " " " " Nut
19354	—	Face Plate.....
*44181	—	" " Thread Guard (lower).....
12150	773	" " " " " " 44181 with 12152.....
12152	773	Face Plate Thread Guard (lower) Rivet
2827	773	" " " " " (upper) with 8505.....
8505	773	Face Plate Thread Guard (upper) Rivet
19355	5735	Face Plate complete, Nos. 2827, 12150 and 19354.....
219D	774	Face Plate Screw.....
12368	767	Feed Bar.....
313C	783	" " Screw Centre.....
56813	—	" " " " " 313c with 1519J
1519J	783	" " " " " Nut.....
3033	770	" Connecting Link.....
375C	782	" " " " " Hinge Screw....
1518J	783	" " " " " " Nut
12370	2692	" Dog, 15 teeth (16 teeth to the inch)
NOTE: No. 12370 is sent with this machine unless another Feed Dog is specified on order		
20106	1259	Feed Dog, 13 teeth (16 teeth to the inch)
44252	5813	" " " 12 teeth (12 teeth to the inch)
44253	5813	" " " 16 teeth (16 teeth to the inch)
43979	778	" " " 21 teeth (22 teeth to the inch)
208E	782	" " Screw.....
20283	2020	" and Feed Lifting Eccentric with 446c
446C	783	" " " " " " Set Screw
24036	2020	" " " " " " Sleeve...
20284	2020	" Forked Connection.....
375C	782	" " " " " Hinge Screw....
1518J	783	" " " " " " Nut



NO.	PLATE	NAME
19375	1313	Lifting Presser Foot for 19374 and 19376
193D	1312	" " " Screw.....
12381	767	Needle Bar (hollow).....
*12382	770	" " Connecting Link with 794E..
43997	—	" " " " 12382 with 12384.....
794E	782	Needle Bar Connecting Link Adjusting Screw.....
*12383	—	Needle Bar Connecting Stud.....
1904	770	" " " " Roller (roller only).....
453c	783	Needle Bar Connecting Stud Set Screw...
12384	770	Needle Bar Connecting Stud complete, Nos. 453c, 1904 and 12383.....
19365	767	Needle Bar Crank and Lifting Eccentric with 448c and 743c.....
743c	1313	Needle Bar Crank and Lifting Eccentric Position Screw.....
448c	783	Needle Bar Crank and Lifting Eccentric Set Screw.....
936E	773	Needle Bar Screw Bushing.....
✓4302	773	" " Thread Guide.....
233D	782	" " " " Screw.....
4303	773	" Clamp with 808F.....
808F	782	" " " " Screw.....
*24104	2001	Oscillating Rock Shaft.....
24105	—	Oscillating Rock Shaft complete, Nos. 4784, 12388 and 24104.....
12388	767	Oscillating Rock Shaft Hinge Pin.....
448c	783	" " " " " Set Screw
4784	1353	" " " " Oil Pad.....
12389	766	" Shaft.....
19496	—	" " Crank for 19447.....
44134	—	" " " " 44135.....
2049	773	" " " " Pin.....
457c	783	" " " " Set Screw for 19447.....
453c	783	Oscillating Shaft Crank Set Screw for 44135.....
19448	2011	Oscillating Shaft Crank Slide Block.....
226D	1371	" " " " " Cap. Screw.....
12424	773	Oscillating Shaft Crank Slide Block Cap Screw Washer.....

NO.	PLATE	NAME
988c	2011	Oscillating Shaft Crank Slide Block Screw Stud.....
1518J	783	Oscillating Shaft Crank Slide Block Screw Stud Nut.....
19449	2011	Oscillating Shaft Crank Slide Block com- plete, Nos. 226D, 988c, 12424 and 19448
19447	2011	Oscillating Shaft Crank complete, Nos. 457c, 1518J, 19449 and 19496.....
44135	5806	Oscillating Shaft Crank complete, Nos. 1518J, 19449, 44134 and two 453c.....
688J	783	Pressure Regulating Thumb Screw.....
2996	771	Shuttle Bobbin.....
62739	—	" " Case.....
15140	2013	" " " " Latch.....
2973	771	" " " " " Lever.....
2974	771	" " " " " Fulcrum Pin.....
2975	771	Shuttle Bobbin Case Latch Spring.....
592E	782	" " " " " Stop Screw..
15141	—	Shuttle Bobbin Case Hinge, Nos. 2973, 2974 and 15140.....
7553	771	Shuttle Bobbin Case Position Finger....
2523	771	" " " " " Rivet
24412	1361	" " " " " Plate.....
391D	1366	" " " " " Screw
✓62740	771	Shuttle Bobbin Case complete, Nos. 591F, 592E, 2523, 2975, 7553, 15141, 15278 and 62739.....
12393	771	Shuttle Body.....
591F	782	" Tension Regulating Screw.....
15278	771	" " " Spring.....
19292	771	Shuttle, 1½ in. diam., Nos. 2996, 12393 and 62740.....
*12394	—	Shuttle Driver.....
12444	771	" " 12394 with two 1266c....
2049	773	" " Pin.....
1266c	5806	" " Set Screw.....
2531	767	" Race Back.....
2532	772	" " " Position Pin.....
2533	767	" " " Spring.....
907D	782	" " " " " Screw.....
24413	—	" " " Body.....
62502	—	" " " 24413 with 24418 and two 1053D.....
24418	—	Shuttle Race Cap.....
1053D	2006	" " " " " Screw.....

## PARTS FOR MACHINE No. 31-19

NO.	PLATE	NAME
24419	—	Shuttle Race complete, Nos. 907D, 2531, 2533, 24412, 62502 and two each 391d and 2532.....
145D	782	Shuttle Race Screw.....
12431	—	“ “ Slide.....
4307	772	“ “ “ Spring.....
725E	1387	“ “ “ “ Screw.....
12432	2004	Shuttle Race Slide complete, Nos. 4307, 12431 and two 725E.....
2102	5806	Tension Disc.....
1560c	783	“ Regulating Thumb Nut.....
32572	5806	“ Releasing Disc.....
43944	5806	“ “ Lever.....
12398	773	“ “ “ Hinge Pin.....
12329	772	“ “ “ Spring.....
32574	5806	“ “ Pin.....
50327c	5806	“ Screw Stud.....
*44141	—	“ “ 50327c with 1560c.....
43945	5806	“ Spring.....
12149	2014	“ Thread Guard.....
44118	—	Tension complete, Nos. 7336, 32572, 32574, 43945, 43946, 44141 and two 2102.....
52454	5842	Thread Retainer.....
624c	8628	“ “ Set Screw.....
12404	770	“ Take-up Crank.....
3094	773	“ “ “ Wedge.....
690E	782	“ “ “ “ Screw.....
12408	770	“ “ Lever.....
775E	782	“ “ “ Cap Screw.....
12166	773	“ “ “ Hinge Pin.....
12409	770	“ “ “ Link.....
11204	770	“ “ “ “ Hinge Pin.....
435c	5806	“ “ “ “ “ “ Set Screw.....
12410	—	Thread Take-up Lever complete, Nos. 12166, 12408 and 12409.....
43946	5806	Thread Take-up Spring.....
7336	772	“ “ “ Regulator.....
448c	783	“ “ “ “ Set Screw.....
*43990	—	Thread Take-up complete, Nos. 775E, 11204, 12404, 12410 and 43997.....
12412	778	Throat Plate, large needle hole, for 12370 and 43979.....

NOTE: Two No. 12412 are sent with this machine unless other Throat Plates are specified on order

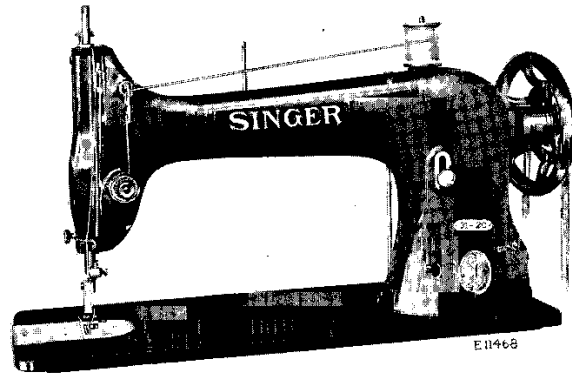
## PARTS FOR MACHINE No. 31-19

NO.	PLATE	NAME
20315	—	Throat Plate, large needle hole, for 20106
20107	1259	“ “ small needle hole, for 20106
44256	—	“ “ large needle hole, for 44252 and 44253.....
44255	5813	Throat Plate, small needle hole, for 44252 and 44253.....
691F	782	Throat Plate Screw.....
19366	1313	Vibrating Presser Bar.....
19367	1313	“ “ “ Cap.....
199D	1312	“ “ “ “ Screw for 19366
219F	774	“ “ “ “ “ “ 19367
19368	1313	“ “ “ Cushion (rawhide)
19369	1313	Vibrating Presser Bar Spring.....
335D	1313	“ “ “ “ Screw.....
19370	1312	“ “ Foot for 12370 and 43979
19374	1313	“ “ “ “ 12369 and 12457
19376	1313	“ “ “ “ 20106.....
217D	1312	“ “ “ “ Screw.....
44212	5844	Drip Pan with four 1 in. wire nails, for power table.....

SINGER Needles should be used  
in SINGER Machines  
These Needles and their Containers  
are marked with the  
Company's Trade Mark "SIMANCO.\*\*" 1

Needles in Containers marked  
"FOR SINGER MACHINES"  
are NOT SINGER made needles. 2

**LIST OF PARTS COMPLETE  
FOR**



**MACHINE No. 31-20**

**FOR CLOTH. THROAT PLATE FLUSH WITH BED. DROP FEED.**

NO.	PLATE	NAME
*12355	—	Arm with 11104.....
8582	773	" Dowel Pin.....
12453	773	" Oil Tube for intermediate bearing...
12454	773	" " " with 52045 for oiling 12409
11119	773	" " " " " " " 12408
24131	2014	" " " " " " " 20283
52045	8628	" " " Packing (braided cotton)...
748E	782	" Screw (back).....
854E	783	" " (front).....
12427	766	" Shaft.....
*44122	—	" " 12427 with 20188, 20283 and 24036.....
*44189	—	Arm Shaft 44122 with 20197.....
*11104	—	" " Bushing (front).....
12357	767	" " Flanged Bushing (back).....
448c	783	" " " " " Set Screw.....

NO.	PLATE	NAME
144d	782	Arm Shaft Screw.....
12480	767	" Side Cap.....
219d	774	" " " Screw.....
12193	2004	" " Cover.....
286d	783	" " " Thumb Screw.....
12403	772	" Spool Pin and Thread Eyelet.....
11241	2003	" " " Washer (cloth).....
12358	2000	Balance Wheel (power) light rim, 2 $\frac{1}{8}$ in. pulley with two 448c.....
4370	2000	Balance Wheel (stand) heavy rim, 2 $\frac{3}{4}$ in. pulley with two 448c.....
2135	2000	Balance Wheel (stand) heavy rim, 2 $\frac{1}{2}$ in. pulley for 3022.....
2862	—	Balance Wheel (stand) heavy rim, 3 in. pulley for 3022.....
448c	783	Balance Wheel Set Screw.....
*12360	—	Bed.....
256j	2003	Clamp Stop Motion Clamp Screw.....
248A	2011	" " " " Stop Screw...
2020	2003	" " " " Washer.....
*3023	—	" " " Flanged Bushing....
4933	2003	" " " " " 3023 with two 462c.....
2022	773	Clamp Stop Motion Flanged Bushing Pin
462c	773	" " " " " Set Screw.....
3022j	—	Clamp Stop Motion complete, Nos. 248A, 256j, 2020 and 4933.....
20197	2001	Crank Connecting Rod with 20198 and two 896E.....
*20198	—	Crank Connecting Rod Cap.....
896E	773	" " " " Screw.....
908c	773	" " " " Hinge Screw.....
1619E	773	" " " " " Nut
20057	—	Face Plate.....
*44181	—	" " Thread Guard (lower).....
12150	773	" " " " " 44181 with 12152.....
12152	773	Face Plate Thread Guard (lower) Rivet...
2827	773	" " " " (upper) with 8505.....
8505	773	Face Plate Thread Guard (upper) Rivet
20058	5735	Face Plate complete, Nos. 2827, 12150 and 20057.....
190D	782	Face Plate Screw.....
286D	783	" " Thumb Screw.....
12368	767	Feed Bar.....

NO.	PLATE	NAME
313c	783	Feed Bar Screw Centre.....
56813	—	“ “ “ “ 313c with 1519j .
1519j	783	“ “ “ “ Nut.....
3033	770	“ Connecting Link.....
375c	782	“ “ “ “ Hinge Screw.....
1518j	783	“ “ “ “ “ Nut.
44252	5813	“ Dog, for cloth, 12 teeth (12 teeth to the inch).....

NOTE: No. 44252 is sent with this machine unless another Feed Dog is specified on order

44253	5813	Feed Dog, for cloth, 16 teeth (16 teeth to the inch).....
12370	2692	Feed Dog, for cloth, 15 teeth (16 teeth to the inch).....
43979	778	Feed Dog, for cloth, 21 teeth (22 teeth to the inch).....
12425	779	Feed Dog, for cloth, 13 teeth (16 teeth to the inch).....
12450	777	Feed Dog, for cloth, 11 teeth (18 teeth to the inch).....
20348	777	Feed Dog, for chiffon, 22 teeth (36 teeth to the inch).....
20106	1259	Feed Dog, for cloth, 13 teeth (16 teeth to the inch).....
20119	1259	Feed Dog, for heavy work on duck, overalls, etc., 18 teeth (16 teeth to the inch).....
20158	1262	Feed Dog, for shirt work, 17 teeth (16 teeth to the inch).....
20151	1262	Feed Dog, for shirt work, beveled for hemmer, 13 teeth (14 teeth to the inch).....
44144	1262	Feed Dog, for shirt work, beveled for hemmer, 22 teeth (24 teeth to the inch).....
20117	1261	Feed Dog, for shirt work, beveled for hemmer, 16 teeth (16 teeth to the inch).....
20138	1263	Feed Dog, for shirt work, beveled for hemmer, 13 teeth (12 teeth to the inch).....
20162	1263	Feed Dog, for shirt work, beveled for hemmer, 17 teeth (16 teeth to the inch).....
20147	1260	Feed Dog, for shirt work, 12 teeth (14 teeth to the inch).....
12481	778	Feed Dog, for shirt work, 18 teeth (16 teeth to the inch).....
43978	778	Feed Dog, for shirt work, 24 teeth (22 teeth to the inch).....
44136	1381	Feed Dog, for tailor work, 15 teeth (16 teeth to the inch).....

NO.	PLATE	NAME
44156	5837	Feed Dog, for shirt work, 24 teeth (24 teeth to the inch).....
44177	1260	Feed Dog, for shirt work, 19 teeth (22 teeth to the inch).....
208E	782	Feed Dog Screw.....
20283	2020	“ and Feed Lifting Eccentric with 446c
446c	783	“ “ “ “ “ Set Screw
24036	2020	“ “ “ “ “ Sleeve...
20284	2020	“ Forked Connection.....
375c	782	“ “ “ “ “ Hinge Screw....
1518j	783	“ “ “ “ “ Nut
*43993	—	Feed Forked Connection complete, Nos. 818b, 3033, 3039, 20284 and two each 375c and 1518j.....
44125	5804	Feed Lifting Rock Shaft.....
44126	—	Feed Lifting Rock Shaft complete, Nos. 12376 and 44125.....
12376	770	Feed Lifting Rock Shaft Crank with 157j and 1813.....
157j	782	Feed Lifting Rock Shaft Crank Clamping Screw.....
43976	5804	Feed Lifting Rock Shaft Crank Connecting Rod with 43977 and two 966E.....
*43977	—	Feed Lifting Rock Shaft Crank Connecting Rod Cap.....
966E	5806	Feed Lifting Rock Shaft Crank Connecting Rod Cap Screw.....
375c	782	Feed Lifting Rock Shaft Crank Connecting Rod Hinge Screw.....
1518j	783	Feed Lifting Rock Shaft Crank Connecting Rod Hinge Screw Nut.....
1813	783	Feed Lifting Rock Shaft Crank Roller and Stud.....
307c	783	Feed Lifting Rock Shaft Screw Centre....
56814	—	“ “ “ “ “ “ “ 307c with 1513j.....
1513j	783	Feed Lifting Rock Shaft Screw Centre Nut
3039	768	“ Regulator.....
1128E	2009	“ “ “ “ “ Hinge Screw.....
818D	783	“ “ “ “ “ Thumb Screw.....
12379	766	“ Rock Shaft.....
29633	5736	“ “ “ “ “ Crank with 157j.....
157j	782	“ “ “ “ “ Clamping Screw..
20333	—	Feed Rock Shaft complete, Nos. 12379 and 29633.....
307c	783	Feed Rock Shaft Screw Centre.....

NO.	PLATE	NAME
56814	—	Feed Rock Shaft Screw Centre 307c with 1513r.....
1513J	783	Feed Rock Shaft Screw Centre Nut.....
12381	767	Needle Bar (hollow).....
*12382	770	“ “ Connecting Link with 794E...
43997	—	“ “ “ “ 12382 with 12384.....
794E	782	Needle Bar Connecting Link Adjusting Screw.....
*12383	—	Needle Bar Connecting Stud.....
1904	770	“ “ “ “ Roller (roller only).....
453c	783	Needle Bar Connecting Stud Set Screw..
12384	770	Needle Bar Connecting Stud complete, Nos. 453c, 1904 and 12383.....
20188	767	Needle Bar Crank with 858c and 1065c..
1065c	2011	“ “ “ Position Screw.....
858c	783	“ “ “ Set Screw.....
936E	773	“ “ Screw Bushing.....
4302	773	“ “ Thread Guide.....
233D	782	“ “ “ Screw.....
4303	773	“ Clamp with 808F.....
808F	782	“ “ Screw.....
*24104	2001	Oscillating Rock Shaft.....
24105	—	Oscillating Rock Shaft complete, Nos. 4784, 12388 and 24104.....
12388	767	Oscillating Rock Shaft Hinge Pin.....
448c	783	“ “ “ “ Set Screw.....
4784	1353	“ “ “ Oil Pad.....
12389	766	“ Shaft.....
19496	—	“ “ Crank for 19447.....
44134	—	“ “ “ “ 44135.....
2049	773	“ “ “ Pin.....
457c	783	“ “ “ SetScrewfor19447.....
453c	783	“ “ “ “ “ 44135.....
19448	2011	“ “ “ Slide Block.....
226D	1371	“ “ “ “ Cap Screw.....
12424	773	Oscillating Shaft Crank Slide Block Cap Screw Washer.....
988c	2011	Oscillating Shaft Crank Slide Block Screw Stud.....
1518J	783	Oscillating Shaft Crank Slide Block Screw Stud Nut.....
19449	2011	Oscillating Shaft Crank Slide Block complete, Nos. 226D, 988c, 12424 and 19448

NO.	PLATE	NAME
19447	2011	Oscillating Shaft Crank complete, Nos. 457c, 1518J, 19449 and 19496.....
44135	5806	Oscillating Shaft Crank complete, Nos. 1518J, 19449, 44134 and two 453c.....
12391	767	Presser Bar (hollow).....
20059	5736	“ “ Guide Bracket with 453c.....
453c	783	“ “ “ “ Set Screw.....
2062	771	“ “ Lifter.....
689c	782	“ “ “ Screw.....
1520J	783	“ “ “ “ Nut.....
12327	770	“ “ Lifting and Releasing Lever Bracket.....
11167	767	Presser Bar Spring (light) .051 wire.....
NOTE: No. 11167 is sent with this machine unless another Spring is specified on order		
12139	2004	Presser Bar Spring (medium) .055 wire...
20023	2004	“ “ “ (heavy) .063 wire.....
11170	771	“ “ “ Washer.....
12143	780	“ Foot for 12369, 12457 and 20106
NOTE: No. 12143 is sent with this machine unless another Presser Foot is specified on order		
12335	1308	Presser Foot (narrow) for 12369, 12457 and 20106.....
12258	1308	Presser Foot (wide) for 12369, 12457 and 20106.....
12142	780	Presser Foot for 12370 and 43979.....
12259	780	“ “ “ 12425.....
12144	780	“ “ “ 20117, 20138, 20147, 20151, 20158 and 20162.....
12260	780	Presser Foot for 12450, 20147 and 20348...
12474	1308	“ “ “ 20138 and 20162.....
20342	781	“ “ “ 12450 and 20348.....
20343	781	“ “ “ with guide on bottom to the right of needle hole, for 12369, 12450, 12457 and 20348.....
20458	780	Presser Foot for 44136.....
12261	1308	“ “ “ 12481 and 43978.....
12348	5837	“ “ “ outside stays and strips
12311	5837	“ “ “ shirt work.....
12467	781	“ “ “ umbrella work.....
62527	5806	“ “ Hinge Pin.....
24544	—	“ “ Plate.....
24982	—	“ “ Shank.....
26231	2014	“ “ Spring.....



NO.	PLATE	NAME
24983	781	Presser Foot (spring hinged) complete, for 12425 and 20119, Nos. 24544, 24982, 26231 and 62527.....
7298	2014	Presser Foot Hinge Pin.....
19334	—	“ “ Plate.....
19335	—	“ “ Shank.....
19336	1308	Presser Foot (hinged) complete, for 12370 and 43979, Nos. 7298, 19334 and 19335
7298	2014	Presser Foot Hinge Pin.....
20268	—	“ “ Plate.....
20269	—	“ “ Shank.....
20270	1308	Presser Foot (hinged) complete for 12369, 12457 and 20106, Nos. 7298, 20268 and 20269.....
62527	5806	Presser Foot Hinge Pin.....
20310	—	“ “ Plate.....
19223	—	“ “ Shank.....
20311	781	Presser Foot (hinged) complete for 20117, 20138, 20147, 20151, 20158 and 20162, Nos. 19223, 20310 and 62527.....
62527	5806	Presser Foot Hinge Pin.....
20344	—	“ “ Plate.....
20345	—	“ “ Shank.....
26231	2014	“ “ Spring.....
20346	781	Presser Foot (spring hinged) complete for 20117, 20138, 20147, 20151, 20158 and 20162, Nos. 20344, 20345, 26231 and 62527.....
190D	782	Presser Foot Screw.....
688J	783	Pressure Regulating Thumb Screw.....
19131	5737	Shuttle Bobbin.....
20649	5737	“ “ Case Latch.....
2973	5737	“ “ “ “ Lever.....
2974	5737	“ “ “ “ Fulcrum Pin.....
2975	5737	Shuttle Bobbin Case Latch Spring.....
592E	5737	“ “ “ “ Stop Screw...
20650	—	Shuttle Bobbin Case Hinge, Nos. 2973, 2974 and 20649.....
20755	5737	Shuttle Bobbin Case Position Finger.....
2523	5737	“ “ “ “ Rivet.....
24323	2046	“ “ “ “ Plate.....
391D	1366	“ “ “ “ Screw.....
20756	5737	Shuttle Bobbin Case complete, Nos. 591F, 592E, 2523, 2975, 20650, 20654 and 20755.....

NO.	PLATE	NAME
20757	5737	Shuttle Body.....
591F	5737	“ Tension Regulating Screw.....
20654	5737	“ “ Spring.....
20758	5737	Shuttle, 1 $\frac{1}{4}$ in. diam., Nos. 19131, 20756 and 20757.....
19406	2012	Shuttle Driver with two 1266c.....
2049	773	“ “ Pin.....
1266c	5806	“ “ Set Screw.....
2419	2006	“ Race Back.....
2532	772	“ “ “ Position Pin.....
2533	767	“ “ “ Spring.....
907D	782	“ “ “ Screw.....
24324	—	“ “ Body.....
24998	—	“ “ “ 24324 with 24009 and two 1053D.....
24009	2006	Shuttle Race Cap.....
1053D	2006	“ “ “ Screw.....
24325	2046	Shuttle Race complete, Nos. 907D, 2419, 2533, 24323, 24998 and two each 391D and 2532.....
145D	782	Shuttle Race Screw.....
12431	—	“ “ Slide.....
4307	772	“ “ “ Spring.....
725E	1387	“ “ “ Screw.....
12432	2004	Shuttle Race Slide complete, Nos. 4307, 12431 and two 725E.....
20060	5736	Slack Thread Regulator.....
225F	5736	“ “ Adjusting Screw..
2102	5806	Tension Disc.....
1560c	783	“ Regulating Thumb Nut.....
32572	5806	“ Releasing Disc.....
43944	5806	“ “ Lever.....
12398	773	“ “ “ Hinge Pin.....
12329	772	“ “ “ Spring.....
32574	5806	“ “ Pin.....
50327c	5806	“ Screw Stud.....
44141	—	“ “ 50327c with 1560c..
43945	5806	“ Spring.....
44118	—	Tension complete, Nos. 7336, 32572, 32574, 43945, 43946, 44141 and two 2102
52454	5842	Thread Retainer.....
624c	8628	“ “ Set Screw.....
12404	770	“ Take-up Crank.....
3094	773	“ “ “ Wedge.....
690E	782	“ “ “ Screw...
12408	770	“ “ Lever.....
775E	782	“ “ “ Cap Screw.....

NO.	PLATE	NAME
12166	773	Thread Take-up Lever Hinge Pin.....
12409	770	" " " Link.....
11204	770	" " " " Hinge Pin
435c	5806	" " " " " "
		Set Screw.....
12410	—	Thread Take-up Lever complete, Nos. 12166, 12408 and 12409.....
43946	5806	Thread Take-up Spring.....
7336	772	" " " Regulator.....
448c	783	" " " " Set Screw
*43990	—	Thread Take-up complete, Nos. 775e, 11204, 12404, 12410 and 43997.....
44256	—	Throat Plate, large needle hole, for 44252 and 44253.....

NOTE: No. 44256 is sent with this machine unless  
another Throat Plate is specified on order

44255	5813	Throat Plate, small needle hole, for 44252 and 44253.....
12412	778	Throat Plate, small needle hole, for 12370 and 43979.....
12426	779	Throat Plate, small needle hole, for 12425
12466	—	" " " " " " 12425
12464	777	" " large needle hole, for 12450 and 20348.....
12451	2689	Throat Plate, small needle hole, for 12450 and 20348.....
20315	—	Throat Plate, large needle hole, for 20106
20107	1259	" " small needle hole, for 20106
20120	1259	" " large oblong needle hole, for 20119.....
20187	—	Throat Plate, small oblong needle hole, for 20119.....
19497	1261	Throat Plate, large needle hole, for 20117
19405	—	" " small needle hole, for 20117
19409	—	" " large needle hole, for 20138 and 20162.....
19410	1263	Throat Plate, small needle hole, for 20138 and 20162.....
19415	1262	Throat Plate, large needle hole, for 20151 and 44144.....
19416	—	Throat Plate, small needle hole, for 20151 and 44144.....
19418	1262	Throat Plate, large needle hole, for 20158 and 44156.....

NO.	PLATE	NAME
19419	—	Throat Plate, small needle hole, for 20158 and 44156.....
19412	1260	Throat Plate, large needle hole, for 20147 and 44177.....
19413	—	Throat Plate, small needle hole, for 20147 and 44177.....
12482	—	Throat Plate, large needle hole, for 12481 and 43978.....
12483	778	Throat Plate, small needle hole, for 12481 and 43978.....
44137	1381	Throat Plate, large needle hole, for 44136
44138	—	" " small needle hole, for 44136
691F	782	" " Screw.....
44212	5844	Drip Pan with four 1 in. wire nails.....

**SINGER** Needles should be used  
in **SINGER** Machines  
These Needles and their Containers  
are marked with the  
Company's Trade Mark "SIMANCO.\*\*" 1

Needles in Containers marked  
"FOR SINGER MACHINES"  
are NOT **SINGER** made needles. 2

## LIST OF PARTS COMPLETE

FOR

## MACHINE No. 31-22

FOR CLOAKS AND OTHER HEAVY CLOTH WORK. THROAT  
PLATE FLUSH WITH BED. DROP FEED, HIGH LIFT  
PRESSER. BOBBIN No. 19131.

NO.	PLATE	NAME
*12355	—	Arm with 11104.....
8582	773	" Dowel Pin.....
12453	773	" Oil Tube for intermediate bearing...
11119	773	" " " with 52045, for oiling 12408
12454	773	" " " " " " " 12409
24131	2014	" " " " " " " 20283
52045	8628	" " " Packing (braided cotton)
748E	782	" Screw (back).....
854E	783	" " (front).....
12427	766	" Shaft.....
*44122	—	" " 12427 with 20188, 20283 and 24036.....
*44189	—	Arm Shaft 44122 with 20197.....
*11104	—	" " Bushing (front).....
12357	767	" " Flanged Bushing (back)....
448c	783	" " " " " " Set Screw.....
144D	782	Arm Shaft Screw.....
12480	767	" Side Cap.....
219D	774	" " " Screw.....
12193	2004	" " Cover.....
286D	783	" " " Thumb Screw.....
12403	772	" Spool Pin and Thread Eyelet.....
11241	2003	" " " Washer (cloth).....
12358	2000	Balance Wheel (power) light rim, 2 $\frac{1}{8}$ in. pulley with two 448c.....
4370	2000	Balance Wheel (stand) heavy rim, 2 $\frac{3}{4}$ in. pulley, with two 448c.....
2135	2000	Balance Wheel (stand) heavy rim, 2 $\frac{1}{2}$ in. pulley, for 3022.....
2862	—	Balance Wheel (stand) heavy rim, 3 in. pulley, for 3022.....
448c	783	Balance Wheel Set Screw.....
*12360	—	Bed.....
256J	2003	Clamp Stop Motion Clamp Screw.....
248A	2011	" " " " " Stop Screw...
2020	2003	" " " " " Washer.....

NO.	PLATE	NAME
*3023	—	Clamp Stop Motion Flanged Bushing....
4933	2003	" " " " " " 3023 with two 462c.....
2022	773	Clamp Stop Motion Flanged Bushing Pin
462c	773	" " " " " " Set Screw.....
3022J	—	Clamp Stop Motion complete, Nos. 248A, 256J, 2020 and 4933.....
20197	2001	Crank Connecting Rod with 20198 and two 896E.....
*20198	—	Crank Connecting Rod Cap.....
896E	773	" " " " " Screw.....
908c	773	" " " " " Hinge Screw....
1619E	773	" " " " " " Nut
20057	—	Face Plate.....
*44181	—	" " Thread Guard (lower).....
12150	773	" " " " " " 44181 with 12152.....
12152	773	Face Plate Thread Guard (lower) Rivet...
2827	773	" " " " " (upper) with 8505.....
8505	773	Face Plate Thread Guard (upper) Rivet
20058	5735	Face Plate complete, Nos. 2827, 12150 and 20057.....
190D	782	Face Plate Screw.....
286D	783	" " Thumb Screw.....
12368	767	Feed Bar.....
313c	783	" " Screw Centre.....
56813	—	" " " " " 313c with 1519J.
1519J	783	" " " " " Nut.....
3033	770	" Connecting Link.....
375c	782	" " " " " Hinge Screw.....
1518J	783	" " " " " " Nut.
44252	5813	" Dog, 12 teeth (12 teeth to the inch)

NOTE: No. 44252 is sent with this machine, unless  
another Feed Dog is specified on order

44253	5813	Feed Dog, 16 teeth (16 teeth to the inch)
12370	2692	" " 15 teeth (16 teeth to the inch)
44136	1381	" " for tailor work, 15 teeth (16 teeth to the inch).....
208E	782	Feed Dog Screw.....
20283	2020	" and Feed Lifting Eccentric with 446c
446c	783	" " " " " " Set Screw
24036	2020	" " " " " " Sleeve...
20284	2020	" Forked Connection.....
375c	782	" " " " " Hinge Screw....

NO.	PLATE	NAME
1518J	783	Feed Forked Connection Hinge Screw Nut
*43993	—	Feed Forked Connection complete, Nos. 818D, 3033, 3039, 20284 and two each 375c and 1518J.....
44125	5804	Feed Lifting Rock Shaft.....
44126	—	Feed Lifting Rock Shaft complete, Nos. 12376 and 44125.....
12376	770	Feed Lifting Rock Shaft Crank with 157J and 1813.....
157J	782	Feed Lifting Rock Shaft Crank Clamping Screw.....
43976	5804	Feed Lifting Rock Shaft Crank Connecting Rod with 43977 and two 966E.....
*43977	—	Feed Lifting Rock Shaft Crank Connecting Rod Cap.....
966E	5806	Feed Lifting Rock Shaft Crank Connecting Rod Cap Screw.....
375c	782	Feed Lifting Rock Shaft Crank Connecting Rod Hinge Screw.....
1518J	783	Feed Lifting Rock Shaft Crank Connecting Rod Hinge Screw Nut.....
1813	783	Feed Lifting Rock Shaft Crank Roller and Stud.....
307c	783	Feed Lifting Rock Shaft Screw Centre.....
56814	—	“ “ “ “ “ “ 307c with 1513J.....
1513J	783	Feed Lifting Rock Shaft Screw Centre Nut.....
3039	768	“ Regulator.....
1128E	2009	“ “ Hinge Screw.....
818D	783	“ “ Thumb Screw.....
12379	766	“ Rock Shaft.....
29633	5736	“ “ “ Crank with 157J.....
157J	782	“ “ “ “ Clamping Screw.....
20333	—	Feed Rock Shaft complete, Nos. 12379 and 29633.....
307c	783	Feed Rock Shaft Screw Centre.....
56814	—	“ “ “ “ “ “ 307c with 1513J.....
1513J	783	Feed Rock Shaft Screw Centre Nut.....
19229	2004	Needle Bar (hollow) for high lift.....
*12382	770	“ “ Connecting Link with 794E.....
43997	—	“ “ “ “ 12382 with 12384.....
794E	782	Needle Bar Connecting Link Adjusting Screw.....
*12383	—	Needle Bar Connecting Stud.....

NO.	PLATE	NAME
1904	770	Needle Bar Connecting Stud Roller (roller only).....
453c	783	Needle Bar Connecting Stud Set Screw...
12384	770	Needle Bar Connecting Stud complete, Nos. 453c, 1904 and 12383.....
20188	767	Needle Bar Crank with 858c and 1065c....
1065c	2011	“ “ “ Position Screw.....
858c	783	“ “ “ Set Screw.....
936E	773	“ “ Screw Bushing.....
24101	—	“ Clamp Body.....
808F	782	“ “ Screw.....
24102	2011	“ “ Thread Guard.....
651D	2011	“ “ “ “ Screw.....
24103	2011	Needle Clamp (high lift) complete, Nos. 651D, 808F, 24101 and 24102.....
*24104	2001	Oscillating Rock Shaft.....
24105	—	Oscillating Rock Shaft complete, Nos. 4784, 12388 and 24104.....
12388	767	Oscillating Rock Shaft Hinge Pin.....
448c	783	“ “ “ “ “ Set Screw
4784	1353	“ “ “ Oil Pad.....
12389	766	“ Shaft.....
19496	—	“ “ Crank for 19447.....
44134	—	“ “ “ “ 44135.....
2049	773	“ “ “ Pin.....
457c	783	“ “ “ Set Screw for 19447
453c	783	“ “ “ “ “ “ 44135
19448	2011	“ “ “ Slide Block.....
226D	1371	“ “ “ “ “ Cap Screw
12424	773	“ “ “ “ “ “ “ Washer.....
988c	2011	Oscillating Shaft Crank Slide Block Screw Stud.....
1518J	783	Oscillating Shaft Crank Slide Block Screw Stud Nut.....
19449	2011	Oscillating Shaft Crank Slide Block complete, Nos. 226D, 988c, 12424 and 19448
19447	2011	Oscillating Shaft Crank complete, Nos. 457c, 1518J, 19449 and 19496.....
44135	5806	Oscillating Shaft Crank complete, Nos. 1518J, 19449, 44134 and two 453c.....
12391	767	Presser Bar (hollow).....
43917	2009	“ “ Guide Bracket with 453c....
453c	783	“ “ “ “ Set Screw....
5990	2011	“ “ Lifter.....
689c	782	“ “ “ Screw.....
1520J	783	“ “ “ “ Nut.....

NO.	PLATE	NAME
12327	770	Presser Bar Lifting and Releasing Lever Bracket.....
11167	767	Presser Bar Spring (light) .051 wire.....
NOTE: No. 11167 is sent with this machine, unless another Spring is specified on order		
12139	2004	Presser Bar Spring (medium) .055 wire...
20023	2004	" " " (heavy) .063 wire.....
11170	771	" " " Washer.....
12143	780	" " Foot for 12369 and 12457.....
NOTE: No. 12143 is sent with this machine, unless another Presser Foot is specified on order		
12335	1308	Presser Foot (narrow) for 12369 and 12457
12258	1308	" " (wide) for 12369 and 12457..
12142	780	" " for 12370.....
20458	780	" " " 44136.....
7298	2014	" " Hinge Pin.....
20268	—	" " Plate.....
20269	—	" " Shank.....
20270	1308	Presser Foot (hinged) complete for 12369 and 12457, Nos. 7298, 20268 and 20269
7298	2014	Presser Foot Hinge Pin.....
19334	—	" " Plate.....
19335	—	" " Shank.....
19336	1308	Presser Foot (hinged) complete for 12370 and 44136, Nos. 7298, 19334 and 19335
190D	782	Presser Foot Screw.....
688J	783	Pressure Regulating Thumb Screw.....
19131	2012	Shuttle Bobbin.....
20649	2012	" " Case Latch.....
2973	771	" " " " Lever.....
2974	771	" " " " Fulcrum Pin.....
2975	771	Shuttle Bobbin Case Latch Spring.....
592E	782	" " " " Stop Screw..
20650	—	Shuttle Bobbin Case Hinge, Nos. 2973, 2974 and 20649
20755	5737	Shuttle Bobbin Case Position Finger.....
2523	771	" " " " " Rivet
24323	2046	" " " " Plate.....
391D	1366	" " " " " Screw
20756	5737	Shuttle Bobbin Case complete, Nos. 591F, 592E, 2523, 2975, 20650, 20654 and 20755.....
20757	5737	Shuttle Body.....
591F	782	" Tension Regulating Screw.....
20654	2012	" " Spring.....

NO.	PLATE	NAME
20758	5737	Shuttle, 1½ in. diam., Nos. 19131, 20756 and 20757.....
*19406	2012	Shuttle Driver with two 1266c.....
2049	773	" " Pin.....
1266c	5806	" " Set Screw.....
2419	2006	" Race Back.....
2532	772	" " " Position Pin.....
2533	767	" " " Spring.....
907D	782	" " " " Screw.....
24324	—	" " Body.....
24998	—	" " " 24324 with 24009 and two 1053D.....
24009	2006	Shuttle Race Cap.....
1053D	2006	" " " Screw.....
24325	2046	Shuttle Race complete, Nos. 907D, 2419, 2533, 24323, 24998 and two each 391D and 2532.....
145D	782	Shuttle Race Screw.....
12431	—	" " Slide.....
4307	772	" " " Spring.....
725E	1387	" " " " Screw.....
12432	2004	Shuttle Race Slide complete, Nos. 4307, 12431 and two 725E.....
20060	5736	Slack Thread Regulator.....
225F	5736	" " " Adjusting Screw
2102	5806	Tension Disc.....
1560c	783	" Regulating Thumb Nut.....
32572	5806	" Releasing Disc.....
43980	5837	" " Lever.....
12398	773	" " " Hinge Pin.....
12329	772	" " " Spring.....
32574	5806	" " Pin.....
50327c	5806	" Screw Stud.....
44141	—	" " " 50327c with 1560c...
43945	5806	" Spring.....
44118	—	Tension complete, Nos. 7336, 32572, 32574, 43945, 48946, 44141 and two 2102
52454	5842	Thread Retainer.....
624c	8628	" " Set Screw.....
43947	5736	" Take-up Crank.....
3094	773	" " " Wedge.....
690E	782	" " " " Screw.....
12408	770	" " Lever.....
775E	782	" " " Cap Screw.....
12166	773	" " " Hinge Pin.....
12409	770	" " " Link.....
11204	770	" " " " Hinge Pin

NO.	PLATE	NAME
435c	5806	Thread Take-up Lever Link Hinge Pin Set Screw.....
12410	—	Thread Take-up Lever complete, Nos. 12166, 12408 and 12409.....
43946	5806	Thread Take-up Spring.....
7336	772	" " " Regulator.....
448c	783	" " " " Set Screw.....
*43991	—	Thread Take-up complete, Nos. 775E, 11204, 12410, 43947 and 43997.....
44256	—	Throat Plate, large needle hole, for 44254.....

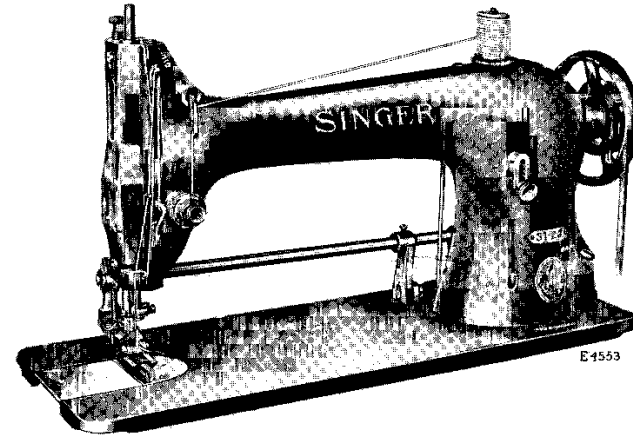
NOTE: Two No. 44256 are sent with this machine, unless other Throat Plates are specified on order

44255	5813	Throat Plate, small needle hole, for 44254.....
12412	778	" " large needle hole, for 12370.....
44137	1381	" " " " " " 44136.....
44138	—	" " small needle hole, for 44136.....
691F	782	" " Screw.....
44212	5844	Drip Pan, with four 1 in. wire nails, for power table.....

**SINGER** Needles should be used  
in **SINGER** Machines  
These Needles and their Containers  
are marked with the  
Company's Trade Mark "SIMANCO.\*\*" 1

Needles in Containers marked  
"FOR SINGER MACHINES"  
are NOT **SINGER** made needles. 2

## LIST OF PARTS COMPLETE FOR



E4553

## MACHINE No. 31-24

**FOR SHADE WORK, SEAMING AND FELLING FABRICS, ETC.  
HAS RECIPROCATING SLIDE ABOVE THE WORK UNDER  
THE PRESSER FOOT. DROP FEED. BOBBIN No. 19131.**

NO.	PLATE	NAME
*20236	—	Arm with 11104.....
8582	773	" Dowel Pin.....
12453	773	" Oil Tube for intermediate bearing...
11119	773	" " " with 52045, for oiling 12408.....
12454	773	" " " " " " " " 12409.....
24131	2014	" " " " " " " " 20283.....
52045	8628	" " " Packing (braided cotton).....
748E	782	" Screw (back).....
854E	783	" " (front).....
12427	766	" Shaft.....
*44122	—	" " 12427 with 20188, 20283 and 24036.....
*44189	—	Arm Shaft 44122 with 20197.....
*11104	—	" " Bushing (front).....
12357	767	" " Flanged Bushing (back)....
448c	783	" " " " " " Set Screw.....

NO.	PLATE	NAME
144D	782	Arm Shaft Screw.....
12480	767	" Side Cap.....
219D	774	" " " Screw.....
12193	2004	" " " Cover.....
286D	783	" " " Thumb Screw.....
12403	772	" Spool Pin and Thread Eyelet.....
11241	2003	" " " Washer (cloth).....
12358	2000	Balance Wheel (power) light rim, 2 $\frac{1}{8}$ in. pulley, with two 448c.....
4370	2000	Balance Wheel (stand) heavy rim, 2 $\frac{1}{4}$ in. pulley, with two 448c.....
2135	2000	Balance Wheel (stand) heavy rim, 2 $\frac{1}{2}$ in. pulley, for 3022.....
2862	—	Balance Wheel (stand) heavy rim, 3 in. pulley, for 3022.....
448c	783	Balance Wheel Set Screw.....
*20237	—	Bed.....
256J	2003	Clamp Stop Motion Clamp Screw.....
248A	2011	" " " " Stop Screw.....
2020	2003	" " " " Washer.....
*3023	—	" " " Flanged Bushing.....
4933	2003	" " " " 3023 with two 462c.....
2022	773	Clamp Stop Motion Flanged Bushing Pin
462c	773	" " " " " Set Screw.....
3022J	—	Clamp Stop Motion complete, Nos. 248A, 256J, 2020 and 4933.....
20197	2001	Crank Connecting Rod with 20198 and two 896E.....
*20198	—	Crank Connecting Rod Cap.....
896E	773	" " " " Screw.....
908c	773	" " " " Hinge Screw.....
1619E	773	" " " " " Nut
20057	—	Face Plate.....
*44181	—	" " Thread Guard (lower).....
12150	773	" " " " " 44181 with 12152.....
12152	773	Face Plate Thread Guard (lower) Rivet
2827	773	" " " " " (upper) with 8505.....
8505	773	Face Plate Thread Guard (upper) Rivet
20058	5735	Face Plate complete, Nos. 2827, 12150 and 20057.....
190D	782	Face Plate Screw.....
286D	783	" " Thumb Screw.....
12368	767	Feed Bar.....

NO.	PLATE	NAME
313c	783	Feed Bar Screw Centre.....
56813	—	" " " " 313c with 1519J..
1519J	783	" " " " Nut.....
3033	770	" Connecting Link.....
375c	782	" " " Hinge Screw.....
1518J	783	" " " " " Nut.
20138	1263	" Dog, 13 teeth (12 teeth to the inch) for shirt work, beveled for hemmer....
NOTE: No. 20138 is sent with this machine, unless another Feed Dog is specified on order		
20162	1263	Feed Dog, 17 teeth (16 teeth to the inch) for shirt work, beveled for hemmer....
208E	782	Feed Dog Screw.....
20283	2020	" and Feed Lifting Eccentric with 446c
446c	783	" " " " " Set Screw
24036	2020	" " " " " Sleeve....
20284	2020	" Forked Connection.....
375c	782	" " " " Hinge Screw....
1518J	783	" " " " " Nut
*43993	—	Feed Forked Connection complete, Nos. 818D, 3033, 3039, 20284 and two each 375c and 1518J.....
44125	5804	Feed Lifting Rock Shaft.....
44126	—	Feed Lifting Rock Shaft complete, Nos. 12376 and 44125.....
12376	770	Feed Lifting Rock Shaft Crank with 157J and 1813.....
157J	782	Feed Lifting Rock Shaft Crank Clamping Screw.....
43976	5804	Feed Lifting Rock Shaft Crank Connecting Rod with 43977 and two 966E....
*43977	—	Feed Lifting Rock Shaft Crank Connecting Rod Cap.....
966E	5806	Feed Lifting Rock Shaft Crank Connecting Rod Cap Screw.....
375c	782	Feed Lifting Rock Shaft Crank Connecting Rod Hinge Screw.....
1518J	783	Feed Lifting Rock Shaft Crank Connecting Rod Hinge Screw Nut.....
1813	783	Feed Lifting Rock Shaft Crank Roller and Stud.....
307c	783	Feed Lifting Rock Shaft Screw Centre....
56814	—	" " " " " " 307c with 1513J.....
1513J	783	Feed Lifting Rock Shaft Screw Centre Nut
3039	768	" Regulator.....

NO.	PLATE	NAME
1128E	2009	Feed Regulator Hinge Screw.....
818D	783	" " Thumb Screw.....
20238	2000	" Rock Shaft.....
29633	5736	" " " Crank with 157J.....
157J	782	" " " " Clamping Screw
20334	—	Feed Rock Shaft complete, Nos. 20238, 20247 and 29633.....
307C	783	Feed Rock Shaft Screw Centre.....
56814	—	" " " " " 307C with 1513J.....
1513J	783	Feed Rock Shaft Screw Centre Nut.....
19229	2004	Needle Bar (hollow) for high lift.....
*12382	770	" " Connecting Link with 794E..
43997	—	" " " " 12382 with 12384.....
794E	782	Needle Bar Connecting Link Adjusting Screw.....
*12383	—	Needle Bar Connecting Stud.....
1904	770	" " " " Roller (roller only).....
453C	783	Needle Bar Connecting Stud Set Screw..
12384	770	Needle Bar Connecting Stud complete, Nos. 453C, 1904 and 12383.....
20188	767	Needle Bar Crank with 858C and 1065C....
1065C	2011	" " " Position Screw.....
858C	783	" " " Set Screw.....
936E	773	" " Screw Bushing.....
24101	—	" Clamp Body.....
808F	782	" " Screw.....
24102	2011	" " Thread Guard.....
651D	2011	" " " " Screw.....
24103	2011	Needle Clamp (high lift) complete, Nos. 651D, 808F, 24101 and 24102.....
*24104	2001	Oscillating Rock Shaft.....
24105	—	Oscillating Rock Shaft complete, Nos. 4784, 12388 and 24104.....
12388	767	Oscillating Rock Shaft Hinge Pin.....
448C	783	" " " " " Set Screw
4784	1353	" " " " Oil Pad.....
12389	766	" Shaft.....
19496	—	" " Crank for 19447.....
44134	—	" " " " 44135.....
2049	773	" " " Pin.....
457C	783	" " " Set Screw for 19447
453C	783	" " " " " 44135
19448	2011	" " " Slide Block.....

NO.	PLATE	NAME
226D	1371	Oscillating Shaft Crank Slide Block Cap Screw.....
12424	773	Oscillating Shaft Crank Slide Block Cap Screw Washer.....
988C	2011	Oscillating Shaft Crank Slide Block Screw Stud.....
1518J	783	Oscillating Shaft Crank Slide Block Screw Stud Nut.....
19449	2011	Oscillating Shaft Crank Slide Block com- plete, Nos. 226D, 988C, 12424 and 19448
19447	2011	Oscillating Shaft Crank complete, Nos. 457C, 1518J, 19449 and 19496.....
44135	5806	Oscillating Shaft Crank complete, Nos. 1518J, 19449, 44134 and two 453C....
12391	767	Presser Bar (hollow).....
20059	5736	" " Guide Bracket with 453C....
453C	783	" " " " Set Screw....
20240	2019	" " Lifter.....
689C	782	" " Screw.....
1520J	783	" " " " Nut.....
12327	770	" " Lifting and Releasing Lever Bracket.....
11167	767	Presser Bar Spring (light) .051 wire.....
NOTE: No. 11167 is sent with this machine, unless another Spring is specified on order		
12139	2004	Presser Bar Spring (medium) .055 wire...
20023	2004	" " " (heavy) .063 wire....
11170	771	" " " Washer.....
20241	—	" Foot Body.....
20242	2019	" " Roller.....
131D	2019	" " " Screw.....
1550J	783	" " " " Nut.....
20243	2019	Presser Foot (roller) complete, Nos. 131D, 1550J, 20241 and 20242.....
190D	782	Presser Foot Screw.....
688J	783	Pressure Regulating Thumb Screw.....
20244	2019	Reciprocating Spring Presser Blade.....
20347	2048	" " " " (slotted)
20245	2019	" " " " Holder
1099F	2019	" " " " "
Hinge Screw.....		
233D	782	Reciprocating Spring Presser Blade Screw
9804	2019	" " " " Spring
20246	2019	" " " " "
Bracket.....		



NO.	PLATE	NAME
7483	2019	Reciprocating Spring Presser Blade Spring Hook.....
20247	2020	Reciprocating Spring Presser Regulator Crank with 1518J, 1942 and two 190D..
190D	782	Reciprocating Spring Presser Regulator Crank Clamping Screw.....
1904	770	Reciprocating Spring Presser Regulator Crank Roller (roller only).....
229D	782	Reciprocating Spring Presser Regulator Crank Roller Cap Screw.....
12424	773	Reciprocating Spring Presser Regulator Crank Roller Cap Screw Washer.....
1942	2019	Reciprocating Spring Presser Regulator Crank Roller and Screw Stud with 229D, 1904 and 12424.....
1518J	783	Reciprocating Spring Presser Regulator Crank Roller and Screw Stud Nut.....
20248	2000	Reciprocating Spring Presser Shaft.....
20249	2020	" " " " Bracket (back).....
134D	2019	Reciprocating Spring Presser Shaft Bracket (back) Screw.....
20250	2020	Reciprocating Spring Presser Shaft Bracket (front).....
190D	782	Reciprocating Spring Presser Shaft Bracket (front) Screw.....
20251	2019	Reciprocating Spring Presser Shaft Collar with 456C.....
456C	773	Reciprocating Spring Presser Shaft Collar Set Screw.....
20254	2020	Reciprocating Spring Presser Shaft Crank (back) with 191F.....
2049	773	Reciprocating Spring Presser Shaft Crank (back) Pin.....
191F	2019	Reciprocating Spring Presser Shaft Crank (back) Set Screw.....
20252	2019	Reciprocating Spring Presser Shaft Crank (front) with 7483 and two 453C.....
20253	—	Reciprocating Spring Presser Shaft Crank (front) complete, No. 1099F, 9804, 20244 to 20246, 20252 and two 233D...
453C	783	Reciprocating Spring Presser Shaft Crank (front) Set Screw.....
19131	2012	Shuttle Bobbin.....
20649	2012	" " Case Latch.....
2973	771	" " " " Lever.....

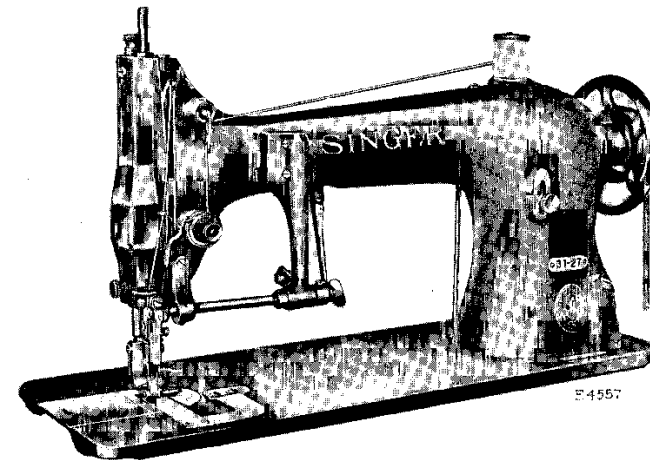
NO.	PLATE	NAME
2974	771	Shuttle Bobbin Case Latch Lever Fulcrum Pin.....
2975	771	Shuttle Bobbin Case Latch Spring.....
592B	782	" " " " Stop Screw...
20650	—	Shuttle Bobbin Case Hinge, Nos. 2973, 2974 and 20649.....
20755	5737	Shuttle Bobbin Case Position Finger.....
2523	771	" " " " " Rivet
24323	2046	" " " " Plate.....
391D	1366	" " " " " Screw
20756	5737	Shuttle Bobbin Case complete, Nos. 591F, 592E, 2523, 2975, 20650, 20654 and 20755.....
20757	5737	Shuttle Body.....
591F	782	" Tension Regulating Screw.....
20654	2012	" " Spring.....
20758	5737	Shuttle, 1 1/4 in. diam., Nos. 19131, 20756 and 20757.....
19406	2012	Shuttle Driver with two 1266C.....
2049	773	" " Pin.....
1266C	5806	" " Set Screw.....
2419	2006	" Race Back.....
2532	772	" " " Position Pin.....
2533	767	" " " Spring.....
907D	782	" " " " Screw.....
24324	—	" " Body.....
24998	—	" " " 24324 with 24009 and two 1053D.....
24009	2006	Shuttle Race Cap.....
1053D	2006	" " " Screw.....
24325	2046	Shuttle Race complete, Nos. 907D, 2419, 2533, 24323, 24998 and two each 391D and 2532.....
145D	782	Shuttle Race Screw.....
12431	—	" " Slide.....
4307	772	" " " Spring.....
725E	1387	" " " " Screw.....
12432	2004	Shuttle Race Slide complete, Nos. 4307, 12431 and two 725E.....
20060	5736	Slack Thread Regulator.....
225F	5736	" " " Adjusting Screw
2102	5806	Tension Disc.....
1560C	783	" Regulating Thumb Nut.....
32572	5806	" Releasing Disc.....
43944	5806	" " Lever.....
12398	773	" " " Hinge Pin.....
12329	772	" " " Spring.....

NO.	PLATE	NAME
32574	5806	Tension Releasing Pin.....
50327c	5806	" Screw Stud.....
44141	—	" " " 50327c with 1560c...
43945	5806	" Spring.....
44118	—	Tension complete, Nos. 7336, 32572, 32574, 43945, 43946, 44141 and two 2102
52454	5842	Thread Retainer.....
624c	8628	" " Set Screw.....
12404	770	" Take-up Crank.....
3094	773	" " Wedge.....
690E	782	" " " " Screw....
12408	770	" " Lever.....
775E	782	" " Cap Screw.....
12166	773	" " Hinge Pin.....
12409	770	" " Link.....
11204	770	" " " Hinge Pin ..
435c	5806	" " " " " Set Screw.....
12410	—	Thread Take-up Lever complete, Nos. 12166, 12408 and 12409.....
43946	5806	Thread Take-up Spring.....
7336	772	" " " Regulator .....
448c	783	" " " " Set Screw
*43990	—	Thread Take-up complete, Nos. 775E, 11204, 12404, 12410 and 43997.....
19409	—	Throat Plate, large needle hole, for 20138 and 20162.....

NOTE: Two No. 19409 are sent with this machine, unless other Throat Plates are specified on order

19410	1263	Throat Plate, small needle hole, for 20138 and 20162.....
691F	782	Throat Plate Screw.....
44212	5844	Drip Pan with four 1 in. wire nails, for power table.....

## LIST OF PARTS COMPLETE FOR



## MACHINE No. 31-27

FOR FULL OR SCANT RUFFLES ON THICK OR THIN FABRICS,  
FOR APRONS, DRESSES, INFANTS' GARMENTS, SKIRTS,  
ETC. POSITIVE RUFFLING MECHANISM, DROP FEED.  
BOBBIN No. 2996.

NO.	PLATE	NAME
*20312	—	Arm with 11104.....
8582	773	" Dowel Pin.....
12453	773	" Oil Tube for intermediate bearing...
11119	773	" " " with 52045, for oiling 12408 and 24207.....
12454	773	Arm Oil Tube with 52045, for oiling 12409
24131	2014	" " " " " " 20283
52045	8628	" " " Packing (braided cotton)..
748E	782	" Screw (back).....
854E	783	" " (front).....
20332	2049	" Shaft.....
*44130	—	" " 20332 with 20188, 20283, 24036, 24207 and 24208.....
*44207	—	Arm Shaft 44130 with 20197.....
*11104	—	" " Bushing (front).....

NO.	PLATE	NAME
12357	767	Arm Shaft Flanged Bushing (back).....
448c	783	" " " " " " Set Screw.....
144d	782	Arm Shaft Screw.....
12480	767	" Side Cap.....
219d	774	" " " Screw.....
12193	2004	" " Cover.....
286d	783	" " " Thumb Screw.....
12403	772	" Spool Pin and Thread Eyelet.....
11241	2003	" " " Washer (cloth).....
12358	2000	Balance Wheel (power) light rim, 2 $\frac{1}{8}$ in. pulley with two 448c.....
4370	2000	Balance Wheel (stand) heavy rim, 2 $\frac{3}{4}$ in. pulley, with two 448c.....
2135	2000	Balance Wheel (stand) heavy rim, 2 $\frac{1}{2}$ in. pulley, for 3022.....
2862	—	Balance Wheel (stand) heavy rim, 3 in. pulley, for 3022.....
448c	783	Balance Wheel Set Screw.....
*12360	—	Bed.....
256j	2003	Clamp Stop Motion Clamp Screw.....
248A	2011	" " " " Stop Screw...
2020	2003	" " " " Washer.....
*3023	—	" " " Flanged Bushing....
4933	2003	" " " " 3023 with two 462c.....
2022	773	Clamp Stop Motion Flanged Bushing Pin
462c	773	" " " " " " Set Screw.....
3022j	—	Clamp Stop Motion complete, Nos. 248A, 256j, 2020 and 4933.....
20197	2001	Crank Connecting Rod with 20198 and two 896E.....
*20198	—	Crank Connecting Rod Cap.....
896E	773	" " " " Screw.....
908c	773	" " " " Hinge Screw.....
1619E	773	" " " " " " Nut
20057	—	Face Plate.....
*44181	—	" " Thread Guard (lower).....
12150	773	" " " " " " 44181 with 12152.....
12152	773	Face Plate Thread Guard (lower) Rivet...
2827	773	" " " " (upper) with 8505.....
8505	773	Face Plate Thread Guard (upper) Rivet..
20058	5735	Face Plate complete, Nos. 2827, 12150 and 20057.....

NO.	PLATE	NAME
190d	782	Face Plate Screw.....
286d	783	" " Thumb Screw.....
12368	767	Feed Bar.....
313c	783	" " Screw Centre.....
56813	—	" " " " 313c with 1519j..
1519j	783	" " " " Nut.....
3033	770	" Connecting Link.....
375c	782	" " " Hinge Screw.....
1518j	783	" " " " " Nut.
24303	1344	" Dog, 6 teeth (14 teeth to the inch)...
208E	782	" " Screw.....
20283	2020	" and Feed Lifting Eccentric with 446c
446c	783	" " " " " Set Screw
24036	2020	" " " " " Sleeve....
20284	2020	" Forked Connection.....
375c	782	" " " Hinge Screw.....
1518j	783	" " " " " Nut
*43993	—	Feed Forked Connection complete, Nos. 818d, 3033, 3039, 20284 and two each 375c and 1518j.....
44125	5804	Feed Lifting Rock Shaft.....
44126	—	Feed Lifting Rock Shaft complete, Nos. 12376 and 44125.....
12376	770	Feed Lifting Rock Shaft Crank with 157j and 1813.....
157j	782	Feed Lifting Rock Shaft Crank Clamping Screw.....
43976	5804	Feed Lifting Rock Shaft Crank Connect- ing Rod with 43977 and two 966E.....
*43977	—	Feed Lifting Rock Shaft Crank Connect- ing Rod Cap.....
966E	5806	Feed Lifting Rock Shaft Crank Connect- ing Rod Cap Screw.....
375c	782	Feed Lifting Rock Shaft Crank Connect- ing Rod Hinge Screw.....
1518j	783	Feed Lifting Rock Shaft Crank Connect- ing Rod Hinge Screw Nut.....
1813	783	Feed Lifting Rock Shaft Crank Roller and Stud.....
307c	783	Feed Lifting Rock Shaft Screw Centre...
56814	—	" " " " " " 307c with 1513j.....
1513j	783	Feed Lifting Rock Shaft Screw Centre Nut
3039	768	" Regulator.....
1128E	2009	" " Hinge Screw.....
818d	783	" " Thumb Screw.....
12379	766	" Rock Shaft.....

NO.	PLATE	NAME
29633	5736	Feed Rock Shaft Crank with 157j.....
157j	782	" " " " Clamping Screw
20333	—	Feed Rock Shaft complete, Nos. 12379 and 29633.....
307c	783	Feed Rock Shaft Screw Centre.....
56814	—	" " " " " 307c with 1513j.....
1513j	783	Feed Rock Shaft Screw Centre Nut.....
12381	767	Needle Bar (hollow).....
*12382	770	" " Connecting Link with 794E....
43997	—	" " " " 12382 with 12384.....
794E	782	Needle Bar Connecting Link Adjusting Screw.....
*12383	—	Needle Bar Connecting Stud.....
1904	770	" " " " Roller (roller only).....
453c	783	Needle Bar Connecting Stud Set Screw...
12384	770	Needle Bar Connecting Stud complete, Nos. 453c, 1904 and 12383.....
20188	767	Needle Bar Crank with 858c and 1065c....
1065c	2011	" " " Position Screw.....
858c	783	" " " Set Screw.....
936E	773	" " Screw Bushing.....
4302	773	" " Thread Guide.....
233D	782	" " " " Screw.....
4303	773	" Clamp with 808F.....
808F	782	" " Screw.....
*24104	2001	Oscillating Rock Shaft.....
24105	—	Oscillating Rock Shaft complete, Nos. 4784, 12388 and 24104.....
12388	767	Oscillating Rock Shaft Hinge Pin.....
448c	783	" " " " Set Screw
4784	1353	" " " Oil Pad.....
12389	766	" Shaft.....
19496	—	" " Crank for 19447.....
44134	—	" " " " 44135.....
2049	773	" " " Pin.....
457c	783	" " " Set Screw for 19447
453c	783	" " " " " 44135
19448	2011	" " " Slide Block.....
226D	1371	" " " " " Cap Screw.....
12424	773	Oscillating Shaft Crank Slide Block Cap Screw Washer.....
988c	2011	Oscillating Shaft Crank Slide Block Screw Stud.....

NO.	PLATE	NAME
1518j	783	Oscillating Shaft Crank Slide Block Screw Stud Nut.....
19449	2011	Oscillating Shaft Crank Slide Block complete, Nos. 226D, 988c, 12424 and 19448
19447	2011	Oscillating Shaft Crank complete, Nos. 457c, 1518j, 19449 and 19496.....
44135	5806	Oscillating Shaft Crank complete, Nos. 1518j, 19449, 44134 and two 453c.....
12391	767	Presser Bar (hollow).....
20059	5736	" " Guide Bracket with 453c....
453c	783	" " " " Set Screw....
2062	771	" " Lifter.....
689c	782	" " " Screw.....
1520j	783	" " " " Nut.....
12327	770	" " Lifting and Releasing Lever Bracket.....
11167	767	Presser Bar Spring (light) .051 wire.....
NOTE: No. 11167 is sent with this Machine, unless another Spring is specified on order		
12139	2004	Presser Bar Spring (medium) .055 wire...
20023	2004	" " " (heavy) .063 wire.....
11170	771	" " " Washer.....
24304	1344	" Foot.....
190D	782	" " Screw.....
688j	783	Pressure Regulating Thumb Screw.....
26888	1344	Ruffling Arm (lower).....
26889	1344	" " (upper) with 190D and 219F
207F	1344	" " Adjusting Screw.....
2291	1344	" " " " Washer...
190D	782	" " Clamping Screw.....
219F	774	" " Set Screw.....
26890	1344	Ruffling Arm (adjustable) Nos. 2291, 26888, 26889 and two 207F.....
28845	—	Ruffling Arm (adjustable) complete, Nos. 226D, 1550H, 24203 to 24206, 26890 and two 665D.....
24199	1323	Ruffling Arm Shaft.....
24201	1324	" " " Bracket (left).....
159D	1324	" " " " " Screw..
24200	1324	" " " " (right).....
145D	1324	" " " " " Screw
6533	1323	" " " Collar with 460c.....
460c	1323	" " " " Set Screw.....
24305	1344	" Blade.....
24203	1344	" " Holder.....
226D	1344	" " " Cap Screw.....

NO.	PLATE	NAME
24579	2014	Ruffling Blade Holder Spring (heavy left)
24581	2014	" " " " (light left) ..
24580	2014	" " " " (heavy right)
24204	1344	" " " " (light right)
24582	1344	" " " " (left stop) ..
24205	1344	" " " " (right stop)
24206	1344	" " " Stud .....
1550H	1344	" " " " Nut .....
665D	1344	" " " Screw .....
24207	1323	" Eccentric with two 453c .....
24208	1323	" " Collar with 453c .....
453C	1323	" " " Set Screw .....
24219	1323	" " " Connection with 24220 and two 742E .....
*24220	—	Ruffling Eccentric Connection Cap .....
742E	1323	" " " " Screw .....
24210	1324	" " " Washer .....
453C	1323	" " " Set Screw .....
24211	1323	" Regulator with 225F .....
225F	1323	" " " Set Screw .....
181D	1323	" " " Stop Screw .....
1641E	1323	" " " Nut .....
1108F	1323	" " " Thumb Screw .....
1641E	1323	" " " " Nut .....
43918	5757	" Separating Blade .....
26092	2671	" " " Rivet .....
43919	5757	" " " Shank .....
43920	5757	Ruffling Separating Blade on Shank complete, Nos. 43918, 43919 and two 26092
1423D	5742	Ruffling Separating Blade Screw .....
2996	771	Shuttle Bobbin .....
62739	—	" " Case .....
15140	2013	" " " Latch .....
2973	771	" " " Lever .....
2974	771	" " " " Fulcrum Pin .....
2975	771	Shuttle Bobbin Case Latch Spring .....
592E	782	" " " " Stop Screw .....
15141	—	Shuttle Bobbin Case Hinge, Nos. 2973, 2974 and 15140 .....
7553	771	Shuttle Bobbin Case Position Finger .....
2523	771	" " " " Rivet .....
24412	1361	" " " " Plate .....
391D	1366	" " " " Screw .....
62740	771	Shuttle Bobbin Case complete, Nos. 591F, 592E, 2523, 2975, 7553, 15141, 15278 and 62739 .....

NO.	PLATE	NAME
12393	771	Shuttle Body .....
591F	782	" Tension Regulating Screw .....
15278	771	" " Spring .....
19292	771	Shuttle, 1 $\frac{1}{8}$ in. diam., Nos. 2996, 12393 and 62740 .....
*12394	—	Shuttle Driver .....
12444	771	" " 12394 with two 1266c .....
2049	773	" " Pin .....
1266C	5806	" " Set Screw .....
2531	767	" Race Back .....
2532	772	" " " Position Pin .....
2533	767	" " " Spring .....
907D	782	" " " Screw .....
24413	—	" " Body .....
25000	—	" " " 24413 with 24414 and two 1053D .....
24414	5837	Shuttle Race Cap .....
1053D	2006	" " " Screw .....
24415	1361	Shuttle Race complete, Nos. 907D, 2531, 2533, 24412, 25000 and two each 391D and 2532 .....
145D	782	Shuttle Race Screw .....
12431	—	" " Slide .....
4307	772	" " " Spring .....
725E	1387	" " " Screw .....
12432	2004	Shuttle Race Slide complete, Nos. 4307, 12431 and two 725E .....
44009	5840	Slack Thread Regulator .....
225F	5736	" " " Adjusting Screw .....
2102	5806	Tension Disc .....
1560C	783	" Regulating Thumb Nut .....
32572	5806	" Releasing Disc .....
43944	5806	" " Lever .....
12398	773	" " " Hinge Pin .....
12329	772	" " " Spring .....
32574	5806	" " Pin .....
50327C	5806	" Screw Stud .....
44141	—	" " " 50327c with 1560c .....
43945	5806	" Spring .....
44118	—	" complete, Nos. 7336, 32572, 32574, 43945, 43946, 44141 and two 2102
52454	5842	Thread Retainer .....
624C	8628	" " Set Screw .....
12404	770	" Take-up Crank .....
3094	773	" " " Wedge .....
690E	782	" " " " Screw .....
12408	770	" " Lever .....

NO.	PLATE	NAME
775E	782	Tension Take-up Lever Cap Screw.....
12166	773	" " " Hinge Pin.....
12409	770	" " " Link.....
11204	770	" " " " Hinge Pin....
435c	5806	" " " " " " " Set Screw.....
12410	—	Thread Take-up Lever complete, Nos. 12166, 12408 and 12409.....
43946	5806	Thread Take-up Spring.....
7336	772	" " " Regulator.....
448c	783	" " " " " Set Screw
*43990	—	Thread Take-up complete, Nos. 775E, 11204, 12404, 12410 and 43997.....
24306	1344	Throat Plate for 24303.....
691F	782	" " Screw.....
44212	5844	Drip Pan with four 1 in. wire nails, for power table.....

**SINGER** Needles should be used  
in **SINGER** Machines  
These Needles and their Containers  
are marked with the  
Company's Trade Mark "**SIMANCO**."\*\* 1

Needles in Containers marked  
"**FOR SINGER MACHINES**"  
are **NOT SINGER** made needles. 2

## LIST OF PARTS COMPLETE FOR MACHINE No. 31-32

FOR CLOTH. HAS REVERSIBLE DROP FEED. BOBBIN No. 2996

NO.	PLATE	NAME
*20313	—	Arm with 11104.....
8582	773	" Dowel Pin.....
12453	773	" Oil Tube for intermediate bearing...
11119	773	" " " with 52045, for oiling 12408
12454	773	" " " " " " " 12409
24131	2014	" " " " " " " 12197
52045	8628	" " " Packing (braided cotton)..
748E	782	" Screw (back).....
854E	783	" " (front).....
12427	766	" Shaft.....
*44124	—	" " 12427 with 12197 and 20188..
*44197	—	" " 44124 with 20197.....
*11104	—	" " Bushing (front).....
12357	767	" " Flanged Bushing (back)....
448c	783	" " " " " " " Set Screw.....
144D	782	Arm Shaft Screw.....
12480	767	" Side Cap.....
219D	774	" " " Screw.....
12193	2004	" " Cover.....
286D	783	" " " Thumb Screw.....
12403	772	" Spool Pin and Thread Eyelet.....
11241	2003	" " " Washer (cloth).....
12358	2000	Balance Wheel (power) light rim, 2 $\frac{1}{8}$ in. pulley, with two 448c.....
4370	2000	Balance Wheel (stand) heavy rim, 2 $\frac{3}{4}$ in. pulley, with two 448c.....
2135	2000	Balance Wheel (stand) heavy rim, 2 $\frac{1}{2}$ in. pulley, for 3022.....
2862	—	Balance Wheel (stand) heavy rim, 3 in. pulley, for 3022.....
448c	783	Balance Wheel Set Screw.....
*12360	—	Bed.....
256J	2003	Clamp Stop Motion Clamp Screw.....
248A	2011	" " " " Stop Screw...
2020	2003	" " " " Washer.....
*3023	—	" " " Flanged Bushing....
4933	2003	" " " " " 3023 with two 462c.....

NO.	PLATE	NAME
2022	773	Clamp Stop Motion Flanged Bushing Pin
462c	773	" " " " " Set
		Screw.....
3022j	—	Clamp Stop Motion complete, Nos. 248A, 256j, 2020 and 4933.....
20197	2001	Crank Connecting Rod with 20198 and two 896E.....
*20198	—	Crank Connecting Rod Cap.....
896E	773	" " " " Screw.....
908c	773	" " " " Hinge Screw....
1619E	773	" " " " " Nut
20057	—	Face Plate.....
44181	—	" " Thread Guard (lower).....
12150	773	" " " " " 44181 with 12152.....
12152	773	Face Plate Thread Guard (lower) Rivet...
2827	773	" " " " (upper) with 8505.....
8505	773	Face Plate Thread Guard (upper) Rivet..
20058	5735	Face Plate complete, Nos. 2827, 12150 and 20057.....
190D	782	Face Plate Screw.....
286D	783	" " Thumb Screw.....
12368	767	Feed Bar.....
313c	783	" " Screw Centre.....
56813	—	" " " " 313c with 1519j..
1519j	783	" " " " Nut.....
12197	2001	" Cam and Feed Lifting Eccentric with 446c.....
446c	783	Feed Cam and Feed Lifting Eccentric Set Screw.....
3033	770	Feed Connecting Link.....
375c	782	" " " " Hinge Screw....
1518j	783	" " " " " Nut..
20304	778	" Dog, 13 teeth (12 teeth to the inch)

NOTE: No. 20304 is sent with this machine, unless  
another Feed Dog is specified on order

44254	5813	Feed Dog, 12 teeth (12 teeth to the inch)
208E	782	" " Screw.....
44003	5840	" Forked Connection.....
*43992	—	Feed Forked Connection complete, Nos. 3033, 12332, 44003 and two each 375c and 1518j.....
375c	782	Feed Forked Connection Hinge Screw....
1518j	783	" " " " " Nut
44125	5804	" Lifting Rock Shaft.....

NO.	PLATE	NAME
44126	—	Feed Lifting Rock Shaft complete, Nos. 12376 and 44125.....
12376	770	Feed Lifting Rock Shaft Crank with 157j and 1813.....
157j	782	Feed Lifting Rock Shaft Crank Clamping Screw.....
43976	5804	Feed Lifting Rock Shaft Crank Connect- ing Rod with 43977 and two 966E....
*43977	—	Feed Lifting Rock Shaft Crank Connect- ing Rod Cap.....
966E	5806	Feed Lifting Rock Shaft Crank Connect- ing Rod Cap Screw.....
375c	782	Feed Lifting Rock Shaft Crank Connect- ing Rod Hinge Screw.....
1518j	783	Feed Lifting Rock Shaft Crank Connect- ing Rod Hinge Screw Nut.....
1813	783	Feed Lifting Rock Shaft Crank Roller and Stud.....
307c	783	Feed Lifting Rock Shaft Crank Screw Centre.....
56814	—	Feed Lifting Rock Shaft Crank Screw Centre 307c with 1513j.....
1513j	783	Feed Lifting Rock Shaft Crank Screw Centre Nut.....
834D	5740	Feed Regulating Thumb Screw.....
12332	5740	" Regulator and Reverser.....
1128E	1366	" " " " Hinge Screw
12333	5740	" " Handle.....
12323	5740	" " " Friction Spring..
835D	5740	" " " Screw.....
12379	766	" Rock Shaft.....
29633	5736	" " " Crank with 157j.....
157j	782	" " " " Clamping Screw
20333	—	Feed Rock Shaft complete, Nos. 12379 and 29633.....
307c	783	Feed Rock Shaft Screw Centre.....
56814	—	" " " " " 307c with 1513j.....
1513j	783	Feed Rock Shaft Screw Centre Nut.....
12381	767	Needle Bar (hollow).....
*12382	770	" " Connecting Link with 794E..
43997	—	" " " " 12382 with 12384.....
794E	782	Needle Bar Connecting Link Adjusting Screw.....
*12383	—	Needle Bar Connecting Stud.....

NO.	PLATE	NAME
1904	770	Needle Bar Connecting Stud Roller (roller only).....
453c	783	Needle Bar Connecting Stud Set Screw.....
12384	770	Needle Bar Connecting Stud complete, Nos. 453c, 1904 and 12383.....
20188	767	Needle Bar Crank with 858c and 1065c.....
1065c	2011	“ “ “ Position Screw.....
858c	783	“ “ “ Set Screw.....
936e	773	“ “ Screw Bushing.....
4302	773	“ “ Thread Guide.....
233D	782	“ “ “ Screw.....
4303	773	“ Clamp with 808F.....
808F	782	“ “ Screw.....
*24104	2001	Oscillating Rock Shaft.....
24105	—	Oscillating Rock Shaft complete, Nos. 4784, 12388 and 24104.....
12388	767	Oscillating Rock Shaft Hinge Pin.....
448c	783	“ “ “ “ “ Set Screw.....
4784	1353	“ “ “ “ “ Oil Pad.....
12389	766	“ Shaft.....
19496	—	“ “ Crank for 19447.....
44134	—	“ “ “ “ 44135.....
2049	773	“ “ “ Pin.....
457c	783	“ “ “ Set Screw for 19447.....
453c	783	“ “ “ “ “ 44135.....
19448	2011	“ “ “ Slide Block.....
226D	1371	“ “ “ “ “ Cap Screw.....
12424	773	Oscillating Shaft Crank Slide Block Cap Screw Washer.....
988c	2011	Oscillating Shaft Crank Slide Block Screw Stud.....
1518J	783	Oscillating Shaft Crank Slide Block Screw Stud Nut.....
19449	2011	Oscillating Shaft Crank Slide Block complete, Nos. 226D, 988c, 12424 and 19448.....
19447	2011	Oscillating Shaft Crank complete, Nos. 457c, 1518J, 19449 and 19496.....
44135	5806	Oscillating Shaft Crank complete, Nos. 1518J, 19449, 44134 and two 453c.....
12391	767	Presser Bar (hollow).....
20059	5736	“ “ Guide Bracket with 453c.....
453c	783	“ “ “ “ Set Screw.....
2062	771	“ “ Lifter.....
689c	782	“ “ “ Screw.....
1520J	783	“ “ “ “ Nut.....

NO.	PLATE	NAME
12327	770	Presser Bar Lifting and Releasing Lever Bracket.....
11167	767	Presser Bar Spring (light) .051 wire.....
NOTE: No. 11167 is sent with this machine, unless another Spring is specified on order		
12139	2004	Presser Bar Spring (medium) .055 wire...
20023	2004	“ “ “ (heavy) .063 wire.....
11170	771	“ “ “ Washer.....
12144	780	“ Foot for 20304.....
NOTE: No. 12144 is sent with this machine, unless another Presser Foot is specified on order		
20328	781	Presser Foot for 20303.....
20038	780	“ “ “ 20303.....
190D	782	“ “ “ Screw.....
688J	783	Pressure Regulating Thumb Screw.....
2996	771	Shuttle Bobbin.....
62739	—	“ “ Case.....
15140	2013	“ “ “ Latch.....
2973	771	“ “ “ “ Lever.....
2974	771	“ “ “ “ “ Fulcrum Pin.....
2975	771	Shuttle Bobbin Case Latch Spring.....
592E	782	“ “ “ “ “ Stop Screw....
15141	—	Shuttle Bobbin Case Hinge, Nos. 2973, 2974 and 15140.....
7553	771	Shuttle Bobbin Case Position Finger.....
2523	771	“ “ “ “ “ Rivet.....
24412	1361	“ “ “ “ “ Plate.....
391D	1366	“ “ “ “ “ Screw.....
62740	771	Shuttle Bobbin Case complete, Nos. 591F, 592F, 2523, 2975, 7553, 15141, 15278 and 62739.....
12393	771	Shuttle Body.....
591F	782	“ Tension Regulating Screw.....
15278	771	“ “ Spring.....
19292	771	Shuttle, 1 $\frac{11}{16}$ in. diam., Nos. 2996, 12393 and 62740.....
*12394	—	Shuttle Driver.....
12444	771	“ “ 12394 with two 1266c.....
2049	773	“ “ Pin.....
1266c	5806	“ “ Set Screw.....
2531	767	“ Race Back.....
2532	772	“ “ “ Position Pin.....
2533	767	“ “ “ Spring.....
907D	782	“ “ “ “ “ Screw.....



NO.	PLATE	NAME
24413	—	Shuttle Race Body.....
25000	—	" " " 24413 with 24414 and two 1053p.....
24414	5837	Shuttle Race Cap.....
1053D	2006	" " " Screw.....
24415	1361	Shuttle Race complete, Nos. 907D, 2531, 2533, 24412, 25000 and two each 391D and 2532.....
145D	782	Shuttle Race Screw.....
12431	—	" " Slide.....
4307	772	" " " Spring.....
725E	1387	" " " " Screw.....
12432	2004	Shuttle Race Slide complete, Nos. 4307, 12431 and two 725E.....
20060	5736	Slack Thread Regulator.....
225F	5736	" " " Adjusting Screw
2102	5806	Tension Disc.....
1560c	783	" Regulating Thumb Nut.....
32572	5806	" Releasing Disc.....
43944	5806	" " Lever.....
12398	773	" " " Hinge Pin.....
12329	772	" " " Spring.....
32574	5806	" " Pin.....
50327c	5806	" Screw Stud.....
44141	—	" " " 50327c with 1560c...
43945	5806	" Spring.....
44118	—	Tension complete, Nos. 7336, 32572, 32574, 43945, 44141, 43946 and two 2102
52454	5842	Thread Retainer.....
624c	8628	" " Set Screw.....
12404	770	" Take-up Crank.....
3094	773	" " " Wedge.....
690E	782	" " " " Screw....
12408	770	" " Lever.....
775E	782	" " " Cap Screw.....
12166	773	" " " Hinge Pin.....
12409	770	" " " Link.....
11204	770	" " " " Hinge Pin...
435c	5806	" " " " " " Set Screw.....
12410	—	Thread Take-up Lever complete, Nos. 12166, 12408 and 12409.....
43946	5806	Thread Take-up Spring.....
7336	772	" " " Regulator.....
448c	783	" " " " Set Screw
*43990	—	Thread Take-up complete, Nos. 775E, 11204, 12404, 12410 and 43997.....

NO.	PLATE	NAME
12414	—	Throat Plate, large needle hole, for 20304
NOTE: Two No. 12414 are sent with this machine, unless other Throat Plates are specified on order		
12442	778	Throat Plate, small needle hole, for 20304
44255	5813	" " " " " " 44254
44256	—	" " large needle hole, for 44254
691F	782	" " Screw.....
44212	5844	Drip Pan with four 1 in. wire nails, for power table.....

SINGER Needles should be used  
in SINGER Machines  
These Needles and their Containers  
are marked with the  
Company's Trade Mark "SIMANCO.\*\*" 1

Needles in Containers marked  
"FOR SINGER MACHINES"  
are NOT SINGER made needles. 2

**LIST OF PARTS COMPLETE  
FOR  
MACHINE No. 31-34**

**FOR HORSE BLANKETS, BURLAP AND OTHER WORK. MAKES  
STITCH UP TO 1/8 INCH LONG. DROP FEED.**

NO.	PLATE	NAME
*12355	—	Arm with 11104.....
8582	773	" Dowel Pin.....
12453	773	" Oil Tube for intermediate bearing...
11119	773	" " " with 52045, for oiling 12408
12454	773	" " " " " " " 12409
24131	2014	" " " " " " " 12428
52045	8628	" " " Packing (braided cotton)...
748E	782	" Screw (back).....
854E	783	" " (front).....
12427	766	" Shaft.....
*44217	—	" " 12427 with 12428, 20188 and 20197.....
*11104	—	Arm Shaft Bushing (front).....
12357	767	" " Flanged Bushing (back).....
448C	783	" " " " " " Set Screw.....
144D	782	Arm Shaft Screw.....
12480	767	" Side Cap.....
219D	774	" " " Screw.....
12193	2004	" " Cover.....
286D	783	" " " Thumb Screw.....
12403	772	" Spool Pin and Thread Eyelet.....
11241	2003	" " " Washer (cloth).....
12358	2000	Balance Wheel (power) light rim, 2 1/8 in. pulley, with two 448c.....
4370	2000	Balance Wheel (stand) heavy rim, 2 3/4 in. pulley, with two 448c.....
2135	2000	Balance Wheel (stand) heavy rim, 2 1/2 in. pulley, for 3022.....
2862	—	Balance Wheel (stand) heavy rim, 3 in. pulley, for 3022.....
448c	783	Balance Wheel Set Screw.....
*12360	—	Bed.....
256J	2003	Clamp Stop Motion Clamp Screw.....
248A	2011	" " " " Stop Screw...
2020	2003	" " " " Washer.....
*3023	—	" " " Flanged Bushing...
4933	2003	" " " " " 3023 with two 462c.....

NO.	PLATE	NAME
2022	773	Clamp Stop Motion Flanged Bushing Pin
462c	773	" " " " " " Set Screw.....
3022J	—	Clamp Stop Motion complete, Nos. 248A, 256J, 2020 and 4933.....
20197	2001	Crank Connecting Rod with 20198 and two 896E.....
*20198	—	Crank Connecting Rod Cap.....
896E	773	" " " " Screw.....
908c	773	" " " " Hinge Screw.....
1619E	773	" " " " " Nut
20057	—	Face Plate.....
*44181	—	" " Thread Guard (lower).....
12150	773	" " " " " 44181 with 12152.....
12152	773	Face Plate Thread Guard (lower) Rivet
2827	773	" " " " (upper) with 8505.....
8505	773	Face Plate Thread Guard (upper) Rivet
20058	5735	Face Plate complete, Nos. 2827, 12150 and 20057.....
190D	782	Face Plate Screw.....
286D	783	" " Thumb Screw.....
44226	8629	Feed Bar.....
313c	783	" " Screw Centre.....
56813	—	" " " " 313c with 1519J
1519J	783	" " " " Nut.....
3033	770	" Connecting Link.....
375c	782	" " " Hinge Screw.....
1518J	783	" " " " " Nut
43923	5743	" Dog, 12 teeth (12 teeth to the inch)
NOTE: No. 43923 is sent with this machine, unless another Feed Dog is specified on order		
20355	1274	Feed Dog, 14 teeth (12 teeth to the inch)
208E	782	" " Screw.....
12428	767	" and Feed Lifting Eccentric with 446c
446c	783	" " " " " Set Screw
43924	5757	" Forked Connection.....
44188	—	" " " " 43924 with 818D 3033, 3039 and two each 375c and 1518J
375c	782	Feed Forked Connection Hinge Screw.....
1518J	783	" " " " " Nut
44125	5804	" Lifting Rock Shaft.....
44126	—	Feed Lifting Rock Shaft complete, Nos. 12376 and 44125.....

NO.	PLATE	NAME
1904	770	Needle Bar Connecting Stud Roller (roller only).....
453c	783	Needle Bar Connecting Stud Set Screw.
12384	770	Needle Bar Connecting Stud complete, Nos. 453c, 1904 and 12383.....
20188	767	Needle Bar Crank with 858c and 1065c..
1065c	2011	" " " Position Screw.....
858c	783	" " " Set Screw.....
936E	773	" " Screw Bushing.....
4302	773	" " Thread Guide.....
233D	782	" " " Screw.....
4303	773	" Clamp with 808F.....
808F	782	" " Screw.....
*24104	2001	Oscillating Rock Shaft.....
24105	—	Oscillating Rock Shaft complete, Nos. 4784, 12388 and 24104.....
12388	767	Oscillating Rock Shaft Hinge Pin.....
448c	783	" " " " " Set Screw
4784	1353	" " " Oil Pad.....
12389	766	" Shaft.....
19496	—	" " Crank for 19447.....
44134	—	" " " " 44135.....
2049	773	" " " Pin.....
457c	783	" " " Set Screw for 19447
453c	783	" " " " " " 44135
19448	2011	" " " Slide Block.....
226D	1371	" " " " " Cap Screw.....
12424	773	Oscillating Shaft Crank Slide Block Cap Screw Washer.....
988c	2011	Oscillating Shaft Crank Slide Block Screw Stud.....
1518j	783	Oscillating Shaft Crank Slide Block Screw Stud Nut.....
19449	2011	Oscillating Shaft Crank Slide Block complete, Nos. 226D, 988c, 12424 and 19448
19447	2011	Oscillating Shaft Crank complete, Nos. 457c, 1518j, 19449 and 19496.....
44135	5806	Oscillating Shaft Crank complete, Nos. 1518j, 19449, 44134 and two 453c.....
12391	767	Presser Bar (hollow).....
20059	5736	" " Guide Bracket with 453c....
453c	783	" " " " Set Screw....
2062	771	" " Lifter.....
689c	782	" " " Screw.....
1520j	783	" " " " Nut.....

NO.	PLATE	NAME
12327	770	Presser Bar Lifting and Releasing Lever Bracket.....
11167	767	Presser Bar Spring (light) .051 wire.....
NOTE: No. 11167 is sent with this machine, unless another Spring is specified on order		
12139	2004	Presser Bar Spring (medium) .055 wire...
20023	2004	" " " (heavy) .063 wire.....
11170	771	" " " Washer.....
12144	780	" Foot for 20304.....
NOTE: No. 12144 is sent with this machine, unless another Presser Foot is specified on order		
20328	781	Presser Foot for 20303.....
20038	780	" " " 20303.....
190D	782	" " Screw.....
688j	783	Pressure Regulating Thumb Screw.....
2996	771	Shuttle Bobbin.....
62739	—	" " Case.....
15140	2013	" " " Latch.....
2973	771	" " " Lever.....
2974	771	" " " " " Fulerum Pin.....
2975	771	Shuttle Bobbin Case Latch Spring.....
592E	782	" " " " Stop Screw...
15141	—	Shuttle Bobbin Case Hinge, Nos. 2973, 2974 and 15140.....
7553	771	Shuttle Bobbin Case Position Finger....
2523	771	" " " " " Rivet
24412	1361	" " " " " Plate.....
391D	1366	" " " " " Screw
62740	771	Shuttle Bobbin Case complete, Nos. 591F, 592F, 2523, 2975, 7553, 15141, 15278 and 62739.....
12393	771	Shuttle Body.....
591F	782	" Tension Regulating Screw.....
15278	771	" Spring.....
19292	771	Shuttle, 1 $\frac{1}{16}$ in. diam., Nos. 2996, 12393 and 62740.....
*12394	—	Shuttle Driver.....
12444	771	" " 12394 with two 1266c....
2049	773	" " Pin.....
1266c	5806	" " Set Screw.....
2531	767	" Race Back.....
2532	772	" " Position Pin.....
2533	767	" " " Spring.....
907D	782	" " " " Screw.....

NO.	PLATE	NAME
24413	—	Shuttle Race Body.....
25000	—	“ “ “ 24413 with 24414 and two 1053p.....
24414	5837	Shuttle Race Cap.....
1053D	2006	“ “ “ Screw.....
24415	1361	Shuttle Race complete, Nos. 907D, 2531, 2533, 24412, 25000 and two each 391D and 2532.....
145D	782	Shuttle Race Screw.....
12431	—	“ “ Slide.....
4307	772	“ “ “ Spring.....
725E	1387	“ “ “ “ Screw.....
12432	2004	Shuttle Race Slide complete, Nos. 4307, 12431 and two 725E.....
20060	5736	Slack Thread Regulator.....
225F	5736	“ “ “ Adjusting Screw.....
2102	5806	Tension Disc.....
1560C	783	“ Regulating Thumb Nut.....
32572	5806	“ Releasing Disc.....
43944	5806	“ “ Lever.....
12398	773	“ “ “ Hinge Pin.....
12329	772	“ “ “ Spring.....
32574	5806	“ “ Pin.....
50327C	5806	“ Screw Stud.....
44141	—	“ “ “ 50327C with 1560C...
43945	5806	“ Spring.....
44118	—	Tension complete, Nos. 7336, 32572, 32574, 43945, 44141, 43946 and two 2102
52454	5842	Thread Retainer.....
624C	8628	“ “ Set Screw.....
12404	770	“ Take-up Crank.....
3094	773	“ “ “ Wedge.....
690E	782	“ “ “ “ Screw....
12408	770	“ “ Lever.....
775E	782	“ “ “ Cap Screw.....
12166	773	“ “ “ Hinge Pin.....
12409	770	“ “ “ Link.....
11204	770	“ “ “ “ Hinge Pin...
435C	5806	“ “ “ “ “ “ Set Screw.....
12410	—	Thread Take-up Lever complete, Nos. 12166, 12408 and 12409.....
43946	5806	Thread Take-up Spring.....
7336	772	“ “ “ Regulator.....
448C	783	“ “ “ “ Set Screw
*43990	—	Thread Take-up complete, Nos. 775E, 11204, 12404, 12410 and 43997.....

NO.	PLATE	NAME
12414	—	Throat Plate, large needle hole, for 20304
NOTE: Two No. 12414 are sent with this machine, unless other Throat Plates are specified on order		
12442	778	Throat Plate, small needle hole, for 20304
44255	5813	“ “ “ “ “ “ 44254
44256	—	“ “ large needle hole, for 44254
691F	782	“ “ Screw.....
44212	5844	Drip Pan with four 1 in. wire nails, for power table.....

SINGER Needles should be used  
in SINGER Machines  
These Needles and their Containers  
are marked with the  
Company's Trade Mark "SIMANCO.\*\*" 1

Needles in Containers marked  
"FOR SINGER MACHINES"  
are NOT SINGER made needles. 2

**LIST OF PARTS COMPLETE  
FOR  
MACHINE No. 31-34**

**FOR HORSE BLANKETS, BURLAP AND OTHER WORK. MAKES  
STITCH UP TO 1/8 INCH LONG. DROP FEED.**

NO.	PLATE	NAME
*12355	—	Arm with 11104.....
8582	773	" Dowel Pin.....
12453	773	" Oil Tube for intermediate bearing...
11119	773	" " " with 52045, for oiling 12408
12454	773	" " " " " " " 12409
24131	2014	" " " " " " " 12428
52045	8628	" " " Packing (braided cotton)...
748E	782	" Screw (back).....
854E	783	" " (front).....
12427	766	" Shaft.....
*44217	—	" " 12427 with 12428, 20188 and 20197.....
*11104	—	Arm Shaft Bushing (front).....
12357	767	" " Flanged Bushing (back).....
448c	783	" " " " " " Set Screw.....
144D	782	Arm Shaft Screw.....
12480	767	" Side Cap.....
219D	774	" " " Screw.....
12193	2004	" " Cover.....
286D	783	" " " Thumb Screw.....
12403	772	" Spool Pin and Thread Eyelet.....
11241	2003	" " " Washer (cloth).....
12358	2000	Balance Wheel (power) light rim, 2 1/8 in. pulley, with two 448c.....
4370	2000	Balance Wheel (stand) heavy rim, 2 3/4 in. pulley, with two 448c.....
2135	2000	Balance Wheel (stand) heavy rim, 2 1/2 in. pulley, for 3022.....
2862	—	Balance Wheel (stand) heavy rim, 3 in. pulley, for 3022.....
448c	783	Balance Wheel Set Screw.....
*12360	—	Bed.....
256J	2003	Clamp Stop Motion Clamp Screw.....
248A	2011	" " " " Stop Screw...
2020	2003	" " " " Washer.....
*3023	—	" " " Flanged Bushing....
4933	2003	" " " " " 3023 with two 462c.....

NO.	PLATE	NAME
2022	773	Clamp Stop Motion Flanged Bushing Pin
462c	773	" " " " " " Set Screw.....
3022J	—	Clamp Stop Motion complete, Nos. 248A, 256J, 2020 and 4933.....
20197	2001	Crank Connecting Rod with 20198 and two 896E.....
*20198	—	Crank Connecting Rod Cap.....
896E	773	" " " " Screw.....
908c	773	" " " " Hinge Screw....
1619E	773	" " " " " Nut
20057	—	Face Plate.....
*44181	—	" " Thread Guard (lower).....
12150	773	" " " " " 44181 with 12152.....
12152	773	Face Plate Thread Guard (lower) Rivet
2827	773	" " " " (upper) with 8505.....
8505	773	Face Plate Thread Guard (upper) Rivet
20058	5735	Face Plate complete, Nos. 2827, 12150 and 20057.....
190D	782	Face Plate Screw.....
286D	783	" " Thumb Screw.....
44226	8629	Feed Bar.....
313c	783	" " Screw Centre.....
56813	—	" " " " 313c with 1519J
1519J	783	" " " " Nut.....
3033	770	" Connecting Link.....
375c	782	" " " Hinge Screw....
1518J	783	" " " " " Nut
43923	5743	" Dog, 12 teeth (12 teeth to the inch)

NOTE: No. 43923 is sent with this machine, unless  
another Feed Dog is specified on order

20355	1274	Feed Dog, 14 teeth (12 teeth to the inch)
208E	782	" " Screw.....
12428	767	" and Feed Lifting Eccentric with 446c
446c	783	" " " " " Set Screw
43924	5757	" Forked Connection.....
44188	—	" " " 43924 with 818D 3033, 3039 and two each 375c and 1518J
375c	782	Feed Forked Connection Hinge Screw....
1518J	783	" " " " " Nut
44125	5804	" Lifting Rock Shaft.....
44126	—	Feed Lifting Rock Shaft complete, Nos. 12376 and 44125.....

NO.	PLATE	NAME
12376	770	Feed Lifting Rock Shaft Crank with 157J and 1813.....
157J	782	Feed Lifting Rock Shaft Crank Clamping Screw.....
43976	5804	Feed Lifting Rock Shaft Crank Connecting Rod with 43977 and two 966E.....
*43977	—	Feed Lifting Rock Shaft Crank Connecting Rod Cap.....
966E	5806	Feed Lifting Rock Shaft Crank Connecting Rod Cap Screw.....
375c	782	Feed Lifting Rock Shaft Crank Connecting Rod Hinge Screw.....
1518J	783	Feed Lifting Rock Shaft Crank Connecting Rod Hinge Screw Nut.....
1813	783	Feed Lifting Rock Shaft Crank Roller and Stud.....
307c	783	Feed Lifting Rock Shaft Screw Centre.....
56814	—	“ “ “ “ “ “ 307c with 1513J.....
1513J	783	Feed Lifting Rock Shaft Screw Centre Nut.....
3039	768	“ Regulator.....
1128E	2009	“ “ Hinge Screw.....
818D	783	“ “ Thumb Screw.....
12379	766	“ Rock Shaft.....
29633	5736	“ “ “ Crank with 157J.....
157J	782	“ “ “ “ Clamping Screw.....
20333	—	Feed Rock Shaft complete, Nos. 12379 and 29633.....
307c	783	Feed Rock Shaft Screw Centre.....
56814	—	“ “ “ “ “ “ 307c with 1513J.....
1513J	783	Feed Rock Shaft Screw Centre Nut.....
12381	767	Needle Bar (hollow).....
*12382	770	“ “ Connecting Link with 794E.....
43997	—	“ “ “ “ 12382 with 12384.....
794E	782	Needle Bar Connecting Link Adjusting Screw.....
*12383	—	Needle Bar Connecting Stud.....
1904	770	“ “ “ “ Roller (roller only).....
453c	783	Needle Bar Connecting Stud Set Screw.....
12384	770	Needle Bar Connecting Stud complete, Nos. 453c, 1904 and 12383.....
20188	767	Needle Bar Crank with 858c and 1065c.....
1065c	2011	“ “ “ Position Screw.....
858c	783	“ “ “ Set Screw.....

NO.	PLATE	NAME
936E	773	Needle Bar Screw Bushing.....
4302	773	“ “ Thread Guide.....
233D	782	“ “ “ “ Screw.....
4303	773	“ Clamp with 808F.....
808F	782	“ “ Screw.....
*24104	2001	Oscillating Rock Shaft.....
24105	—	Oscillating Rock Shaft complete, Nos. 4784, 12388 and 24104.....
12388	767	Oscillating Rock Shaft Hinge Pin.....
448c	783	“ “ “ “ “ Set Screw.....
4784	1353	“ “ “ Oil Pad.....
12389	766	“ Shaft.....
19496	—	“ “ Crank for 19447.....
44134	—	“ “ “ “ 44135.....
2049	773	“ “ “ Pin.....
457c	783	“ “ “ Set Screw for 19447.....
453c	783	“ “ “ “ “ 44135.....
19448	2011	“ “ “ Slide Block.....
226D	1371	“ “ “ “ “ Cap Screw.....
12424	773	Oscillating Shaft Crank Slide Block Cap Screw Washer.....
988c	2011	Oscillating Shaft Crank Slide Block Screw Stud.....
1518J	783	Oscillating Shaft Crank Slide Block Screw Stud Nut.....
19449	2011	Oscillating Shaft Crank Slide Block complete, Nos. 226D, 988c, 12424 and 19448.....
19447	2011	Oscillating Shaft Crank complete, Nos. 457c, 1518J, 19449 and 19496.....
44135	5806	Oscillating Shaft Crank complete, Nos. 1518J, 19449, 44134 and two 453c.....
12391	767	Presser Bar (hollow).....
20059	5736	“ “ Guide Bracket with 453c.....
453c	783	“ “ “ “ Set Screw.....
2062	771	“ “ Lifter.....
689c	782	“ “ “ Screw.....
1520J	783	“ “ “ “ Nut.....
12327	770	“ “ Lifting and Releasing Lever Bracket.....
11167	767	Presser Bar Spring (light) .051 wire.....
NOTE: No. 11167 is sent with this machine, unless another Spring is specified on order		
12139	2004	Presser Bar Spring (medium) .055 wire.....
20023	2004	“ “ “ (heavy) .063 wire.....
11170	771	“ “ “ Washer.....

NO.	PLATE	NAME
43925	780	Presser Foot for 43923.....
NOTE: No. 43925 is sent with this machine, unless another Presser Foot is specified on order		
26276	2038	Presser Foot Hinge Pin.....
20358	—	“ “ Plate.....
19335	—	“ “ Shank.....
20359	781	Presser Foot (hinged) complete, for $\frac{1}{8}$ in. gauge and above, for 20355, Nos. 19335, 20358 and 26276.....
NOTE: When ordering No. 20359, give width of turned edge from seam		
7298	2014	Presser Foot Hinge Pin.....
19334	—	“ “ Plate.....
19335	—	“ “ Shank.....
19336	1308	Presser Foot (hinged) complete for 20355, Nos. 7298, 19334 and 19335.....
190D	782	Presser Foot Screw.....
688J	783	Pressure Regulating Thumb Screw.....
2996	771	Shuttle Bobbin.....
62739	—	“ “ Case.....
15140	2013	“ “ “ Latch.....
2973	771	“ “ “ “ Lever.....
2974	771	“ “ “ “ Fulcrum Pin.....
2975	771	Shuttle Bobbin Case Latch Spring.....
592E	782	“ “ “ “ Stop Screw.....
15141	—	Shuttle Bobbin Case Hinge, Nos. 2973, 2974 and 15140.....
7553	771	Shuttle Bobbin Case Position Finger.....
2523	771	“ “ “ “ Rivet.....
24412	1361	“ “ “ “ Plate.....
391D	1366	“ “ “ “ Screw.....
62740	771	Shuttle Bobbin Case complete, Nos. 591F, 592E, 2523, 2975, 7553, 15141, 15278 and 62739.....
12393	771	Shuttle Body.....
591F	782	“ Tension Regulating Screw.....
15278	771	“ “ Spring.....
19292	771	Shuttle, $1\frac{1}{8}$ in. diam., Nos. 2996, 12393 and 62740.....
*12394	—	Shuttle Driver.....
12444	771	“ “ 12394 with two 1266c.....
2049	773	“ “ Pin.....
1266c	5806	“ “ Set Screw.....
2531	767	“ Race Back.....

NO.	PLATE	NAME
2532	772	Shuttle Race Back Position Pin.....
2533	767	“ “ “ Spring.....
907D	782	“ “ “ “ Screw.....
24413	—	“ “ Body.....
25000	—	“ “ “ 24413 with 24414 and two 1053D.....
24414	5837	Shuttle Race Cap.....
1053D	2006	“ “ “ Screw.....
24415	1361	Shuttle Race complete, Nos. 907D, 2531, 2533, 24412, 25000 and two each 391D and 2532.....
145D	782	Shuttle Race Screw.....
12431	—	“ “ Slide.....
4307	772	“ “ “ Spring.....
725E	1387	“ “ “ “ Screw.....
12432	2004	Shuttle Race Slide complete, Nos. 4307, 12431 and two 725E.....
20060	5736	Slack Thread Regulator.....
225F	5736	“ “ “ Adjusting Screw.....
2102	5806	Tension Disc.....
1560c	783	“ Regulating Thumb Nut.....
32572	5806	“ Releasing Disc.....
43944	5806	“ “ Lever.....
12398	773	“ “ “ Hinge Pin.....
12329	772	“ “ “ Spring.....
32574	5806	“ “ Pin.....
50327c	5806	“ Screw Stud.....
44141	—	“ “ “ 50327c with 1560c.....
43945	5806	“ Spring.....
44118	—	Tension complete, Nos. 7336, 32572, 32574, 43945, 43946, 44141 and two 2102
52454	5842	Thread Retainer.....
624c	8628	“ “ Set Screw.....
12404	770	“ Take-up Crank.....
3094	773	“ “ “ Wedge.....
690E	782	“ “ “ “ Screw.....
12408	770	“ “ Lever.....
775E	782	“ “ “ Cap Screw.....
12166	773	“ “ “ Hinge Pin.....
12409	770	“ “ “ Link.....
11204	770	“ “ “ “ Hinge Pin.....
435c	5806	“ “ “ “ “ “ Set Screw.....
12410	—	Thread Take-up Lever complete, Nos. 12166, 12408 and 12409.....
43946	5806	Thread Take-up Spring.....
7336	772	“ “ “ Regulator.....

NO.	PLATE	NAME
448c	783	Thread Take-up Spring Regulator Set Screw
*43990	—	Thread Take-up complete, Nos. 775E, 11204, 12404, 12410 and 43997.....
43926	5743	Throat Plate for 43923.....

NOTE: Two No. 43926 are sent with this machine, unless other Throat Plates are specified on order

20356	1274	Throat Plate, large needle hole, for 20355
20357	—	“ “ small needle hole, for 20355
691F	782	“ “ Screw.....
44212	5844	Drip Pan with four 1 in. wire nails, for power table.....

**SINGER** Needles should be used  
in **SINGER** Machines  
These Needles and their Containers  
are marked with the  
Company's Trade Mark "**SIMANCO**."\*\* 1

Needles in Containers marked  
"**FOR SINGER MACHINES**"  
are **NOT SINGER** made needles. 2

## LIST OF PARTS COMPLETE FOR MACHINE No. 31-35

**FOR LIGHT OR HEAVY CLOTH, HAS VERTICAL TRIMMER THAT TRIMS FROM  $\frac{1}{8}$  TO  $\frac{1}{4}$  INCH FROM THE SEAM, DROP FEED. BOBBIN NO. 2996. MACHINES ARE FITTED WITH  $\frac{1}{8}$  INCH CUTTING BAR UNLESS OTHERWISE ORDERED, AND AN EXTRA  $\frac{1}{8}$  INCH CUTTING BAR AND PRESSER FOOT ARE ALSO FURNISHED. WHEN A DIFFERENT WIDTH IS ORDERED THE EXTRA CUTTING BAR WILL BE ONE SIZE LARGER EXCEPT WHEN  $\frac{1}{4}$  INCH IS REQUIRED.**

NO.	PLATE	NAME
*43927	—	Arm with 11104.....
8582	773	“ Dowel Pin.....
12453	773	“ Oil Tube for intermediate bearing..
12454	773	“ “ “ with 52045, for oiling 12409
11119	773	“ “ “ “ “ “ “ 12408 and 16569.....
24131	2014	Arm Oil Tube with 52045 for oiling 20283
52045	8628	“ “ “ Packing (braided cotton)..
748E	782	“ Screw (back).....
854E	783	“ “ (front).....
12427	766	“ Shaft.....
*44123	—	“ “ 12427 with 16569, 20283 and 24036.....
*44196	—	Arm Shaft 44123 with 20197.....
*11104	—	“ “ Bushing (front).....
12357	767	“ “ Flanged Bushing (back).....
448c	783	“ “ “ “ “ “ Set Screw.....
144D	782	Arm Shaft Screw.....
12193	2004	“ Side Cover.....
286D	783	“ “ “ Thumb Screw.....
12403	772	“ Spool Pin and Thread Eyelet.....
11241	2003	“ “ “ Washer (cloth).....
12358	2000	Balance Wheel (power) light rim, $2\frac{3}{8}$ in. pulley with two 448c.....
4370	2000	Balance Wheel (stand) heavy rim, $2\frac{3}{4}$ in. pulley with two 448c.....
2135	2000	Balance Wheel (stand) heavy rim, $2\frac{1}{2}$ in. pulley, for 3022.....
2862	—	Balance Wheel (stand) heavy rim, 3 in. pulley, for 3022.....



NO.	PLATE	NAME
448C	783	Balance Wheel Set Screw.....
*12360	—	Bed.....
256J	2003	Clamp Stop Motion Clamp Screw.....
248A	2011	“ “ “ “ Stop Screw...
2020	2003	“ “ “ “ Washer.....
*3023	—	“ “ “ “ Flanged Bushing....
4933	2003	“ “ “ “ “ 3023 with two 462c.....
2022	773	Clamp Stop Motion Flanged Bushing Pin
462c	773	“ “ “ “ “ Set Screw.....
3022J	—	Clamp Stop Motion complete, Nos. 248A, 256J, 2020 and 4933.....
20197	2001	Crank Connecting Rod with 20198 and two 896E.....
*20198	—	Crank Connecting Rod Cap.....
896E	773	“ “ “ “ Screw.....
908c	773	“ “ “ “ Hinge Screw....
1619E	773	“ “ “ “ “ Nut.
16558	—	Face Plate.....
62682	8628	“ “ Thread Eyelet.....
44181	—	“ “ “ “ Guard (lower).....
12150	773	“ “ “ “ “ 44181 with 12152.....
12152	773	Face Plate Thread Guard (lower) Rivet .
2827	773	“ “ “ “ (upper) with 8505.....
8505	773	Face Plate Thread Guard (upper) Rivet
16559	5735	Face Plate complete, Nos. 2827, 12150 and 16558.....
217D	1312	Face Plate Screw.....
12368	767	Feed Bar.....
313c	783	“ “ Screw Centre.....
56813	—	“ “ “ “ 313c with 1519J.
1519J	783	“ “ “ “ Nut.....
3033	770	“ Connecting Link.....
375c	782	“ “ “ “ Hinge Screw.....
1518J	783	“ “ “ “ “ Nut
19103	1271	“ Dog, 12 teeth (16 teeth to the inch)

NOTE: No. 19103 is sent with this machine unless another Feed Dog is specified on order.

24573	1271	Feed Dog, 24 teeth (32 teeth to the inch).
208E	782	“ “ Screw.....
20283	2020	“ and Feed Lifting Eccentric with 446c.....

NO.	PLATE	NAME
446c	783	Feed and Feed Lifting Eccentric Set Screw.....
24036	2020	Feed and Feed Lifting Eccentric Sleeve
20284	2020	Feed Forked Connection.....
375c	782	“ “ “ “ Hinge Screw...
1518J	783	“ “ “ “ “ Nut
*43993	—	Feed Forked Connection complete, Nos. 818D, 3033, 3039, 20284 and two each 375c and 1518J.....
44125	5804	Feed Lifting Rock Shaft.....
44126	—	Feed Lifting Rock Shaft complete, Nos. 12376 and 44125.....
12376	770	Feed Lifting Rock Shaft Crank with 157J and 1813.....
157J	782	Feed Lifting Rock Shaft Crank Clamping Screw.....
43976	5804	Feed Lifting Rock Shaft Crank Connect- ing Rod with 43977 and two 966E.....
*43977	—	Feed Lifting Rock Shaft Crank Connect- ing Rod Cap.....
966E	5806	Feed Lifting Rock Shaft Crank Connect- ing Rod Cap Screw.....
375c	782	Feed Lifting Rock Shaft Crank Connect- ing Rod Hinge Screw.....
1518J	783	Feed Lifting Rock Shaft Crank Connect- ing Rod Hinge Screw Nut.....
1813	783	Feed Lifting Rock Shaft Crank Roller and Stud.....
307c	783	Feed Lifting Rock Shaft Screw Centre... 56814 — “ “ “ “ “ “ 307c with 1513J.....
1513J	783	Feed Lifting Rock Shaft Screw Centre Nut.....
3039	768	Feed Regulator.....
1128E	2009	“ “ Hinge Screw.....
818D	783	“ “ “ “ Thumb Screw.....
12379	766	“ Rock Shaft.....
29633	5736	“ “ “ “ Crank with 157J.....
157J	782	“ “ “ “ Clamping Screw
20333	—	Feed Rock Shaft complete, Nos. 12379 and 29633.....
307c	783	Feed Rock Shaft Screw Centre.....
56814	—	“ “ “ “ “ “ 307c with 1513J.....
1513J	783	Feed Rock Shaft Screw Centre Nut.....
5726	1271	Knife.....

NOTE: Two No. 5726 are sent with this machine.

NO.	PLATE	NAME
620F	782	Knife Adjusting Screw.....
19297	5738	" Bar with 2301.....
24431	5841	" " Crank with 191c.....
1162c	1366	" " " Coupling Pin.....
1564D	2038	" " " " Head.....
2297	2038	" " " " Spring.....
2022	773	" " " Pin.....
191c	1366	" " " Set Screw.....
24432	—	Knife Bar Crank complete, Nos. 1162, 1564D 2297 and 24431.....
16563	5738	Knife Bar Driving Crank (forked).....
16564	5738	" " " Bracket.....
24433	—	Knife Bar Driving Crank Bracket com- plete, Nos. 2022, 16563, 16564 and 24432
647c	774	Knife Bar Driving Crank Bracket Screw
24122	1317	" " Lifting Spring.....
24123	1317	" " " Case.....
24124	1317	" " " " Guide.....
*24906	—	" " " " " 24124 with 2523 and 24125.....
24125	1317	Knife Bar Lifting Spring Guide Bracket
621D	1317	" " " " " " "
		Screw.....
2523	1317	Knife Bar Lifting Spring Guide Pin.....
2301	1317	" " Stop Pin.....
24128	—	Knife Bar complete, Nos. 621D, 19297, 19391, 24109, 24906 and three 335H....
19391	1321	Knife Holder with 620F, 2291 and two 223F.....
24109	1321	Knife Holder Handle.....
335H	1317	" " " Screw.....
335H	1317	" " " Screw.....
223F	1317	" " " Screw.....
2291	1317	" " Washer.....
16568	5841	Needle Bar with 620F, 904F and 24391...
*12382	770	" " Connecting Link with 794E...
43997	—	" " " " 12382 with 12384.....
794E	782	Needle Bar Connecting Link Adjusting Screw.....
*12383	—	Needle Bar Connecting Stud.....
1904	770	" " " " Roller (roller only.....
453c	783	Needle Bar Connecting Stud Set Screw.
12384	770	Needle Bar Connecting Stud complete, Nos. 453c, 1904 and 12383.....

NO.	PLATE	NAME
16569	5738	Needle Bar Crank (eccentric) with 448c and 743c.....
743c	1317	Needle Bar Crank Position Screw.....
448c	783	" " " Set Screw.....
24391	1321	" " Thread Guide.....
620F	782	" " " " Set Screw.....
904F	8628	" " Set Screw.....
*24104	2001	Oscillating Rock Shaft.....
24105	—	Oscillating Rock Shaft complete, Nos. 4784, 12388 and 24104.....
12388	767	Oscillating Rock Shaft Hinge Pin.....
448c	783	" " " " " Set Screw
4784	1353	" " " " Oil Pad.....
12389	766	" Shaft.....
19496	—	" " Crank for 19447.....
44134	—	" " " " 44135.....
2049	773	" " " Pin.....
457c	783	" " " Set Screw for 19447
453c	783	" " " " " 44135
19448	2011	" " " Slide Block.....
226D	1371	" " " " " Cap Screw.....
12424	773	Oscillating Shaft Crank Slide Block Cap Screw Washer.....
988c	2011	Oscillating Shaft Crank Slide Block Screw Stud.....
1518J	783	Oscillating Shaft Crank Slide Block Screw Stud Nut.....
19449	2011	Oscillating Shaft Crank Slide Block com- plete, Nos. 226D, 988c, 12424 and 19448
19447	2011	Oscillating Shaft Crank complete, Nos. 457c, 1518J, 19449 and 19496.....
44135	5806	Oscillating Shaft Crank complete, Nos. 1518J, 19449, 44134 and two 453c.....
12391	767	Presser Bar (hollow).....
12326	770	" " Guide Bracket with 453c....
453c	783	" " " " Set Screw.....
2062	771	" " Lifter.....
689c	782	" " " Screw.....
1520J	783	" " " " Nut.....
12327	770	" " Lifting and Releasing Lever Bracket.....
11167	767	Presser Bar Spring (light) .051 wire.....

NOTE: No. 11167 is sent with this machine  
unless another Spring is specified on order

NO.	PLATE	NAME
12139	2004	Presser Bar Spring (medium) .055 wire...
20023	2004	" " " (heavy) .063 wire....
11170	771	" " " Washer.....
24722	1271	Foot, for $\frac{1}{16}$ in. to $\frac{3}{16}$ in. gauge....
19392	1271	" " " $\frac{3}{16}$ in. gauge and above.

NOTE: No. 24722,  $\frac{1}{8}$  in. gauge, and No. 19392,  $\frac{3}{16}$  in. gauge, are sent with this machine unless other Gauges are specified on order

190D	782	Presser Foot Screw.....
688J	783	Pressure Regulating Thumb Screw.....
2996	771	Shuttle Bobbin.....
62739	—	" " Case.....
15140	2013	" " " Latch.....
2973	771	" " " " Lever.....
2974	771	" " " " " Fulcrum Pin.....
2975	771	Shuttle Bobbin Case Latch Spring.....
592B	782	" " " " Stop Screw..
15141	—	Shuttle Bobbin Case Hinge, Nos. 2973, 2974 and 15140.....
7553	771	Shuttle Bobbin Case Position Finger.....
2523	771	" " " " " Rivet
24412	1361	" " " " " Plate.....
391D	1366	" " " " " Screw
62740	771	Shuttle Bobbin Case complete, Nos. 591F, 592B, 2523, 2975, 7553, 15141, 15278 and 62739.....
<i>Hook</i> 12393	771	Shuttle Body.....
591F	782	" Tension Regulating Screw.....
15278	771	" " Spring.....
19292	771	Shuttle, $1\frac{1}{8}$ in. diam., Nos. 2996, 12393 and 62740.....
*12394	—	Shuttle Driver.....
12444	771	" " 12394 with two 1266c....
2049,	773	" " Pin.....
1266c	5806	" " Set Screw.....
2531	767	" Race Back.....
2532	772	" " " Position Pin.....
2533	767	" " " Spring.....
907D	782	" " " " Screw.....
24413	—	" " Body.....
62502	—	" " " 24413 with 24418 and two 1053D.....
24418	8628	Shuttle Race Cap.....
1053D	2006	" " " Screw.....

NO.	PLATE	NAME
24419	—	Shuttle Race complete, Nos. 907D, 2531, 2533, 24412, 62502, and two each 391D and 2532.....
145D	782	Shuttle Race Screw.....
12431	—	" " Slide.....
4307	772	" " " Spring.....
725E	1387	" " " " Screw.....
12432	2004	Shuttle Race Slide complete, Nos. 4307, 12431 and two 725E.....
2102	5806	Tension Disc.....
1560c	783	" Regulating Thumb Nut.....
32572	5806	" Releasing Disc.....
43944	5806	" " Lever.....
12398	773	" " " Hinge Pin.....
12329	772	" " " Spring.....
32574	5806	" " Pin.....
50327c	5806	" Screw Stud.....
44141	—	" " " 50327c with 1560c..
43945	5806	" Spring.....
12149	2014	" Thread Guard.....
44118	—	Tension complete, Nos. 7336, 32572, 32574, 43945, 43946, 44141 and two 2102.....
52454	5842	Thread Retainer.....
624c	8628	" " Set Screw.....
12404	770	" Take-up Crank.....
3094	773	" " " Wedge.....
690E	782	" " " " Screw....
12408	770	" " Lever.....
775E	782	" " " Cap Screw.....
12166	773	" " " Hinge Pin.....
12409	770	" " " Link.....
11204	770	" " " " Hinge Pin ...
435c	5806	" " " " " " Set Screw.....
12410	—	Thread Take-up Lever complete, Nos. 12166, 12408 and 12409.....
43946	5806	Thread Take-up Spring.....
7336	772	" " " Regulator.....
448c	783	" " " " SetScrew
*43990	—	Thread Take-up complete, Nos. 775E, 11204, 12404, 12410 and 43997.....
5729	—	Throat Plate Body.....

NO.	PLATE	NAME
5730	1271	Throat Plate Cutting Bar.....

NOTE: When ordering No. 5730 state required distance of trimmed edge from seam.

NOTE: 5730,  $\frac{3}{16}$  in. gauge, is sent with this machine unless another Gauge is specified on order.

578D	5837	Throat Plate Cutting Bar Screw.....
5731	1271	" " Slide.....
578D	5837	" " " Adjusting Screw.....
5732	1271	Throat Plate complete for 19103 and 24573, Nos. 5729 to 5731 and three 578D.....

NOTE: When ordering No. 5732 state required distance from trimmed edge to seam.

NOTE: No. 5732,  $\frac{1}{2}$  in. gauge, is sent with this machine unless another Gauge is specified on order.

691F	782	Throat Plate Screw.....
44212	5844	Drip Pan with four 1 in. wire nails, for power table.....

**SINGER** Needles should be used  
in **SINGER** Machines  
These Needles and their Containers  
are marked with the  
Company's Trade Mark "SIMANCO.\*\*" 1

Needles in Containers marked  
"FOR SINGER MACHINES"  
are NOT **SINGER** made needles. 2

## LIST OF PARTS COMPLETE FOR MACHINE No. 31-37

**MAKES SINGLE, DOUBLE OR TRIPLE BOX PLAITS OR RUFFLES  
ACROSS STRIPS UP TO  $2\frac{1}{4}$  INCHES WIDE, OR UPON THE  
EDGES OF WIDE FABRICS, AND STITCHES THEM DOWN  
FROM  $\frac{1}{8}$  TO  $1\frac{1}{2}$  INCHES FROM THE EDGES, AT THE SAME  
TIME STITCHING THEM TO ANOTHER PIECE IF DESIRED.**

NO.	PLATE	NAME
*20490	—	Arm with 11104.....
8582	773	" Dowel Pin.....
12453	773	" Oil Tube for intermediate bearing..
11119	773	" " " with 52045, for oiling 12408
12454	773	" " " " " " " 12409
24131	2014	" " " " " " " 20283
52045	8628	" " Packing (braided cotton)..
748E	782	" Screw (back).....
854E	783	" " (front).....
20400	5735	" Shaft.....
*44169	—	" " 20400 with 20188, 20283, 20426 and 24036.....
*44199	—	Arm Shaft 44169 with 20197.....
*11104	—	" " Bushing (front).....
12357	767	" " Flanged Bushing (back).....
448C	783	" " " " " " Set Screw.....
144D	782	Arm Shaft Screw.....
12480	767	" Side Cap.....
219D	774	" " " Screw.....
12193	2004	" " Cover.....
286D	783	" " " Thumb Screw.....
12403	772	" Spool Pin and Thread Eyelet.....
11241	2003	" " " Washer (cloth).....
4370	2000	Balance Wheel (stand) heavy rim, $2\frac{3}{4}$ in. pulley, with two 448c.....
448C	783	Balance Wheel Set Screw.....
*20401	—	Bed.....
20197	2001	Crank Connecting Rod with 20198 and two 896E.....
*20198	—	Crank Connecting Rod Cap.....
896E	773	" " " " " Screw.....
908C	773	" " " " " Hinge Screw.....
1619E	773	" " " " " Nut.....

NO.	PLATE	NAME
43890	5755	Edge Guide.....
212D	5755	" " Screw.....
20057	—	Face Plate.....
*44181	—	" " Thread Guard (lower).....
12150	773	" " " " " 4 4 1 8 1 with 12152.....
12152	773	Face Plate Thread (lower) Rivet.....
2827	773	" " " Guard (upper) with 8505.....
8505	773	Face Plate Thread Guard (upper) Rivet
20058	5735	Face Plate complete, Nos. 2827, 12150, and 20057.....
190D	782	Face Plate Screw.....
286D	783	" " Thumb Screw.....
12368	767	Feed Bar.....
313C	783	" " Screw Centre.....
56813	—	" " " " 313C with 1519J..
1519J	783	" " " " Nut.....
3033	770	" Connecting Link.....
375C	782	" " " Hinge Screw.....
1518J	783	" " " " " Nut.
20403	5744	" Dog, 11 teeth (22 teeth to the inch)
208E	782	" " Screw.....
20283	2020	" and Feed Lifting Eccentric with 446C.....
446C	783	Feed and Feed Lifting Eccentric Set Screw
24036	2020	" " " " Sleeve....
20284	2020	" Forked Connection.....
375C	782	" " " Hinge Screw....
1518J	783	" " " " " Nut
*43993	—	Feed Forked Connection complete, Nos. 818D, 3033, 3039, 20284 and two each 375C and 1518J.....
12376	770	Feed Lifting Rock Shaft Crank with 157J and 1813.....
157J	782	Feed Lifting Rock Shaft Crank Clamping Screw.....
44125	5804	Feed Lifting Rock Shaft.....
44126	—	Feed Lifting Rock Shaft complete, Nos. 12376 and 44125.....
43976	5804	Feed Lifting Rock Shaft Crank Connect- ing Rod with 43977 and two 966E.....
*43977	—	Feed Lifting Rock Shaft Crank Connect- ing Rod Cap.....
966E	5806	Feed Lifting Rock Shaft Crank Connect- ing Rod Cap Screw.....

NO.	PLATE	NAME
375C	782	Feed Lifting Rock Shaft Crank Connect- ing Rod Hinge Screw.....
1518J	783	Feed Lifting Rock Shaft Crank Connect- ing Rod Hinge Screw Nut.....
1813	783	Feed Lifting Rock Shaft Crank Roller and Stud.....
307C	783	Feed Lifting Rock Shaft Screw Centre... 56814 — " " " " " 307C
1513J	783	Feed Lifting Rock Shaft Screw Centre Nut with 1513J.....
3039	768	Feed Regulator.....
1128E	2009	" " Hinge Screw.....
818D	783	" " Thumb Screw.....
12379	766	" Rock Shaft.....
29633	5736	" " " Crank with 157J.....
157J	782	" " " " Clamping Screw
20333	—	Feed Rock Shaft complete, Nos. 12379 and 29633.....
307C	783	Feed Rock Shaft Screw Centre..... 56814 — " " " " " 307C with 1513J.....
1513J	783	Feed Rock Shaft Screw Centre Nut.....
12381	767	Needle Bar (hollow).....
*12382	770	" " Connecting Link with 794E..
43997	—	" " " " 12382 with 12384.....
794E	782	Needle Bar Connecting Link Adjusting Screw.....
*12383	—	Needle Bar Connecting Stud.....
1904	770	" " " " Roller (roller only).....
453C	783	Needle Bar Connecting Stud Set Screw..
12384	770	Needle Bar Connecting Stud complete, Nos. 453C, 1904 and 12383.....
20188	767	Needle Bar Crank with 858C and 1065C..
1065C	2011	" " " Position Screw.....
858C	783	" " " Set Screw.....
936E	773	" " Screw Bushing.....
4302	773	" " Thread Guide.....
233D	782	" " " " Screw.....
4303	773	" Clamp with 808F.....
808F	782	" " Screw.....
*24104	2001	Oscillating Rock Shaft.....
24105	—	Oscillating Rock Shaft complete, Nos. 4784, 12388 and 24104.....
12388	767	Oscillating Rock Shaft Hinge Pin.....
448C	783	" " " " " Set Screw

NO.	PLATE	NAME
4784	1353	Oscillating Rock Shaft Oil Pad.....
12389	766	" Shaft.....
19496	—	" " Crank for 19447.....
44134	—	" " " " 44135.....
2049	773	" " " Pin.....
457c	783	" " " Set Screw for 19447
453c	783	" " " " " " 44135
19448	2011	" " " Slide Block.....
226d	1371	" " " " " Cap Screw.....
12424	773	Oscillating Shaft Crank Slide Block Cap Screw Washer.....
988c	2011	Oscillating Shaft Crank Slide Block Screw Stud.....
1518r	783	Oscillating Shaft Crank Slide Block Screw Stud Nut.....
19449	2011	Oscillating Shaft Crank Slide Block com- plete, Nos. 226d, 988c, 12424 and 19448
19447	2011	Oscillating Shaft Crank complete, Nos. 457c, 1518r, 19449 and 19496.....
44135	5806	Oscillating Shaft Crank complete, Nos. 1518r, 19449, 44134 and two 453c.....
20404	5745	Plaiting Blade (lower).....
208d	5745	" " " Screw.....
20405	5746	" " (upper).....
228d	5746	" " " Screw (left).....
208d	5745	" " " " (right).....
20406	5745	" " Holder (lower).....
212f	5745	" " " Cap Screw
43887	5745	" " " " Hinge Stud
1668c	5745	" " " " " "
		Nut.....
8905	5745	Plaiting Blade Holder (lower) Hinge Stud Nut Washer.....
20408	5745	Plaiting Blade Holder (lower) Spring....
43888	5745	" " " " " Stop
50035E	5745	" " " " " "
		Screw.....
1550H	5745	Plaiting Blade Holder (lower) Spring Stop Screw Nut.....
20410	5746	Plaiting Blade Holder (upper).....
212f	5745	" " " " Cap Screw.
43887	5745	" " " " Hinge Stud
1668c	5745	" " " " " "
		Nut.....
8905	5745	Plaiting Blade Holder (upper) Hinge Stud Nut Washer.....

NO.	PLATE	NAME
20411	5746	Plaiting Blade Holder (upper) Spring....
43888	5745	" " " " " Stop
50035E	5745	" " " " " "
		Screw.....
1550H	5745	Plaiting Blade Holder (upper) Spring Stop Screw Nut.....
20412	5745	Plaiting Blade Separating Spring.....
20413	5747	" Cam No. 1.....
20414	5747	" " " 2.....
20415	5747	" " " 3.....
20416	5747	" " " 4.....
20417	5748	" " " 5.....
20418	5748	" " " 6.....
20419	5748	" " " 7.....
20420	5748	" " " 8.....
20421	5749	" " " 9.....
43830	5784	" " " 10.....
43831	5784	" " " 11.....
8386	5746	" " Position Pin.....
20422	5750	" " Shaft with 8386.....
20423	5751	" " " Bracket with 155c and 449c.....
141D	5750	Plaiting Cam Shaft Bracket Screw.....
1667R	5750	" " Thumb Nut.....
20424	5750	" Eccentric with two 458c.....
458c	5750	" " Set Screw.....
20425	5750	" Gear (back) with two 178f.....
178f	5750	" " " Set Screw.....
20426	5752	" " (front) with two 882c.....
882c	5752	" " " Set Screw.....
20427	5746	" " (intermediate) large.....
20428	—	" " " " 20427 with 9754 and 20429.....
20429	5746	Plaiting Gear (intermediate) small.....
9754	5746	" " " Position Pin..
20430	5746	" " " Stud.....
449c	5746	" " " Set Screw
20491	5751	" " Cover with 20492 and two 402d.....
20492	5751	Plaiting Gear Cover Plate.....
402d	5752	" " " " Screw.....
145d	5752	" " " " Screw.....
20432	5751	" Lever.....
20433	5751	" " Bracket with two 443c...

NO.	PLATE	NAME
141D	5750	Plaiting Lever Bracket Screw.....
20434	5752	“ “ Connecting Rod with two 794E.....
794E	5752	Plaiting Lever Connecting Rod Adjusting Screw.....
199D	5752	Plaiting Lever Connecting Rod Cap Screw
20435	5752	“ “ Hinge Stud.....
443C	5752	“ “ “ “ Set Screw.....
20436	5752	“ Regulating Stud.....
1665J	5752	“ “ “ Nut.....
20437	5752	“ “ “ “ Washer....
43889	5752	“ Rock Shaft.....
20439	5752	“ “ “ Crank with two 200F
200F	5752	“ “ “ “ Set Screw ...
20440	5753	“ “ “ Lever.....
20441	5753	“ “ “ “ Arm .....
20442	5753	“ “ “ “ “ Hinge Stud
155c	5753	“ “ “ “ “ “ “ Set Screw.....
20443	5753	Plaiting Rock Shaft Lever Connecting Rod.....
20444	5753	Plaiting Rock Shaft Lever Connecting Rod Crank with 1961 .....
1961	5753	Plaiting Rock Shaft Lever Connecting Rod Crank Roller and Screw Stud....
1521J	5753	Plaiting Rock Shaft Lever Connecting Rod Crank Roller and Screw Stud Nut
9525	5753	Plaiting Rock Shaft Lever Connecting Rod Crank Roller and Screw Stud Nut Washer.....
66F	5753	Plaiting Rock Shaft Lever Hinge Screw (back).....
66F	5753	Plaiting Rock Shaft Lever Hinge Screw (front).....
32F	5753	Plaiting Rock Shaft Lever Hinge Screw (intermediate).....
12391	767	Presser Bar (hollow).....
20059	5736	“ “ Guide Bracket with 453c....
453c	783	“ “ “ “ Set Screw...
2062	771	“ “ Lifter.....
689c	782	“ “ “ Screw.....
1520J	783	“ “ “ “ Nut.....
12327	770	“ “ Lifting and Releasing Lever Bracket.....
11167	767	Presser Bar Spring (light) .051 wire.....

NOTE: No. 11167 is sent with this machine unless  
another Spring is specified on order.

NO.	PLATE	NAME
12139	2004	Presser Bar Spring (medium) .055 wire ..
20023	2004	“ “ “ (heavy) .063 wire ..
11170	771	“ “ “ Washer.....
20445	5744	“ Foot.....
176D	2038	“ “ Screw.....
688J	783	Pressure Regulating Thumb Screw.....
20446	5754	Separating Blade.....
20447	5751	“ “ Bracket.....
145D	5752	“ “ “ Screw.....
20448	5754	“ “ Holder.....
185H	5754	“ “ “ Screw.....
241D	5754	“ “ Screw.....
2996	771	Shuttle Bobbin.....
62739	—	“ “ Case.....
15140	2013	“ “ “ Latch.....
2973	771	“ “ “ “ Lever.....
2974	771	“ “ “ “ “ Fulcrum Pin.....
2975	771	Shuttle Bobbin Case Latch Spring.....
592E	782	“ “ “ “ Stop Screw ..
15141	—	Shuttle Bobbin Case Hinge, Nos. 2973, 2974 and 15140.....
7553	771	Shuttle Bobbin Case Position Finger....
2523	771	“ “ “ “ “ Rivet
24412	1361	“ “ “ “ Plate.....
391D	1366	“ “ “ “ “ Screw
62740	771	Shuttle Bobbin Case complete, Nos. 591F, 592E, 2523, 2975, 7553, 15141, 15278 and 62739.....
12393	771	Shuttle Body.....
591F	782	“ Tension Regulating Screw.....
15278	771	“ “ Spring.....
19292	771	Shuttle, 1½ in. diam., Nos. 2996, 12393 and 62740.....
*12394	—	Shuttle Driver.....
12444	771	“ “ 12394 with two 1266c....
2049	773	“ “ Pin.....
1266c	5806	“ “ Set Screw.....
2531	767	“ Race Back.....
2532	772	“ “ “ Position Pin.....
2533	767	“ “ “ Spring.....
907D	782	“ “ “ “ Screw.....
24413	—	“ “ Body.....
25000	—	“ “ “ 24413 with 24414 and two 1053D.....
24414	5837	Shuttle Race Cap.....
1053D	2006	“ “ “ Screw.....

NO.	PLATE	NAME
24415	1361	Shuttle Race complete, Nos. 907D, 2531, 2533, 24412, 25000 and two each 391D and 2532.....
145D	782	Shuttle Race Screw.....
20449	—	“ “ Slide.....
4307	772	“ “ Spring.....
50216E	8628	“ “ “ “ Screw.....
20450	5754	Shuttle Race Slide complete, Nos. 4307, 20449 and two 50216E.....
20060	5736	Slack Thread Regulator.....
225F	5736	“ “ “ Adjusting Screw.....
20451	5755	Strip Guide (left).....
20452	5755	“ “ (right).....
20453	5755	“ “ Holder (back).....
20454	5755	“ “ “ (front).....
714D	5755	“ “ Thumb Screw.....
2102	5806	Tension Disc.....
1560C	783	“ Regulating Thumb Nut.....
32572	5806	“ Releasing Disc.....
43944	5806	“ “ Lever.....
12398	773	“ “ “ Hinge Pin.....
12329	772	“ “ “ Spring.....
32574	5806	“ “ Pin.....
50327C	5806	“ Screw Stud.....
44141	—	“ “ “ 50327C with 1560C..
43945	5806	“ Spring.....
44118	—	Tension complete, Nos. 7336, 32572, 32574 43945, 43946, 44141 and two 2102.....
52454	5842	Thread Retainer.....
624C	8628	“ “ Set Screw.....
12404	770	“ Take-up Crank.....
3094	773	“ “ “ Wedge.....
690E	782	“ “ “ “ Screw....
12408	770	“ “ Lever.....
775E	782	“ “ “ Cap Screw....
12166	773	“ “ “ Hinge Pin.....
12409	770	“ “ “ Link.....
11204	770	“ “ “ “ Hinge Pin...
435C	5806	“ “ “ “ “ “ Set Screw.....
12410	—	Thread Take-up Lever complete, Nos. 12166, 12408 and 12409.....
43946	5806	Thread Take-up Spring.....
7336	772	“ “ “ Regulator.....
448C	783	“ “ “ “ Set Screw.....
*43990	—	Thread Take-up complete, Nos. 775E, 11204, 12404, 12410 and 43997.....

NO.	PLATE	NAME
20455	5744	Throat Plate for 20403.....
691R	782	“ “ “ Screw.....
44212	5844	Drip Pan with four 1 in. wire nails, for power table.....

**SINGER Needles should be used  
 in SINGER Machines  
 These Needles and their Containers  
 are marked with the  
 Company's Trade Mark "SIMANCO.\*\*" 1**

**Needles in Containers marked  
 "FOR SINGER MACHINES"  
 are NOT SINGER made needles. 2**



**LIST OF PARTS COMPLETE  
FOR  
MACHINE No. 31-39**

**FOR DARNING LACE CURTAINS. THROAT PLATE WITH SMALL  
NEEDLE HOLE. NO FEED MECHANISM.**

NO.	PLATE	NAME
*44010	—	Arm with 11104.....
8582	773	" Dowel Pin.....
21453	773	" Oil Tube for intermediate bearing..
11119	773	" " " with 52045, for oiling 12408..
21454	773	" " " " " " " " 12409..
52045	8628	" " " Packing (braided cotton) ..
748E	782	" Screw (back).....
854E	783	" " (front).....
12427	766	" Shaft.....
*44172	—	" " 12427 with 20188.....
44192	—	" " 44172 with 20197.....
*11104	—	" " Bushing (front).....
12357	767	" " Flanged Bushing (back).....
448c	783	" " " " " " S e t Screw.....
144D	782	Arm Shaft Screw.....
12480	767	" Side Cap.....
219D	774	" " " Screw.....
12193	2004	" " Cover.....
286D	783	" " " Thumb Screw.....
12403	772	" Spool Pin and Thread Eyelet.....
11241	2003	" " " Washer (cloth).....
12358	2000	Balance Wheel (power) light rim, 2 $\frac{3}{4}$ in. pulley, with two 448c.....
4370	2000	Balance Wheel (stand) heavy rim, 2 $\frac{3}{4}$ in. pulley, with two 448c.....
2135	2000	Balance Wheel (stand) heavy rim, 2 $\frac{1}{2}$ in. pulley, for 3022.....
2862	—	Balance Wheel (stand) heavy rim, 3 in. pulley, for 3022.....
448c	783	Balance Wheel Set Screw.....
*12360	—	Bed.....
256J	2003	Clamp Stop Motion Clamp Screw.....
248A	2011	" " " " Stop Screw..
2020	2003	" " " " Washer.....
*3023	—	" " " Flanged Bushing....
4933	2003	" " " " " " 3023 with two 462c.....

NO.	PLATE	NAME
2022	773	Clamp Stop Motion Flanged Bushing Pin
462c	773	" " " " " " Set Screw.....
3022J	—	Clamp Stop Motion complete, Nos. 248A, 256J, 2020 and 4933.....
20197	2001	Crank Connecting Rod with 20198 and two 896E.....
*20198	—	Crank Connecting Rod Cap.....
896E	773	" " " " " Screw.....
908c	773	" " " " Hinge Screw.....
1619E	773	" " " " " Nut.
12366	—	Face Plate.....
*44181	—	" " Thread Guard (lower).....
12150	773	" " " " 4 4 1 8 1 with 12152.....
12152	773	Face Plate Thread Guard (lower) Rivet..
2827	773	" " " " (upper) with 8505
8505	773	" " " " " Rivet...
12367	2000	Face Plate complete, Nos. 2827, 12150 and 12366.....
190D	782	Face Plate Screw.....
286D	783	" " Thumb Screw.....
43886	5738	Finger Protector.....
129D	5736	" " " Screw.....
14017	5736	" " " Washer.....
12381	767	Needle Bar (hollow).....
*12382	770	" " Connecting Link with 794E.
43997	—	" " " " 12382 and 12384.....
794E	782	Needle Bar Connecting Link Adjusting Screw.....
*12383	—	Needle Bar Connecting Stud.....
1904	770	" " " " Roller (roller only).....
453c	783	Needle Bar Connecting Stud Set Screw..
12384	770	Needle Bar Connecting Stud complete, Nos. 453c, 1904 and 12383.....
20188	767	Needle Bar Crank with 858c and 1065c..
1065c	2011	" " " Position Screw.....
858c	783	" " " Set Screw.....
936E	773	" " Screw Bushing.....
4302	773	" " Thread Guide.....
233D	782	" " " " Screw.....
4303	773	" Clamp with 808F.....
808F	782	" " Screw.....
*24104	2001	Oscillating Rock Shaft.....

NO.	PLATE	NAME
24105	—	Oscillating Rock Shaft complete, Nos. 4784, 12388 and 24104.....
12388	767	Oscillating Rock Shaft Hinge Pin.....
448c	783	“ “ “ “ “ Set Screw
4784	1353	“ “ “ “ Oil Pad.....
12389	766	“ Shaft.....
19496	—	“ “ Crank for 19447.....
44134	—	“ “ “ “ 44135.....
2049	773	“ “ “ Pin.....
457c	783	“ “ “ Set Screw for 19447.....
453c	783	Oscillating Shaft Crank Set Screw for 44135.....
19448	2011	Oscillating Shaft Crank Slide Block.....
226d	1371	“ “ “ “ “ Cap Screw.....
12424	773	Oscillating Shaft Crank Slide Block Cap Screw Washer.....
988c	2011	Oscillating Shaft Crank Slide Block Screw Stud.....
1518j	783	Oscillating Shaft Crank Slide Block Screw Stud Nut.....
19449	2011	Oscillating Shaft Crank Slide Block complete, Nos. 226d, 988c, 12424 and 19448
19447	2011	Oscillating Shaft Crank complete, No. 457c, 1518j, 19449 and 19496.....
44135	5806	Oscillating Shaft Crank complete, Nos. 1518j, 19449, 44134 and two 453c.....
2996	771	Shuttle Bobbin.....
62739	—	“ “ Case.....
15140	2013	“ “ “ Latch.....
2973	771	“ “ “ Lever.....
2974	771	“ “ “ “ Fulcrum Pin.....
2975	771	Shuttle Bobbin Case Latch Spring.....
592f	782	“ “ “ “ Stop Screw.....
15141	—	Shuttle Bobbin Case Hinge, Nos. 2973, 2974 and 15140.....
7553	771	Shuttle Bobbin Case Position Finger.....
2523	771	“ “ “ “ Rivet.....
24412	1361	“ “ “ “ Plate.....
391d	1366	“ “ “ “ Screw.....
62740	771	Shuttle Bobbin Case complete, Nos. 519f, 592e, 2523, 2975, 7553, 15141, 15278 and 62739.....
12393	771	Shuttle Body.....
591f	782	“ Tension Regulating Screw.....

NO.	PLATE	NAME
15278	771	Shuttle Tension Spring.....
19292	771	Shuttle, 1 1/4 in. diam., Nos. 2996, 12393 and 62740.....
*12394	—	Shuttle Driver.....
12444	771	“ “ 12394 with two 1266c.....
2049	773	“ “ Pin.....
1266c	5806	“ “ Set Screw.....
2531	767	“ Race Back.....
2532	772	“ “ “ Position Pin.....
2533	767	“ “ “ Spring.....
907d	782	“ “ “ “ Screw.....
24413	—	“ “ Body.....
25000	—	“ “ “ 24413 with 24414 and two 1053b.....
24414	5837	Shuttle Race Cap.....
1053d	2006	“ “ “ Screw.....
24415	1361	Shuttle Race complete, Nos. 907d, 2531, 2533, 24412, 25000 and two each 391d and 2532.....
145d	782	Shuttle Race Screw.....
12431	—	“ “ Slide.....
4307	772	“ “ “ Spring.....
725e	1387	“ “ “ “ Screw.....
12432	2004	Shuttle Race Slide complete, Nos. 4307, 12431 and two 725e.....
2102	5806	Tension Disc.....
1560c	783	“ Regulating Thumb Nut.....
32572	5806	“ Releasing Disc.....
43944	5806	“ “ Lever.....
12398	773	“ “ “ Hinge Pin.....
12329	772	“ “ “ Spring.....
32574	5806	“ “ Pin.....
50327c	5806	“ Screw Stud.....
44141	—	“ “ “ 50327c with 1560c.....
43945	5806	“ Spring.....
12149	2014	“ Thread Guard.....
44118	—	Tension complete, Nos. 7336, 32572, 32574 43945, 43946, 44141 and two 2102.....
52454	5842	Thread Retainer.....
624c	8628	“ “ Set Screw.....
12404	770	“ Take-up Crank.....
3094	773	“ “ “ Wedge.....
690e	782	“ “ “ “ Screw.....
12408	770	“ “ Lever.....
775e	782	“ “ “ Cap Screw.....
12166	773	“ “ “ Hinge Pin.....
12409	770	“ “ “ Link.....

NO.	PLATE	NAME
11204	770	Thread Take-up Lever Link Hinge Pin...
435c	5806	" " " " " " " Set Screw.....
12410	—	Thread Take-up Lever complete, Nos. 12166, 12408 and 12409.....
43946	5806	Thread Take-up Spring.....
7336	772	" " " " Regulator.....
448c	783	" " " " " Set Screw.....
*43990	—	Thread Take-up complete, Nos. 775E, 11204, 12404, 12410 and 43997.....
12298	—	Throat Plate, large needle hole.....
12422	5743	" " " small needle hole.....
691f	782	" " " Screw.....
44212	5844	Drip Pan with four 1 in. wire nails, for power table.....

**SINGER** Needles should be used  
in **SINGER** Machines  
These Needles and their Containers  
are marked with the  
Company's Trade Mark "SIMANCO.\*\*" 1

Needles in Containers marked  
"FOR SINGER MACHINES"  
are NOT **SINGER** made needles. 2

## LIST OF PARTS COMPLETE FOR MACHINE No. 31-42.

**FOR FLOSSING CORSETS AND ORNAMENTAL STITCHING. STOPS  
AUTOMATICALLY WITH PRESSER RAISED EACH TIME THE  
NEEDLE RISES; NO FEED MECHANISM. THE WORK IS  
MOVED BY HAND TO FORM THE DESIRED ORNAMENT.**

NO.	PLATE	NAME
*43801	—	Arm with 11104.....
8582	773	" Dowel Pin.....
12453	773	" Oil Tube for intermediate bearing...
12454	773	" " " with 52045, for oiling 12167.
11119	773	" " " " " " " 12165.
52045	8628	" " " Packing (braided cotton)...
748E	782	" Screw (back).....
854E	783	" " (front).....
43802	5735	" Shaft.....
*44112	—	" " 43802 with 43803.....
*44200	—	" " 44112 with 20197.....
20321	2048	" " Bushing (back).....
448c	783	" " " " Set Screw.....
*11104	—	" " " (front).....
12193	2004	" Side Cover.....
286D	783	" " " Thumb Screw.....
12403	772	" Spool Pin and Thread Eyelet.....
11241	2003	" " " Washer (cloth).....
*12360	—	Bed.....
20197	2001	Crank Connecting Rod with 20198 and two 896E.....
*20198	—	Crank Connecting Rod Cap.....
896E	773	" " " " Screw.....
908c	773	" " " " Hinge Screw.....
1619E	773	" " " " " Nut.
12313	2049	Driving Pulley.....
12316	5738	" " " Friction Ring (leather)...
12345	5739	" " " " Stop Pin...
1494D	5739	" " " Screw.....
12314	5739	" " " Spring.....
43818	5739	" " " Washer.....
2269	773	" " " " Stop Pin...
12366	—	Face Plate.....
*44181	—	" " " Thread Guard (lower).....
12150	773	" " " " " 44181 with 12152.....

NO.	PLATE	NAME
12152	773	Face Plate Thread Guard (lower) Rivet..
2827	773	" " " " (upper) with 8505.....
8505	773	Face Plate Thread Guard (upper) Rivet..
12367	2000	Face Plate complete, Nos. 2827, 12150 and 12366.....
190D	782	Face Plate Screw.....
286D	783	" " Thumb Screw.....
12381	767	Needle Bar (hollow).....
*12196	5739	" " Connecting Link with 794E..
44008	—	" " " " 12196 with 12131.....
794E	782	Needle Bar Connecting Link Adjusting Screw.....
12131	5739	Needle Bar Connecting Stud with 155c...
155c	5739	" " " " Set Screw...
43803	5738	" " Crank and Lifting Cam with 448c and 1362c.....
1362c	5739	Needle Bar Crank and Lifting Cam Position Screw.....
448c	783	Needle Bar Crank and Lifting Cam Set Screw.....
936E	773	Needle Bar Screw Bushing.....
4302	773	" " Thread Guide.....
233D	782	" " " " Screw.....
4303	773	" Clamp with 808F.....
808F	782	" " Screw.....
*24104	2001	Oscillating Rock Shaft.....
24105	—	Oscillating Rock Shaft complete, Nos. 4784, 12388 and 24104.....
12388	767	Oscillating Rock Shaft Hinge Pin.....
448c	783	" " " " " Set Screw
4784	1353	" " " Oil Pad.....
12389	766	" Shaft.....
19496	—	" " Crank for 19447.....
44134	—	" " " " 44135.....
2049	773	" " " Pin.....
457c	783	" " " Set Screw for 19447
453c	783	" " " " " 44135
19448	2011	" " " Slide Block.....
226D	1371	" " " " " Cap Screw.....
12424	773	Oscillating Shaft Crank Slide Block Cap Screw Washer.....
988c	2011	Oscillating Shaft Crank Slide Block Screw Stud.....

NO.	PLATE	NAME
1518J	783	Oscillating Shaft Crank Slide Block Screw Stud Nut.....
19449	2011	Oscillating Shaft Crank Slide Block complete, Nos. 226D, 988c, 12424 and 19448
19447	2011	Oscillating Shaft Crank complete, Nos. 457c, 1518J, 19449 and 19496.....
44135	5806	Oscillating Shaft Crank complete, Nos. 1518J, 19449, 44134, and two 453c.....
12391	767	Presser Bar (hollow).....
12326	770	" " Guide Bracket with 453c....
453c	783	" " " " Set Screw....
12327	770	" " Lifting and Releasing Lever Bracket.....
12284	5738	Presser Bar Lifting Lever with 448c.....
802D	782	" " " " Hinge Screw....
12285	—	" " " " Lifter.....
12286	5739	Presser Bar Lifting Lever Lifter complete, Nos. 775E, 1976 and 12285.....
800c	5739	Presser Bar Lifting Lever Lifter Adjusting Screw.....
1520J	5739	Presser Bar Lifting Lever Lifter Adjusting Screw Nut.....
801E	5739	Presser Bar Lifting Lever Lifter Hinge Screw.....
1976	5739	Presser Bar Lifting Lever Lifter Roller (roller only).....
775E	782	Presser Bar Lifting Lever Lifter Roller Cap Screw.....
12241	772	Presser Bar Lifting Lever Link.....
766D	782	" " " " " Hinge Screw.....
12240	772	Presser Bar Lifting Lever Pin.....
448c	783	" " " " " Set Screw
12287	5757	" " Spring (light) .0345 wire....
NOTE: No. 12287 is sent with this machine unless another Spring is specified on order		
20363	5757	Presser Bar Spring (heavy) .0405 wire....
11170	771	" " " Washer.....
43804	5740	" " Stop Collar with 1253c.....
1253c	5740	" " " " Set Screw.....
43817	5741	" Foot.....
35599	2669	" " for etching.....
190D	782	" " Screw.....
688J	783	Pressure Regulating Thumb Screw.....
1648E	5740	" " " " Lock Nut.....

NO.	PLATE	NAME
2996	771	Shuttle Bobbin.....
62739	—	“ “ Case.....
15140	2013	“ “ “ Latch.....
2973	771	“ “ “ “ Lever.....
2974	771	“ “ “ “ “ Fulcrum Pin.....
2975	771	Shuttle Bobbin Case Latch Spring.....
592E	782	“ “ “ “ Stop Screw...
15141	—	Shuttle Bobbin Case Hinge, Nos. 2973, 2974 and 15140.....
7553	771	Shuttle Bobbin Case Position Finger.....
2523	771	“ “ “ “ “ Rivet
24412	1361	“ “ “ “ “ Plate.....
391D	1366	“ “ “ “ “ Screw
62740	771	Shuttle Bobbin Case complete, Nos. 591F, 592E, 2523, 2975, 7553, 15141, 15278 and 62739.....
12393	771	Shuttle Body.....
591F	782	“ Tension Regulating Screw.....
15278	771	“ “ Spring.....
19292	771	Shuttle 1 $\frac{1}{8}$ in. diam., Nos. 2996, 12393 and 62740.....
*12394	—	Shuttle Driver.....
12444	771	“ “ 12394 with two 1266c.....
2049	773	“ “ Pin.....
1266c	5806	“ “ Set Screw.....
2531	767	“ Race Back.....
2532	772	“ “ “ Position Pin.....
2533	767	“ “ “ Spring.....
907D	782	“ “ “ “ Screw.....
24413	—	“ “ Body.....
25000	—	“ “ “ 24413 with 24414 and two 1053D.....
24414	5837	Shuttle Race Cap.....
1053D	2006	“ “ “ Screw.....
24415	1361	Shuttle Race complete, Nos. 907D, 2531, 2533, 24412, 25000 and two each 391D and 2532.....
145D	782	Shuttle Race Screw.....
12431	—	“ “ Slide.....
4307	772	“ “ “ Spring.....
725E	1387	“ “ “ “ Screw.....
12432	2004	Shuttle Race Slide complete, Nos. 4307, 12431 and two 725E.....
12318	—	Starting Bell Crank.....
12343	5738	Starting Bell Crank complete, Nos. 12318 to 12320.....

NO.	PLATE	NAME
12312	2049	Starting Bell Crank Bracket with 443c...
12344	—	Starting Bell Crank Bracket complete, Nos. 16c, 1513J, 1517J, 1885, 2018, 12312, 12322, 12323, 12343, 25350 and 44230.....
692D	783	Starting Bell Crank Bracket Screw.....
16c	5740	“ “ “ Hinge Screw.....
1517J	5740	“ “ “ “ “ Nut....
12319	5740	“ “ “ Pitnam Stud.....
25350	5740	“ “ “ “ “ Cotter Pin
2018	1101	“ “ “ “ “ Washer
1885	5740	“ “ “ “ “ Roller with 190D, 1054c and 5968.....
190D	782	Starting Bell Crank Roller Screw.....
1054c	5837	“ “ “ “ “ Stud...
1513J	783	“ “ “ “ “ “ Nut
5968	5837	“ “ “ “ “ Washer.
12320	5740	“ “ “ “ Stop Pin.....
44228	8629	Stop Pawl.....
44230	—	Stop Pawl complete, Nos. 376E, 44228 and 44229.....
12322	5740	Stop Pawl Hinge Pin.....
443c	5740	“ “ “ “ Set Screw.....
12323	5740	“ “ Spring.....
44229	8628	“ “ Wearing Block.....
376E	8628	“ “ “ “ Screw.....
43941	—	“ Wheel with 2269.....
43942	5738	“ “ Block.....
840D	5740	“ “ “ Screw.....
25104	5741	“ “ Pin.....
446c	783	“ “ Set Screw.....
43943	5735	Stop Wheel complete, Nos. 446c, 12316, 12345, 43941, 43942 and two 840D....
2102	5806	Tension Disc.....
1560c	783	“ Regulating Thumb Nut.....
32572	5806	“ Releasing Disc.....
43944	5806	“ “ Lever.....
12398	773	“ “ “ Hinge Pin.....
12329	772	“ “ “ Spring.....
32574	5806	“ “ Pin.....
50327c	5806	“ Screw Stud.....
44141	—	“ “ “ 50327c with 1560c...
43945	5806	“ Spring.....
12149	2014	“ Thread Guard.....
44118	—	Tension complete, Nos. 7336, 32572, 32574, 43945, 43946, 44141 and two 2102....
2455	2014	Thread Retainer Disc.....

NO.	PLATE	NAME
1562J	2014	Thread Retainer Regulating Thumb Nut.
418F	2014	" " Screw Stud.....
43808	5741	" " Spring.....
43809	—	Thread Retainer complete, Nos. 418D, 1562J, 43808 and two 2455.....
12130	5741	Thread Take-up Crank.....
3094	773	" " " Wedge.....
690E	782	" " " " Screw....
12165	5741	" " " Lever.....
775E	782	" " " Cap Screw.....
12166	773	" " " Hinge Pin.....
12167	5741	" " " Link.....
11204	770	" " " " Hinge Pin...
435c	5806	" " " " " " Set Screw.....
12164	—	Thread Take-up Lever complete, Nos. 12165 to 12167.....
*44179	—	Thread Take-up Lever complete, Nos. 775E, 11204, 12130, 12164 and 44008..
43946	5806	Thread Take-up Spring.....
7336	772	" " " Regulator.....
448c	783	" " " " " Set Screw
12298	—	Throat Plate, large needle hole.....
12422	5743	" " " small needle hole.....

NOTE: Nos. 12298 and 12422 are sent with this machine

691F	782	Throat Plate Screw.....
44212	5844	Drip Pan with four 1 in. wire nails, for power table.....

**LIST OF PARTS TO BE USED WITH  
31-42 MACHINE  
WHEN OPERATED HEAD ON**

NO.	PLATE	NAME
19219	1206	Bed Frame Cushion (leather).....
158c	1206	" " " " Screw.....
19220	1206	" " " " Spring.....
19226	1206	" " " " Hinge Connection.....
19398	—	" " " " " 19226 with 211E and 19397.....
19397	1206	Bed Frame Hinge Connection Cap.....
211E	1206	" " " " " " Screw.
16555	1206	" " " " Plate.....
14010	1206	" " " " Rivet.....
20067	819	Bed Frame with two each 16555, 19398 four each 19219, 19220, six each 14010, wood screws 1¼ in. No.12 and eight 158c

NO.	PLATE	NAME
27636	363	Starting Treadle.....
9082	773	" " Bearing Cotter Pin.....
43810	5760	" " Extension.....
51075R	5843	" " " Bolt with 51581R
51581R	5843	" " " " Nut.....
6055	5741	" " " " " Washer
326E	5741	" " " " Screw.....
6055	5741	" " " " " Washer..
43811	5760	" " " Pitman Rod (lower)....
12283	5741	" " " " " Joint
43812	5760	" " " " " (upper)....
12317	5741	" " " " " Joint
43813	5741	" " " " " Clamp with 354c.....
354c	1101	Starting Treadle Pitman Rod Clamp Screw
43814	—	Starting Treadle Pitman complete, Nos. 12283, 12317 and 43811 to 43813.....
25089	5741	Starting Treadle Pitman Cotter Pin.....
11742	5741	" " " " Washer.....
2878	363	" " " Stand.....
43815	—	Starting Treadle complete, Nos. 326E, 2878, 9082, 27636, 43810, 51075R, two 6055 and four wood screws 1 in. No. 16
43816	—	Starting Treadle and Pitman complete, Nos. 11742, 25089, 43814 and 43815...
14229	5760	Table Belt Guide (lower) Bracket with 448c.....
14230	5760	Table Belt Guide (lower) Pulley.....
14231	5757	" " " " " " Shaft with 858c.....
858c	783	Table Belt Guide (lower) Pulley Shaft Oil Hole Plug Screw.....
448c	783	Table Belt Guide (lower) Pulley Shaft Set Screw.....
14232	5760	Table Belt Guide (lower) complete, Nos. 14229 to 14231 and four wood screws 1¼ in. No. 10 R. H. B.....
10857	5760	Table Belt Guide (upper) Bracket with 448c.....
10859	5760	Table Belt Guide (upper) Pulley.....
10858	5757	" " " " " " Shaft...
448c	783	" " " " " " " Set Screw.....
10856	5760	Table Belt Guide (upper) complete, Nos. 10857 to 10859 and three wood screws 1¼ in. No. 12 R. H. B.....

## STARTING TREADLE PARTS

### FOR 31-42 MACHINE

NO.	PLATE	NAME
25082	5760	Treadle.....
28054	5742	“ Centre.....
20039	5760	“ “ Bracket with 28054 and two wood screws 1 in. No. 10.....
12439	—	Treadle Pitman complete, Nos. 12283, 12317, 43813 and two 12281.....
12281	5760	Treadle Pitman Rod.....
43813	5741	“ “ “ Clamp with 354c....
354c	774	“ “ “ “ Screw.....
12317	5741	“ “ “ Joint (connecting stud).....
12283	5741	Treadle Pitman Rod Joint (treadle).....
7958	5741	“ “ Stud Pin.....
11742	5741	“ “ Washer.....
296c	5742	“ Screw Centre.....
46661	—	“ “ “ 296c with 1507R....
20040	5760	“ “ “ Bracket with 46661 and two wood screws 1 in. No. 10.....
1507R	5742	Treadle Screw Centre Nut.....

## MACHINE BASE

NO.	PLATE	NAME
19219	1206	Bed Frame Cushion (leather).....
158c	1206	“ “ “ Screw.....
19220	1206	“ “ “ Spring.....
19226	1206	“ “ Hinge Connection.....
19398	—	“ “ “ “ 19226 with 211E and 19397.....
19397	1206	Bed Frame Hinge Connection Cap.....
211E	1206	“ “ “ “ Screw
16555	1206	“ “ “ Plate.....
14010	1206	“ “ “ “ Rivet.....
20067	819	Bed Frame with two each 16555, 19398, four each 19219, 19220, six each 14010, wood screws 1¼ in. No. 12 and eight 158c.....

## ATTACHMENTS and ACCESSORIES

NO.	PLATE	NAME
51075E	5843	Machine Hinge Bolt with 51581E.....
51581E	5843	“ “ “ Nut.....
6055	5843	“ “ “ “ Washer.....
12361	772	“ “ Connection.....
44139	772	“ “ Plate.....
44140	—	Machine Hinge complete, Nos. 12361, 44139 and Merlized wood screw 1¼ in. No. 14.....
44180	—	Machine Hinge complete, Nos. 6055, 12361, 44139, and 51075E.....
12405	774	Machine Rest (felt).....
28084	—	“ “ Pin.....
41400	6120	“ “ “ (wood) 3½ in. long ..
120342	2045	Oiler (copper plated) with 120343.....
120343	2045	“ Spout, 3½ in. long.....
26026	2045	Screw Driver (machine).....
26485	2045	“ “ (shuttle tension).....
35018	2045	Tape Delivery Wire for 31-37 Machine... ..
8909	2045	Wrench for 1513, 1517, 1518 and 51581..
4822	2045	“ “ 1521 and 1528.....
8908	2045	“ “ 1519, 1520 and 1620.....
19221	2045	“ “ 936, 1516 and 1619.....
22003	2045	“ “ 1550.....
20461	2045	“ “ 1582 and 1668.....
20364	2045	“ “ 1648.....

## BELT GUARDS

NO.	PLATE	NAME
41929	5844	Belt Guard.....
8418	5842	“ “ Button.....
8419	5842	“ “ “ Washer (leather)....
8420	—	“ “ “ 8418 with 8419 and wood screw 1¼ in. No. 9 R. H. B.....
41930	5842	Belt Guard Hinge.....
41931	—	Belt Guard complete, Nos. 8420, 41929 two 41930 and four wood screws ¾ in. No. 9.....

### FOR BENCH STAND

126356	5763	Belt Guard.....
126363	8629	“ “ Bracket.....





**BINDER (Adjustable)****FOR 31-19 MACHINE**

NO.	PLATE	NAME
24344	1267	Feed Dog, 17 teeth (14 teeth to the inch).
*26951	—	Folder (lower).....
*26952	—	“ (upper).....
26953	1379	Folder with Ribbon Tension complete, Nos. 26951, 26952, two each 193F, 7071 and nine 26486.....
193F	1379	Folder Screw.....
7071	1379	“ “ Washer.....
26954	1378	Lifting Presser Foot.....
26486	2022	Ribbon Tension Pin (straight).....
26955	1378	Throat Plate with Extension for 24344...
19376	1378	Vibrating Presser Foot.....
26956	—	Binder complete, Nos. 283D, 19376, 24344 and 26953 to 26955.....
283D	1379	Binder Thumb Screw.....

**BINDER (Adjustable)****FOR CAP FRONTS****FOR 31-20 MACHINE**

NO.	PLATE	NAME
26695	2024	Bed with 9558.....
25698	2024	Folder.....
9558	2038	“ Steady Pin.....
26696	2024	Guide (lower) with 1141D and 9780.....
1141D	5806	“ “ Screw Stud.....
9780	2038	“ “ Stud.....
1566D	2024	“ “ Thumb Nut.....
26697	2024	“ (upper).....
152F	2038	“ Screw.....
7071	2021	“ “ “ Washer.....
25703	2024	Pressure Spring with 26698.....
26698	2024	“ “ Lifting Button.....
334D	2038	“ “ Screw.....
7071	2021	“ “ “ Washer.....
26694	2024	Binder complete, Nos. 334D, 1566D, 25698, 25703, 26695, to 26697, two 152F and three 7071.....

**BINDER (Adjustable)****FOR LEATHER BINDING, CANVAS BAGS,  
LEGGINGS, ETC.**

NO.	PLATE	NAME
36340	5807	Bed with two each 1036c and 1266c.....
36341	5807	Edge Guide.....
671D	5807	“ “ Thumb Screw.....
36342	5807	Guide (lower).....
36343	5807	“ (upper).....
286D	5807	“ Thumb Screw.....
1036c	5806	Leveling Screw (back).....
1266c	5806	“ “ (front).....
36344	5807	Binder complete, Nos. 286D, 671D and 36340 to 36343.....

**BINDER (Adjustable)****FOR SLEEVE FACINGS ON MILITARY COATS**

NO.	PLATE	NAME
120165	5839	Binder on 28971.....
28972	5839	Arm.....
940D	5742	“ Hinge Screw.....
28973	5839	Hinge Plate.....
28971	2669	Shank.....
286D	783	“ Thumb Screw.....
7071	2021	“ “ “ Washer.....
120166	5839	Binder complete, Nos. 286D, 940D, 7071, 28972, 28973 and 120165.....

**BINDER (Adjustable)****FOR GENERAL WORK**

NO.	PLATE	NAME
25657	1949	Bed with 656E and three 447F.....
25662	1949	Binding Guide.....
233D	782	“ “ Set Screw.....
25658	1949	Guide (centre, large) with 589E.....
25659	1949	“ (centre, small) with 589E.....
656E	2038	“ (centre) Screw.....
1566D	2024	“ “ Thumb Nut.....
25660	1949	“ (lower).....
8975	8628	“ “ Rivet.....
25661	1949	“ (upper).....
589E	2038	“ “ Clamping Screw.....
1571D	1949	“ “ “ Thumb Nut....

NO.	PLATE	NAME
207F	2021	Guide (upper) Screw.....
7071	2021	" " " Washer.....
447F	2038	Leveling Screw.....
25663	1949	Presser Foot.....
25664	1949	Binder (adjustable) complete, Nos. 207F, 233D, 1566D, 1571D, 7071, 25657 to 25663 and two 8975.....
152F	782	Binder Screw.....
7071	2021	" " Washer.....

**BINDER (Adjustable)**

TO TURN IN UPPER EDGE ONLY. FOR LIGHT  
OR MEDIUM WEIGHT MATERIAL

NO.	PLATE	NAME
120242	7790	Bed with 1036c.....
120244	7790	Folder (upper).....
120245	7790	Guide (centre).....
120246	7790	" (lower).....
286D	783	" Thumb Screw.....
1036c	7790	Leveling Screw.....
120247	7790	Binder (adjustable) complete, Nos. 286D, 120242 and 120244 to 120246.....
35066	5644	Presser Foot for 120247.....
7298	2014	" " Hinge Pin.....
120143	—	" " Plate.....
19335	—	" " Shank.....
120144	5847	Presser Foot (hinged) complete, for 120247, Nos. 7298, 19335 and 120143..
26603	7696	Feed Dog for 120247, 20 teeth (16 teeth to the inch).....
26605	7696	Throat Plate for 26603.....

**BINDER (Adjustable)**

TO TURN IN BOTH EDGES. FOR LIGHT  
OR MEDIUM WEIGHT MATERIAL

NO.	PLATE	NAME
120242	7791	Bed with 1036c.....
120243	7791	Folder (lower).....
120244	7791	" (upper).....
120245	7791	Guide (centre).....
286D	783	" Thumb Screw.....
1036c	7790	Leveling Screw.....
120248	7791	Binder (adjustable) complete, Nos. 286D and 120242 to 120245.....

NO.	PLATE	NAME
35066	5644	Presser Foot for 120248.....
7298	2014	" " Hinge Pin.....
120143	—	" " Plate.....
19335	—	" " Shank.....
120144	5847	Presser Foot (hinged) complete for 120248, Nos. 7298, 19335 and 120143.....
26603	7696	Feed Dog for 120248, 20 teeth (16 teeth to the inch).....
26605	7696	Throat Plate for 26603.....

**BINDER (English)**

NO.	PLATE	NAME
12425	2021	Feed Dog, 13 teeth (16 teeth to the inch).
25721	2021	Folder.....
207F	2021	" Screw.....
7071	2021	" " Washer.....
25983	2021	Presser Foot.....
26614	2021	Ribbon Tension Pin (bent).....
26615	2021	" " " (straight).....
26616	2021	" " Plate.....
25722	2021	Ribbon Tension complete, Nos. 26614, 26616 and four 26615.....
190D	782	Ribbon Tension Screw.....
7071	2021	" " " Washer.....
26249	2021	Throat Plate for 12425.....
26250	—	Binder complete, Nos. 190D, 207F, 12425, 25721, 25722, 25983, 26249 and two 7071.....

**BINDER (English)**

This Binder is the same as 26250 with the  
following exceptions:

NO.	PLATE	NAME
12370	2692	Feed Dog, 15 teeth (16 teeth to the inch), in place of 12425.....
26465	2692	Throat Plate, large needle hole, for 12370, in place of 26249.....
35741	—	Throat Plate, small needle hole, for 12370, in place of 26249.....
26466	—	Binder complete, Nos. 190D, 207F, 12370, 25721, 25722, 25983, 26465 or 35741 and two 7071.....

**BINDER (English)**

This Binder is the same as 26250 with the following exceptions:

NO.	PLATE	NAME
44252	5813	Feed Dog, 12 teeth (12 teeth to the inch), in place of 12425.
44253	5813	Feed Dog, 16 teeth (16 teeth to the inch), in place of 12425.
28655	1382	Throat Plate, small needle hole, for 44252 and 44253, in place of 26249.
28656	—	Throat Plate, large needle hole, for 44252 and 44253, in place of 26249.
28657	—	Binder complete, Nos. 190D, 207F, 12369 or 12457, 25721, 25722, 25983, 28655 or 28656 and two 7071.

**BINDER (English)****FOR CUT CLOTH**

NO.	PLATE	NAME
19474	2022	Feed Dog, 14 teeth (16 teeth to the inch).
25733	2022	Folder, for 1/2 inch binding.
207F	2021	" Screw.
7071	2021	" Washer.
26400	2022	Presser Foot.
26617	2022	Ribbon Tension Pin (bent).
26486	2022	" " " (straight).
26618	2022	" " Plate.
25734	2022	Ribbon Tension complete, Nos. 26617, 26618 and seven 26486.
190D	782	Ribbon Tension Screw.
7071	2021	" " " Washer.
26401	2022	Throat Plate for 19474.
26402	—	Binder complete, Nos. 207F, 19474, 25733, 25734, 26400, 26401, two 190D and three 7071.

**BINDER (English)**

NO.	PLATE	NAME
26603	1381	Feed Dog, 20 teeth (16 teeth to the inch).
120001	5838	" " (spiked teeth) 12 teeth (10 teeth to the inch).
28334	1380	Folder.
193F	1379	" Screw.
7071	1379	" Washer.

NO.	PLATE	NAME
28676	1381	Presser Foot.
26617	2022	Ribbon Tension Pin (bent).
26486	2022	" " " (straight).
28336	—	" " Plate.
28337	1380	Ribbon Tension complete, Nos. 26617, 28336 and eight 26486.
233D	1380	Ribbon Tension Screw.
28677	1381	Throat Plate for 26603.
28678	—	Binder complete, Nos. 193F, 7071, 26603 or 120001, 28334, 28337, 28676, 28677 and two 233D.

**BINDER (English)****FOR CARPETS**

This Binder is the same as 28678 with the following exceptions:

NO.	PLATE	NAME
12370	1382	Feed Dog, 15 teeth (16 teeth to the inch), in place of 26603.
28775	1382	Throat Plate for 12370, in place of 28677.
28776	—	Binder complete, Nos. 193F, 7071, 12370, 28334, 28337, 28676, 28775 and two 233D.

**BINDER (English)****FOR AWNINGS**

NO.	PLATE	NAME
120434	8211	Feed Dog, 7 teeth (16 teeth to the inch).
120433	8211	Folder.
207F	2021	" Screw.
7071	8211	" Washer.
120435	8211	Presser Foot.
26614	2021	Ribbon Tension Pin (bent).
26615	2021	" " " (straight).
26616	2021	" " Plate.
25722	2021	Ribbon Tension complete, Nos. 26614, 26616 and four 26615.
190D	782	Ribbon Tension Screw.
7071	2021	" " " Washer.
120436	8211	Throat Plate for 120434.
120437	—	Binder complete, Nos. 190D, 207F, 25722, 120433 to 120436 and two 7071.

**BINDER (English)****FOR SLIP COVERS AND GENERAL WORK**

This Binder is the same as 120437 with the following exceptions:

NO.	PLATE	NAME
120458	8211	Presser Foot, in place of 120435 .....
120459	—	Binder complete, Nos. 190D, 207F, 25722, 120433, 120434, 120436, 120458 and two 7071 .....

**BINDER (English)****FOR 31-15 MACHINE**

NO.	PLATE	NAME
120120	5838	Folder with 665D and 120121 .....
120121	5838	" Guide .....
	665D 1388	" " Screw .....
	220D 2038	" " Screw .....
	7806 5838	" " Washer .....
26614	2021	Ribbon Tension Pin (bent) .....
26615	2021	" " " (straight) .....
120122	5838	" " Plate .....
120123	5838	Ribbon Tension complete, Nos. 26614, 120122 and six 26615 .....
	190D 782	Ribbon Tension Screw .....
	7071 2021	" " " Washer .....
120124	5838	Feed Dog, 6 teeth (16 teeth to the inch) .....
120125	5838	Presser Foot .....
120126	5838	Throat Plate for 120124 .....
120127	—	Binder complete, Nos. 220D, 7806, 120120, 120123 to 120126 and two each 190D and 7071 .....

**BINDER (English)****FOR 31-19 MACHINE**

NO.	PLATE	NAME
26699	1314	Feed Dog, 14 teeth (16 teeth to the inch) .....
25744	1314	Folder and Ribbon Tension with nine 26486, for 1/2 in. binding .....
25745	—	Folder and Ribbon Tension with nine 26486, for 3/8 in. binding .....
	671D 1314	Folder and Ribbon Tension Thumb Screw .....
26702	1314	Lifting Presser Foot .....
26486	2022	Ribbon Tension Pin (straight) .....
26700	1314	Throat Plate with Extension for 26699 .....
26703	1314	Vibrating Presser Foot .....
26701	—	Binder complete, Nos. 671D, 25744, 25745, 26699, 26700, 26702 and 26703 .....

**BINDER (English)****FOR 31-19 MACHINE**

This Binder is the same as 26250 with the following exceptions:

NO.	PLATE	NAME
20106	1382	Feed Dog, 13 teeth (16 teeth to the inch) in place of 12425 .....
26702	1314	Lifting Presser Foot, in place of 25983 .....
28783	1382	Throat Plate for 20106, in place of 26249 .....
26703	1314	Vibrating Presser Foot .....
28784	—	Binder complete, Nos. 190D, 207F, 20106, 25721, 25722, 26702, 26703, 28783 and two 7071 .....

**BINDER (English)****FOR CIRCULAR BINDING ON IMITATION LEATHER****FOR 31-19 MACHINE**

NO.	PLATE	NAME
120434	8211	Feed Dog, 7 teeth (16 teeth to the inch) .....
120433	8211	Folder .....
	207F 2021	" " Screw .....
	7071 8211	" " Washer .....
120465	8630	Lifting Presser Foot .....
120436	8211	Throat Plate .....
120466	8630	Vibrating Presser Foot .....
120467	—	Binder (English) complete, Nos. 207F, 7071, 120433, 120434, 120436, 120465 and 120466 .....

**BINDER FOR CIRCULAR BINDING****(BIAS FOLDED STRIPS)****FOR LADIES' LAWN TIES, ETC.**

NO.	PLATE	NAME
28790	2645	Feed Dog, 11 teeth (24 teeth to the inch) .....
28857	2645	Folder .....
	207F 2645	" " Screw .....
	7071 2645	" " Washer .....
28858	2645	Presser Foot with 242D, 23219 and 28859 .....
28859	2645	" " " " Edge Guide .....
23219	2645	" " " " Position Pin .....
	242D 2645	" " " " Screw .....

NO.	PLATE	NAME
28860	2645	Strip Guide.....
207F	2645	" " Screw.....
7071	2645	" " " Washer.....
28792	2645	Throat Plate for 28790.....
28861	—	Binder complete, Nos. 28790, 28792, 28857, 28858, 28860 and two each 207F and 7071

**BINDER FOR CIRCULAR BINDING**

FOR SANDALS, SLIPPERS, SHOE TONGUES, ETC.

FOR 31-19 MACHINE

NO.	PLATE	NAME
28790	2645	Feed Dog, 11 teeth (24 teeth to the inch).
120493	8630	Folder with two 51022J, for ¼ in. to ½ in. gauges.....
120494	8630	Folder with two 1368J, for ⅜ in. to ⅝ in. gauges.....
120495	8630	Folder with two 1368J, for ⅝ in. to 1 in. gauges.....
207F	2645	Folder Screw.....
7071	2645	" " Washer.....
28791	2645	Lifting Presser Foot.....
36620	2645	Ribbon Guide.....
337D	2645	" " Screw.....
7806	2645	" " " Washer.....
28792	2645	Throat Plate for 28790.....
28793	2645	Vibrating Presser Foot.....
28794	—	Binder complete, Nos. 207F, 337D, 7071, 7806, 28790 to 28793, 36620 and 120493, 120494 or 120495.....
1368J	8630	Binder Screw for 120494 and 120495.....
51022J	8630	" " " 120493.....

**BINDER FOR CIRCULAR BINDING**

(BIAS BINDING)

FOR SUSPENDER ENDS AND TABS WITH MOVABLE  
FOLDER FOR FINISHING OFF

FOR 31-19 MACHINE

NO.	PLATE	NAME
28823	2646	Binder on Shank.....
207F	2645	" Screw.....
7071	2645	" " Washer.....
28824	2646	Feed Dog, 6 teeth (24 teeth to the inch).

NO.	PLATE	NAME
28825	2646	Lifting Presser Foot.....
28826	2646	Throat Plate for 28824.....
28827	2646	Vibrating Presser Foot.....
28828	—	Binder complete, Nos. 207F, 7071 and 28823 to 28827.....

**BINDERS (Foot)**

NO.	PLATE	NAME
28665	2606	Binder (foot).....
28666	2606	" " right hand.....
28667	2606	" " left hand.....
36700	5808	" " left.....
28717	1388	" " right.....
35069	2666	" " for strip, to turn the upper edge in, for skirt facings, etc.....
28769	1390	Binder (foot) to turn top only.....

**BINDER (Transverse) ON SHANK**

(WITH TAPE REEL)

FOR WOOLEN COATS

NO.	PLATE	NAME
120532	8631	Binder (transverse) on Shank.....
43525	8631	" Steady Pin.....
51097J	8631	" Thumb Screw.....
3146	1353	" " " Washer.....
26603	1381	Feed Dog, 20 teeth (16 teeth to the inch).
120534	8631	Presser Foot.....
120535	8632	Tape Reel Arm with 11656 and 120537..
11656	8631	" " " Steady Pin.....
51097J	8631	" " " Thumb Screw.....
120536	8632	" " Disc with 120538 and 120539
120537	8632	" " " Pin.....
120538	8632	" " " Stud (wood).....
120539	—	" " " " Sleeve.....
120540	8631	Throat Plate with 43525, for 26603.....
120533	—	Binder (transverse) on Shank complete, Nos. 3146, 26603, 120532, 120534 to 120536, 120540 and two 51097J.....

**BINDERS ON SHANK**

NO.	PLATE	NAME
25705	—	Binder on Shank, for ¾ in. tape.....
25706	—	" " " " ⅞ in. tape.....
25707	2605	" " " " ½ in. tape.....

NO.	PLATE	NAME
25708	—	Binder on Shank for $\frac{1}{8}$ in. tape.....
25709	—	“ “ “ “ $\frac{5}{8}$ in. tape.....
25710	—	“ “ “ “ $\frac{11}{16}$ in. tape.....
25711	—	“ “ “ “ $\frac{3}{4}$ in. tape.....
25712	—	“ “ “ “ $\frac{13}{16}$ in. tape.....
25713	—	“ “ “ “ $\frac{7}{8}$ in. tape.....
25714	—	“ “ “ “ $1\frac{1}{8}$ in. tape.....
25715	—	“ “ “ “ 1 in. tape.....
28611	1396	“ “ “ “ suspender webs.....
28612	1396	Presser Foot for 28611.....
28631	2602	Binder on Shank.....
28632	2602	“ “ “ “ to turn edges under.....
28633	1399	“ “ “ “ top edge only, for binding coats.....
28634	2602	Binder on Shank, to turn top edge only, for raw edge binding.....
28635	1398	Binder on Shank, for $\frac{7}{8}$ in. binding.....
28636	2601	“ “ “ “ to turn top edge only, for men's trouser bottoms.....
28637	2626	Binder on Shank, for bias binding, to turn top edge only, with guide for inserting canvas strip.....
28638	2600	Binder on Shank, for dress shields.....
28639	2603	“ “ “ “ to turn top edge only, for suspenders.....
28640	2627	Binder on Shank, for $1\frac{1}{4}$ in. binding, for soft blankets.....
28641	2603	Binder on Shank, for $\frac{1}{4}$ in. binding.....
28643	2603	“ “ “ “ with Guide (wire) for mattress work.....
28693	2607	Binder on Shank, for binding the arm holes in cotton garments.....
28692	2607	Presser Foot for 28693.....
28704	2610	Binder on Shank.....
28724	2614	“ “ “ “ for binding the neck of knit underwear.....
28938	2658	Presser Foot for 28724.....
28730	2615	Binder on Shank.....
28732	2627	“ “ “ “ to turn under both edges of binding.....
28733	2614	Binder on Shank, for binding corset covers
28734	2615	“ “ “ “ with ribbon guide, for dress shields.....
28765	2622	Binder and Folder on Shank, for folding and binding sleeves.....
28766	2622	Presser Foot for 28765.....

NO.	PLATE	NAME
28910	2659	Binder on Shank.....
28804	2619	“ “ “ “ for binding dress shields
35040	2658	Presser Foot for 28804.....
28751	2618	Binder and Guide on Shank, for binding upper edge of button hole strip and guiding strip and body for shirt waists
28752	2618	Presser Foot for 28751.....
28851	2648	Binder on Shank, for 3 in. strip of bob- binette material, to bind $\frac{3}{4}$ in. wide...
28970	2659	Binder on Shank, for bias binding, to turn both edges under.....
35065	2677	Binder on Shank, for strip, to turn in upper edge only, for skirt facings, etc.....
19474	1258	Feed Dog, 14 teeth (16 teeth to the inch) for 35208.....
19475	1258	Throat Plate for 19474.....
35208	1971	Binder on Shank, to turn in both edges, for bias or straight binding, for skirts, wrappers, shirt waists, etc.....
35066	2682	Presser Foot for 35065 and 35208.....
7298	2014	“ “ “ “ Hinge Pin.....
120143	—	“ “ “ “ Plate.....
19335	—	“ “ “ “ Shank.....
120144	5847	Presser Foot (hinged) complete for 35065 and 35208, Nos. 7298, 19335 and 120143
35082	2680	Binder on Shank, for raw edge bias bind- ing, for wrappers, etc.....
35182	2684	Binder on Shank, for cut strip, with heavy cord stitch in centre of strip, for ladies' dressing sacques, etc.....
35183	1252	Presser Foot for 35182.....
26603	1381	Feed Dog, 20 teeth (16 teeth to the inch) for 28731.....
120001	5838	Feed Dog, 12 teeth (10 teeth to the inch) for 28731.....
35454	2616	Presser Foot for 28731.....
26605	7696	Throat Plate, large needle hole, for 26603
28731	2616	Binder on Shank, to turn under both edges of binding $\frac{1}{8}$ in.....
26603	7696	Feed Dog, 20 teeth (16 teeth to the inch) for 35226.....
120001	5838	Feed Dog, 12 teeth (10 teeth to the inch) for 35226.....
35231	1252	Presser Foot for 35226.....
26605	7696	Throat Plate, large needle hole, for 26603
35226	1972	Binder on Shank, for mattress work.....

NO.	PLATE	NAME
19474	2067	Feed Dog, 14 teeth (16 teeth to the inch) for 35325.....
35066	2067	Presser Foot for 35325.....
7298	2014	" " Hinge Pin.....
120143	—	" " Plate.....
19335	—	" " Shank.....
120144	5847	Presser Foot (hinged) complete for 35325, Nos. 7298, 19335 and 120143.....
24572	2067	Throat Plate, small needle hole, for 19474
35325	2067	Binder on Shank, to turn top edge only, for shirt bosoms, skirt trimmings, etc....
26603	7696	Feed Dog, 20 teeth (16 teeth to the inch) for 35354.....
120001	5838	Feed Dog, 12 teeth (10 teeth to the inch) for 35354.....
35444	—	Presser Foot Body.....
35445	—	" " Tension Plate with 35446...
35446	2669	" " " " Guide Pin....
93F	2669	" " " " Screw.....
2656	2669	" " " " Spring.....
35447	2669	Presser Foot (tension plate) complete for 35354, Nos. 93F, 2656, 35444 and 35445
26605	7696	Throat Plate, large needle hole, for 26603
35352	970	Binder Folder on Shank.....
35353	970	" " Hinge Plate.....
1425B	5742	" " " " Screw.....
2749	5742	" " " " Friction Washer
35354	970	Binder on Shank (hinged) complete, for mattress work, Nos. 1425B, 2749, 35352 and 35353.....
120257	5847	Binder with tension slots on shank, for turning in both edges of bias cut binding, for light or medium weight material

**FOR 31-19 MACHINE**

19474	1258	Feed Dog, 14 teeth (16 teeth to the inch) for corset work, for 35209.....
35210	1252	Lifting Presser Foot for 35209.....
19475	1258	Throat Plate, large needle hole, for 19474
35211	1252	Vibrating Presser Foot for 35209.....
35209	1972	Binder on Shank, to turn in both edges, for bias binding, for binding the inside of small circles, corsets, etc.....
26603	7696	Feed Dog, 20 teeth (16 teeth to the inch) for 35226.....
35232	2674	Lifting Presser Foot for 35226.....
26605	7696	Throat Plate, large needle hole, for 26603

NO.	PLATE	NAME
35233	2674	Vibrating Presser Foot for 35226.....
35226	1972	Binder on Shank, for mattress work.....

**BINDERS (Horn) ON SHANK**

NO.	PLATE	NAME
28619	1399	Binder (horn) on Shank.....
28620	1399	Presser Foot for 28619.....
35067	2678	Binder (horn) on Shank, for strip, to turn both edges in, for ladies' collars, etc....
35066	2682	Presser Foot for 35067.....
7298	2014	" " Hinge Pin.....
120143	—	" " Plate.....
19335	—	" " Shank.....
120144	5847	Presser Foot (hinged) complete, for 35067, Nos. 7298, 19335 and 120143.....
28642	2603	Binder (horn) on Shank.....
28941	2661	" " " " for bias binding, to turn under both edges of binding...
35062	2676	Binder (horn) on Shank, for 7/8 in. to 1 1/2 in. wide, for tape, for mattresses.....
35063	2676	Presser Foot for 35062.....

**BOX PLAITER**

NO.	PLATE	NAME
28343	2632	Centre Guide.....

NOTE: When ordering No. 28343 state width of plait for which it is required.

28344	2632	Centre Guide Holder with 10165.....
190D	782	" " " " Screw.....
7071	2021	" " " " Washer.....
10165	2633	" " Stop Pin.....
28345	2632	Folder Blade (left).....
28346	2632	" " (right).....
401E	2038	" " Screw.....
28347	2632	Sliding Bracket (left).....
28348	2632	" " (right).....
28349	2632	" " Arm (left) with 2301....
28350	2632	" " (right) with 2301...
28351	2632	" " " " Extension Bracket
200F	2633	" " " " " "
		Screw.....
914F	2038	Sliding Bracket Arm Screw.....
26438	2632	" " Cap.....
233D	782	" " " " Screw.....

## BOX PLAITER

NO.	PLATE	NAME
514c	2038	Sliding Bracket Locking Pin.....
26439	2038	" " " Bushing with 468c.....
1564d	2038	Sliding Bracket Locking Pin Head.....
2297	2038	" " " Spring.....
2296	2038	" " " " Bush- ing.....
468c	2038	Sliding Bracket Locking Pin Spring Bush- ing Set Screw.....
2301	5843	Sliding Bracket Stop Pin.....
233d	1375	" " " Screw.....
28352	—	Box Plaiter complete, Nos. 28343 to 28351 two each 190d, 200f, 514c, 914f, 1564d, 2296, 2297, 7071, 26438, 26439, four 401e and six 233d.....

NOTE: When ordering No. 28352 state width of  
plait for which it is required.

28353	2633	Presser Foot with 28354, 28355 and two 665d, for 28352.....
28354	2633	Presser Foot Guide (left).....
28355	2633	" " " (right).....
665d	2633	" " " Screw.....

**CORDERS**

When ordering Corders, or parts thereof, state  
size or number of cords to the inch.

**CORDER (Adjustable)****FOR SHORT TURNS ON CUSHIONS**

NO.	PLATE	NAME
26795	5839	Cord Guide.....
26796	5839	" " Arm with 26798 and three 6037.....
1044d	1377	Cord Guide Arm Hinge Screw.....
120206	5839	" " Bed with 457c.....
457c	5806	" " Leveling Screw.....
26798	5839	" " Bracket.....
6037	1377	" " " Rivet.....
190d	1377	Cord Guide Screw.....
120207	5839	Corder complete, Nos. 190d, 1044d, 26795, 26796 and 120206.....
120001	7696	Feed Dog, 12 teeth (10 teeth to the inch) spiked teeth.....
120208	5838	Presser Foot (grooved).....
26605	7696	Throat Plate, large needle hole, for 120001
26606	—	" " small needle hole, for 120001

**CORDER FOR TOP CORDING**

NO.	PLATE	NAME
25788	2026	Arm with 25789.....
190d	2026	" Adjusting Screw.....
25791	2026	" Bracket.....
25790	2026	" Hinge Pin.....
879d	2026	" Locking Screw.....
25789	2026	" Tip.....
25792	2026	Arm and Bracket complete, Nos. 190d, 879d, 25788, 25790 and 25791.....
12372	778	Feed Dog, 13 teeth (12 teeth to the inch)
25984	2025	Presser Foot.....
12442	778	Throat Plate, small needle hole, for 12372
26328	—	Corder complete, Nos. 12372, 12442, 25792, 25984 and two 135d.....
135d	2026	Corder Screw.....

**CORDER FOR TOP AND BOTTOM CORDING**

This Corder is the same as 26328 with the  
following exceptions:

NO.	PLATE	NAME
26166	2025	Feed Dog, 13 teeth (12 teeth to the inch), in place of 12372.....
26167	2025	Presser Foot, in place of 25984.....
26168	2025	Throat Plate for 26166, in place of 12442.
26169	—	Corder complete, Nos. 25792, 26166 to 26168 and two 135d.....

**CORDER FOR TOP AND BOTTOM CORDING**

This Corder is the same as 26328 with  
the following exceptions:

NO.	PLATE	NAME
28629	1384	Feed Dog, 13 teeth (14 teeth to the inch), in place of 12372.....
26167	2025	Presser Foot, in place of 25984.....
28630	1384	Throat Plate for 28629, in place of 12442
28788	—	Corder complete, Nos. 25792, 26167, 28629, 28630 and two 135d.....

**CORDER (Bow) FOR TOP CORDING**

NO.	PLATE	NAME
26647	2027	Corder Bow.....
4604	2027	" " Rivet.....
25789	2027	" " Tip.....



NO.	PLATE	NAME
26648	2027	Presser Foot.....
26649	2027	Corder (bow) complete, Nos. 4604, 25789, 26647 and 26648.....

**ORDER (Bow) FOR TOP CORDING**

NO.	PLATE	NAME
26937	1385	Corder Bow.....
4604	1385	" " Rivet.....
25789	1385	" " Tip.....
26648	1385	Presser Foot.....
26938	1385	Corder (bow) complete, Nos. 4604, 25789, 26648 and 26937.....

**ORDER FOR EDGE CORDING**

NO.	PLATE	NAME
35026	2673	Corder on Shank.....
35027	2674	Feed Dog, 15 teeth (14 teeth to the inch)
35028	2674	Presser Foot.....
35029	2674	Throat Plate for 35027.....
35030	—	Corder complete, for edge cording plush, Nos. 35026 to 35029.....

**FELLER**

NO.	PLATE	NAME
26403	2029	Feller (foot).....

**FINGER GUARD**

NO.	PLATE	NAME
36818	5809	Finger Guard.....
36819	5809	" " Friction Washer.....
50316j	5809	" " Hinge Screw.....
36820	5809	" " Holder with 196j.....
196j	5809	" " Clamping Screw...
36821	5809	Finger Guard complete, Nos. 36818 to 36820 and 50316j.....

**FINGER GUARD**

120496	5809	Finger Guard.....
120497	5809	" " Holder with 50302j.....
50302j	5809	" " Set Screw.....
236j	5809	" " Screw.....
120498	5809	Finger Guard complete, Nos. 236j, 120496 and 120497.....

**EDGE FOLDERS**

NO.	PLATE	NAME
28615	1397	Edge Folder with Cord Guide on Shank, to insert and sew on insertion in one operation.....
28616	1397	Presser Foot (grooved) for 28615.....
28903	2782	Edge Folder (left hand) with right hand upper guide on Shank, to turn up the body of bobbinette curtains and sew on insertion in one operation.....
28625	2627	Edge Folder (double) with Strip Folder and Cord Tube on Shank, for inserting cord, folding strip and stitching be- tween the two folded edges of goods...
28626	1391	Presser Foot with groove on bottom to the right of needle hole, for 28625.....
28640	2604	Edge Folder (double) on Shank, for men's skeleton coat seams, to turn to outside
28649	2604	Edge Folder on Shank.....
28702	2609	" " " " with Under Strip Edge Folder, for strip when stitched to project over edge of goods.....
28703	2609	Presser Foot for 28702.....
28709	2628	Edge Folder (double) on Shank, for canvas
28735	2616	" " on Shank, for seaming um- brellas.....
28767	2620	Edge Folder (double) on Shank, the under fold to extend $\frac{1}{8}$ in. beyond edge of the upper fold.....
26948	2601	Edge Folder on Shank, to turn edge of yoke and insert body of shirt.....
28753	2618	Edge Folder and Guide on Shank, for top fold only.....
12450	2690	Feed Dog, 11 teeth (18 teeth to the inch), for 35175.....
35176	2690	Presser Foot for 35175.....
12464	2690	Throat Plate, large needle hole, for 12450
12451	2689	" " small needle hole, for 12450
35175	2690	Edge Folder on Shank.....
35255	2693	Feed Dog, 14 teeth (16 teeth to the inch) for 35253.....
35254	2693	Presser Foot for 35253.....
35256	2693	Throat Plate for 35255.....
35253	2693	Edge Folder (double) on Shank, for join- ing yokes to the back of shirts.....

## EDGE FOLDERS

NO.	PLATE	NAME
28958	2668	Edge Folder and Binder (combination) for seaming ladies' skirts and making imitation plait.....
36292	5810	Edge Folder (double) on Shank 28971....
28972	5810	" " Holder.....
35610	2669	" " " Friction Washer....
940F	1366	" " " Hinge Screw.....
28973	5810	" " " Shank.....
28971	2669	" " Shank.....
286D	783	" " Thumb Screw.....
7071	1379	" " " " Washer.....
36293	5810	Edge Folder (double) hinged, adjustable, complete, Nos. 286D, 940F, 7071, 28792, 28973, 35610 and 36292.....
12369	2699	Feed Dog, 12 teeth (12 teeth to the inch), for 36293.....
36294	5810	Presser Foot for 36293.....
12411	2699	Throat Plate for 12369.....
120135	5846	Edge Folder (double) for turning in two edges and inserting loops in one operation.....
120136	5846	Presser Foot for 120135.....
120197	5848	Edge Folder (upper) with lower right hand guide on shank, for military uniforms..

## FOR 31-27 MACHINE

28811	2625	Edge Folder (suspended) right hand, complete, for turning edge and ruffling folded edge on skirts.....
28833	2649	Edge Folder (left hand) on Shank, with right hand upper folder and separating blade.....
28862	2649	Edge Folder (double) on Shank, right hand upper, left hand lower, with separating blade for wrappers.....
28358	2624	Edge Folder (suspended) left hand, to turn edge under.....
28359	1395	Edge Folder (double) with Separating Blade on Shank, lower folder, to turn the edge of the goods under.....
28549	1395	Edge Folder (double) with Separating Blade on Shank, lower folder, to turn the edge of the goods up.....
28756	2619	Edge Folder (left hand) on Shank, with right hand lower guide.....
35922	2619	Ruffling Blade for 28756.....

## EDGE FOLDERS

NO.	PLATE	NAME
28755	2621	Edge Folder (left hand) on Shank, with right hand upper guide and separating blade.....
28758	2620	Edge Folder (double) with Separating Blade on Shank, lower folder, to turn the edges of the goods up.....
28760	2627	Edge Folder (right hand) on Shank, with left hand lower guide.....
28763	2621	Edge Folder (left hand) on Shank, with right hand lower guide.....

## FOR 31-19 MACHINE

NO.	PLATE	NAME
35178	2692	Feed dog, 14 teeth (14 teeth to the inch) ..
35179	2692	Lifting Presser Foot.....
35180	2692	Throat Plate for 35178.....
35181	2692	Vibrating Presser Foot.....
35177	2691	Edge Folder (double) on Shank, for oil cloth and leather.....

## STRIP FOLDERS

NO.	PLATE	NAME
28613	1396	Strip Folder on Shank, for overall shoulder straps.....
28614	1396	Presser Foot for 28613.....
28617	1398	Strip Folder on Shank, for inserting folded strip, for trimming mantles.....
28618	1398	Presser Foot (grooved) for strip, for 28617
28647	2626	Strip Folder on Shank.....
28648	2626	" " " " for making straps
28698	2608	" " " " with cord tube..
28699	2608	Presser Foot (grooved) to the right of needle hole, for 28698.....
28708	2611	Strip Folder on Shank, for folding strip and stitching down centre.....
28764	2622	Strip Folder on Shank, with left hand upper guide.....
28848	2648	Strip Folder on Shank, for folding overall straps.....
28849	1387	Presser Foot with guide on bottom to the left of needle hole, for 28848.....
19474	2067	Feed Dog, 14 teeth (16 teeth to the inch) for 35345.....
35346	2669	Presser Foot for 35345.....
24572	2067	Throat Plate, small needle hole, for 19474

## STRIP FOLDERS

NO.	PLATE	NAME
35345	953	Strip Folder on Shank, for making straps
35347	970	" " (double) hinged, for turning in the right hand edges of strips, for making strip, for 35348.....
35348	970	Strip Folder, for turning in the upper and lower edges of strip, made on 35347.....
35349	970	Strip Folder Holder and Guide.....
190d	782	" " " " " S c r e w
7071	2021	" " " " " "
		Washer.....
19474	1258	Feed Dog, 14 teeth (16 teeth to the inch) for 35351.....
35350	8630	Presser Foot for 35351.....
24572	2067	Throat Plate, small needle hole, for 19474
35351	—	Attachment complete, for making two- piece apron straps, cloth suspenders, etc., Nos. 19474, 24572, 35347 to 35350 and two each 190d and 7071.....
35855	1253	Strip Folder on Shank, for collar bands..
26603	1381	Feed Dog, 20 teeth (16 teeth to the inch) for 35855.....
35856	2669	Presser Foot for 35855.....
26605	7696	Throat Plate, large needle hole, for 26603
28728	2628	Strip Folder on Shank, to turn in the raw edge on lower fold.....
120191	5845	Strip Folder on Shank, to turn in both edges.....
28754	2628	Strip Folder on Shank, for suspender straps, to turn both edges.....
28945	2666	Strip Folder on Shank, for making overall straps.....

## FOR 31-19 MACHINE

NO.	PLATE	NAME
19474	2067	Feed Dog, 14 teeth (16 teeth to the inch)
35322	2697	Lifting Presser Foot.....
24572	2067	Throat Plate, small needle hole, for 19474
35323	2697	Vibrating Presser Foot.....
35324	2684	Strip Folder on Shank, for making four-ply bands, for ladies' stock collars, etc.....

## STRIP FOLDER (Foot)

NO.	PLATE	NAME
28705	2627	Strip Folder with arm.....
28706	2627	" " Hinge Bracket with 448c and 2273.....

## STRIP FOLDERS

NO.	PLATE	NAME
448c	783	Strip Folder Hinge Bracket Set Screw....
96d	2038	" " " Screw.....
26173	2038	" " Lock Stud.....
26174	2038	" " " " Spring.....
228d	2038	" " " " " Screw....
2273	2038	" " Stop Pin.....
28707	2627	Strip Folder (foot, hinged) complete, for folding and stitching plaits on shirt bosom, Nos. 96d, 228d, 26173, 26174, 28705 and 28706.....

## GUIDES

NO.	PLATE	NAME
25866	2045	Guide, for flush throat plate.....
25874	2045	" " raised throat plate.....
35190	2697	" " 28967.....
25873	2045	" (combination).....
28658	1377	" (roller) with 1852.....
1852	1377	" Roller for 28658.....
284b	1366	" Thumb Screw (long).....
732b	1366	" " (short).....
3146	1353	" " " Washer.....
28971	8211	Guide.....
28972	8211	" Holder.....
35610	8211	" " Friction Washer.....
940b	8211	" " Hinge Screw.....
120427	8211	" " Shank.....
286b	8211	" Thumb Screw.....
7071	8211	" " " Washer.....
120428	8211	Guide (adjustable, hinged) complete, Nos. 286b, 940b, 7071, 28971, 28972, 35610 and 120427.....

## EDGE GUIDE

NO.	PLATE	NAME
28838	2650	Edge Guide (suspended) left hand, for 31-27 Machine.....

## EDGE GUIDE (Roller)

NO.	PLATE	NAME
26803	1375	Edge Guide Bed with 2362.....
220b	1375	" " Leveling Screw.....
36760	1375	" " Slide with 26809, 51809 and two 12152.....

NO.	PLATE	NAME
26805	1375	Edge Guide Slide Cap (left).....
207F	1375	" " " " " Screw.....
2362	1375	" " " " " Steady Pin..
26806	1375	" " " " (right).....
207F	1375	" " " " " Screw (large)
233D	1375	" " " " " " (small)
26807	1375	" " " " Lever.....
94D	1375	" " " " " Hinge Screw....
51809	1375	" " " " Roller and Stud.....
26808	1375	" " " " Spring.....
26809	1375	" " " " Cover.....
12152	1375	" " " " " Rivet....
26810	1375	Edge Guide (roller) complete, Nos. 94D, 233D, 26803, 26805 to 26808, 36760, two 207F and four 220D.....
190D	1375	Edge Guide Screw.....

**EDGE GUIDE (Roller)****FOR GLOVE WORK**

NO.	PLATE	NAME
36185	6252	Edge Guide Arm with 1988.....
36186	6252	" " " Friction Washer.....
1425D	6252	" " " Hinge Screw.....
1988	6252	" " " Roller and Screw Stud..
36187	6252	" " " Bed with four 465F.....
465F	6252	" " " Leveling Screw.....
36188	6252	Edge Guide (roller) complete, Nos. 1425D and 36185 to 36187.....

**STRIP GUIDE**

NO.	PLATE	NAME
28712	2612	Strip Guide on Shank.....

**HEMMERS****HEMMER**

**WITH LEVER FOR OPENING THE FOLDER AND RELEASING THE HEM, SO THAT IT CAN BE FINISHED WITHOUT REMOVING THE HEMMER FROM MACHINE. FOR SKIRTS, OVERALLS, OR SIMILAR CLOSED ARTICLES.**

NO.	PLATE	NAME
28679	1376	Hemmer Bed with 28681.....
*28680	1376	" Folder (left).....

NO.	PLATE	NAME
233D	1376	Hemmer Folder (left) Screw.....
2362	1376	" " " Steady Pin.....
28681	1376	" " (right).....
28685	1376	" " Disengaging Lever.....
94D	1376	" " " " Hinge Screw.....
2362	1376	Hemmer Folder Disengaging Lever Stop Pin.....
28682	1376	Hemmer Slide with 28687 and two each 2362 and 12152.....
28683	1376	Hemmer Slide Cap (left).....
28684	1376	" " " (right).....
207F	1376	" " " Screw (back).....
233D	1376	" " " " (front).....
28686	1376	" " Spring.....
28687	1376	" " " Cover.....
12152	1376	" " " Rivet.....
28688	1376	Hemmer complete, Nos. 94D, 28679, 28680, 28682 to 28686, two 207F and three 233D 190D 1376 Hemmer Screw.....
18055	2038	Presser Foot Hinge Pin.....
28689	—	" " Plate.....
28690	—	" " Shank.....
26231	1353	" " Spring.....
28691	1391	Presser Foot (spring hinged) complete, Nos. 18055, 26231, 28689 and 28690.....

**HEMMERS (Foot)**

NO.	PLATE	NAME
28663	2028	Hemmer (foot) $\frac{1}{8}$ in. hem, for 12372, 12455, 20002, 20117 and 20151.....
25919	—	Hemmer (foot) $\frac{1}{8}$ in. hem, for 12372, 12455, 20002, 20117 and 20151.....
25920	2028	Hemmer (foot) $\frac{1}{8}$ in. hem, for 12372, 12455, 20002, 20117 and 20151.....
25921	—	Hemmer (foot) long, $\frac{1}{8}$ in. hem, for shirts, for 12372, 12455, 20002, 20117 and 20151.....
25922	2028	Hemmer (foot) $\frac{1}{8}$ in. hem, for 12369 and 12457.....
25923	—	Hemmer (foot) long, $\frac{1}{8}$ in. hem, for shirts, for 12369 and 12457.....
25924	—	Hemmer (foot) $\frac{1}{4}$ in. hem, for 12369 and 12457.....
26428	2028	Hemmer (foot) $\frac{1}{8}$ in. hem, for 12437 and 20147.....

NO.	PLATE	NAME
36085	—	Hemmer (foot) $\frac{1}{8}$ in. hem, slotted, for lace
28664	—	" " $\frac{3}{8}$ in. hem, slotted, for lace
28662	2028	" " $\frac{1}{8}$ in. hem, slotted, for lace
28661	2028	" " $\frac{3}{8}$ in. hem, for gusset work
28741	2028	" " $\frac{1}{8}$ in. hem, for bagging...
28669	2606	" Spring for 28670.....
26459	5806	" " Rivet.....
28670	2606	" (foot) $\frac{1}{4}$ in. hem, with 28669 and two 26459.....
28742	1388	Hemmer (foot) to make stitch in centre of hem.....
26607	1387	Presser Foot Body for 26610, 26611 and 35016.....
35016	—	Hemmer, $\frac{1}{8}$ in. hem, for 26607.....
26610	1387	" $\frac{1}{8}$ in. hem, for 26607.....
26611	—	" $\frac{3}{8}$ in. hem, for 26607.....
35539	2669	" (foot) $\frac{1}{8}$ in. hem, for China silk, etc.....
120325	8627	Hemmer (foot) $\frac{1}{8}$ in. hem, with guide on bottom to the right of needle hole.....
35710	1252	Hemmer (foot) $\frac{3}{8}$ in. hem, with guide on bottom to the right of needle hole.....
35682	—	Hemmer (foot) $\frac{1}{8}$ in. hem, with guide on bottom to the right of needle hole.....
36524	—	Hemmer (foot) $\frac{5}{8}$ in. hem, with guide on bottom to the right of needle hole.....
35997	—	Hemmer (foot) $\frac{3}{8}$ in. hem, with guide on bottom to the right of needle hole.....
36309	—	Hemmer (foot) $\frac{3}{8}$ in. hem, with guide on bottom to the right of needle hole.....
36072	—	Hemmer (foot) $\frac{1}{4}$ in. hem, with guide on bottom to the right of needle hole.....
35711	1252	Feed Dog, 21 teeth (18 teeth to the inch) for 35712.....
35712	1252	Throat Plate, small needle hole, for 35711, for 35682, 35710, 35997, 36072, 36309, 36524 and 120325.....

NOTE: When ordering No. 35712 state width of hem for which it is required

Nos. 36980 TO 36983 FOR 12437 AND 20147

NO.	PLATE	NAME
36980	—	Hemmer (foot) $\frac{3}{8}$ in. hem.....
36981	—	" " $\frac{5}{8}$ in. hem.....
36982	—	" " $\frac{3}{8}$ in. hem.....
36983	—	" " $\frac{1}{4}$ in. hem.....

### HEMMER (Foot) ADJUSTABLE FOR TENNIS SHOES

NO.	PLATE	NAME
120073	—	Hemmer Block with 39395.....
50441D	5839	" " Hinge Screw.....
39395	5839	" " Pin.....
120074	—	" " Spring.....
651D	2011	" " " Screw.....
120075	—	" Guide.....
50169	5839	" " Screw.....
120076	—	" Plate.....
219D	774	" " Screw.....
120077	—	" Shank.....
120078	5839	Hemmer (foot) adjustable, complete, Nos. 219D, 651D, 50169D, 50441D and 120073 to 120077.....

### HEMMER (Foot) PLAIN BOTTOM

NO.	PLATE	NAME
28795	—	Hemmer (foot) plain bottom, $\frac{1}{8}$ in. hem
26160	—	" " " " $\frac{3}{8}$ in. hem
26161	2028	" " " " $\frac{1}{8}$ in. hem
26162	—	" " " " $\frac{3}{8}$ in. hem
26163	—	" " " " $\frac{1}{4}$ in. hem
6267	2028	" Folder.....
25888	2028	" Tongue.....

NOTE: When ordering Nos. 6267 or 25888, state width of hem and No. of Hemmer for which it is required.

### HEMMERS ON SHANK

NO.	PLATE	NAME
12450	777	Feed Dog, 11 teeth (18 teeth to the inch) for 26655.....
26656	2030	Presser Foot for 26655.....
12464	777	Throat Plate, large needle hole, for 12450
12451	2689	" " small needle hole, for 12450
26652	—	Hemmer, $\frac{3}{8}$ in. hem, for 26655.....
26654	2032	" Rivet.....
26653	2032	" Shank.....
26655	2031	Hemmer on Shank complete, Nos. 26652 to 26654.....
26659	—	Hemmer for 26660.....
26660	2031	Hemmer on Shank complete, $\frac{3}{8}$ in. hem, for umbrella work, Nos. 26653, 26654 and 26659.....

NO.	PLATE	NAME
26661	—	Hemmer (wide) for 26662.....
26662	2031	Hemmer on Shank complete, Nos. 26653, 26654 and 26661.....
26663	—	Hemmer for 26664.....
26664	2030	Hemmer on Shank complete, for raw edge silk, Nos. 26653, 26654 and 26663.....
26665	—	Hemmer, $\frac{1}{8}$ in. hem, for 26666.....
26666	2030	Hemmer on Shank complete, Nos. 26653, 26654 and 26665.....
26934	—	Hemmer (narrow) for 26935.....
26935	1386	Hemmer on Shank complete, Nos. 26653, 26654 and 26934.....
28947	—	Hemmer for 28948.....
28948	1386	Hemmer on Shank complete, for one fold, with right hand lower guide, for lace, Nos. 26653, 26654 and 28947.....
36520	—	Hemmer, $\frac{1}{4}$ in. hem, for 36521.....
36521	5811	Hemmer on Shank complete, Nos. 26653, 26654 and 36520.....
36711	—	Hemmer $\frac{1}{4}$ in. hem, for 36712.....
36712	5811	Hemmer on Shank complete, for umbrella work, Nos. 26653, 26654 and 36711.....
28623	2602	Hemmer and Corder on Shank, to take goods from above to cord bottom.....
28624	2602	Presser Foot with groove on bottom to the right of needle hole, for 28623.....
28627	2600	Hemmer on Shank, for $\frac{3}{8}$ in. hem, for Marseilles quilts.....
28628	2600	Presser Foot for 28627.....
28650	2604	Hemmer on Shank, for hemming heavy Canton flannel.....
28651	2605	Hemmer on Shank, for turning tops and bottoms of canvas leggins.....
28652	2605	Hemmer on Shank, for $1\frac{3}{16}$ in. to 2 in. hem
28653	—	“ “ “ “ $2\frac{3}{16}$ in. to 3 in. hem
28700	2609	“ (short head) on Shank, for hemming stable blankets.....
28701	1391	Presser Foot (tube) for laying braid on stable blankets, for 28700.....
36589	—	Presser Foot for 28700.....
28710	2612	Hemmer on Shank, for $\frac{1}{8}$ in. hem.....
120337	8210	“ “ “ “ $\frac{1}{8}$ in. to $\frac{3}{8}$ in. hem, for bottom of shirt waists.....
28711	2607	Hemmer on Shank, for $\frac{1}{8}$ in. hem, for hemming towels.....
28719	2613	Hemmer on Shank, for $\frac{1}{4}$ in. to $\frac{1}{2}$ in. hem
120287	2613	Hemmer.....

NO.	PLATE	NAME
120288	2613	Hemmer Shank.....
28720	2613	Hemmer on Shank, $\frac{3}{4}$ in. to 1 in. hem, complete, Nos. 120287 and 120288.....
120338	8625	Hemmer, for 120340.....
120339	8625	“ Shank for 120340.....
1443J	8625	“ “ Screw.....
120340	8625	Hemmer on Shank complete, for $\frac{1}{2}$ in. to 2 in. hem, Nos. 120338, 120339 and two 1443J.....
28721	—	Hemmer on Shank, $1\frac{1}{4}$ in. to 2 in. hem...
36776	—	“ “ “ $2\frac{1}{4}$ in. to 3 in. hem...
28722	2613	“ “ “ for heavy woven goods
28723	2614	“ “ “ with guide, for hemming and stitching on lace in one operation.....
120367	8630	Hemmer on Shank, for handkerchiefwork
28736	2617	“ “ “ “ umbrella work...
28737	2615	“ “ “ “ soft material, to turn the hem under.....
28738	2617	Hemmer on Shank, $\frac{3}{8}$ in. hem, to turn the hem under.....
28739	2626	Hemmer on Shank, 3 in. hem, for sheets and pillow slips, to turn the hem under
28935	2661	Hemmer on Shank, for bobbinette material, to turn the hem under.....
35022	1386	Hemmer on Shank, for $\frac{1}{16}$ in. hem, with right hand lower guide for lace.....
35475	976	Hemmer on Shank, for $\frac{1}{2}$ in. hem, with right hand lower guide for lace.....
35023	2672	Hemmer on Shank, for $\frac{1}{16}$ in. hem, with left hand lower guide for lace.....
120452	2672	Hemmer on Shank, for $\frac{1}{2}$ in. to $\frac{1}{8}$ in. gauges, for Windsor ties.....
35064	2631	Hemmer on Shank, for 1 in. to 2 in. hem, for general work.....
35104	2684	Hemmer on Shank, for bottom of shirt waists, for inserting drawing or shirring string.....
35063	2676	Presser Foot, for light work, for 35104...
35832	2669	“ “ “ heavy work, for 35104..
35166	2694	Hemmer on Shank, for 1 in. hem, to turn the goods under.....
120289	2694	Hemmer on Shank, for 2 in. hem, to turn the goods under.....
28614	1396	Presser Foot for 35166.....
19474	2695	Feed Dog, 14 teeth (16 teeth to the inch) for 35236.....

NO.	PLATE	NAME
35063	2676	Presser Foot for 35236.....
19475	2695	Throat Plate for 19474.....
35236	1971	Hemmer on Shank, for $\frac{1}{16}$ in. hem and above, for bottom of shirt waists.....
19474	2695	Feed Dog, 14 teeth (16 teeth to the inch) for 35241.....
35066	2695	Presser Foot for 35241.....
7298	2014	" " Hinge Pin.....
120143	—	" " Plate.....
19335	—	" " Shank.....
120144	5847	Presser Foot (hinged) complete, for 35241, Nos. 7298, 19335 and 120143.....
19475	2695	Throat Plate for 19474.....
35241	2695	Hemmer on Shank, for Canton flannel, etc.
20603	5644	Feed Dog, 20 teeth (16 teeth to the inch) 35863.....
35066	5644	Presser Foot for 35863.....
26605	5644	Throat Plate, large needle hole, for 26603
35863	5644	Hemmer on Shank, for canvas work.....
35679	932	" Folder on Shank for 35681.....
35353	932	" " Hinge Plate for 35681.....
1425D	932	" " " Screw.....
36006	932	" " " " Washer for 35681.....
35681	932	Hemmer on Shank (hinged) complete, for mattress work, Nos. 1425D, 35353, 35679 and 36006.....
26603	932	Feed Dog, 20 teeth (16 teeth to the inch) for 35681.....
35066	932	Presser Foot for 35681.....
26605	932	Throat Plate, large needle hole, for 26603

## FOR 31-27 MACHINE

NO.	PLATE	NAME
28777	2623	Hemmer (double) on Shank, for headings
28778	2623	Presser Foot for 28777.....
28779	2623	Ruffling Blade for 28777.....
35700	976	Hemmer (left hand) with right hand lower guide on Shank.....

## HEMSTITCHER

NO.	PLATE	NAME
28671	1392	Hemstitcher.....

## LAP SEAM FELLER

NO.	PLATE	NAME
28673	2607	Lap Seam Feller (right hand) on Shank, to fold top only.....
28674	2607	Lap Seam Guide on Shank.....

## PRESSER FEET

NO.	PLATE	NAME
25985	2029	Presser Foot (single toe) for gathering...
26638	2029	" " (double toe) for gathering...
26639	—	" " with 228D, for 26641.....
26640	2029	" " Adjustable Guide for 26641
228D	2038	" " " " Screw.....
26641	2029	" " 26639 with Adjustable Guide No. 26640, for tailor work.....
26642	—	Presser Foot.....
26643	2029	" " Guide.....
26644	5843	" " " Hinge Pin.....
26645	5843	" " " Spring.....
337D	1388	" " " " Screw.....
26646	2029	Presser Foot (spring guide) complete, Nos. 337D and 26642 to 26645.....
26650	2029	Presser Foot, for braiding.....
26651	2032	" " " folding umbrella straps
26801	1387	" " Adjustable Guide for 26802
725D	1387	" " " " Screw.....
26802	1387	" " with two adjustable guides, Nos. 26801 and two 725D.....
26936	1387	Presser Foot, for etching.....
26978	1391	" " Graduated Adjustable Guide for 26977.....
335D	1317	Presser Foot, Graduated Adjustable Guide Screw.....
26977	1391	Presser Foot with Graduated Adjustable Guide, No. 26978 and 335D, for tailor work.....
28668	2606	Presser Foot (strip folding).....
28672	1391	" " two grooves to the right of needle hole, for cording.....
28675	1391	Presser Foot (pointed toe) for stitching box plating on body of material.....
28714	2611	Presser Foot (strip folding) for shirt-waist work.....
28715	1391	Presser Foot (tube) for laying fringe-edged braid.....

NO.	PLATE	NAME
28716	2610	Presser Foot (strip folding) for raw edge strip, to turn edges under, for making $\frac{3}{8}$ in. to 1 in. strip.....
35877	—	Presser Foot (strip folding) for raw edge strip, to turn edges under, for making $1\frac{1}{8}$ in. to 2 in. strip.....
28725	1388	Presser Foot Spring Guide.....
665D	1388	" " " " Screw.....
28726	1388	" " (right hand spring guide) with 665D and 28725, for $\frac{3}{8}$ in. to $\frac{1}{4}$ in. gauge.....
NOTE: When ordering Nos. 28725 or 28726 state required distance from edge of goods to seam.		
28743	1388	Presser Foot (grooved) with tube, for cord- ing.....
28744	1389	Presser Foot (strip folding) grooved, with two cord tubes, for making double corded strip.....
28745	1389	Presser Foot (strip folding) to fold both edges of strip.....
28746	1388	Presser Foot (tube) for guiding and stitching the left hand edge of ribbon.....
28747	1389	Presser Foot, bias binding, the velveteen to project $\frac{3}{8}$ in.....
28768	1390	Presser Foot (strip folding) for folding a $2\frac{1}{2}$ in. strip to a 1 in. strip, to be stitched on shirt bosoms for imitation tuck.....
28830	1387	Presser Foot (grooved) for cording, for carriage work.....
28908	2658	Presser Foot Spring Guide for 28909.....
665D	1388	" " " " Screw.....
28909	2658	" " (left hand spring guide) with 665D and 28908.....
28920	1387	Presser Foot, for braiding, to stitch braid on right hand edge.....
28944	2665	Presser Foot (strip folding) for making raw edge straps of bias chiffon.....
35189	2697	Feed Dog, 6 teeth (20 teeth to the inch) for 28967.....
35190	2697	Guide for 28967.....
28964	—	Presser Foot Body.....
28965	2658	" " Knife.....
28966	2658	" " " " Clamp.....
198D	2658	" " " " Screw.....
15072	2658	" " " " Steady Pin....

NO.	PLATE	NAME
28967	2658	Presser Foot complete, for grooving in- soles, Nos. 198D, 15072 and 28964 to 28966.....
35191	2697	Throat Plate, for under braiding, for 35189
62527	5806	Presser Foot Hinge Pin.....
24488	—	" " Plate.....
19223	—	" " Shank.....
24489	5837	Presser Foot (hinged) complete, for heavy work, Nos. 19223, 24488 and 62527....
28770	—	Presser Foot.....
28771	1388	" " Guide.....
15072	1388	" " " Hinge Pin.....
28772	1388	" " " Spring.....
337D	1388	" " " " Screw.....
2113	1388	" " " " Steady Pin....
28773	1388	Presser Foot (spring guide) for gores, Nos. 337D, 2113, 15072 and 28770 ..
35129	2682	Presser Foot (strip folding) for covering cord with folded strip.....
35184	2682	Presser Foot, for darning.....
35172	2682	" " (tube) for guiding and stitch- ing the right hand edge of ribbon.....
35242	2698	Feed Dog, 12 teeth (18 teeth to the inch) for 35243.....
35243	2698	Presser Foot (strip folding) with tube, for inserting cord, for making loops, for dress- ing gowns.....
35244	2698	Throat Plate for 35242.....
35690	1246	Presser Foot (strip folding) for making straps from 1 in. to $1\frac{1}{2}$ in. wide.....
44158	5842	Feed Dog, 15 teeth (14 teeth to the inch)
26276	2038	Presser Foot Hinge Pin.....
44159	—	" " Plate.....
44160	—	" " Shank.....
44161	5842	Presser Foot (hinged) complete, Nos. 26276 44159 and 44160.....
44162	5842	Throat Plate for 44158.....
35995	5645	Presser Foot with right hand folder, for folding and stitching facing to shoe lining.....
36022	5645	Presser Foot with 665D and 36023, for blind stitch cording, for 12 to 40 ligne cord, for ornamental cording on skirts, suits, etc.
36023	5645	Presser Foot Cord Guide for 36022.....

NOTE: When ordering Nos. 36022 or 36023 state the size or send sample of cord for which it is to be used.



NO.	PLATE	NAME
665D	5645	Presser Foot Cord Guide Screw.....
36182	5808	" " with 665D and 36183, for blind stitch braiding, for soutache braid.....
36183	5808	Presser Foot Braid Guide.....
NOTE: When ordering Nos. 36182 or 36183 send sample of braid for which it is to be used.		
665D	1388	Presser Foot Braid Guide Screw.....
36622	5808	" " for 36623.....
36623	5808	" " 36622 with 36576 and two 50202D.....
36576	5808	Presser Foot Finger Guard.....
50202D	5808	" " " " Screw.....

**PRESSER FOOT (Glass Plate)**

NO.	PLATE	NAME
26607	1387	Presser Foot Body.....
26608	1387	" " Plate (glass).....
26609	—	Presser Foot (glass plate) complete, Nos. 26607 and 26608.....

**PRESSER FEET WITH GRADUATED  
ADJUSTABLE GUIDES**

NO.	PLATE	NAME
28949	—	Presser Foot.....
28950	2658	" " Graduated Adjustable Guide
28951	2671	" " " " " "
		Clamping Lever.....
2653	2671	Presser Foot Graduated Adjustable Guide Clamping Lever Hinge Pin.....
28952	2671	Presser Foot Graduated Adjustable Guide Clamping Lever Spring.....
26092	2671	Presser Foot Graduated Adjustable Guide Clamping Lever Spring Rivet.....
28953	2658	Presser Foot with Graduated Adjustable Guide complete, for tailor work, Nos. 2653, 26092 and 28949 to 28952.....
35134	2671	Presser Foot.....
35002	2671	" " Extension.....
35003	2671	" " Graduated Adjustable Guide (long, left).....
35004	2671	Presser Foot Graduated Adjustable Guide (long, right).....
35005	2671	Presser Foot Graduated Adjustable Guide (short, right).....

NO.	PLATE	NAME
35006	2671	Presser Foot Graduated Adjustable Guide (short, right) flush.....
35135	2671	Presser Foot Graduated Adjustable Guide Clamp.....
35136	2671	Presser Foot Graduated Adjustable Guide Clamp Lever.....
337B	2671	Presser Foot Graduated Adjustable Guide Clamp Screw.....
36696	2671	Presser Foot Graduated Adjustable Guide Clamp Steady Pin.....
35137	—	Presser Foot with Extension and Graduated Adjustable Guides complete, Nos. 337B, 35002 to 35006, 35134 to 35136 and 36696.....

**FOR 31-27 MACHINE**

NO.	PLATE	NAME
28761	1390	Presser Foot with 219F and 28762, for stitching ribbon and net material.....
28762	1390	Presser Foot Ribbon Guide.....
219F	774	" " " " Screw.....

**PRESSER FOOT EXTENSIONS**

NO.	PLATE	NAME
12435	780	Presser Foot with 228D.....
62527	5806	" " Hinge Pin.....
20155	—	" " Plate.....
20156	—	" " Shank.....
20157	780	Presser Foot (hinged) complete, Nos. 228D 20155, 20156 and 62527.....
26279	—	Presser Foot Extension, $\frac{1}{8}$ in., for 12435 and 20157.....
26280	—	Presser Foot Extension, $\frac{1}{8}$ in., for 12435 and 20157.....
26281	1387	Presser Foot Extension, $\frac{1}{4}$ in., for 12435 and 20157.....
26282	—	Presser Foot Extension, $\frac{3}{8}$ in., for 12435 and 20157.....
26283	—	Presser Foot Extension, $\frac{1}{2}$ in., for 12435 and 20157.....
228D	2038	Presser Foot Extension Screw for 12435 and 20157.....
44158	5842	Feed Dog, 15 teeth (14 teeth to the inch)
26276	2038	Presser Foot Hinge Pin.....
44159	—	" " Plate.....
44160	—	" " Shank.....

NO.	PLATE	NAME
44161	5842	Presser Foot (hinged) complete, Nos. 26276, 44159 and 44160.....
44162	5842	Throat Plate for 44158.....

**PRESSER FOOT STRIP GAUGE**

NO.	PLATE	NAME
12435	780	Presser Foot with 228D.....
62527	5806	" " Hinge Pin.....
20155	—	" " Plate.....
20156	—	" " Shank.....
20157	780	Presser Foot (hinged) complete, Nos. 228D, 20155, 20156 and 62527.....
25967	1387	Presser Foot Strip Gauge for 12435 and 20157.....
228D	2038	Presser Foot Strip Gauge Screw.....

**PIPING ATTACHMENTS**

NO.	PLATE	NAME
28621	1397	Piping Attachment and Strip Folder on Shank, for car seat cushions.....
28622	1397	Presser Foot (grooved) for 28621.....
28740	2617	Piping Attachment on Shank.....
28803	2619	" " " " for flannel, without cord.....
28974	2661	Piping Attachment on Shank.....
28975	2658	Presser Foot for 28974.....
44253	5813	Feed Dog, 16 teeth (16 teeth to the inch) for 35245.....
35246	2699	Presser Foot for 35245.....
44256	—	Throat Plate for 44253.....
35245	2699	Piping Attachment on Shank.....
36129	5812	" " (double adjustable) on Shank with upper edge folder.....
36131	5812	Presser Foot for 36129.....

**QUILTERS**

NO.	PLATE	NAME
28659	1392	Quilter Guide for 28660.....
25992	1392	" " Holder with two 207F, for 25992.....
207F	2021	Quilter Guide Holder Set Screw.....
207F	2021	" " Set Screw.....
28660	1392	Quilter complete, Nos. 25992 and 28659..

NO.	PLATE	NAME
120479	8212	Quilter Guide (left).....
120480	8212	" " (right).....
120481	8212	" " Bracket.....
120482	—	" " " 120481 with 120483 and two 209c.....
120483	8212	Quilter Guide Disengaging Sleeve.....
120484	8212	" " " " Spring.....
602D	8628	" " " " " Screw.....
209c	8628	Quilter Guide Set Screw.....
120485	—	Quilter complete, Nos. 602D, 120479, 120480, 120482 and 120484.....

**RUFFLERS****RUFFLER (Power)**

NO.	PLATE	NAME
26005	984	Driving Lever.....
69D	5742	" " Hinge Screw.....
35019	984	" " Spring.....
1666D	984	" " " Adjusting Nut.....
26007	984	Foot.....
207F	2021	" Screw.....
26016	984	Frame.....
26017	984	Needle Clamp with 808F.....
808F	782	" " Screw.....
26010	984	Ruffling Blade with S505.....
811D	5742	" " Hinge Screw.....
26011	984	" " Lever with 26189 and 26629.....
812D	984	" " " Adjusting Thumb Screw.....
1621E	984	Ruffling Blade Lever Adjusting Thumb Screw Nut.....
26629	2014	Ruffling Blade Lever Protector.....
26189	2014	" " " " Rivet....
8505	773	" " Rivet.....
26018	984	Ruffler complete, Nos. 69D, 207F, 811D, 812B, 1621E, 1666D, 26005, 26007, 26010, 26011, 26016, 26017 and 35019.....
24303	1344	Feed Dog, 6 teeth (14 teeth to the inch) ..
24306	1344	Throat Plate for 24303.....

**RUFFLER (Power)**

NO.	PLATE	NAME
25997	984	Driving Lever.....
69D	5742	" " Hinge Screw.....

NO.	PLATE	NAME
25998	984	Driving Lever Spring.....
1582 <sub>D</sub>	984	" " " Adjusting Nut.....
25993	984	Frame with 25994 to 25996 and 26001....
25995	2014	" Block.....
25996	2014	" " Rivet.....
25994	2014	" Stud.....
207 <sub>F</sub>	2021	" " Set Screw.....
26718	1370	Needle Clamp Body.....
1943	1370	" " Roller.....
1115 <sub>F</sub>	1370	" " Screw.....
26719	984	Needle Clamp complete, Nos. 1115 <sub>F</sub> , 1943 and 26718.....
25999	984	Ruffling Blade.....
26002	2014	" " Clamp.....
337 <sub>D</sub>	1388	" " " Screw.....
26000	984	" " Lever.....
560 <sub>B</sub>	984	" " Adjusting Thumb Screw.....
1603 <sub>E</sub>	984	Ruffling Blade Lever Adjusting Thumb Screw Nut.....
26001	2014	Ruffling Blade Lever Stop Pin.....
26229	984	" Presser Foot.....
26230	984	Ruffler complete, Nos. 69 <sub>D</sub> , 207 <sub>F</sub> , 560 <sub>B</sub> , 1582 <sub>D</sub> , 1603 <sub>E</sub> , 25993, 25997 to 26000, 26002, 26229, 26719 and two 337 <sub>D</sub> .....

### RUFFLER (Power)

WITH RIGHT AND LEFT GUIDES WITH SEPARATING BLADES  
AND DISENGAGING LEVER TO THROW RUFFLING BLADE  
OUT OF ACTION.

NO.	PLATE	NAME
26722	2035	Driving Lever.....
1101 <sub>C</sub>	2035	" " Hinge Screw.....
26668	2035	" " Spring.....
1640 <sub>C</sub>	2035	" " Adjusting Nut.....
26669	2035	Frame.....
26670	2034	Guide (left) with 26679 and two 662 <sub>D</sub> ....
26671	2035	" (right) with 26679 and two 662 <sub>D</sub> ..
223 <sub>D</sub>	2035	" Screw.....
26718	1370	Needle Clamp Body.....
1943	2034	" " Roller.....
1115 <sub>F</sub>	2034	" " Screw.....
26719	2034	Needle Clamp complete, Nos. 1115 <sub>F</sub> , 1943 and 26718.....
26675	2035	Ruffling Blade.....

NO.	PLATE	NAME
26676	2035	Ruffling Blade Clamp.....
337 <sub>D</sub>	2035	" " " Screw.....
26723	2034	" " Lever.....
812 <sub>B</sub>	2035	" " " Adjusting Thumb Screw.....
1621 <sub>E</sub>	2035	Ruffling Blade Lever Adjusting Thumb Screw Nut.....
26678	2035	Ruffling Blade Lever Disengaging Lever
102 <sub>D</sub>	2035	" " " " "
		Hinge Screw.....
2301	2035	Ruffling Blade Lever Disengaging Lever Stop Pin.....
26679	2035	Separating Blade.....
662 <sub>D</sub>	2035	" " Screw.....
26724	2034	Ruffler complete, Nos. 102 <sub>D</sub> , 223 <sub>D</sub> , 812 <sub>A</sub> , 1101 <sub>C</sub> , 1621 <sub>E</sub> , 1640 <sub>C</sub> , 2301, 26668 to 26671, 26675, 26676, 26678, 26719, 26722, 26723 and two 337 <sub>D</sub> .....

### RUFFLER (Power)

WITH LEVER FOR THROWING RUFFLING BLADE INTO ACTION,  
FOR INTERMITTENT RUFFLING, SUCH AS YOKING  
SHIRTS, ETC.

NO.	PLATE	NAME
28590	1371	Driving Lever.....
1101 <sub>C</sub>	1371	" " Hinge Screw.....
1647 <sub>C</sub>	1371	" " " " Nut.....
28591	1371	" " Spring.....
28592	1371	" " " Collar.....
28593	1371	Frame.....
26718	1370	Needle Clamp Body.....
1943	1370	" " Roller.....
1115 <sub>F</sub>	1370	" " Screw.....
26719	1370	Needle Clamp complete, Nos. 1115 <sub>F</sub> , 1943 and 26718.....
28594	1371	Presser Foot (left).....
185 <sub>H</sub>	1371	" " " Screw.....
62527	5806	" " (right) Hinge Pin.....
28813	1371	" " Plate.....
28596	1371	" " " Shank.....
28597	1371	" " " " Cap.....
198 <sub>D</sub>	1371	" " " " Screw...
2656	1371	" " " " Spring.....
706 <sub>D</sub>	1371	" " " " Stop Screw...
2521	1371	" " " Spring.....

## RUFFLERS

NO.	PLATE	NAME
28814	—	Presser Foot (right) complete, Nos. 2521, 28596, 28813 and 62527.....
28815	1371	Ruffling Blade.....
24203	1371	“ “ Holder.....
226D	1371	“ “ “ Cap Screw.....
24204	1371	“ “ “ Spring.....
24205	1371	“ “ “ Stop.....
24206	1371	“ “ “ Stud.....
1550H	1371	“ “ “ Nut.....
28607	1371	“ “ “ Stop.....
28600	1371	“ “ Lever.....
560B	1371	“ “ “ Adjusting Thumb Screw.....
1603E	1371	Ruffling Blade Lever Adjusting Thumb Screw Nut.....
1049D	1371	Ruffling Blade Lever Stop Screw.....
665D	1371	“ “ Screw.....
28601	1371	Starting Lever with 190D.....
190D	1371	“ “ Clamping Screw.....
28816	1370	Ruffler complete, Nos. 185H, 226D, 560B, 706D, 1049D, 1101C, 1550H, 1603E, 1647C, 2656, 24203 to 24206, 26719, 28590 to 28594, 28597, 28600, 28601, 28607, 28814, 28815, two 665D and three 198D.....
28603	1370	Feed Dog, 10 teeth (16 teeth to the inch) for 28816.....
28817	1370	Throat Plate for 28603.....
28605	1372	Edge Folder (upper, right hand) with left hand lower guide and separating blade on shank, to fold top band only, for making yokes, for 28816.....
28818	1372	Double Edge Folder (right hand) with separating blade, for ruffling shirt body and putting in yokes, for 28816.....

## SEAMERS

NO.	PLATE	NAME
26657	—	Seamer, for umbrella work.....
26361	—	“ Edge Guide.....
26654	2032	“ Rivet.....
26653	2032	“ Shank.....
26658	2032	Seamer complete, Nos. 26361, 26653, 26654 and 26657.....

## SEPARATING BLADE (Hinged)

FOR 31-27 MACHINE

NO.	PLATE	NAME
35279	2062	Separating Blade.....
35272	2061	“ “ Arm.....
35273	2061	“ “ “ Bracket.....
76D	2061	“ “ “ Hinge Screw.....
35274	2061	“ “ “ Latch Lever with 35275.....
102D	2061	Separating Blade Arm Latch Lever Hinge Screw.....
10135	2061	Separating Blade Arm Latch Lever Spring
239D	2061	“ “ “ “ “ “ “ Screw.....
35275	2061	Separating Blade Arm Latch Lever Stud.
35276	2061	“ “ “ Holder.....
102D	2061	“ “ “ Hinge Screw...
35277	2061	“ “ “ Spring.....
108D	2061	“ “ “ “ Screw...
4604	2061	“ “ “ “ Stop Pin
14026	2061	“ “ “ Stop Pin.....
337D	2061	“ “ “ Screw.....
35280	—	Separating Blade (hinged) complete, Nos. 76D, 108D, 4604, 10135, 14026, 35272 to 35274, 35276, 35277, 35279, two each 102D, 239D and 337D.....
35283	2062	Edge Folder (lower) right hand, on Shank
35284	2064	“ “ (upper) left hand.....
217F	2061	“ “ “ Screw.....
35282	2064	“ Guide (upper) left hand.....
217F	2061	“ “ “ Screw.....
35285	2062	Presser Foot.....
35286	2062	Ruffling Blade.....

## THROAT PLATES

NO.	PLATE	NAME
12450	1383	Feed Dog, 11 teeth (18 teeth to the inch)
28342	1383	Throat Plate with 337D and 26080, for 12450, for under braiding.....
26080	1383	Throat Plate Needle Hole Plate for 26760 and 28342.....
337D	1383	Throat Plate Needle Hole Plate Screw...
44252	5813	Feed Dog, 12 teeth (12 teeth to the inch)
44253	5813	“ “ 16 teeth (16 teeth to the inch)

## THROAT PLATES

NO.	PLATE	NAME
28654	1383	Throat Plate, for under braiding, for 44252 and 44253.....
26760	1383	Throat Plate, with 337D and 26080, for under braiding, for 44252 and 44253...
19474	5813	Feed Dog, 14 teeth (16 teeth to the inch)
36906	5813	Throat Plate with under guide, for rick rack, for 19474.....

## TUBULAR TRIMMING ATTACHMENT

NO.	PLATE	NAME
35879	5643	Strip Wire.....
35880	5643	Feed Dog, 6 teeth (16 teeth to the inch)..
35881	5643	Presser Foot (strip folding) with tube....
35018	5643	Tape Delivery Wire.....
35882	5643	Throat Plate for 35880.....
35883	—	Tubular Trimming Attachment complete, for making $\frac{1}{8}$ in., $\frac{3}{16}$ in. and $\frac{1}{4}$ in. trimmings, Nos. 35018 and 35879 to 35882

NOTE: When ordering No. 35883, state size required.

## TUCKER

NO.	PLATE	NAME
36655	8213	Driving Lever
36656	8213	" " Hinge Stud.....
36657	8213	" " Lock Spring.....
36658	8213	" " " " Rivet.....
120500	8213	Frame.....
26718	1370	Needle Clamp Body.....
1943	1370	" " Roller.....
1115F	1370	" " Screw.....
26719	984	Needle Clamp complete, Nos. 1115F, 1943 and 26718.....
36660	8213	Tuck Guide.....
50238B	8213	" " Thumb Screw.....
36661	8213	" " " " Washer.....
36662	8213	" Marker (lower).....
36663	—	" " " 36662 with 36664 and two 36648.....
36664	8213	Tuck Marker (upper).....
120572	8213	" " Clamping Plate.....
50238B	8213	" " " " T h u m b Screw.....
36648	8213	Tuck Marker Rivet.....
36667	8213	" Smoothing Spring.....

## TUCKER

NO.	PLATE	NAME
86354	8213	Tuck Smoothing Spring Rivet.....
36561	8213	Tucker complete, Nos. 26719, 36655 to 36657, 36660, 36661, 36663, 36667, 120500, 120572 and two each 36658, 50238B and 86354.....

## TUCKER (Power)

NO.	PLATE	NAME
26099	2037	Bed.....
26100	2037	Cloth Guide.....
291D	2038	" " Thumb Screw.....
26101	2037	" " Slide with 26102 and two 26092.....
4604	2038	Cloth Guide Slide Rivet.....
401E	2038	" " " Screw.....
36378	2037	Leveling Plate.....
12143	2037	Presser Foot.....
26368	2037	Tuck Marking Bar.....
26369	—	Tuck Marking Bar complete, Nos. 26368 and 26370 to 26372.....
26105	2037	Tuck Marking Bar Bracket.....
26106	2038	" " " " Hinge Pin....
220D	2038	" " " " " " " Set Screw.....
26107	2037	Tuck Marking Bar Lifting Spring.....
26108	2037	" " " Pressure Spring.....
26109	2037	" " " " " Clamp with 196F.....
196F	2038	Tuck Marking Bar Pressure Spring Clamp Set Screw.....
334D	2038	Tuck Marking Bar Set Screw.....
26370	2038	" " Pin.....
26371	2038	" " " Guide Pin.....
26372	2038	" " " Spring.....
26102	2037	" " Plate.....
26092	2038	" " " Rivet.....
26111	2037	" Smoothing Spring.....
4604	2038	" " " Rivet.....
26377	2037	Tucker complete, Nos. 220D, 291D, 334D, 401E, 12143, 26099 to 26101, 26105 to 26109, 26111, 26369, 26378 and three 4604.....
176D	2038	Tucker Screw.....

**TUCKER (Long Arm)**

NO.	PLATE	NAME
26568	2635	Edge Guide.....
26569	2635	“ “ Slide.....
287D	783	“ “ “ Thumb Screw.....
7071	2021	“ “ “ “ Washer.....
939D	5843	“ “ Thumb Screw.....
26597	—	Edge Guide complete, Nos. 287D, 7071, 26568 and 26569.....
26686	8630	Presser Foot.....
26570	2634	Tuck Guide Plate.....
26571	2634	“ “ “ Arm with 5944.....
58D	782	“ “ “ “ Hinge Screw.....
26684	2634	“ “ “ Bracket.....
732D	1366	“ “ “ “ Thumb Screw.....
5944	5843	“ “ “ Guide Pin.....
287D	783	“ “ “ Thumb Screw.....
7071	2021	“ “ “ “ Washer.....
26683	—	Tuck Guide Plate complete, Nos. 58D, 287D, 732D, 7071, 26570, 26571, 26684 and two wood screws 1 in. No. 12.....
26685	—	Tucker complete, Nos. 939D, 26597, 26683 and 26686.....

NOTE: Bed Frame 20067 is used with, but not included in, 26685.

**WELT GUIDE****(ADJUSTABLE) WITH SWITCH**

NO.	PLATE	NAME
26143	2039	Bed.....
26144	2039	Cap.....
238D	2039	“ Screw.....
26145	2039	Carrier.....
26146	—	“ Slide.....
26344	2039	“ “ Stop.....
240D	2039	“ “ “ Adjusting Screw.....
26147	2039	“ Tongue.....
26148	—	Carrier complete, Nos. 233D, 26145 to 26147 and 26149.....
26138	2039	Carrier Slide Switch Cam with Shaft.....
26139	2039	“ “ “ “ Shaft Head with Lever with 337D.....
337D	2039	Carrier Slide Switch Cam Shaft Head Set Screw.....
910F	2039	Welt Guide Adjusting Screw.....

NO.	PLATE	NAME
26149	2039	Width Guide.....
233D	2039	“ “ Screw.....
26150	2039	Welt Guide complete, Nos. 240D, 910F, 26138, 26139, 26143, 26144, 26148, 26344 and three 238D.....
190D	782	Welt Guide Screw.....
7071	2021	“ “ “ Washer.....
26681	2039	Presser Foot.....
1928	2039	Roller, 1¼ in. diam., fine, with 386D and 1528D.....
16573	2039	Roller Arm.....
386D	5842	“ “ Screw.....
1528D	5842	“ “ “ Nut.....
19394	—	Roller Presser complete, 1¼ in. fine roller, Nos. 1928 and 16573.....

NOTE: Presser Foot 26681 and Roller Presser 19394 are used with, but not included in, 26150

**BOBBIN WINDERS****BOBBIN WINDER****FOR 4370**

NO.	PLATE	NAME
15072	2014	Bobbin Position Pin.....
12168	2003	Bracket.....
692D	783	“ Screw.....
12169	2003	Frame.....
12171	2003	Frame complete, Nos. 333D, 5960, 5961, 5963, 12169 and 15077.....
32D	782	Frame Hinge Screw.....
5960	768	Friction Wheel (leather).....
5961	768	“ “ Washer.....
333D	782	“ “ “ Screw.....
15077	773	Spindle with 15072.....
5963	768	“ Flange.....
12170	773	Spring.....
180F	782	“ Screw.....
12172	—	Bobbin Winder complete, Nos. 32D, 180F, 12168, 12170 and 12171.....

**BOBBIN WINDER****FOR 2135 AND 2862**

This Bobbin Winder is the same as 12172 with the following exceptions:

NO.	PLATE	NAME
12201	2003	Frame complete, Nos. 333D, 5960, 5961, 5963, 12169 and 15077, in place of 12171
12202	—	Bobbin Winder complete, Nos. 32D, 180F, 12168, 12170 and 12201.....

**BOBBIN WINDER****FOR 12358**

This Bobbin Winder is the same as 12172 with the following exceptions:

NO.	PLATE	NAME
20307	2020	Frame, in place of 12169.....
20308	—	Frame complete, Nos. 333D, 5960, 5961, 5963, 15077 and 20307, in place of 12171
20309	—	Bobbin Winder complete, Nos. 32D, 180F, 12168, 12170 and 20308.....

**BOBBIN WINDER****(HAMBURG)****FOR 2135 AND 2862**

This Bobbin Winder is the same as 12172 with the following exceptions:

NO.	PLATE	NAME
43981	6119	Frame, in place of 12169.....
43982	6119	Frame complete, Nos. 5960, 5961, 5963, 12336, 15077 and 43981, in place of 12171.....
12336	2003	Spindle for spool, in place of 333D.....
12337	—	Bobbin Winder complete, Nos. 32D, 180F, 12168, 12170 and 43982.....

**BOBBIN WINDER****(HAMBURG)****FOR 4370**

This Bobbin Winder is the same as 12172 with the following exceptions:

NO.	PLATE	NAME
43981	6119	Frame, in place of 12169.....

**BOBBIN WINDERS**

NO.	PLATE	NAME
43983	6119	Frame complete, Nos. 5960, 5961, 5963, 12336, 15077 and 43981, in place of 12171
12336	2003	Spindle for spool, in place of 333D.....
20498	—	Bobbin Winder complete, Nos. 32D, 180F, 12168, 12170 and 43983.....

**BOBBIN WINDER****(SWINGING AUTOMATIC, RIGHT HAND)****FOR 2996****FOR POWER TABLE**

NO.	PLATE	NAME
27552	1162	Base.....
15072	2014	Bobbin Position Pin.....
27302	1162	Frame.....
50356D	5806	" Hinge Screw.....
1620J	5806	" " " Nut.....
27303	773	" Spring.....
27553	1162	Pulley.....
*27849	—	Spindle.....
27538	1162	" 27849 with 15072, 27850 and 41828
*27850	—	" Collar.....
41828	—	" " Pin.....
27306	1162	Spool Pin.....
27307	1162	" Stand.....
27308	1162	Spool Stand complete, Nos. 418E, 1562J, 2106, 10141, 11241, 27306, 27307 and two each 2455 and wood screws 1 in. No. 10
11241	2003	Spool Washer (cloth).....
27312	2003	Stop Latch.....
35D	2011	" " Hinge Screw.....
2455	2014	Tension Disc.....
1562J	2014	" Regulating Thumb Nut.....
418E	2014	" Screw Stud.....
10141	2014	" Spring.....
2106	2014	" Thread Guide.....
27650	—	Bobbin Winder, Nos. 35D, 1620J, 27302, 27303, 27312, 27538, 27552, 27553, 50356D and two wood screws 1 in. No. 7
27554	—	Bobbin Winder (swinging automatic, right hand) complete, Nos. 27308 and 27650

**BOBBIN WINDER**  
(SWINGING AUTOMATIC, RIGHT HAND)  
FOR 2996  
FOR STAND

This Bobbin Winder is the same as 27554 with the following exceptions:

NO.	PLATE	NAME
27540	2445	Base, in place of 27552.....
27541	2445	Pulley, in place of 27552.....
27647	2445	Bobbin Winder, Nos. 35D, 1620J, 27302, 27303, 27312, 27538, 27540, 27541, 50356D and two wood screws 1 in. No. 7, in place of 27650.....
27544	—	Bobbin Winder (swinging automatic, right hand) complete, Nos. 27308 and 27647

**BOBBIN WINDER**  
(SWINGING AUTOMATIC, RIGHT HAND)  
FOR 19131  
FOR POWER TABLE

This Bobbin Winder is the same as 27554 with the following exceptions:

NO.	PLATE	NAME
27587	1162	Stop Latch, in place of 27312.....
27651	1162	Bobbin Winder, Nos. 35D, 1620J, 27302, 27303, 27538, 27552, 27553, 27587, 50356D and two wood screws 1 in. No. 7, in place of 27650.....
27588	—	Bobbin Winder (swinging automatic, right hand) complete, Nos. 27308 and 27651

**BOBBIN WINDER**  
(SWINGING AUTOMATIC, RIGHT HAND)  
FOR 19131  
FOR STAND

This Bobbin Winder is the same as 27554 with the following exceptions:

NO.	PLATE	NAME
27540	2445	Base, in place of 27552.....
27541	2445	Pulley, in place of 27553.....
27587	1162	Stop Latch, in place of 27312.....
27875	—	Bobbin Winder, Nos. 35D, 1620r, 27302, 27303, 27538, 27540, 27541, 27587, 50356D, and two wood screws 1 in. No. 7, in place of 27650.....
27876	—	Bobbin Winder (swinging automatic, right hand) complete, Nos. 27308 and 27875

**BOBBIN WINDER**  
(SWINGING AUTOMATIC, RIGHT HAND)  
FOR 2996, 19131 AND 24051  
FOR POWER TABLE

NO.	PLATE	NAME
225433	3469	Bobbin Winder and Tension Bracket Base
225453	3470	Frame with 202277 and 225438.....
225454	3471	" Hinge Pin.....
202277	3471	" Oil Packing (wick).....
225438	3471	" " Well Cap.....
225455	3471	" Spring.....
225456	3471	" " Plunger.....
202473	3470	Pulley with 200105c.....
200105c	—	" Set Screw.....
225381	3470	Spindle.....
225444	3471	Stop Latch.....
200056E	3471	" " Screw.....
225458	3471	" " Thumb Lever.....
225459	3471	" " " " Hinge Stud....
225460	3471	" " " " Joint Stud....
202478	3471	" " Trip Lever.....
200299H	3471	" " " " Hinge Screw....
225461	3471	Tension Bracket with 201499B.....
200082D	3471	" " Screw.....
228026	—	" " " Washer.....
2102	3471	" Disc.....
202407	3471	" Spring.....
201499B	3471	" Stud.....
201572B	3471	" " Thumb Nut.....
225462	—	Tension Bracket complete, Nos. 201572B, 202407, 225461 and two 2102.....
225382	3469	Bobbin Winder (swinging automatic, right hand) complete, Nos. 200056E, 200082D, 200299H, 202473, 202478, 225381, 225433, 225444, 225453 to 225456, 225458 to 225460, 225462, 228026 and two wood screws ¼ in. No. 13 R. H. B.....

**DRIVING ATTACHMENT**  
FOR 31-15, 31-16, 31-19, 31-27, 31-32, 31-34, 31-35  
AND 31-39 MACHINES

NO.	PLATE	NAME
16592	818	Balance Wheel (friction) with 7958, 16524 and two 435c.....
16524	—	Balance Wheel Friction Ring (leather)...



## DRIVING ATTACHMENT

NO.	PLATE	NAME
7958	5741	Balance Wheel Friction Ring Stop Pin...
24355	5757	" " Oil Cover.....
210D	5742	" " " " Screw.....
435c	5742	" " Set Screw.....
16514	768	Bobbin Winder Frame.....
32D	782	" " " Hinge Screw.....
16515	768	Bobbin Winder Frame complete, Nos. 333D, 5960, 5961, 5963, 15077 and 16514.....
5960	768	Bobbin Winder Friction Wheel (leather)...
5961	768	" " " " Washer
333D	782	" " " " " Screw.....
15072	2014	Bobbin Winder Position Pin.....
15077	773	" " Spindle with 15072.....
5963	768	" " " Flange.....
27306	1162	" " Spool Pin.....
27307	1162	" " " Stand.....
27308	1162	Bobbin Winder Spool Stand complete, Nos. 418E, 1562J, 2106, 10141, 11241, 27306, 27307 and two each 2455 and wood screws 1 in. No. 10.....
11241	2003	Bobbin Winder Spool Washer (cloth)....
12170	773	" " Spring.....
180F	782	" " " Screw.....
16516	774	" " Stop Latch with 152F and 1550H.....
152F	782	Bobbin Winder Stop Latch Adjusting Screw.....
1550H	783	Bobbin Winder Stop Latch Adjusting Screw Nut.....
75D	782	Bobbin Winder Stop Latch Hinge Screw
27303	773	" " " " Spring.....
2269	773	" " " " Stop Pin.....
2455	2014	" " Tension Disc.....
1562J	2014	" " " Regulating Thumb Nut.....
418E	2014	Bobbin Winder Tension Screw Stud.....
10141	2014	" " " Spring.....
2106	2014	" " " Thread Guard
16530	818	Bracket.....
692D	783	" Screw.....
12458	818	Drip Pan with four 1 in. wire nails, for Drop Feed Machine.....
20291	2049	Drip Pan with four 1 in. wire nails, for power table, for Wheel Feed Machines
16518	818	Driving Arm with 2269, 2928 and two 15132
2928	774	" " Brake (leather).....

## DRIVING ATTACHMENT

NO.	PLATE	NAME
15132	773	Driving Arm Brake Rivet.....
12178	774	" " Friction Plug (wood).....
427E	783	" " " " Adjusting Screw.....
1508c	783	Driving Arm Friction Plug Adjusting Screw Nut.....
693D	782	Driving Arm Hinge Screw.....
1579c	783	" " " " Nut.....
12475	818	" " Pitman.....
20371	768	" " " Crank.....
2022	773	" " " " Pin.....
20372	768	" " " " Spring.....
65D	782	" " " Hinge Screw.....
16522	—	Driving Arm complete, Nos. 32D, 75D, 180F, 427E, 693D, 1508c, 1579c, 12170, 12178, 16515, 16516, 16518, 16530 and 27303.....
16594	818	Driving Friction Pulley, 2 $\frac{5}{8}$ in. diam., with 861D and 10236.....
10236	774	Driving Friction Pulley Centre Bearing..
861D	5742	" " " Oil Hole Plug Screw.....
27072	—	Shaft Driving Pulley (sectional grooved) 12 in. diam., 1 $\frac{3}{8}$ in. bore with two 597c
597c	2011	Shaft Driving Pulley Clamping Screw....
12479	768	Starting Crank.....
2022	773	" " Pin.....
12477	768	" " Shaft.....
*44176	—	" " " 12477 with 12479, 20371 and two 2022.....
126036	8497	Treadle.....
126205	8629	" Bracket (left).....
126206	8629	Treadle Bracket (left) complete, Nos. 23258, 126205, 126207, 126208 and two wood screws 1 in. No. 14.....
126207	8629	Treadle Bracket (left) Hook.....
23258	8628	" " " Friction Washer.....
126208	8633	Treadle Bracket (left) Hook Rivet.....
46681	8497	" " (right).....
60502	—	" " " 46681 with two wood screws 1 in. No. 14.....
27637	818	Treadle Pitman Rod (lower).....
27638	5841	" " " " Spring.....
6055	5741	" " " " Washer
14081	818	" " " (upper).....

NO.	PLATE	NAME
9079	5844	Treadle Pitman Rod (upper) Clamp with 354c.....
	354c	774 Treadle Pitman Rod (upper) Clamp Screw
14233	818	Treadle Pitman complete, Nos. 2762, 6055, 14081, 27637, 27638 and two 9079.....
126209	—	Treadle complete, Nos. 60502, 126036 and 126206.....
126213	—	Treadle and Pitman complete, Nos. 14233 and 126209.....
	2762	1206 Treadle Stop Collar with 362F.....
	362F	2009 " " " Set Screw.....
12478	—	Driving Attachment with Bobbin Winder and Treadle complete, Nos. 210D, 692D, 12475, 16522, 16592, 16594, 20372, 24355, 27072, 27308, 44176, 126213 and two 65D.....

## DRIVING ATTACHMENT

FOR 31-20, 31-22 AND 31-24 MACHINES

This Driving Attachment is the same as 12478 with the following exceptions:

NO.	PLATE	NAME
19258	2009	Bobbin Winder Stop Latch with 152F and 1550H, in place of 16516.....
19260	—	Driving Arm complete, Nos. 32D, 75D, 180F, 427E, 693D, 1508C, 1579C, 12170, 12178, 16515, 16518, 16530, 19258 and 27303, in place of 16522.....
20141	—	Driving Attachment with Bobbin Winder and Treadle complete, Nos. 210D, 692D, 12475, 16592, 16594, 19260, 20372, 24355, 27072, 27308, 44176, 126213 and two 65D.....

## FOOT LIFTER PARTS

NO.	PLATE	NAME
5596	768	Bell Crank.....
56848	—	" " 5596 with 5599 and 5601.....
5599	768	" " Bracket.....
	178E	782 " " " Screw.....
5601	773	" " Hinge Pin.....
5735	1353	" " Spring.....
5598	768	Bell Crank complete, Nos. 5735 and 56848

NO.	PLATE	NAME
5670	—	Chain, length 26 in. to 35 in.....

NOTE: When ordering 5670, state length required.

4879	2004	Chain Connecting Link for 4885.....
12237	766	Lifting Lever with 448c, for 20008 and 20290.....
20340	2049	Lifting Lever with 448c, for 43928 and 43929.....
12415	768	Lifting Lever Connecting Rod for 20008, 43928 and 43929.....
20255	2020	Lifting Lever Connecting Rod for 20290
12416	774	" " " " Joint.....
	76D	782 " " " " " Hinge Screw.....
	1521E	772 Lifting Lever Connecting Rod Lock Nut
	802D	782 " " Hinge Screw.....
12241	772	" " Link for 20008, 20290 and 43929.....
21301	1353	Lifting Lever Link for 43928.....
	766D	782 " " " Hinge Screw.....
12240	772	" " Pin for 20008 and 20290...
16586	5843	" " " " 43929.....
19372	1313	" " " " 43928.....
	448C	783 " " " Set Screw.....
	2763	819 Rock Shaft.....
12242	819	Rock Shaft Hanger with two wood screws 1 in. No. 10.....
	6337	819 Rock Shaft Lifting Bracket with two 356c.
12243	819	" " " " Hook for 4880 and 5598.....
	7125	819 Rock Shaft Lifting Bracket Hook for 4880 and 5670.....
	356c	783 Rock Shaft Lifting Bracket Hook Set Screw
	356c	783 " " " " Set Screw.....
	2770	819 " " Stop Dog with 356c.....
	356c	783 " " " " Set Screw.....
4880	819	Rock Shaft complete, Nos. 2763, 2770, 7125, 12243 and two each 6337 and 12242...
4881	819	Treadle.....
4882	2004	" Shaft.....
4883	2004	" Spring.....
4884	819	" Stand.....
4885	819	Treadle complete, Nos. 4879, 4881 to 4884 and two wood screws 1 in. No. 16.....

## FOOT LIFTER PARTS

NO.	PLATE	NAME
20008	—	Foot Lifter complete for 31-15, 31-16, 31-20, 31-22, 31-27, 31-32 and 31-34 Machines, Nos. 76D, 766D, 802D, 1521E, 4880, 4885, 5598, 5670, 12237, 12240, 12241, 12415, 12416, and two 178E.....
20290	—	Foot Lifter complete for 31-24 Machine, Nos. 76D, 766D, 802D, 1521E, 4880, 4885, 5598, 5670, 12237, 12240, 12241, 12416, 20255 and two 178E.....
43928	—	Foot Lifter complete for 31-19 Machine, Nos. 76D, 766D, 802D, 1521E, 4880, 4885, 5598, 5670, 12415, 12416, 19372, 20340, 21301 and two 178E.....
43929	—	Foot Lifter complete for 31-35 Machine, Nos. 76D, 766D, 802D, 1521E, 4880, 4885, 5598, 5670, 12241, 12415, 12416, 16586, 20340 and two 178E.....

## KNEE LIFTER PARTS

NO.	PLATE	NAME
5596	768	Bell Crank.....
56848	—	“ “ 5596 with 5599 and 5601.....
5599	768	“ “ Bracket.....
178E	782	“ “ “ Screw.....
5601	773	“ “ Hinge Pin.....
5735	1353	“ “ Spring.....
5598	768	Bell Crank complete, Nos. 5735 and 56848
12237	766	Lifting Lever with 448c, for 12445, 20256, 20466 and 43933.....
20340	2049	Lifting Lever with 448c, for 20341, 43930, 43931 and 43934.....
12415	768	Lifting Lever Connecting Rod for 12445, 20341, 20466, 43930, 43931 and 43934..
20255	2020	Lifting Lever Connecting Rod for 20256 and 43933.....
12416	774	Lifting Lever Connecting Rod Joint.....
76D	782	“ “ “ “ “ Hinge Screw.....
1521E	772	Lifting Lever Connecting Rod Lock Nut.
802D	782	“ “ Hinge Screw.....
12241	772	“ “ Link for 12445, 20256, 20466, 43930, 43933 and 43934.....
21301	1353	Lifting Lever Link for 20341 and 43931..
766D	782	“ “ “ Hinge Screw.....
12240	772	“ “ Pin for 12445, 20256, 20466 and 43933.....

## KNEE LIFTER PARTS

NO.	PLATE	NAME
16586	5843	Lifting Lever Pin for 43930 and 43934...
19372	1313	“ “ “ “ 20341 and 43931...
448c	783	“ “ “ Set Screw.....
2763	766	Rock Shaft for 12250.....
20091	5735	“ “ “ 20465.....
7539	766	“ “ Hanger with two wood screws 1 in. No. 10, for 12250.....
2764	5735	Rock Shaft Hanger (back) with two wood screws 1 in. No. 10, for 20465.....
16128	5735	Rock Shaft Hanger (front) with two wood screws 1 in. No. 10, for 20465.....
2765	5735	Rock Shaft Knee Arm.....
2766	766	“ “ “ “ Hub with 356c, for 2768.....
20462	5735	Rock Shaft Knee Arm Hub with 356c, for 20463.....
356c	783	Rock Shaft Knee Arm Hub Set Screw...
2768	—	Rock Shaft Knee Arm complete for 12250, Nos. 2765 to 2767.....
20463	—	Rock Shaft Knee Arm complete for 20465, Nos. 2765, 2767 and 20462.....
2767	5735	Rock Shaft Knee Arm Plate with 356c..
356c	783	“ “ “ “ “ Set Screw..
20464	5735	“ “ Lifting Arm with 356c, for 20465.....
356c	783	Rock Shaft Lifting Arm Set Screw.....
6337	766	“ “ “ Bracket with two 356c, for 12250.....
2778	766	Rock Shaft Lifting Bracket Hook for 12250
356c	783	“ “ “ “ “ Set Screw
356c	783	“ “ “ “ “ Set Screw.....
2770	5735	“ “ Stop Dog with 356c.....
356c	783	“ “ “ “ “ Set Screw.....
12250	—	Rock Shaft complete for 12445, 20256, 20341 and 43930, Nos. 2763, 2768, 2778, 6337 and two each 2770 and 7539.....
20465	5735	Rock Shaft complete for 20466, 43931, 43933 and 43934, Nos. 2764, 16128, 20091, 20463, 20464 and two 2770
12445	—	Knee Lifter complete (power table or stand 25265) for 31-15, 31-16, 31-20, 31-22, 31-27, 31-32 and 31-34 Machines, Nos. 76D, 766D, 802D, 1521E, 5598, 12237, 12240, 12241, 12250, 12415, 12416 and two 178E.....

## KNEE LIFTER PARTS

NO.	PLATE	NAME
20341	—	Knee Lifter complete (power table or stand 25265) for 31-19 Machine, Nos. 76D, 766D, 802D, 1521E, 5598, 12250, 12415, 12416, 19372, 20340, 21301 and two 178E.
20256	—	Knee Lifter complete (power table or stand 25265) for 31-24 Machine, Nos. 76D, 766D, 802D, 1521E, 5598, 12237, 12240, 1224J, 12250, 12416, 20255 and two 178E.
43930	—	Knee Lifter complete (power table or stand 25265) for 31-35 Machine, Nos. 76D, 766D, 802D, 1521E, 5598, 12241, 12250, 12415, 12416, 16586, 20340 and two 178E.
20466	—	Knee Lifter complete (Stand 25255) for 31-15, 31-16, 31-20, 31-22, 31-27, 31-32 and 31-34 Machines, Nos. 76D, 766D, 802D, 1521E, 5598, 12237, 12240, 12241, 12415, 12416, 20465 and two 178E.
43931	—	Knee Lifter complete (Stands 25255 and 25265) for 31-19 Machine, Nos. 76D, 766D, 802D, 1521E, 5598, 12415, 12416, 19372, 20340, 20465, 21301 and two 178E.
43933	—	Knee Lifter complete (Stand 25255) for 31-24 Machine, Nos. 76D, 766D, 802D, 1521E, 5598, 12237, 12240, 12241, 12416, 20255, 20465 and two 178E.
43934	—	Knee Lifter complete (Stand 25255) for 31-35 Machine, Nos. 76D, 766D, 802D, 1521E, 5598, 12241, 12415, 12416, 16586, 20340, 20465 and two 178E.

## KNIFE GRINDER

FOR 5726

NO.	PLATE	NAME
27565	1104	Emery Wheel, 2 in. diam.
1508J	1105	" " Clamping Nut
27822	1105	" " " " Washer
27567	1105	" " Shaft
60934	—	Emery Wheel Shaft 27567 with 1508J, 27565 27569 and 27822.
27568	1105	Emery Wheel Shaft Oil Hole Cover (rubber)
27569	1105	Emery Wheel Shaft Pulley
310K	1105	" " " " Screw Centre
1516J	1105	" " " " " Nut
27564	1104	Frame with 27574.

## KNIFE GRINDER

NO.	PLATE	NAME
899J	1105	Knife Clamping Screw
126392	8632	" Holder
27657	—	" " Body for 27658
27679	—	" " " " 27681
27658	1105	Knife Holder complete for 5726, for 27661, Nos. 899J, 27657 and 27660.
27681	6255	Knife Holder complete, Nos. 899J, 11833, 27660 and 27679.
126393	—	Knife Holder complete, Nos. 227J, 899J, 27660, 126392 and 126394.
27323	1105	Knife Holder Guide Bar
27572	1104	" " " " Bracket with 27574.
310K	1105	Knife Holder Guide Bar Bracket Screw Centre
1516J	1105	Knife Holder Guide Bar Bracket Screw Centre Nut
27573	1105	Knife Holder Guide Bar Bracket Spring
27574	1105	" " " " " " " Hook
27659	1105	Knife Holder Stop Collar with 237K
237K	1105	" " " " Set Screw
27660	6255	" Position Pin for 27658 and 126393
27660	6255	" " " (lower) for 27681
11833	6255	" " " (upper) for 27681
261J	1105	" Regulating Thumb Screw
126394	8633	" Stop
227J	—	" " Screw
*60583	—	Knife Grinder, Nos. 261J, 27323, 27564, 27572, 27573, 27659, 60934, two 27568 and four each 310K and 1516J.
27661	—	Knife Grinder complete, Nos. 27662, 60583, either 27658, 27681 or 126393 and three wood screws 1 in. No. 10.
27662	1104	Wrench for 1508 and 1516.

## BENCH STAND

NO.	PLATE	NAME
79758	—	Bench Stand with 12248, two each 44244, wood screws 3/4 in. No. 10, three wood screws 1 1/2 in. No. 10 R. H. O. and A and four each 12405 and 28084.
12405	8633	Machine Cushion (felt) for 79758.
28084	8633	" " " Pin
27130	8633	" " (leather) for 12248.

NO.	PLATE	NAME
44243	8633	Machine Hinge Connection.....
2809	8633	" " " Hinge Pin....
33887	8633	" " Plate.....
44244	----	Machine Hinge complete, Nos. 2809, 33887, 44243 and Merlized wood screw 1¼ in. No. 14.....
12248	8632	Machine Rest with 27130 and two wood screws 1 in. No. 12.....

## STAND

### HIGH SPEED

NO.	PLATE	NAME
25329	3813	Band Wheel, 16 in. diam., with 1312c....
1312c	3817	" " Set Screw.....
25421	3814	" " Shaft.....
25422	3815	" " " Driver (left).....
25423	3815	" " " " Clutch (left).....
25424	3815	Band Wheel Shaft Driver (left) Clutch (right) with 5564.....
25425	3817	Band Wheel Shaft Driver (left) Clutch Spring.....
5564	3817	Band Wheel Shaft Driver (left) Clutch Spring Hook.....
25426	3815	Band Wheel Shaft Driver (right).....
25427	3815	" " " " Clutch (left).....
25428	3815	Band Wheel Shaft Driver (right) Clutch (right) with 5564.....
25425	3817	Band Wheel Shaft Driver (right) Clutch Spring.....
5564	3817	Band Wheel Shaft Driver (right) Clutch Spring Hook.....
25429	3815	Band Wheel Shaft Driving Flange with 356c.....
356c	3817	Band Wheel Shaft Driving Flange Set Screw.....
*46604	----	Band Wheel Shaft Driving Flange (left) complete, Nos. 25422 to 25425, 25429 and 25434.....
*46605	----	Band Wheel Shaft Driving Flange (right) complete, Nos. 25425 to 25429 and 25434
25370	----	Belt, size ¼ in., length 67½ in., with 25127
25127	3817	" Hook.....

NO.	PLATE	NAME
25430	3814	Brace.....
748R	3817	" Screw.....
20467	5762	Drip Pan with eight 1 in. wire nails.....
25431	3813	Driving Arm (left) with 435c and 25435...
25432	3813	" " (right) with 435c and 25435
25433	3816	" " Hinge Pin.....
435c	3817	" " " " Set Screw.....
25434	3815	" Pinion.....
25435	3816	" Segment (rack).....
534R	3817	" Bolt with 1510R.....
1510R	3817	" " " Nut.....
25446	3817	" " " " Washer.....
25349	3813	Foot Rest.....
25350	3817	" " Cotter Pin.....
25435	3816	" " Hinge Pin.....
25436	3813	Leg (left).....
25437	3813	" (right).....
25438	3814	" Stay Rod.....
1508R	3817	" " " Nut.....
25086	3813	Wrench for 1510.....
25255	----	Stand (iron work) complete, Nos. 25086, 25329, 25421, 25430 to 25432, 25436 to 25438, 46604, 46605, two each 25345, 25349, 25350, 25433 and four each 534R, 748R, 1508R and 25446.....

## STAND

### ROCKING TREADLE, BALL BEARING PITMAN

NO.	PLATE	NAME
25301	3825	Band Wheel, 16 in. diam., with 972c....
46519	3825	" " Crank.....
46520	----	Band Wheel Crank and Pitman (ball bear- ing) complete, Nos. 1520R, 25371, 46506 to 46509, 46519, 46523, 46630, 46655 and six 25362.....
297c	3826	Band Wheel Crank Screw Centre.....
46629	----	" " " " " 2 9 7 c with 1507R.....
1507R	3826	Band Wheel Crank Screw Centre Nut...
972c	3826	" " Set Screw.....
25016	----	Belt, size ¼ in., length 69½ in. with 25127
25127	3817	" Hook.....
46667	----	Brace.....
82985	5216	" 46667 with three 46629.....
748R	3817	" Screw.....

NO.	PLATE	NAME
46528	6142	Brace Section (left) with 46629.....
46663	6142	" " (right) with two 46629....
880R	5843	" " Screw.....
46662	6142	Brace (sectional) complete, Nos. 46528, 46663 and three 880R.....
82973	5216	Leg.....
25362	3826	Pitman Ball, size $\frac{1}{8}$ in.....
46506	3826	" " Bearing Adjusting S c r e w Ring.....
46507	3826	Pitman Ball Bearing Adjusting Screw Ring Locking Washer (brass).....
46508	3826	Pitman Ball Bearing Ring.....
46509	3826	" " Case.....
46655	3826	" " Separator.....
46523	3825	" Rod with 25360.....
*25360	—	" " Ball.....
25371	3826	" " " Bushing.....
25361	3826	" " " Screw Bearing.....
46630	—	" " " " " 2 5 3 6 1 with 1670R.....
1670R	3826	Pitman Rod Ball Screw Bearing Nut....
1520R	3826	" " Lock Nut.....
46524	3825	Treadle.....
297c	3826	" Screw Centre.....
46629	—	" " " 297c with 1507R... Nut.....
1507R	3826	" " " Nut.....
25086	3813	Wrench for 1507 and 1670.....
25200	3825	" " 972.....
25265	—	Stand (iron work) complete, Nos. 25086, 25200, 25301, 46520, 46524, 82985, two 82973 and four 748R.....

## STAND

### FOR ELECTRIC MOTOR

NO.	PLATE	NAME
297c	3826	Band Wheel Crank Screw Centre.....
46629	—	" " " " " 2 9 7 c with 1507R.....
1507R	3826	Band Wheel Crank Screw Centre Nut... 25490 — Belt, size $\frac{1}{4}$ in., length 36 in., with 25127. 25127 3817 " Hook..... 46667 — Brace..... 82985 5216 " 46667 with three 46629..... 748R 3817 " Screw..... 46528 6142 " Section (left) with 46629.....

NO.	PLATE	NAME
46663	6142	Brace Section (right) with two 46629....
880R	5843	" " Screw.....
46662	6142	Brace (sectional) complete, Nos. 46528, 46663 and three 880R.....
82973	5216	Leg.....
25082	5760	Treadle.....
297c	3826	" Screw Centre.....
46629	—	" " " 297c with 1507R... 1507R 3826 " " " Nut.....
7958	5741	Motor Pitman Pin.....
25086	3825	Wrench for 1507.....
25279	—	Stand (iron work) complete, Nos. 7958, 25082, 25086, 82985, two 82973 and four 748R.....

## STAND

### ROCKING TREADLE, BALL BEARING PITMAN, FOR FOOT POWER AND S. D. 11 OR S. A. 12 ELECTRIC MOTORS

NO.	PLATE	NAME
25301	3825	Band Wheel, 16 in. diam., with 972c....
46519	3825	" " Crank.....
46656	—	Band Wheel Crank and Pitman (ball bear- ing) complete, Nos. 1520R, 25371, 46506 to 46509, 46519, 46630, 46655, 46658 to 46660 and six 25362.....
297c	3826	Band Wheel Crank Screw Centre.....
46629	—	" " " " " 2 9 7 c with 1507R.....
1507R	3826	Band Wheel Crank Screw Centre Nut... 972c 3826 " " Set Screw.....
25016	—	Belt, size $\frac{1}{4}$ in., length 69 $\frac{1}{2}$ in., with 25127, from band wheel to machine.....
46657	—	Belt, size $\frac{1}{4}$ in., length 36 $\frac{1}{2}$ in., with 25127, from motor to machine.....
25127	3826	Belt Hook.....
46667	—	Brace.....
82985	5216	" 46667 with three 46629.....
748R	3826	" Screw.....
46662	6142	Brace (sectional) complete, Nos. 46528, 46663 and three 880R.....
46528	6142	Brace Section (left) with 46629.....
46663	6142	" " (right) with two 46629....
880R	5843	" " Screw.....
82973	5216	Leg.....
25382	3826	Pitman Ball, size $\frac{1}{8}$ in.....



NO.	PLATE	NAME
225396	7233	Thread Unwinder complete, Nos. 201696j, 202490, 225388, 225392, 225395, two 225391 and three wood screws 7/8 in. No. 12.....
27739	8520	Thread Cone (wood) for large cones.....
225390	8520	" " Holder, for inverted cones.

NOTE: Nos. 27739 and 225390 are used with, but not included in, 225396

**THREAD UNWINDER**

**FOR ONE LARGE SPOOL OR ONE LARGE CONE OF THREAD  
OBSOLETE, USE 225394**

NO.	PLATE	NAME
27623	2836	Spool Pin.....
155c	5753	" " Set Screw.....
41526	2836	" Rest.....
60701	—	" " 41526 with 155c and 1149c..
41527	—	" " 60701 with 27623.....
1149c	5742	" " Set Screw.....
27940	2836	" Stand with 453c.....
41514	2836	" Weight, 4 in. diam., with 41515....
41515	5742	" " Centre Pin.....
27739	2836	Thread Cone (wood).....
41630	2836	" Guard with 208E and 41569.....
41569	5842	" " Eyelet.....
41637	2836	" " Rod (lower).....
41638	2836	" " (upper).....
41639	2836	" " " Coupling with two 456c.....
456c	773	Thread Guard Rod Coupling Set Screw..
41640	—	Thread Guard Rod complete, 30 in. long, Nos. 41637 to 41639.....
453c	783	Thread Guard Rod Set Screw.....
208E	782	" " Screw.....
41529	2836	Thread Unwinder complete, Nos. 27739, 27940, 41514, 41527, 41630, 41640 and three wood screws 1 in. No. 12.....

**THREAD UNWINDER**

**FOR TWO LARGE SPOOLS OR TWO LARGE CONES OF THREAD  
OBSOLETE, USE 225396**

This Thread Unwinder is the same as No. 41529 with the following exceptions:

NO.	PLATE	NAME
41530	2837	Spool Rest, in place of 41526.....

NO.	PLATE	NAME
60455	—	Spool Rest 41530 with 1149c and two 155c in place of 60701.....
41531	—	Spool Rest 60455 with two 27623, in place of 41527.....
41631	2837	Thread Guard with 208E and two 41569, in place of 41630.....
41533	2837	Thread Unwinder complete, Nos. 27940, 41531, 41631, 41640, two each 27739, 41514 and three wood screws 1 in. No. 12

**OBSOLETE PARTS**

NO.	PLATE	NAME
*20399	—	Arm with 11104, for 31-37 Machine.....
29599	2014	" Oil Tube Packing (felt) for 11119, 12454 and 24131.....
25330	3816	Band Wheel Brake (rubber) for 25418...
25418	3814	" " " Lever with 443c and 25330, for 25255.....
25419	3816	Band Wheel Brake Lever Hinge Pin for 25418.....
443c	3817	Band Wheel Brake Lever Hinge Pin Set Screw.....
25420	3816	Band Wheel Brake Lever Spring for 25418
28366	2645	Binder Folder for 28794, use 120493, 120494 or 120495.....
12484	2003	Bobbin Winder Spring for 12172, 12202 and 12337.....
12365	2001	Crank Connecting Rod with 14013 and two 896E, for 375.....
12496	2001	Crank Connecting Rod with 14013 and two 896E, for 908, use 20197.....
*14013	—	Crank Connecting Rod Cap for 12365 and 12496.....
375c	782	Crank Connecting Rod Hinge Screw....
1518j	783	" " " " " Nut for 375.....
20021	5761	Drip Pan with four 1 in. wire nails, for power table, for Drop Feed Machines, use 44212.....
12225	768	Driving Arm Pitman Crank for 12476, for 12478 and 20141.....
12476	774	Driving Arm Pitman Crank Spring for 12225, for 12478 and 20141.....
27636	363	Driving Attachment Treadle for 27642...
9082	773	" " " Bearing Cotter Pin for 27642.....



NO.	PLATE	NAME
2877	818	Driving Attachment Treadle Pitman Rod (upper) for 15130.....
15130	818	Driving Attachment Treadle Pitman complete for 15131, Nos. 2762, 2877, 6055, 9079, 27637 and 27638.....
2878	363	Driving Attachment Treadle Stand for 27642.....
27642	—	Driving Attachment Treadle complete for 14234 and 15131, Nos. 2878, 9082, 27636 and four wood screws 1 in. No. 16
15131	—	Driving Attachment Treadle and Pitman complete for 12478 and 20141, Nos. 15130 and 27642, use 126042.....
14234	—	Driving Attachment Treadle and Pitman complete for 12478 and 20141, Nos. 14233 and 27642.....
20402	5756	Edge Guide for 31-37 Machine.....
12371	779	Feed Dog, for shirt work, for 31-15 Machine.....
20009	1258	Feed Dog, for tailor work, for 31-15, 31-20 and 31-22 Machines.....
20329	776	Feed Dog for 31-32 Machine.....
12369	776	Feed Dog, for cloth, 12 teeth (12 teeth to the inch) for 31-15, 31-19, 31-20 and 31-22 Machines.....
12457	2699	Feed Dog, for cloth, 16 teeth (16 teeth to the inch) for 31-15, 31-19, 31-20 and 31-22 Machines.....
20303	776	Feed Dog (reversible) for 31-32 Machine
12428	767	Feed and Feed Lifting Eccentric with 446c, for 31-15, 31-16, 31-20, 31-22 and 31-24 Machines.....
12429	2002	Feed Forked Connection for 31-15, 31-16, 31-20, 31-22 and 31-24 Machines.....
12331	5757	Feed Forked Connection for 31-32 Machine, use 44003.....
12374	766	Feed Lifting Rock Shaft for 12375.....
12375	—	Feed Lifting Rock Shaft complete for 31-15, 31-16, 31-19, 31-20, 31-22, 31-24, 31-27, 31-32, 31-34, 31-35 and 31-37 Machines, Nos. 3043, 12374 and 12376, use 44126.....
12200	774	Feed Lifting Rock Shaft Crank (back) with 462c, use 3043.....
3043	770	Feed Lifting Rock Shaft Crank (back) with 462c, for 12375.....

NO.	PLATE	NAME
2049	773	Feed Lifting Rock Shaft Crank (back) Pin
462c	773	“ “ “ “ “ “ Set
		Screw.....
12430	2002	Feed Lifting Rock Shaft Crank Connecting Rod with 12204 and two 966E, for 31-15, 31-16, 31-19, 31-20, 31-22, 31-24, 31-27, 31-32, 31-34, 31-35 and 31-37 Machines
*12204	—	Feed Lifting Rock Shaft Crank Connecting Rod Cap for 12430.....
58E	782	Feed Regulator Hinge Screw.....
12380	—	Feed Rock, Shaft complete, Nos. 3043 and 12379, use 20333.....
20239	—	Feed Rock Shaft complete for 31-24 Machine, Nos. 3043, 20238 and 20247, use 20334.....
28969	2669	Guide (adjustable, hinged) complete, Nos. 2860, 940b, 7071, 28971 to 28973 and 35610, use 120428.....
27680	—	Knife Grinder Knife Holder Body for 27682.....
27682	6255	Knife Grinder Knife Holder complete for 27661, Nos. 899i, 11833, 27660 and 27680, use 126393.....
46522	3825	Leg for 25265, 25279 and 25284.....
19363	1312	Lifting Presser Bar Guide Bracket with 453c, for 31-19 Machine.....
20367	770	Needle Bar Connecting Stud Slide Block for 20368.....
20368	770	Needle Bar Connecting Stud complete, Nos. 453c, 12383 and 20367, use 12384
12385	767	Needle Bar Crank with 855c, and 858c, use 20188.....
855c	783	Needle Bar Crank Position Screw for 12385
696E	782	“ “ Plug Screw.....
12495	2014	“ “ “ “ Rivet.....
1072F	1317	“ Set Screw for 16568.....
36578	—	Oiler (copper plated) with 36579 (Attachments and Accessories) use 120342.....
36579	—	Oiler Spout, 3½ in. long, with 120117, for 36578.....
120117	—	Oiler Spout Washer (leather) for 36579...
12188	768	Oil Cover for 12478 and 20141.....
397D	782	“ “ Screw.....
24020	2009	“ Cup for 24024.....
44004	2565	“ “ “ 44007.....
24023	2009	“ “ Extension with 24075, for 24024
12486	—	“ “ Packing (felt) for 24024.....

## OBSOLETE PARTS

NO.	PLATE	NAME
24024	2009	Oil Cup complete for 31-16 Machine, Nos. 12486, 24020 and 24023, use 44007.....
44007	2565	Oil Cup complete for 31-16 Machine, Nos. 44004 to 44006, use 44225.....
12386	767	Oscillating Rock Shaft for 375, for 12387.
12497	2001	“ “ “ “ 908 and 1902, for 12498, use 24104.....
12387	—	Oscillating Rock Shaft complete, Nos. 4784, 12386 and 12388.....
12498	—	Oscillating Rock Shaft complete, Nos. 4784, 12388 and 12497, use 24105.....
878r	783	Oscillating Rock Shaft Hinge Pin Oil Hole Stop Screw.....
12459	773	Oscillating Rock Shaft Hinge Pin Oil Hole Stop Screw Washer (leather).....
12443	772	Oscillating Rock Shaft Oil Pad for 16508.
16508	772	“ “ “ “ H o l d e r with 12443.....
238d	782	Oscillating Rock Shaft Oil P a d H o l d e r Screw.....
1902	783	Oscillating Shaft Crank Roller and Screw Stud.....
1518r	783	Oscillating Shaft Crank Roller and Screw Stud Nut.....
460c	783	Oscillating Shaft Crank Set Screw for 19447
229d	782	Oscillating Shaft Crank Slide Block Cap Screw for 19449, use 226d.....
12390	771	Oscillating Shaft Crank complete, Nos. 457c, 1518r, 1902 and 19496.....
20407	5756	Plaiting Blade Holder (lower) Hinge Stud for 20438.....
20409	5756	Plaiting Blade Holder (lower) Spring Stop for 20438.....
20431	5757	Plaiting Gear Cover for 31-37 Machine...
206d	5756	“ “ “ Screw.....
20438	5756	“ Rock Shaft for 20409, for 31-37 Machine.....
43805	5742	Presser Foot for 31-42 Machine.....
2532	772	“ “ Hinge Pin for 20157, 20311, 20346 and 24489.....
2532	1371	Presser Foot (right) Hinge Pin for 28814
24545	—	“ “ Shank for 24546.....
24546	780	Presser Foot (spring hinged) complete for 12425, 12481, 19474 and 20119, Nos. 24544, 24545, 26231 and 62527.....
25991	2029	Quilter Guide for 25990.....

## OBSOLETE PARTS

NO.	PLATE	NAME
25990	2029	Quilter complete, Nos. 25991 and 25992, use 120485.....
24117	2006	Shuttle Bobbin Case Guide Plate for 24120.....
1053d	2006	Shuttle Bobbin Case Guide Plate Screw for 24120.....
15003	771	Shuttle Bobbin Case Hinge, Nos. 2972 to 2974 for 12417 and 19293.....
20592	—	Shuttle Bobbin Case Hinge, Nos. 2974, 20593 and 20594, for 20591, use 20652
20652	—	Shuttle Bobbin Case Hinge, Nos. 2973, 2974 and 20593 for 20653.....
2972	771	Shuttle Bobbin Case Latch for 15003.....
20593	2012	“ “ “ “ “ 20592 and 20652.....
20594	2012	Shuttle Bobbin Case Latch Lever for 20592.....
2521	1371	Shuttle Bobbin Case Latch Spring for 20591 and 20653.....
20595	2012	Shuttle Bobbin Case Position Finger for 20591, 20651 and 20653.....
12417	—	Shuttle Bobbin Case complete for 12392, Nos. 591r, 592e, 2523, 2526, 2975, 7553 and 15003, use 19293.....
19293	771	Shuttle Bobbin Case complete for 19292, Nos. 591r, 592e, 2523, 2975, 7553, 15003 and 15098, use 24074.....
20591	2012	Shuttle Bobbin Case complete for 20590, Nos. 591r, 592e, 2521, 2523, 20592, 20595 and 20600, use 20653.....
20653	2012	Shuttle Bobbin Case complete for 20655, Nos. 591r, 592e, 2521, 2523, 20595, 20652 and 20654, use 20651.....
20651	2012	Shuttle Bobbin Case complete for 20655, Nos. 591r, 592e, 2523, 2975, 20595, 20650 and 20654.....
24074	2013	Shuttle Bobbin Case complete for 12487 and 19292, Nos. 591r, 592e, 2523, 2975, 7553, 15098 and 15141, use 62740.....
20596	2012	Shuttle Body for 20590 and 20655.....
462c	773	“ Driver Set Screw for 12444 and 19406.....
12392	—	Shuttle, 1 $\frac{1}{8}$ in. diam., Nos. 2996, 12393 and 12417, use 19292.....
20590	—	Shuttle, 1 $\frac{1}{8}$ in. diam., Nos. 19131, 20591, and 20596, for 31-20 Machine, use 20655

NO.	PLATE	NAME
20655	2012	Shuttle, 1½ in. diam., Nos. 19131, 20596 and 20651, for 31-20, 31-22 and 31-24 Machines.....
5708	—	Shuttle Race Body for 5707.....
12490	—	“ “ “ “ 12489.....
19402	—	“ “ “ “ 19404.....
24008	—	“ “ “ “ 62623.....
62623	—	“ “ “ “ 24008 with 24009 and two 1053D, for 24010.....
24118	—	Shuttle Race Body for 24120.....
5709	767	“ “ Cap for 5707.....
12491	2005	“ “ “ “ 12489.....
19403	2006	“ “ “ “ 19404.....
662D	782	“ “ “ Screw for 5707, 12489 and 19404.....
4621	5843	Shuttle Race Cap Steady Pin for 19404..
5707	767	Shuttle Race complete for 31-15 and 31-16 Machines, Nos. 648D, 2531, 2533, 5708, 5709 and two each 662D and 2532.....
12489	—	Shuttle Race (sectional) complete for 31-16 Machine, Nos. 648D, 2531, 2533, 12490 to 12494 and two each 85D, 662D and 2532, use 20005.....
19404	1356	Shuttle Race complete for 31-20 Machine, Nos. 648D, 662D, 2419, 2533, 4621, 19402, 19403 and two 2532, use 24325
24010	1357	Shuttle Race complete for 31-20 Machine, Nos. 648D, 2419, 2533, 62623 and two 2532, use 24325.....
24120	2006	Shuttle Race complete for 31-20, 31-22 and 31-24 Machines, Nos. 907D, 2419, 2533, 24009, 24117, 24118, two 2532 and four 1053D, use 24325.....
647F	774	Shuttle Race Screw, use 145D.....
12395	—	“ “ Slide, use 12431.....
240D	782	“ “ Spring Screw for 12396 and 20450.....
12396	—	Shuttle Race Slide complete, Nos. 4307, 12395 and two 240D, use 12432.....
2526	5842	Shuttle Tension Spring for 12417, use 15098.....
15098	771	Shuttle Tension Spring for 19293 and 24074.....
20600	2012	Shuttle Tension Spring for 20591.....
43806	—	Stop Wheel with 2269, for 43807.....
12325	5738	“ “ Block for 43807.....

NO.	PLATE	NAME
43807	5735	Stop Wheel complete for 31-42 Machine, Nos. 446C, 12316, 12325, 12345, 43806 and two 840D, use 43943.....
2921	772	Tension Disc for 44147.....
20037	2009	“ Releaser for 44147.....
20185	2011	“ “ “ 20370.....
20314	1353	“ “ “ 29549.....
12354	772	“ “ use 20037.....
12397	772	Tension Releasing Lever for 31-19 and 31-42 Machines.....
20186	2011	Tension Releasing Lever for 31-22 Machine.....
20370	2048	Tension Releasing Lever for 20185, for 31-22 Machine.....
29549	1353	Tension Releasing Lever for 31-15, 31-16, 31-20, 31-24, 31-27, 31-32, 31-34 and 31-37 Machines.....
413C	783	Tension Screw Stud for 33892.....
33892	—	“ “ “ 413C with 1560C, for 44174 and 44149, Nos. 20061 to 20063, for 31-15, 31-16, 31-20, 31-22, 31-24, 31-27, 31-32, 31-34 and 31-37 Machines
20061	1353	Tension Screw Stud Bushing.....
20062	1353	“ “ “ Flange.....
20063	1353	“ “ “ Collar.....
20064	2014	“ Thread Guard.....
190D	782	“ “ “ Screw.....
44147	—	Tension complete for 31-19 and 31-42 Machines, Nos. 2923, 7336, 8511, 20037, 33892 and two 2921.....
44149	—	Tension complete for 31-39 Machine, Nos. 2923, 7336, 8511, 33892 and two 2102..
Nos. 12400 To 12402 For 12399		
460C	783	Thread Retainer Set Screw.....
12400	773	“ “ Sleeve.....
12401	773	“ “ Spring.....
12402	773	“ “ Stud.....
460C	783	“ “ “ Set Screw for 12402
12399	—	Thread Retainer complete for 31-15, 31-16 31-19, 31-20, 31-22, 31-24, 31-27, 31-32, 31-34, 31-35, 31-37 and 31-39 Machines, Nos. 12400 to 12402, use 52379.....
430C	783	Thread Take-up Lever Link Hinge Pin Set Screw for 31-15, 31-16, 31-19, 31-20, 31-22, 31-24, 31-27, 31-32, 31-34, 31-35, 31-37 and 31-39 Machines.....

NO.	PLATE	NAME
8511	773	Thread Take-up Spring for 44147 and 44149
12413	779	Throat Plate, large needle hole, for 12371
12441	—	“ “ small needle hole, for 12371
20010	1258	“ “ large needle hole, for 20009, use 44137. ....
20024	—	Throat Plate, small needle hole, for 20009, use 44138. ....
12438	776	Throat Plate, large oblong needle hole, for 20329. ....
20192	—	Throat Plate, small oblong needle hole, for 20329. ....
12411	776	Throat Plate, large needle hole, for 12369, 12457 and 20303. ....
12449	—	Throat Plate, small needle hole, for 12369, 12457 and 20303. ....

**SINGER** Needles should be used  
in **SINGER** Machines  
These Needles and their Containers  
are marked with the  
Company's Trade Mark "SIMANCO.\*\*" 1

Needles in Containers marked  
"FOR SINGER MACHINES"  
are NOT **SINGER** made needles. 2

## NUMERICAL LIST OF PARTS

NO.	PLATE	NAME
16c	5740	Starting Bell Crank Hinge Screw for 12344
32D	782	Bobbin Winder Frame Hinge Screw for 12172, 12202, 12337, 16522, 19260, 20309 and 20498. ....
32F	5753	Plaiting Rock Shaft Lever Hinge Screw (intermediate) for 31-37 Machine. ....
35D	2011	Bobbin Winder Stop Latch Hinge Screw for 27647, 27650, 27651 and 27875. ....
58E	782	Feed Regulator Hinge Screw, obsolete. ...
58D	782	Tucker Tuck Guide Plate Arm Hinge Screw for 26683. ....
65D	782	Driving Attachment Driving Arm Pitman Hinge Screw for 12478 and 20141. ....
66F	5753	Plaiting Rock Shaft Lever Hinge Screw (back) for 31-37 Machine. ....
66F	5753	Plaiting Rock Shaft Lever Hinge Screw (front) for 31-37 Machine. ....
69D	5742	Ruffler Driving Lever Hinge Screw for 26018 and 26230. ....
75D	782	Bobbin Winder Stop Latch Hinge Screw for 16522 and 19260. ....
76D	782	Lifting Lever Connecting Rod Joint Hinge Screw (Foot and Kneec Lifters) for 12445, 20008, 20256, 20290, 20341, 20466, 43928, 43929, 43930, 43931, 43933 and 43934. ....
76D	2061	Separating Blade Arm Hinge Screw for 35280. ....
85D	2005	Shuttle Race Ring Clamp Screw for 12489 and 20005. ....
93F	2669	Presser Foot Tension Plate Screw for 35447. ....
94D	1375	Edge Guide Slide Lever Hinge Screw for 26810. ....
94D	1376	Hemmer Folder Disengaging Lever Hinge Screw for 28688. ....
96D	2038	Strip Folder Hinge Screw for 28707. ....
102D	2035	Ruffler Ruffling Blade Lever Disengaging Lever Hinge Screw for 26724. ....
102D	2061	Separating Blade Arm Latch Lever Hinge Screw for 35280. ....
102D	2061	Separating Blade Holder Hinge Screw for 35280. ....

NO. PLATE	NAME
108D 2061	Separating Blade Holder Spring Screw for 35280.....
129D 5736	Finger Protector Screw for 31-39 Machine
131D 2019	Presser Foot Roller Screw for 20243.....
134D 2019	Reciprocating Spring Presser Shaft Bracket (back) Screw for 31-24 Machine.....
135D 2026	Corder Screw for 26169, 26328 and 28788
141D 5750	Plaiting Cam Shaft Bracket Screw for 31-37 Machine.....
141D 5750	Plaiting Lever Bracket Screw for 31-37 Machine.....
144D 782	Arm Shaft Screw for 31-15, 31-16, 31-19, 31-20, 31-22, 31-24, 31-27, 31-32, 31-34, 31-35, 31-37 and 31-39 Machines.....
145D 5752	Plaiting Gear Cover Screw for 31-37 Machine.....
145D 1324	Ruffling Arm Shaft Bracket (right) Screw for 31-27 Machine.....
145D 5752	Separating Blade Bracket Screw for 31-37 Machine.....
145D 782	Shuttle Race Screw.....
152F 2038	Binder Guide (upper) Screw for 26694....
152F 782	" Screw for 25664.....
152F 782	Bobbin Winder Stop Latch Adjusting Screw for 16516 and 19258.....
155c 5739	Needle Bar Connecting Stud Set Screw for 12131.....
155c 5753	Plaiting Rock Shaft Lever Arm Hinge Stud Set Screw for 20423.....
155c 5753	Thread Unwinder Spool Pin Set Screw for 60455 and 60701.....
157J 782	Feed Lifting Rock Shaft Crank Clamping Screw for 12376.....
157J 782	Feed Rock Shaft Crank Clamping Screw for 29633.....
158c 1206	Bed Frame Cushion Screw for 20067.....
159D 1324	Ruffling Arm Shaft Bracket (left) Screw for 31-27 Machine.....
162D 8628	Belt Guard Extension Screw for 126365..
175D 5736	Lifting Presser Bar Guide Bracket Support Screw for 31-19 Machine.....
176D 2038	Presser Foot Screw for 31-37 Machine....
176D 2038	Tucker Screw for 26377.....
178E 782	Bell Crank Bracket Screw (Foot and Knee Lifters) for 12445, 20008, 20256, 20290, 20341, 20466, 43928, 43929, 43930, 43931, 43933 and 43934.....

NO. PLATE	NAME
178F 5750	Plaiting Gear (back) Set Screw for 20425
180F 782	Bobbin Winder Spring Screw for 12172, 12202, 12337, 16522, 19260, 20309 and 20498.....
181D 1323	Ruffling Regulator Stop Screw for 31-27 Machine.....
185H 1371	Presser Foot (left) Screw for 28816.....
185H 5754	Separating Blade Holder Screw for 31-37 Machine.....
190D 782	Binder Screw for 25650, 25653, 25656 and 36463.....
190D 782	Binder Ribbon Tension Screw for 26250, 26402, 26466, 28657, 28784, 120127, 120437 and 120459.....
190D 782	Box Plaiter Centre Guide Holder Screw for 28352.....
190D 2026	Corder Arm Adjusting Screw for 25792...
190D 1377	" Cord Guide Screw for 120207....
190D 1375	Edge Guide Screw for 26810.....
190D 782	Face Plate Screw for 31-15, 31-16, 31-20, 31-22, 31-24, 31-27, 31-32, 31-34, 31-37, 31-39 and 31-42 Machines.....
190D 1376	Hemmer Screw for 28688.....
190D 782	Presser Foot Screw for 31-15, 31-16, 31-20, 31-22, 31-24, 31-27, 31-32, 31-34, 31-35 and 31-42 Machines.....
190D 782	Reciprocating Spring Presser Regulator Crank Clamping Screw for 20247.....
190D 782	Reciprocating Spring Presser Shaft Bracket (front) Screw for 31-24 Machine.....
190D 782	Ruffling Arm Clamping Screw for 26889..
190D 1371	Ruffler Starting Lever Clamping Screw for 28601.....
190D 782	Starting Bell Crank Roller Screw for 1885
190D 782	Strip Folder Holder and Guide Screw for 35351.....
190D 782	Tension Thread Guard Screw, obsolete...
190D 782	Welt Guide Screw for 26150.....
191c 1366	Knife Bar Crank Set Screw for 24431....
191F 2019	Reciprocating Spring Presser Shaft Crank (back) Set Screw for 20254.....
193F 1379	Binder Folder Screw for 26953, 28678 and 28776.....
193D 1312	Lifting Presser Foot Screw for 31-19 Machine.....
196J 5809	Finger Guard Holder Clamping Screw for 36820.....

NO. PLATE	NAME
196F 2038	Tucker Tuck Marking Bar Pressure Spring Clamp Set Screw for 26109.....
198D 2658	Presser Foot Knife Clamp Screw for 28967
198D 1371	" " (right) Shank Cap Screw for 28816.....
199D 1312	Lifting Presser Bar Bell Crank Cap Screw for 24716.....
199D 1312	Lifting Presser Bar Bell Crank Connecting Link Cap Screw for 24716.....
199D 5752	Plaiting Lever Connecting Rod Cap Screw for 31-37 Machine.....
199D 1312	Vibrating Presser Bar Cap Screw for 19366
200F 2633	Box Plaiter Sliding Bracket Arm Extension Bracket Screw for 28352.....
200F 5752	Plaiting Rock Shaft Crank Set Screw for 20439.....
206D 5756	Plaiting Gear Cover Screw for 31-37 Machine, obsolete.....
207F 2021	Binder Folder Screw for 26250, 26402, 26466, 28657, 28784, 28794, 28861, 120437, 120459 and 120467.....
207F 2021	Binder Guide (upper) Screw for 25664..
207F 2645	" Screw for 28828.....
207F 2645	" Strip Guide Screw for 28861.....
207F 1375	Edge Guide Slide Cap (left) Screw for 26810.....
207F 1375	Edge Guide Slide Cap (right) Screw (large) for 26810.....
207F 1376	Hemmer Slide Cap Screw (back) for 28688.....
207F 2021	Quilter Guide Holder Set Screw for 25992
207F 2021	" " Set Screw for 25992.....
207F 2021	Ruffler Foot Screw for 26018.....
207F 2021	" Frame Stud Set Screw for 26230
207F 1344	Ruffling Arm Adjusting Screw for 26890..
208E 782	Feed Dog Screw for 31-15, 31-16, 31-19, 31-20, 31-22, 31-24, 31-27, 31-32, 31-34, 31-35 and 31-37 Machines.....
208D 5745	Plaiting Blade (lower) Screw for 31-37 Machine.....
208D 5745	Plaiting Blade (upper) Screw (right) for 31-37 Machine.....
208E 782	Thread Unwinder Thread Guard Screw for 41630 and 41631.....
208E 782	Thread Unwinder Thread Guide Rod Screw for 41630, 41631 and 225392....
209C 8628	Quilter Guide Set Screw for 120482.....

NO. PLATE	NAME
210D 5742	Driving Attachment Balance Wheel Oil Cover Screw for 12478 and 20141.....
211E 1206	Bed Frame Hinge Connection Cap Screw for 19398.....
212D 5755	Edge Guide Screw for 31-37 Machine....
212F 5745	Plaiting Blade Holder (lower) Cap Screw for 31-37 Machine.....
212F 5745	Plaiting Blade Holder (upper) Cap Screw for 31-37 Machine.....
217F 2061	Edge Folder Screw for 35283 and 35284..
217F 2061	" Guide (upper) Screw for 35282.....
217D 1312	Face Plate Screw for 31-35 Machine.....
217D 1312	Vibrating Presser Foot Screw for 31-19 Machine.....
219D 774	Arm Side Cap Screw for 31-15, 31-16, 31-20, 31-22, 31-24, 31-27, 31-32, 31-34, 31-37 and 31-39 Machines.....
219D 774	Face Plate Screw for 31-19 Machine....
219D 774	Hemmer Plate Screw for 120078.....
219F 774	Presser Foot Ribbon Guide Screw for 28761.....
219F 774	Ruffling Arm Set Screw for 26889.....
219F 774	Vibrating Presser Bar Cap Screw for 19367
220D 2038	Binder Folder Screw for 120127.....
220D 1375	Edge Guide Leveling Screw for 26810....
220D 2038	Tucker Tuck Marking Bar Bracket Hinge Pin Set Screw for 26377.....
223F 1317	Knife Screw for 19391.....
223D 2035	Ruffler Guide Screw for 26724.....
225F 5736	Slack Thread Regulator Adjusting Screw for 31-15, 31-16, 31-20, 31-22, 31-24, 31-27, 31-32, 31-34 and 31-37 Machines
225F 1323	Ruffling Regulator Set Screw for 24211..
226D 1371	Oscillating Shaft Crank Slide Block Cap Screw for 19449.....
226D 1371	Ruffler Ruffling Blade Holder Cap Screw for 28816.....
226D 1344	Ruffling Blade Holder Cap Screw for 28845.....
227J —	Knife Grinder Knife Stop Screw for 126393
228D 5746	Plaiting Blade (upper) Screw (left) for 31-37 Machine.....
228D 2038	Presser Foot Adjustable Guide Screw for 26639.....
228D 2038	Presser Foot Extension Screw for 12435 and 20157.....

NO. PLATE	NAME
228D 2038	Presser Foot Strip Gauge Screw for 12435 and 20157.....
228D 2038	Strip Folder Lock Stud Spring Screw for 28707.....
229D 782	Oscillating Shaft Crank Slide Block Cap Screw for 19449, obsolete use 206D....
229D 782	Reciprocating Spring Presser Regulator Crank Roller Cap Screw for 1942.....
233D 782	Binder Binding Guide Set Screw for 25664
233D 782	" Guide (back) Screw for 36463....
233D 782	" " (front) Screw for 36463....
233D 1380	" Ribbon Tension Screw for 28678 and 28776.....
233D 782	Box Plaiter Sliding Bracket Cap Screw for 28352.....
233D 1375	Box Plaiter Sliding Bracket Stop Screw for 28352.....
233D 1375	Edge Guide Slide Cap (right) Screw (small) for 26810.....
233D 1376	Hemmer Folder (left) Screw for 28688...
233D 1376	" Slide Cap Screw (front) for 28688
233D 782	Needle Bar Thread Guide Screw for 31-15, 31-16, 31-19, 31-20, 31-27, 31-32, 31-34, 31-37, 31-39 and 31-42 Machines.....
233D 782	Reciprocating Spring Presser Blade Screw for 20253.....
233D 2039	Welt Guide Width Guide Screw for 26148
236J 5809	Finger Guard Screw for 120498.....
237K 1105	Knife Grinder Knife Holder Stop Collar Set Screw for 27659.....
238D 2039	Welt Guide Cap Screw for 26150.....
238D 782	Oscillating Rock Shaft Oil Pad Holder Screw, obsolete.....
239D 2061	Separating Blade Arm Latch Lever Spring Screw for 35280.....
240D 782	Shuttle Race Slide Spring Screw for 12396 and 20450.....
240D 2039	Welt Guide Carrier Slide Stop Adjusting Screw for 26150.....
241D 5754	Separating Blade Screw for 31-37 Machine
242D 2645	Presser Foot Edge Guide Screw for 28858
248A 2011	Clamp Stop Motion Clamp Stop Screw for 3022.....
256J 2003	Clamp Stop Motion Clamp Screw for 3022
261J 1105	Knife Grinder Knife Regulating Thumb Screw for 60583.....
283D 1379	Binder Thumb Screw for 26956.....

NO. PLATE	NAME
284D 1366	Guide Thumb Screw (long) for 25866, 25873, 25874 and 28658.....
286D 783	Arm Side Cover Thumb Screw.....
286D 5807	Binder Guide Thumb Screw for 36344, 120247 and 120248.....
286D 783	Binder Shank Thumb Screw for 120166..
286D 783	Edge Folder Thumb Screw for 36293....
286D 783	Face Plate Thumb Screw for 31-15, 31-16, 31-20, 31-22, 31-24, 31-27, 31-32, 31-34, 31-37, 31-39 and 31-42 Machines.....
286D 783	Guide Thumb Screw for 28969 and 120428
287D 783	Tucker Edge Guide Slide Thumb Screw for 26597.....
287D 783	Tucker Tuck Guide Plate Thumb Screw for 26683.....
291D 2038	Tucker Cloth Guide Thumb Screw for 26377.....
296C 3826	Band Wheel Crank Screw Centre for 46629.....
296C 5742	Starting Treadle Screw Centre for 46661..
297C 3826	Band Wheel Crank Centre Screw for 46629
297C 3826	Treadle Screw Centre for 46629.....
307C 783	Feed Lifting Rock Shaft Screw Centre for 56814.....
307C 783	Feed Rock Shaft Screw Centre for 56814
310K 1105	Knife Grinder Emery Wheel Shaft Screw Centre for 60583.....
310K 1105	Knife Grinder Knife Holder Guide Bar Bracket Screw Centre for 60583.....
313C 783	Feed Bar Screw Centre for 56813.....
326E 5741	Starting Treadle Extension Screw for 43815.....
333D 782	Bobbin Winder Friction Wheel Washer Screw for 12171, 12201, 16515 and 20308
334D 2038	Binder Folder Slide Carrier Screw for 36463
334D 2038	Binder Pressure Spring Screw for 25650, 25653, 25656, 26694 and 36463.....
334D 2038	Tucker Tuck Marking Bar Set Screw for 26377.....
335H 1317	Knife Holder Handle Screw for 24128....
335H 1317	" " Screw for 24128.....
335D 1317	Presser Foot Graduated Adjustable Guide Screw for 26977.....
335D 1313	Vibrating Presser Bar Spring Screw for 31-19 Machine.....
337D 2645	Binder Ribbon Guide Screw for 28794...

## NUMERICAL LIST OF PARTS

NO. PLATE	NAME
337D 1388	Presser Foot Guide Spring Screw for 26646 and 28773.....
337B 2671	Presser Foot Graduated Adjustable Guide Clamp Screw for 35137.....
337D 1388	Ruffler Ruffling Blade Clamp Screw for 26230 and 26724.....
337D 2061	Separating Blade Screw for 35280.....
337D 1383	Throat Plate Needle Hole Plate Screw for 26760 and 28342.....
337D 2039	Welt Guide Carrier Slide Switch Cam Shaft Head Set Screw for 26139.....
354c 774	Driving Attachment Treadle Pitman Rod (upper) Clamp Screw for 9079.....
354c 1101	Starting Treadle Pitman Rod Clamp Screw for 43813.....
354c 1101	Treadle Pitman Rod Clamp Screw for 9079.....
356c 3817	Band Wheel Shaft Driving Flange Set Screw for 25429.....
356c 783	Rock Shaft Knee Arm Hub Set Screw for 2766 and 20462.....
356c 783	Rock Shaft Knee Arm Plate Set Screw for 2767.....
356c 783	Rock Shaft Lifting Arm Set Screw for 20464.....
356c 783	Rock Shaft Lifting Bracket Hook Set Screw for 6337.....
356c 783	Rock Shaft Lifting Bracket Set Screw for 6337.....
356c 783	Rock Shaft Stop Dog Set Screw for 2770..
362F 2009	Driving Attachment Treadle Stop Collar Set Screw for 2762.....
375c 782	Crank Connecting Rod Hinge Screw, obsolete.....
375c 782	Feed Connecting Link Hinge Screw for 43992, 43993 and 44188.....
375c 782	Feed Forked Connection Hinge Screw for 43992, 43993 and 44188.....
375c 782	Feed Lifting Rock Shaft Crank Connecting Rod Hinge Screw for 31-15, 31-16, 31-19, 31-20, 31-22, 31-24, 31-27, 31-32, 31-34, 31-35 and 31-37 Machines.....
375c 782	Lifting Presser Bar Bell Crank Driving Arm Eccentric Connection Hinge Screw for 31-19 Machine.....
376E 8628	Stop Pawl Wearing Block Screw for 44230
386D 5842	Roller Arm Screw for 1928.....

## NUMERICAL LIST OF PARTS

NO. PLATE	NAME
391D 1366	Shuttle Bobbin Case Position Plate Screw for 24325, 24415 and 24419.....
397D 782	Oil Cover Screw, obsolete.....
401E 2038	Binder Folder Slide Carrier Adjusting Thumb Nut Guide Screw for 36463....
401E 2038	Box Plaiter Folder Blade Screw for 28352
401E 2038	Tucker Cloth Guide Slide Screw for 26377
402D 5752	Plaiting Gear Cover Plate Screw for 20491
413C 783	Tension Screw Stud for 33892, obsolete..
418E 2014	Bobbin Winder Tension Screw Stud for 27308.....
418D 2014	Thread Retainer Screw Stud for 43809...
427E 783	Driving Attachment Driving Arm Friction Plug Adjusting Screw for 16522 and 19260.....
430c 783	Thread Take-up Lever Link Hinge Pin Set Screw for 31-15, 31-16, 31-19, 31-20, 31-22, 31-24, 31-27, 31-32, 31-34, 31-35, 31-37 and 31-39 Machines, obsolete....
435c 5742	Driving Attachment Balance Wheel Set Screw for 16592.....
435c 3817	Driving Arm Hinge Pin Set Screw for 25431 and 25432.....
435c 5806	Thread Take-up Lever Link Hinge Pin Set Screw.....
443c 3817	Band Wheel Brake Lever Hinge Pin Set Screw for 25418, obsolete.....
443c 5752	Plaiting Lever Hinge Stud Set Screw for 20433.....
443c 5740	Stop Pawl Hinge Pin Set Screw for 12312
446c 783	Feed and Feed Lifting Eccentric Set Screw for 12428 and 20283.....
446c 783	Feed Cam and Feed Lifting Eccentric Set Screw for 12197.....
446c 783	Stop Wheel Set Screw for 43807 and 43943
447F 2038	Binder Leveling Screw for 25657.....
448c 783	Arm Shaft Bushing (back) Set Screw for 31-42 Machine.....
448c 783	Arm Shaft Flanged Bushing (back) Set Screw for 31-15, 31-16, 31-19, 31-20, 31-22, 31-24, 31-27, 31-32, 31-34, 31-35, 31-37 and 31-39 Machines.....
448c 783	Balance Wheel Set Screw for 4370 and 12358.....
448c 783	Lifting Lever Pin Set Screw for 12237 and 20340.....



NO. PLATE	NAME
448c 783	Needle Bar Crank and Lifting Cam Set Screw for 43803.....
448c 783	Needle Bar Crank and Lifting Eccentric Set Screw for 19365.....
448c 783	Needle Bar Crank Set Screw for 16569...
448c 783	Oscillating Rock Shaft Hinge Pin Set Screw.....
448c 783	Presser Bar Lifting Lever Pin Set Screw for 12284.....
448c 783	Strip Folder Hinge Bracket Set Screw for 28706.....
448c 783	Table Belt Guide (lower) Pulley Shaft Set Screw for 14229.....
448c 783	Table Belt Guide (upper) Pulley Shaft Set Screw for 10857.....
448c 783	Thread Take-up Spring Regulator Set Screw.....
449c 5746	Plaiting Gear (intermediate) Stud Set Screw for 20423.....
453c 783	Lifting Presser Bar Guide Bracket Set Screw for 19363 and 24589.....
453c 783	Needle Bar Connecting Stud Set Screw for 12384 and 20368.....
453c 783	Oscillating Shaft Crank Set Screw for 44135
453c 783	Presser Bar Guide Bracket Set Screw for 12326, 20059 and 43917.....
453c 783	Reciprocating Spring Presser Shaft Crank (front) Set Screw for 20252.....
453c 1323	Ruffling Eccentric Collar Set Screw for 24208.....
453c 1323	Ruffling Eccentric Set Screw for 24207...
453c 783	Thread Unwinder Thread Guard Rod Set Screw for 27940.....
456c 773	Reciprocating Spring Presser Shaft Collar Set Screw for 20251.....
456c 773	Thread Unwinder Thread Guard Rod Coupling Set Screw for 41639.....
457c 5806	Corder Cord Guide Bed Leveling Screw for 120206.....
457c 783	Oscillating Shaft Crank Set Screw for 12390 and 19447.....
458c 5750	Plaiting Eccentric Set Screw for 20424...
460c 783	Oscillating Shaft Crank Set Screw for 19447, obsolete.....
460c 1323	Ruffling Arm Shaft Collar Set Screw for 6533.....

NO. PLATE	NAME
460c 783	Thread Retainer Set Screw for 31-15, 31-16, 31-19, 31-20, 31-22, 31-24, 31-27, 31-32, 31-35, 31-37 and 31-39 Machines, obsolete.....
460c 783	Thread Retainer Stud Set Screw for 12402, obsolete.....
462c 773	Clamp Stop Motion Flanged Bushing Set Screw for 4933.....
462c 773	Feed Lifting Rock Shaft Crank (back) Set Screw for 3043 and 12200, obsolete....
462c 773	Shuttle Driver Set Screw for 12444 and 19406, obsolete.....
465f 6252	Edge Guide Bed Leveling Screw for 36187
468c 2038	Box Plaiter Sliding Bracket Locking Pin Spring Bushing Set Screw for 26439...
514c 2038	Box Plaiter Sliding Bracket Locking Pin for 28352.....
534r 3817	Driving Segment Bolt with 1510r, for 25255.....
560b 984	Ruffler Ruffling Blade Lever Adjusting Thumb Screw for 26230 and 28816....
578d 5837	Throat Plate Cutting Bar Screw for 5732
578d 5837	" " Slide Adjusting Screw for 5732.....
589b 2038	Binder Guide (upper) Clamping Screw for 25658 and 25659.....
591f 782	Shuttle Tension Regulating Screw for 12417, 19293, 20591, 20651, 20653, 20756, 24074 and 62740.....
592e 782	Shuttle Bobbin Case Latch Stop Screw for 12417, 19293, 20591, 20651, 20653, 20756, 24074 and 62740.....
597c 2011	Driving Attachment Shaft Driving Pulley Clamping Screw for 27072.....
602d 8628	Quilter Guide Disengaging Sleeve Spring Screw for 120485.....
620f 782	Knife Adjusting Screw for 19391.....
620f 782	Needle Bar Thread Guard Set Screw for 16568.....
621b 1317	Knife Bar Lifting Spring Guide Bracket Screw for 24128.....
624b 8628	Thread Retainer Set Screw for 31-15, 31-16, 31-19, 31-20, 31-22, 31-24, 31-27, 31-32, 31-34, 31-35, 31-37 and 31-39 Machines.....
647c 774	Knife Bar Driving Crank Bracket Screw for 31-35 Machine.....

NO. PLATE	NAME
647F 774	Shuttle Race Screw, obsolete, use 145D...
648D 782	" " Back Spring Screw for 5707, 12489, 19404, 20005 and 24010.....
651D 2011	Hemmer Block Spring Screw for 120078..
651D 2011	Needle Clamp Thread Guard Screw for 24103.....
656E 2038	Binder Folder Slide Carrier Adjusting Screw 25672.....
656E 2038	Binder Guide (centre) Screw for 25657...
662D 2035	Ruffler Separating Blade Screw for 26670 and 26671.....
662D 782	Shuttle Race Cap Screw for 5707, 12489, 19404 and 20005.....
665D 1388	Binder Folder Guide Screw for 120120...
665D 1388	Presser Foot Braid Guide Screw for 36182
665D 5645	" " Cord Guide Screw for 36022
665D 2633	" " Guide Screw for 28353.....
665D 1388	" " Spring Guide Screw for 28726 and 28909.....
665D 1371	Ruffler Ruffing Blade Screw for 28816...
665D 1344	Ruffing Blade Screw for 28845.....
671D 5807	Binder Edge Guide Thumb Screw for 36344
671D 1314	" Folder and Ribbon Tension Thumb Screw for 26701.....
688J 783	Pressure Regulating Thumb Screw for 31-15, 31-16, 31-19, 31-20, 31-22, 31-24, 31-27, 31-32, 31-34, 31-35, 31-37 and 31-42 Machines.....
689C 782	Lifting Presser Bar Lifter Screw for 31-19 Machine.....
689C 782	Presser Bar Lifter Screw for 31-15, 31-16, 31-20, 31-22, 31-24, 31-27, 31-32, 31-34, 31-35 and 31-37 Machines.....
690E 782	Thread Take-up Crank Wedge Screw....
691F 782	Throat Plate Screw.....
692D 783	Bobbin Winder Bracket Screw for 12172, 12202, 12337, 20309 and 20498.....
692D 783	Driving Attachment Bracket Screw for 12478 and 20141.....
692D 783	Starting Bell Crank Bracket Screw for 31-42 Machine.....
693D 782	Driving Attachment Driving Arm Hinge Screw for 16522 and 19260.....
696E 782	Needle Bar Plug Screw, obsolete.....
706D 1371	Presser Foot (right) Shank Stop Screw for 28816.....

NO. PLATE	NAME
714D 5755	Strip Guide Thumb Screw for 31-37 Ma- chine.....
725E 1387	Shuttle Race Slide Spring Screw for 12432
725E 1387	Presser Foot Adjustable Guide Screw for 26802.....
732D 1366	Guide Thumb Screw (short) for 25866, 25873, 25874 and 28658.....
732D 1366	Tucker Tuck Guide Plate Bracket Thumb Screw for 26683.....
742E 1323	Ruffing Eccentric Connection Cap Screw for 24219.....
743C 1313	Needle Bar Crank and Lifting Eccentric Position Screw for 19365.....
743C 1317	Needle Bar Crank Position Screw for 16569
748E 782	Arm Screw (back).....
748R 3817	Brace Screw for 25255, 25265, 25279 and 25284.....
766D 782	Lifting Lever Link Hinge Screw (Foot and Knee Lifters) for 12445, 20008, 20256, 20290, 20341, 20466, 43928, 43929, 43930, 43931, 43933 and 43934.....
766D 782	Presser Bar Lifting Lever Link Hinge Screw for 31-42 Machine.....
775E 782	Presser Bar Lifting Lever Lifter Roller Cap Screw for 12286.....
775E 782	Thread Take-up Lever Cap Screw for 43990, 43991 and 44179.....
794E 782	Needle Bar Connecting Link Adjusting Screw for 12196 and 12382.....
794E 5752	Plaiting Lever Connecting Rod Adjusting Screw for 20434.....
800C 5739	Presser Bar Lifting Lever Lifter Adjusting Screw for 31-42 Machine.....
801E 5739	Presser Bar Lifting Lever Lifter Hinge Screw for 31-42 Machine.....
802D 782	Lifting Lever Hinge Screw (Foot and Knee Lifters) for 12445, 20008, 20256, 20290, 20341, 20466, 43928, 43929, 43930, 43931, 43933 and 43934.....
802D 782	Presser Bar Lifting Lever Hinge Screw for 31-42 Machine.....
808F 782	Needle Clamp Screw for 4303 and 24103..
808F 782	Ruffler Needle Clamp Screw for 26017...
811D 5742	" Ruffing Blade Hinge Screw for 26018.....
812B 984	Ruffler Ruffing Blade Lever Adjusting Thumb Screw for 26018 and 26724....

NO. PLATE	NAME
818D 783	Feed Regulator Thumb Screw for 43993 and 44188.....
834D 5740	Feed Regulating Thumb Screw for 31-32 Machine.....
835D 5740	Feed Regulator Handle Screw for 31-32 Machine.....
840D 5740	Stop Wheel Block Screw for 43807 and 43943.....
854E 783	Arm Screw (front).....
855c 783	Needle Bar Crank Position Screw for 12385, obsolete.....
858c 783	Needle Bar Crank Set Screw for 12385 and 20188.....
858c 783	Table Belt Guide (lower) Pulley Shaft Oil Hole Plug Screw for 14231.....
861D 5742	Driving Attachment Driving Friction Pulley Oil Hole Plug Screw for 16594..
878J 783	Oscillating Rock Shaft Hinge Pin Oil Hole Stop Screw, obsolete.....
879D 2026	Corder Arm Locking Screw for 25792....
880R 5843	Brace Section Screw for 46662.....
882c 5752	Plaiting Gear (front) Set Screw for 20426
896E 773	Crank Connecting Rod Cap Screw for 12365, 12496 and 20197.....
899J 1105	Knife Grinder Knife Clamping Screw for 27658, 27681, 27682 and 126393.....
904F 8628	Needle Set Screw for 16568.....
907D 782	Shuttle Race Back Spring Screw for 24120, 24325, 24415 and 24419.....
908c 773	Crank Connecting Rod Hinge Screw.....
910F 2039	Welt Guide Adjusting Screw for 26150...
914F 2038	Box Plaiter Sliding Bracket Arm Screw for 28352.....
936E 773	Needle Bar Screw Bushing for 31-15, 31-16, 31-19, 31-20, 31-22, 31-24, 31-27, 31-32, 31-34, 31-37, 31-39 and 31-42 Machines.....
939D 5843	Tucker Edge Guide Thumb Screw for 26685.....
940D 5742	Binder Arm Hinge Screw for 120166....
940F 1366	Edge Folder Holder Hinge Screw for 36293
940D 5742	Guide Holder Hinge Screw for 28969 and 120428.....
965D 1312	Lifting Presser Bar Bell Crank Driving Arm Shaft Bracket Screw for 31-19 Machine.....

NO. PLATE	NAME
966E 5806	Feed Lifting Rock Shaft Crank Connecting Rod Cap Screw for 12430 and 43976...
972c 3826	Band Wheel Set Screw for 25301.....
988c 2011	Oscillating Shaft Crank Slide Block Screw Stud for 19449.....
1036c 7790	Binder Leveling Screw for 120242.....
1036c 5806	" " " (back) for 36340..
1044D 1377	Corder Cord Guide Arm Hinge Screw for 120207.....
1049D 1371	Ruffler Ruffling Blade Lever Stop Screw for 28816.....
1053D 2006	Shuttle Bobbin Case Guide Plate Screw for 24120, obsolete.....
1053D 2006	Shuttle Race Cap Screw for 24998, 25000, 62502 and 62623.....
1054c 5837	Starting Bell Crank Roller Screw Stud for 1885.....
1065c 2011	Needle Bar Crank Position Screw for 20188.....
1072F 1317	Needle Set Screw for 16568, obsolete.....
1099F 2019	Reciprocating Spring Presser Blade Holder Hinge Screw for 20253.....
1101c 2035	Ruffler Driving Lever Hinge Screw for 26724 and 28816.....
1108F 1323	Ruffling Regulator Thumb Screw for 31-27 Machine.....
1115F 1370	Tucker Needle Clamp Screw for 26719...
1115F 1370	Ruffler Needle Clamp Screw for 26719...
1128E 1366	Feed Regulator and Reverser Hinge Screw for 31-32 Machine.....
1128E 2009	Feed Regulator Hinge Screw for 31-15, 31-16, 31-19, 31-20, 31-22, 31-24, 31-27, 31-34, 31-35 and 31-37 Machines.....
1141D 5806	Binder Guide (lower) Screw Stud for 26696.....
1149c 5742	Thread Unwinder Spool Rest Set Screw for 60455 and 60701.....
1162c 1366	Knife Bar Crank Coupling Pin for 24432
1253c 5740	Presser Bar Stop Collar Set Screw for 43804.....
1266c 5806	Binder Leveling Screw (front) for 36340..
1266c 5806	Shuttle Driver Set Screw for 12444 and 19406.....
1312c 3817	Band Wheel Set Screw for 25329.....
1362c 5739	Needle Bar Crank and Lifting Cam Position Screw for 43803.....
1368J 8630	Binder Screw for 120494 and 120495.....

NO. PLATE	NAME
1423D 5742	Ruffling Separating Blade Screw for 31-27 Machine.....
1425R 5742	Binder Folder Hinge Screw for 35354....
1425D 6252	Edge Guide Arm Hinge Screw for 36188..
1425D 932	Hemmer Folder Hinge Screw for 35681...
1443J 8625	" Shank Screw.....
1480D 8628	Belt Guard Retaining Screw for 126365
1494D 5739	Driving Pulley Screw for 31-42 Machine
1507R 3826	Band Wheel Crank Screw Centre Nut for 46629.....
1507R 5742	Starting Treadle Screw Centre Nut for 46661.....
1507R 3826	Treadle Screw Centre Nut for 46629....
1508C 783	Driving Attachment Driving Arm Friction Plug Adjusting Screw Nut for 16522 and 19260.....
1508J 1105	Knife Grinder Emery Wheel Clamping Nut for 60934.....
1508R 3817	Leg Stay Rod Nut for 25255.....
1510R 3817	Driving Segment Bolt Nut for 534.....
1513J 783	Feed Lifting Rock Shaft Screw Centre Nut for 56814.....
1513J 783	Feed Rock Shaft Screw Centre Nut for 56814.....
1513J 783	Starting Bell Crank Roller Screw Stud Nut for 12344.....
1516J 1105	Knife Grinder Emery Wheel Shaft Screw Centre Nut for 60583.....
1516J 1105	Knife Grinder Knife Holder Guide Bar Bracket Screw Centre Nut for 60583..
1517J 5740	Starting Bell Crank Hinge Screw Nut for 12344.....
1518J 783	Crank Connecting Rod Hinge Screw Nut for 375, obsolete.....
1518J 783	Feed Connecting Link Hinge Screw Nut for 43992, 43993 and 44188.....
1518J 783	Feed Forked Connection Hinge Screw Nut for 43992, 43993 and 44188.....
1518J 783	Feed Lifting Rock Shaft Crank Connecting Rod Hinge Screw Nut for 31-15, 31-16, 31-19, 31-20, 31-22, 31-24, 31-27, 31-32, 31-34, 31-35 and 31-37 Machines
1518J 783	Lifting Presser Bar Bell Crank Driving Arm Eccentric Connection Hinge Screw Nut for 31-19 Machine.....
1518J 783	Oscillating Shaft Crank Roller and Screw Stud Nut for 12390, obsolete.....

NO. PLATE	NAME
1518J 783	Oscillating Shaft Crank Slide Block Screw Stud Nut for 19447 and 44135.....
1518J 783	Reciprocating Spring Presser Regulator Crank Roller and Screw Stud Nut for 20247.....
1519J 783	Feed Bar Screw Centre Nut for 56813...
1520J 783	Lifting Presser Bar Lifter Screw Nut for 31-19 Machine.....
1520R 3826	Pitman Rod Lock Nut for 46520.....
1520R 3826	" " (upper) Lock Nut for 46656
1520J 783	Presser Bar Lifter Screw Nut for 31-15, 31-16, 31-20, 31-22, 31-24, 31-27, 31-32, 31-34, 31-35 and 31-37 Machines.....
1520J 5739	Presser Bar Lifting Lever Lifter Adjusting Screw Nut for 31-42 Machine.....
1521E 772	Lifting Lever Connecting Rod Lock Nut (Foot and Knee Lifters) for 12445, 20008, 20256, 20290, 20341, 20466, 43928 to 43931, 43933 and 43934.....
1521J 5753	Plaiting Rock Shaft Lever Connecting Rod Crank Roller and Screw Stud Nut for 31-37 Machine.....
1528D 5842	Roller Arm Screw Nut for 1928.....
1536D 6254	Binder Folder Slide Carrier Adjusting Thumb Nut for 36463.....
1550H 783	Bobbin Winder Stop Latch Adjusting Screw Nut for 16516 and 19258.....
1550H 5745	Plaiting Blade Holder (lower) Spring Stop Screw Nut for 31-37 Machine.....
1550H 5745	Plaiting Blade Holder (upper) Spring Stop Screw Nut for 31-37 Machine.....
1550J 783	Presser Foot Roller Screw Nut for 20243..
1550H 1371	Ruffler Ruffling Blade Holder Stud Nut for 28816.....
1550H 1344	Ruffling Blade Holder Stud Nut for 28845
1560C 783	Tension Regulating Thumb Nut for 33892 and 44141.....
1562J 2014	Bobbin Winder Tension Regulating Thumb Nut for 27308.....
1562J 2014	Thread Retainer Regulating Thumb Nut for 43809.....
1564D 2038	Box Plaiter Sliding Bracket Locking Pin Head for 28352.....
1564D 2038	Knife Bar Crank Coupling Pin Head for 24432.....
1566D 2024	Binder Guide (centre) Thumb Nut for 25664.....

NO.	PLATE	NAME
1566D	2024	Binder Guide (lower) Thumb Nut for 26694
1571D	1949	Binder Guide (upper) Clamping Thumb Nut for 25664.....
1577D	2024	Binder Folder Guide (upper) Thumb Nut for 25650, 25653 and 25656.....
1579C	783	Driving Attachment Driving Arm Hinge Screw Nut for 16522 and 19260.....
1582D	984	Ruffler Driving Lever Spring Adjusting Nut for 26230.....
1603E	984	Ruffler Ruffing Blade Lever Adjusting Thumb Screw Nut for 26230 and 28816
1619E	773	Crank Connecting Rod Hinge Screw Nut
1620J	5806	Bobbin Winder Frame Hinge Screw Nut for 27647, 27650, 27651 and 27875.....
1621E	984	Ruffler Ruffing Blade Lever Adjusting Thumb Screw Nut for 26018 and 26724
1640C	2035	Ruffler Driving Lever Spring Adjusting Nut for 26724.....
1641E	1323	Ruffing Regulator Stop Screw Nut for 31-27 Machine.....
1641E	1323	Ruffing Regulator Thumb Screw Nut for 31-27 Machine.....
1647C	1371	Ruffler Driving Lever Hinge Screw Nut for 28816.....
1648E	5740	Pressure Regulating Thumb Screw Lock Nut for 31-42 Machine.....
1666D	984	Ruffler Driving Lever Spring Adjusting Nut for 26018.....
1667R	5750	Plaiting Cam Thumb Nut for 31-37 Machine.....
1668C	5745	Plaiting Blade Holder (lower) Hinge Stud Nut for 31-37 Machine.....
1668C	5745	Plaiting Blade Holder (upper) Hinge Stud Nut for 31-37 Machine.....
1668J	5752	Plaiting Regulating Stud Nut for 31-37 Machine.....
1670R	3826	Pitman Rod Ball Screw Bearing Nut for 46630.....
1670R	3826	Pitman Rod (lower) Ball Screw Bearing Nut for 46630.....
1813	783	Feed Lifting Rock Shaft Crank Roller and Stud for 12376.....
1852	1377	Guide Roller for 28658.....
1885	5740	Starting Bell Crank Roller with 190D, 1054C and 5968, for 12344.....
1902	783	Oscillating Shaft Crank Roller and Screw Stud for 12390, obsolete.....

NO.	PLATE	NAME
1904	770	Needle Bar Connecting Stud Roller (roller only) for 12384.....
1904	770	Reciprocating Spring Presser Regulator Crank Roller (roller only) for 1942....
1928	2039	Roller, 1¼ in. diam., fine, with 386D and 1528D, for 19394.....
1942	2019	Reciprocating Spring Presser Regulator Crank Roller and Screw Stud with 229D, 1904 and 12424, for 20247.....
1943	1370	Tucker Needle Clamp Roller for 26719...
1943	1370	Ruffler Needle Clamp Roller for 26719...
1961	5753	Plaiting Rock Shaft Lever Connecting Rod Crank Roller and Screw Stud for 20444.....
1976	5739	Presser Bar Lifting Lever Lifter Roller (roller only) for 12286.....
1988	6252	Edge Guide Arm Roller and Screw Stud for 36185.....
2018	1101	Starting Bell Crank Pitman Stud Washer for 12344.....
2020	2003	Clamp Stop Motion Clamp Washer for 3022.....
2022	773	Clamp Stop Motion Flanged Bushing Pin for 31-15, 31-16, 31-19, 31-20, 31-22, 31-24, 31-27, 31-32, 31-34, 31-35 and 31-39 Machines.....
2022	773	Driving Attachment Driving Arm Pitman Crank Pin for 44176.....
2022	773	Driving Attachment Starting Crank Pin for 44176.....
2022	773	Knife Bar Crank Pin for 24433.....
2049	773	Feed Lifting Rock Shaft Crank (back) Pin, obsolete.....
2049	773	Lifting Presser Bar Bell Crank Driving Arm Pin for 19361.....
2049	773	Oscillating Shaft Crank Pin.....
2049	773	Reciprocating Spring Presser Shaft Crank (back) Pin for 31-24 Machine.....
2049	773	Shuttle Driver Pin.....
2062	771	Presser Bar Lifter for 31-15, 31-16, 31-20, 31-27, 31-32, 31-34, 31-35 and 31-37 Machines.....
2102	3471	Bobbin Winder Tension Disc for 225462..
2102	5806	Tension Disc for 44118 and 44149.....
2106	2014	Bobbin Winder Tension Thread Guide for 27308.....

NO.	PLATE	NAME
2113	1388	Presser Foot Guide Spring Steady Pin for 28773.....
2135	2000	Balance Wheel (stand) heavy rim, 2½ in. pulley, for 3022, for 31-15, 31-16, 31-19, 31-20, 31-22, 31-24, 31-27, 31-32, 31-34, 31-35 and 31-39 Machines.....
2269	773	Bobbin Winder Stop Latch Stop Pin for 16518.....
2269	773	Driving Pulley Spring Washer Stop Pin for 43806 and 43941.....
2273	2038	Strip Folder Stop Pin for 28706.....
2291	1317	Knife Screw Washer for 19391.....
2291	1344	Ruffling Arm Adjusting Screw Washer for 26890.....
2296	2038	Box Plaiter Sliding Bracket Locking Pin Spring Bushing for 28352.....
2297	2038	Box Plaiter Sliding Bracket Locking Pin Spring for 28352.....
2297	2038	Knife Bar Crank Coupling Pin Spring for 24432.....
2301	5843	Box Plaiter Sliding Bracket Stop Pin for 28349 and 28350.....
2301	1317	Knife Bar Stop Pin for 19297.....
2301	2035	Ruffler Ruffling Blade Lever Disengaging Lever Stop Pin for 26724.....
2362	1375	Edge Guide Slide Cap (left) Steady Pin for 26803.....
2362	1376	Hemmer Folder (left) Steady Pin for 28682.....
2362	1376	Hemmer Folder Disengaging Lever Stop Pin for 28682.....
2419	2006	Shuttle Race Back for 19404, 24010, 24120 and 24325.....
2455	2014	Bobbin Winder Tension Disc for 27308..
2455	2014	Thread Retainer Disc for 43809.....
2521	1371	Presser Foot (right) Spring for 28814....
2521	1371	Shuttle Bobbin Case Latch Spring for 20591 and 20653, obsolete.....
2523	771	Shuttle Bobbin Case Position Finger Rivet for 12417, 19293, 20591, 20651, 20653, 20756, 24074 and 62740.....
2523	1317	Knife Bar Lifting Spring Guide Pin for 24906.....
2526	5842	Shuttle Tension Spring for 12417, obsolete, use 15098.....
2531	767	Shuttle Race Back for 5707, 12489, 20005, 24415 and 24419.....

NO.	PLATE	NAME
2532	772	Presser Foot Hinge Pin for 20157, 20311, 20346 and 24489, obsolete.....
2532	1371	Presser Foot (right) Hinge Pin for 28814, obsolete.....
2532	772	Shuttle Race Back Position Pin for 5707, 12489, 19404, 20005, 24010, 24120, 24325, 24415 and 24419.....
2533	767	Shuttle Race Back Spring for 5707, 12489, 19404, 20005, 24010, 24120, 24325, 24415 and 24419.....
2653	2671	Presser Foot Graduated Adjustable Guide Clamping Lever Hinge Pin for 28953..
2656	1371	Presser Foot (right) Shank Spring for 28816
2656	2669	" " Tension Plate Spring for 35447
2749	5742	Binder Folder Hinge Screw Friction Washer for 35354.....
2762	1206	Driving Attachment Treadle Stop Collar with 362F, for 14233 and 15130.....
2763	819	Rock Shaft for 4880 and 12250.....
2764	5735	" " Hanger (back) with two wood screws 1 in. No. 10, for 20465.....
2765	5735	Rock Shaft Knee Arm for 2768 and 20463
2766	766	" " " " Hub with 356c, for 2768.....
2767	5735	Rock Shaft Knee Arm Plate with 356c, for 2768 and 20463.....
2768	—	Rock Shaft Knee Arm complete, for 12250 Nos. 2765 to 2767.....
2770	819	Rock Shaft Stop Dog with 356c, for 4880, 12250 and 20465.....
2778	766	Rock Shaft Lifting Bracket Hook for 12250
2809	8633	Machine Hinge Connection Hinge Pin for 44244.....
2827	773	Face Plate Thread Guard (upper) with 8505, for 12367, 16559, 19355 and 20058
2862	—	Balance Wheel (stand) heavy rim, 3 in. pulley, for 3022, for 31-15, 31-16, 31-19, 31-20, 31-22, 31-24, 31-27, 31-32, 31-34, 31-35 and 31-39 Machines.....
2877	818	Driving Attachment Treadle Pitman Rod (upper) for 15130, obsolete.....
2878	363	Starting Treadle Stand for 43815.....
2878	363	Driving Attachment Treadle Stand for 27642, obsolete.....
2921	772	Tension Disc for 44147.....
2923	772	Tension Spring for 44147 and 44149.....

NO.	PLATE	NAME
2928	774	Driving Attachment Driving Arm Brake (leather) for 16518.....
2972	771	Shuttle Bobbin Case Latch for 15003, obsolete.....
2973	771	Shuttle Bobbin Case Latch Lever for 15003, 15141, 20650 and 20652.....
2974	771	Shuttle Bobbin Case Latch Lever Fulcrum Pin for 15003, 15141, 20592, 20650 and 20652.....
2975	771	Shuttle Bobbin Case Latch Spring for 12417, 19293, 20651, 20756, 24074 and 62740.....
2996	771	Shuttle Bobbin for 12392, 12487 and 19292
3022j	—	Clamp Stop Motion complete for 31-15, 31-16, 31-19, 31-20, 31-22, 31-24, 31-27, 31-32, 31-34, 31-35 and 31-39 Machines, Nos. 248A, 256j, 2020 and 4933.....
*3023	—	Clamp Stop Motion Flanged Bushing for 4933.....
3033	770	Feed Connecting Link for 43992, 43993 and 44188.....
3039	768	Feed Regulator for 43993 and 44188.....
3043	770	" Lifting Rock Shaft Crank (back) with 462c, for 12375, 12380 and 20239, obsolete.....
3094	773	Thread Take-up Crank Wedge.....
3146	1353	Binder Thumb Screw Washer for 120533
3146	1353	Guide Thumb Screw Washer for 25866, 25873, 25874, and 28658.....
4302	773	Needle Bar Thread Guide for 31-15, 31-16, 31-19, 31-20, 31-27, 31-32, 31-34, 31-37, 31-39 and 31-42 Machines.....
4303	773	Needle Clamp with 808f, for 31-15, 31-16, 31-19, 31-20, 31-27, 31-32, 31-34, 31-37, 31-39 and 31-42 Machines.....
4307	772	Shuttle Race Slide Spring for 12396, 12432 and 20450.....
4370	2000	Balance Wheel (stand) heavy rim, 2¾ in. pulley, with two 448c, for 31-15, 31-16, 31-19, 31-20, 31-22, 31-24, 31-27, 31-32, 31-34, 31-35, 31-37 and 31-39 Machines
4604	2027	Corder Bow Rivet for 26649 and 26938..
4604	2061	Separating Blade Holder Spring Stop Pin for 35280.....
4604	2038	Tucker Cloth Guide Slide Rivet for 26377
4604	2038	Tucker Tuck Smoothing Spring Rivet for 26377.....

NO.	PLATE	NAME
4621	5843	Shuttle Race Cap Steady Pin for 19404, obsolete.....
4784	1353	Oscillating Rock Shaft Oil Pad for 12387, 12498 and 24105.....
4822	2045	Wrench for 1521 and 1528 (Attachments and Accessories).....
4855	1312	Lifting Presser Bar Lifter for 31-19 Machine.....
4879	2004	Foot Lifter Chain Connecting Link for 4885.....
4880	819	Foot Lifter Rock Shaft complete for 20008 20290, 43928 and 43929, Nos. 2763, 2770, 7125, 12243 and two each 6337 and 12242 (Foot Lifters).....
Nos. 4881 to 4884 FOR 4885		
4881	819	Treadle.....
4882	2004	" Shaft.....
4883	2004	" Spring.....
4884	819	" Stand.....
4885	819	Foot Lifter Treadle complete for 20008, 20290, 43928 and 43929, Nos. 4879, 4881 to 4884 and two wood screws 1 in. No. 16 (Foot Lifters).....
4933	2003	Clamp Stop Motion Flanged Bushing 3023 with two 462c, for 3022j.....
5564	3817	Band Wheel Shaft Driver (left) Clutch Spring Hook for 25424.....
5564	3817	Band Wheel Shaft Driver (right) Clutch Spring Hook for 25428.....
5596	768	Bell Crank for 56848.....
5598	768	Bell Crank complete, for 12445, 20008, 20256, 20290, 20341, 20466, 43928 to 43931, 43933 and 43934, Nos. 5735 and 56848 (Foot and Knee Lifters).....
5599	768	Bell Crank Bracket for 56848.....
5601	773	" " Hinge Pin for 56848.....
5670	—	Foot Lifter Chain, length 26 in. to 35 in. (Foot Lifters) for 20008, 20290, 43928 and 43929.....
5707	767	Shuttle Race complete for 31-15 and 31-16 Machines, Nos. 648b, 2531, 2533, 5708, 5709 and two each 662b and 2532, obsolete.....
5708	—	Shuttle Race Body for 5707, obsolete....
5709	767	" " Cap for 5707, obsolete.....
5726	1271	Knife for 31-35 Machine.....

## NUMERICAL LIST OF PARTS

NO.	PLATE	NAME
		Nos. 5729 to 5731 FOR 5732
5729	—	Throat Plate Body.....
5730	1271	“ “ Cutting Bar.....
5731	1271	“ “ Slide.....
5732	1271	Throat Plate complete for 19103 and 24573, Nos. 5729 to 5731 and three 578D.....
5735	1353	Bell Crank Spring for 5598.....
5944	5843	Tucker Tuck Guide Plate Guide Pin for 26571.....
5960	768	Bobbin Winder Friction Wheel (leather) for 12171, 12201, 16515, 20308, 43982 and 43983.....
5961	768	Bobbin Winder Friction Wheel Washer for 12171, 12201, 16515, 20308, 43982 and 43983.....
5963	768	Bobbin Winder Spindle Flange for 12171, 12201, 16515, 20308, 43982 and 43983..
5968	5837	Starting Bell Crank Roller Screw Washer for 1885.....
5990	2011	Presser Bar Lifter for 31-22 Machine....
6037	1377	Corder Cord Guide Bracket Rivet for 26796.....
6055	5741	Driving Attachment Treadle Pitman Rod (lower) Spring Washer for 14233 and 15130.....
6055	5843	Machine Hinge Bolt Nut Washer for 44180.....
6055	5741	Starting Treadle Extension Bolt Nut Washer for 43815.....
6055	5741	Starting Treadle Extension Screw Washer for 43815.....
6267	2028	Hemmer Folder.....
6337	819	Rock Shaft Lifting Bracket with two 356c, for 4880 and 12250.....
6533	1323	Ruffing Arm Shaft Collar with 460c, for 31-27 Machine.....
7071	1379	Binder Folder Screw Washer for 26250, 26402, 26466, 26953, 28657, 28678, 28776, 28784, 28794, 28861, 120437, 120459 and 120467.....
7071	2021	Binder Guide (upper) Screw Washer for 25664 and 26694.....
7071	2021	Binder Pressure Spring Screw Washer for 25650, 25653, 25656 and 26694.....

## NUMERICAL LIST OF PARTS

NO.	PLATE	NAME
7071	2021	Binder Ribbon Tension Screw Washer for 26250, 26402, 26466, 28657, 28784, 120127, 120437 and 120459.....
7071	2645	Binder Screw Washer for 25664 and 28828
7071	2021	“ Shank Thumb Screw Washer for 120166.....
7071	2645	Binder Strip Guide Screw Washer for 28861
7071	2021	Box Plaiter Centre Guide Holder Screw Washer for 28352.....
7071	1379	Edge Folder Thumb Screw Washer for 36293.....
7071	2021	Guide Thumb Screw Washer for 28969 and 120428.....
7071	2021	Strip Folder Holder and Guide Screw Washer for 35351.....
7071	2021	Tucker Edge Guide Slide Thumb Screw Washer for 26597.....
7071	2021	Tucker Tuck Guide Plate Thumb Screw Washer for 26683.....
7071	2021	Welt Guide Screw Washer for 26150.....
7125	819	Rock Shaft Lifting Bracket Hook for 4880 and 5670.....
7298	2014	Presser Foot Hinge Pin for 19336, 20270 and 120144.....
7336	772	Thread Take-up Spring Regulator for 44118, 44147 and 44149.....
7476	2038	Binder Folder Guide Block Rivet for 36457
7483	2019	Reciprocating Spring Presser Blade Spring Hook for 20252.....
7539	766	Rock Shaft Hanger with two wood screws 1 in. No. 10, for 12250.....
7553	771	Shuttle Bobbin Case Position Finger for 12417, 19293, 24074 and 62740..
7806	5838	Binder Folder Screw Washer for 120127..
7806	2645	“ Ribbon Guide Screw Washer for 28794.....
7958	5741	Starting Treadle Pitman Stud Pin for 31-42 Machine.....
7958	5741	Driving Attachment Balance Wheel Friction Ring Stop Pin for 16592.....
7958	5741	Motor Pitman Pin for 25279.....
8386	5746	Plaiting Cam Position Pin for 20422.....
8418	5842	Belt Guard Button for 8420.....
8419	5842	“ “ “ Washer (leather) for 8420.....



## NUMERICAL LIST OF PARTS

NO.	PLATE	NAME
8420	—	Belt Guard Button 8418 with 8419 and wood screw 1¼ in. No. 9 R. H. B., for 41931.....
8505	773	Face Plate Thread Guard (upper) Rivet for 2827.....
8505	773	Ruffler Ruffling Blade Rivet for 26010...
8511	773	Thread Take-up Spring for 44147 and 44149, obsolete.....
8582	773	Arm Dowel Pin.....
8905	5745	Plaiting Blade Holder (lower) Hinge Stud Nut Washer for 31-37 Machine.....
8905	5745	Plaiting Blade Holder (upper) Hinge Stud Nut Washer for 31-37 Machine.....
8908	2045	Wrench for 1519, 1520 and 1620 (Attachments and Accessories).....
8909	2045	Wrench for 1513, 1517, 1518 and 51581 (Attachments and Accessories).....
8975	8628	Binder Guide (lower) Rivet for 25664....
9079	5844	Driving Attachment Treadle Pitman Rod (upper) Clamp with 354c, for 14233 and 15130.....
9079	5844	Treadle Pitman Rod Clamp with 354c, for 67177.....
9082	773	Driving Attachment Treadle Bearing Cotter Pin for 27642, obsolete.....
9082	773	Starting Treadle Bearing Cotter Pin for 43815.....
9331	8628	Belt Guard Extension Screw Washer for 126365.....
9525	5753	Plaiting Rock Shaft Lever Connecting Rod Crank Roller and Screw Stud Nut Washer for 31-37 Machine.....
9558	2038	Binder Folder Steady Pin for 26695.....
9754	5746	Plaiting Gear (intermediate) Position Pin for 20428.....
9780	2038	Binder Guide (lower) Stud for 26696....
9804	2019	Reciprocating Spring Presser Blade Spring for 20253.....
10135	2061	Separating Blade Arm Latch Lever Spring for 35280.....
10141	2014	Bobbin Winder Tension Spring for 27308
10165	2633	Box Plaiter Centre Guide Stop Pin for 28344.....
10236	774	Driving Attachment Driving Friction Pulley Centre Bearing for 16594.....

## NUMERICAL LIST OF PARTS

NO.	PLATE	NAME
10856	5760	Table Belt Guide (upper) complete for 31-42 Machine when operated head on, Nos. 10857 to 10859 and three wood screws 1¼ in. No. 12 R. H. B.....
		Nos. 10857 to 10859 FOR 10856
10857	5760	Table Belt Guide (upper) Bracket with 448c.....
10858	5757	Table Belt Guide (upper) Pulley Shaft...
10859	5760	" " " " Pulley.....
10875	5841	Wrench for 46660 for 25284.....
*11104	—	Arm Shaft Bushing (front).....
11119	773	" Oil Tube with 52045, for oiling 12165, 12408, 16569, 19365 and 24207.....
11167	767	Lifting Presser Bar Spring (light) .051 wire, for 31-19 Machine.....
11167	767	Presser Bar Spring (light) .051 wire, for 31-15, 31-16, 31-20, 31-22, 31-24, 31-27, 31-32, 31-34, 31-35 and 31-37 Machines
11170	771	Lifting Presser Bar Spring Washer for 31-19 Machine.....
11170	771	Presser Bar Spring Washer for 31-15, 31-16, 31-20, 31-22, 31-24, 31-27, 31-32, 31-34, 31-35, 31-37 and 31-42 Machines.....
11204	770	Thread Take-up Lever Link Hinge Pin for 43990, 43991 and 44179.....
11241	2003	Arm Spool Pin Washer (cloth).....
11241	2003	Bobbin Winder Spool Washer (cloth) for 27308.....
11656	8631	Tape Reel Arm Steady Pin for 120535...
11742	5741	Starting Treadle Pitman Washer for 43816
11833	6255	Knife Grinder Knife Position Pin (upper) for 27681 and 27682.....
12130	5741	Thread Take-up Crank for 44179.....
12131	5739	Needle Bar Connecting Stud with 155c, for 44008.....
12139	2004	Lifting Presser Bar Spring (medium) .055 wire, for 31-19 Machine.....
12139	2004	Presser Bar Spring (medium) .055 wire, for 31-15, 31-16, 31-20, 31-22, 31-24, 31-27, 31-32, 31-34, 31-35 and 31-37 Machines.....
12142	780	Presser Foot for 12370, 20352 and 43979
12143	780	" " " 12369, 12457, 20106, 20349 and 26377.....

NO.	PLATE	NAME
12144	780	Presser Foot for 12372, 12437, 12455, 12468, 12481, 20002, 20117, 20138, 20147, 20151, 20158, 20162, 20304, 20336 and 20471.....
12149	2014	Tension Thread Guard for 31-19, 31-35, 31-39 and 31-42 Machines.....
12150	773	Face Plate Thread Guard (lower) 44181 with 12152, for 12367, 16559, 19355 and 20058.....
12152	1375	Edge Guide Slide Spring Cover Rivet for 36760.....
12152	773	Face Plate Thread Guard (lower) Rivet for 12150.....
12152	1376	Hemmer Slide Spring Cover Rivet for 28682.....
12164	—	Thread Take-up Lever complete for 44179, Nos. 12165 to 12167.....
12165	5741	Thread Take-up Lever for 12164.....
12166	773	“ “ Hinge Pin for 12164 and 12410.....
12167	5741	Thread Take-up Lever Link for 12164...
12168	2003	Bobbin Winder Bracket for 12172, 12202, 12337, 20309 and 20498.....
12169	2003	Bobbin Winder Frame for 12171 and 12201
12170	773	“ “ Spring for 12172, 12202, 12337, 16522, 19260, 20309 and 20498..
12171	2003	Bobbin Winder Frame complete for 12172, Nos. 333D, 5960, 5961, 5963, 12169 and 15077.....
12172	—	Bobbin Winder complete for 4370, Nos. 32D, 180F, 12168, 12170 and 12171.....
12178	774	Driving Attachment Driving Arm Friction Plug (wood) for 16522 and 19260..
12188	768	Oil Cover for 12478 and 20141, obsolete..
12193	2004	Arm Side Cover.....
12196	5739	Needle Bar Connecting Link with 794E, for 44008.....
12197	2001	Feed Cam and Feed Lifting Eccentric with 446c, for 44124.....
12200	774	Feed Lifting Rock Shaft Crank (back) with 462c, obsolete, use 3043.....
12201	2003	Bobbin Winder Frame complete for 12202, Nos. 333D, 5960, 5961, 5963, 12169 and 15077.....
12202	—	Bobbin Winder complete for 2135 and 2862, Nos. 32D, 180F, 12168, 12170 and 12201

NO.	PLATE	NAME
*12204	—	Feed Lifting Rock Shaft Crank Connecting Rod Cap for 12430, obsolete.....
12225	768	Driving Arm Pitman Crank for 12476, for 12478 and 20141, obsolete.....
12237	766	Lifting Lever with 448c, for 12445, 20008, 20256, 20290, 20466 and 43933.....
12240	772	Lifting Lever Pin for 12445, 20008, 20256, 20290, 20466 and 43933.....
12240	772	Presser Bar Lifting Lever Pin for 31-42 Machine.....
12241	772	Lifting Lever Link for 12445, 20008, 20256, 20290, 20466, 43929, 43930, 43933 and 43934.....
12241	772	Presser Bar Lifting Lever Link for 31-42 Machine.....
12242	819	Rock Shaft Hanger with two wood screws 1 in. No. 10, for 4880.....
12243	819	Rock Shaft Lifting Bracket Hook for 4880 and 5598.....
12248	8632	Machine Rest with 27130 and two wood screws 1 in. No. 12, for 79758.....
12250	—	Rock Shaft complete for 12445, 20256, 20341 and 43930, Nos. 2763, 2768, 2778, 6337 and two each 2770 and 7539.....
12258	1308	Presser Foot (wide) for 12369, 12457, 20106 and 20349.....
12259	780	Presser Foot for 12425, 12481, 19474 and 20119.....
12260	780	Presser Foot for 12437, 12450, 20147 and 20348.....
12261	1308	Presser Foot for 12481 and 43978.....
12281	5760	Starting Treadle Pitman Rod for 12439
12283	5741	“ “ “ “ (lower) Joint for 43814.....
12283	5741	Starting Treadle Pitman Rod Joint (treadle) for 12439.....
12284	5738	Presser Bar Lifting Lever with 448c, for 31-42 Machine.....
12285	—	Presser Bar Lifting Lever Lifter for 12286
12286	5739	Presser Bar Lifting Lever Lifter complete for 31-42 Machine, Nos. 775E, 1976 and 12285.....
12287	5757	Presser Bar Spring (light) .0345 wire, for 31-42 Machine.....
12298	—	Throat Plate, large needle hole, for 31-39 and 31-42 Machines.....

## NUMERICAL LIST OF PARTS

NO.	PLATE	NAME
12311	5837	Presser Foot, for shirt work, for 31-15 and 31-20 Machines.....
12312	2049	Starting Bell Crank Bracket with 443c, for 12344.....
12313	2049	Driving Pulley for 31-42 Machine.....
12314	5739	" " Spring for 31-42 Machine.
12316	5738	" " Friction Ring (leather) for 43807 and 43943.....
12317	5741	Starting Treadle Pitman Rod (upper) Joint for 43814.....
12317	5741	Starting Treadle Pitman Rod Joint (connecting stud) for 12439.....
Nos. 12318 TO 12320 FOR 12343		
12318	—	Starting Bell Crank.....
12319	5740	" " " Pitman Stud.....
12320	5740	" " " Stop Pin.....
12321	2049	Stop Pawl for 12344, obsolete, use 44230
12322	5740	" " Hinge Pin for 12344.....
12323	5740	Feed Regulator Handle Friction Spring for 31-32 Machine.....
12323	5740	Stop Pawl Spring for 12344.....
12325	5738	" Wheel Block for 43807, obsolete....
12326	770	Presser Bar Guide Bracket with 453c, for 31-35 and 31-42 Machines.....
12327	770	Lifting Presser Bar Lifting and Releasing Lever Bracket for 31-19 Machine.....
12327	770	Presser Bar Lifting and Releasing Lever Bracket for 31-15, 31-16, 31-20, 31-22, 31-24, 31-27, 31-32, 31-34, 31-35, 31-37 and 31-42 Machines.....
12329	772	Tension Releasing Lever Spring for 31-15, 31-16, 31-19, 31-20, 31-22, 31-24, 31-27, 31-32, 31-34, 31-35, 31-37, 31-39 and 31-42 Machines.....
12331	5757	Feed Forked Connection for 31-32 Machine, obsolete, use 44003.....
12332	5740	Feed Regulator and Reverser for 43992..
12333	5740	" " Handle for 31-32 Machine
12335	1308	Presser Foot (narrow) for 12369, 12457, 20106 and 20349.....
12336	2003	Bobbin Winder Spindle, for spool, for 43982 and 43983.....
12337	—	Bobbin Winder (Hamburg) complete for 2135 and 2862, Nos. 32D, 180F, 12168, 12170 and 43982.....

## NUMERICAL LIST OF PARTS

NO.	PLATE	NAME
12343	5738	Starting Bell Crank complete for 12344, Nos. 12318 to 12320.....
12344	—	Starting Bell Crank Bracket complete, for 31-42 Machine, Nos. 16c, 1513J, 1517J, 1885, 2018, 12312, 12322, 12323, 12343, 25350 and 44230.....
12345	5739	Driving Pulley Friction Ring Stop Pin for 43807 and 43943.....
12348	5837	Presser Foot, for outside stays and strips, for 31-15 and 31-20 Machines.....
12354	772	Tension Releaser, obsolete, use 20037....
*12355	—	Arm with 11104, for 31-15, 31-16, 31-20, 31-22 and 31-34 Machines.....
12357	767	Arm Shaft Flanged Bushing (back) for 31-15, 31-16, 31-19, 31-20, 31-22, 31-24, 31-27, 31-32, 31-34, 31-35, 31-37 and 31-39 Machines.....
12358	2000	Balance Wheel (power) light rim, 2 $\frac{3}{8}$ in. pulley, with two 448c, for 31-15, 31-16, 31-19, 31-20, 31-22, 31-24, 31-27, 31-32, 31-34, 31-35 and 31-39 Machines.....
*12360	—	Bed for 31-15, 31-16, 31-19, 31-20, 31-22, 31-27, 31-32, 31-34, 31-35, 31-39 and 31-42 Machines.....
12361	772	Machine Hinge Connection for 44140 and 44180.....
12365	2001	Crank Connecting Rod with 14013 and two 896E, for 375, obsolete.....
12366	—	Face Plate for 12367.....
12367	2000	Face Plate complete for 31-39 and 31-42 Machines, Nos. 2827, 12150 and 12366
12368	767	Feed Bar for 31-15, 31-16, 31-19, 31-20, 31-22, 31-24, 31-27, 31-32, 31-35 and 31-37 Machines.....
12369	776	Feed Dog, for cloth, 12 teeth (12 teeth to the inch) for 31-15, 31-19, 31-20 and 31-22 Machines, 28654, 28657 and 36293, obsolete.....
12370	2692	Feed Dog, for cloth, 15 teeth (16 teeth to the inch) for 31-15, 31-19, 31-20 and 31-22 Machines, 26466 and 28776.....
12371	779	Feed Dog, for shirt work, for 31-15 Machine, obsolete.....
12372	778	Feed Dog, 13 teeth (12 teeth to the inch) beveled for hemmer, for 31-15 Machine and 26328.....

## NUMERICAL LIST OF PARTS

NO.	PLATE	NAME
12374	766	Feed Lifting Rock Shaft for 12375, obsolete.....
12375	—	Feed Lifting Rock Shaft complete for 31-15, 31-16, 31-19, 31-20, 31-22, 31-24, 31-27, 31-32, 31-34, 31-35 and 31-37 Machines, Nos. 3043, 12374 and 12376, obsolete, use 44126.....
12376	770	Feed Lifting Rock Shaft Crank with 157J and 1813, for 12375 and 44126.....
12379	766	Feed Rock Shaft for 12380 and 20333.....
12380	—	Feed Rock Shaft complete, Nos. 3043 and 12379, obsolete, use 20333.....
12381	767	Needle Bar (hollow) for 31-15, 31-16, 31-19, 31-20, 31-27, 31-32, 31-34, 31-37, 31-39 and 31-42 Machines.....
12382	770	Needle Bar Connecting Link with 794E, for 43997.....
*12383	—	Needle Bar Connecting Stud for 12384 and 20368.....
12384	770	Needle Bar Connecting Stud complete for 43997, Nos. 453c, 1904 and 12383.....
12385	767	Needle Bar Crank with 855c and 858c, obsolete, use 20188.....
12386	767	Oscillating Rock Shaft for 375 and 12387, obsolete.....
12387	—	Oscillating Rock Shaft complete, Nos. 4784, 12386 and 12388, obsolete.....
12388	767	Oscillating Rock Shaft Hinge Pin for 12387, 12498 and 24105.....
12389	766	Oscillating Shaft.....
12390	771	Oscillating Shaft Crank complete, Nos. 457c, 1518E, 1902 and 19496, obsolete..
12391	767	Lifting Presser Bar (hollow) for 31-19 Machine.....
12391	767	Presser Bar (hollow) for 31-15, 31-16, 31-20, 31-22, 31-24, 31-27, 31-32, 31-34, 31-35, 31-37 and 31-42 Machines.....
12392	—	Shuttle, 1 $\frac{1}{8}$ in. diam., Nos. 2996, 12393 and 12417, obsolete, use 19292.....
12393	771	Shuttle Body for 12392 and 19292.....
*12394	—	“ Driver for 12444.....
12395	—	“ Race Slide for 12396, obsolete, use 12431.....
12396	—	Shuttle Race Slide complete, Nos. 4307, 12395 and two 240b, obsolete, use 12432
12397	772	Tension Releasing Lever for 31-19 and 31-42 Machines, obsolete.....

## NUMERICAL LIST OF PARTS

NO.	PLATE	NAME
12398	773	Tension Releasing Lever Hinge Pin for 31-15, 31-16, 31-19, 31-20, 31-22, 31-24, 31-27, 31-32, 31-34, 31-35, 31-37, 31-39 and 31-42 Machines.....
12399	—	Thread Retainer complete for 31-15, 31-16, 31-19, 31-20, 31-22, 31-24, 31-27, 31-32, 31-34, 31-35, 31-37 and 31-39 Machines, Nos. 12400 to 12402, obsolete use, 52379
		Nos. 12400 to 12402 FOR 12399, OBSOLETE
12400	773	Thread Retainer Sleeve.....
12401	773	“ “ Spring.....
12402	773	“ “ Stud.....
12403	772	Arm Spool Pin and Thread Eyelet.....
12404	770	Thread Take-up Crank for 43990.....
12405	8633	Machine Cushion (felt) for 79758.....
12405	774	“ Rest, felt (Attachments and Accessories).....
12408	770	Thread Take-up Lever for 12410.....
12409	770	“ “ “ Link for 12410... ..
12410	—	Thread Take-up Lever complete for 43990 and 43991, Nos. 12166, 12408 and 12409
12411	776	Throat Plate, large needle hole, for 12369, 12457 and 20303, obsolete.....
12412	778	Throat Plate, large needle hole, for 12370 and 43979.....
12413	779	Throat Plate, large needle hole, for 12371, obsolete.....
12414	—	Throat Plate, large needle hole, for 12372, 20002 and 20304.....
12415	768	Lifting Lever Connecting Rod for 12445, 20008, 20341, 20466, 43928 to 43931 and 43934.....
12416	774	Lifting Lever Connecting Rod Joint (Foot and Knee Lifters) for 12445, 20008, 20256, 20290, 20341, 20466, 43928 to 43931, 43933 and 43934.....
12417	—	Shuttle Bobbin Case complete for 12392, Nos. 591F, 592E, 2523, 2526, 2975, 7553 and 15003, obsolete, use 19293.....
12422	5743	Throat Plate, small needle hole, for 31-39 and 31-42 Machines.....
12424	773	Oscillating Shaft Crank Slide Block Cap Screw Washer for 19449.....
12424	773	Reciprocating Spring Presser Regulator Crank Roller Cap Screw Washer for 1942.....

NO.	PLATE	NAME
12425	779	Feed Dog, for cloth, 13 teeth (16 teeth to the inch) for 31-15 and 31-20 Machines and 26250.....
12426	779	Throat Plate, large needle hole, for 12425
12427	766	Arm Shaft for 44121, 44122, 44123, 44124, 44172 and 44217.....
12428	767	Feed and Feed Lifting Eccentric with 446c, for 44217 and obsolete for 31-15, 31-16, 31-20, 31-22 and 31-24 Machines.....
12429	2002	Feed Forked Connection for 31-15, 31-16, 31-20, 31-22 and 31-24 Machines, obsolete.....
12430	2002	Feed Lifting Rock Shaft Crank Connecting Rod with 12204 and two 966e, for 31-15, 31-16, 31-19, 31-20, 31-22, 31-24, 31-27, 31-32, 31-34, 31-35, and 31-37 Machines, obsolete.....
12431	—	Shuttle Race Slide for 12432.....
12432	2004	Shuttle Race Slide complete for 31-15, 31-16, 31-19, 31-20, 31-22, 31-24, 31-27, 31-32, 31-34, 31-35, 31-39 and 31-42 Machines, Nos. 4307, 12431 and two 725e.....
12435	780	Presser Foot with 228d, for 25967 and 26279 to 26283.....
12437	777	Feed Dog, 12 teeth (14 teeth to the inch) four teeth at right of needle (square corner) for 31-15 Machine.....
12438	776	Throat Plate, large oblong needle hole, for 20329, obsolete.....
12439	—	Starting Treadle Pitman complete for 31-42 Machine, Nos. 12283, 12317, 43813 and two 12281.....
12440	777	Throat Plate, small needle hole, for 12437
12441	—	“ “ “ “ “ “ “ “ 12371, obsolete.....
12442	778	Throat Plate, small needle hole, for 12372, 20002, 20304 and 26328.....
12443	772	Oscillating Rock Shaft Oil Pad for 16508, obsolete.....
12444	771	Shuttle Driver 12394 with two 1266c, for 31-15, 31-16, 31-19, 31-27, 31-32, 31-34, 31-35, 31-37, 31-39 and 31-42 Machines

NO.	PLATE	NAME
12445	—	Knee Lifter complete (power table or stand 25265) for 31-15, 31-16, 31-20, 31-22, 31-27, 31-32 and 31-34 Machines, Nos. 76b, 766d, 802d, 1521e, 5598, 12237, 12240, 12241, 12250, 12415, 12416 and two 178e.....
12449	—	Throat Plate, small needle hole, for 12369, 12457 and 20303, obsolete.....
12450	777	Feed Dog, for cloth, 11 teeth (18 teeth to the inch) for 31-15 and 31-20 Machines, 26655, 28342 and 35175.....
12451	2689	Throat Plate, small needle hole, for 12450 and 20348.....
12453	773	Arm Oil Tube for intermediate bearing..
12454	773	“ “ “ with 52045, for oiling 12167 and 12409.....
12455	779	Feed Dog, 13 teeth (14 teeth to the inch) beveled for hemmer, for shirt work, for 31-15 Machine.....
12456	779	Throat Plate, small needle hole, for 12455
12457	2699	Feed Dog, for cloth, 16 teeth (16 teeth to the inch) for 31-15, 31-19, 31-20 and 31-22 Machines, 26760, 28654, 28657 and 35245, obsolete.....
12458	818	Drip Pan with four 1 in. wire nails, for Drop Feed Machines.....
12459	773	Oscillating Rock Shaft Hinge Pin Oil Hole Stop Screw Washer (leather) obsolete..
12464	777	Throat Plate, large needle hole, for 12450 and 20348.....
12465	—	Throat Plate, large needle hole, for 12437
12466	—	“ “ small needle hole, for 12425
12467	781	Presser Foot, for umbrella work, for 31-15 and 31-20 Machines.....
12468	777	Feed Dog, 16 teeth (16 teeth to the inch) beveled for hemmer, for shirt work, for 31-15 Machine.....
12469	—	Throat Plate, large needle hole, for 12468 and 20471.....
12470	777	Throat Plate, small needle hole, for 12468 and 20471.....
12474	1308	Presser Foot for 12372, 12481, 20002, 20138 and 20162.....
12475	818	Driving Attachment Driving Arm Pitman for 12478 and 20141.....
12476	774	Driving Arm Pitman Crank Spring for 12225 for 12478 and 20141, obsolete...

NO.	PLATE	NAME
12477	768	Driving Attachment Starting Crank Shaft for 44176.....
12478	—	Driving Attachment with Bobbin Winder and Treadle complete for 31-15, 31-16, 31-19, 31-27, 31-32, 31-34, 31-35 and 31-39 Machines, Nos. 210D, 692D, 12475, 16522, 16592, 16594, 20372, 24355, 27072, 27308, 44176, 126213 and two 65D
12479	768	Driving Attachment Starting Crank for 44176.....
12480	767	Arm Side Cap for 31-15, 31-16, 31-20, 31-22, 31-24, 31-27, 31-32, 31-34, 31-37 and 31-39 Machines.....
12481	778	Feed Dog for shirt work, 18 teeth (16 teeth to the inch) for 31-15, 31-16 and 31-20 Machines.....
12482	—	Throat Plate, large needle hole, for 12481 and 43978.....
12483	778	Throat Plate, small needle hole, for 12481 and 43978.....
12484	2003	Bobbin Winder Spring for 12172, 12202 and 12337, obsolete.....
12486	—	Oil Cup Packing (felt) for 24024, obsolete
12487	—	Shuttle, 1 $\frac{11}{16}$ in. diam., Nos. 2996, 12488 and 62740 for 31-16 Machine.....
12488	2013	Shuttle Body for 12487.....
12489	—	Shuttle Race (sectional) complete for 31-16 Machine, Nos. 648D, 2531, 2533, 12490 to 12494 and two each 85D, 662D and 2532, obsolete, use 20005.....
12490	—	Shuttle Race Body for 12489, obsolete..
12491	2005	“ “ Cap for 12489, obsolete....
Nos. 12492 TO 12494 FOR 12489 AND 20005		
12492	2005	Shuttle Race Ring.....
12493	2005	“ “ “ Clamp (left).....
12494	2005	“ “ “ “ (right).....
12495	2014	Needle Bar Plug Screw Rivet, obsolete...
12496	2001	Crank Connecting Rod with 14013 and two 896E, for 908, obsolete, use 20197
12497	2001	Oscillating Rock Shaft for 908 and 1902 for 12498, obsolete, use 24104.....
12498	—	Oscillating Rock Shaft complete, Nos. 4784, 12388 and 12497, obsolete, use 24105.....
14010	1206	Bed Frame Hinge Plate Rivet for 20067..

NO.	PLATE	NAME
*14013	—	Crank Connecting Rod Cap for 12365 and 12496, obsolete.....
14017	5736	Finger Protector Screw Washer for 31-39 Machine.....
14026	2061	Separating Blade Holder Stop Pin for 32280
14081	818	Driving Attachment Treadle Pitman Rod (upper) for 14233.....
Nos. 14229 TO 14231 FOR 14232		
14229	5760	Table Belt Guide (lower) Bracket with 448c.....
14230	5760	Table Belt Guide (lower) Pulley.....
14231	5757	“ “ “ “ “ Shaft with 858c.....
14232	5760	Table Belt Guide (lower) complete for 31-42 Machine, when operated head on, Nos. 14229 to 14231 and four wood screws 1 $\frac{1}{4}$ in. No. 10 R. H. B.....
14233	818	Driving Attachment Treadle Pitman complete, for 14234 and 126213, Nos. 2762, 6055, 14081, 27637, 27638 and two 9079
14234	—	Driving Attachment Treadle and Pitman complete for 12478 and 20141, Nos. 14233 and 27642, obsolete.....
15003	771	Shuttle Bobbin Case Hinge, Nos. 2972 to 2974, for 12417 and 19293, obsolete....
15072	2014	Bobbin Winder Position Pin for 15077 and 27538.....
15072	1388	Presser Foot Guide Hinge Pin for 28773
15072	2658	“ “ Knife Clamp Steady Pin for 28967.....
15077	773	Bobbin Winder Spindle with 15072, for 12171, 12201, 16515, 20308, 43982 and 43983.....
15098	771	Shuttle Tension Spring for 19293 and 24074, obsolete.....
15130	818	Driving Attachment Treadle Pitman complete for 15131, Nos. 2762, 2877, 6055, 9079, 27637 and 27638, obsolete.....
15131	—	Driving Attachment Treadle and Pitman complete for 12478 and 20141, Nos. 15130 and 27642, obsolete, use 126042.....
15132	773	Driving Attachment Driving Arm Brake Rivet for 16518.....
15140	2013	Shuttle Bobbin Case Latch for 15141....
15141	—	“ “ “ Hinge for 24074 and 62740, Nos. 2973, 2974 and 15140.....

NO.	PLATE	NAME
15278	771	Shuttle Tension Spring for 62740.....
16128	5735	Rock Shaft Hanger (front) with two wood screws 1 in. No. 10, for 20465.....
16508	772	Oscillating Rock Shaft Oil Pad Holder with 12443, obsolete.....
16514	768	Bobbin Winder Frame for 16515.....
16515	768	Bobbin Winder Frame complete for 16522 and 19260, Nos. 333D, 5960, 5961, 5963, 15077 and 16514.....
16516	774	Bobbin Winder Stop Latch with 152F and 1550H, for 16522.....
16518	818	Driving Attachment Driving Arm with 2269, 2928 and two 15132, for 16522 and 19260.....
16522	—	Driving Attachment Driving Arm complete for 12478, Nos. 32D, 75D, 180F, 427E, 693D, 1508C, 1579C, 12170, 12178, 16515, 16516, 16518, 16530 and 27303.....
16524	—	Driving Attachment Balance Wheel Friction Ring (leather) for 16592.....
16530	818	Driving Attachment Bracket for 16522 and 19260.....
16555	1206	Bed Frame Hinge Plate for 20067.....
16558	—	Face Plate for 16559.....
16559	5735	Face Plate complete for 31-35 Machine, Nos. 2827, 12150 and 16558.....
16563	5738	Knife Bar Driving Crank (forked) for 24433.....
16564	5738	Knife Bar Driving Crank Bracket for 24433
16568	5841	Needle Bar with 620F, 1904F and 24391, for 31-35 Machine.....
16569	5738	Needle Bar Crank (eccentric) with 448C and 743C, for 44123.....
16573	2039	Roller Arm for 19394.....
16586	5843	Lifting Lever Pin for 43929, 43930 and 43934.....
16592	818	Driving Attachment Balance Wheel (friction) with 7958, 16524 and two 435C, for 12478 and 20141.....
16594	818	Driving Attachment Driving Friction Pulley, $2\frac{5}{16}$ in. diam., with 861D and 10236, for 12478 and 20141.....
18055	2038	Presser Foot Hinge Pin for 28691.....
19103	1271	Feed Dog, 12 teeth (16 teeth to the inch) for 31-35 Machine.....
19131	2012	Shuttle Bobbin for 20590, 20655 and 20758
19219	1206	Bed Frame Cushion (leather) for 20067..

NO.	PLATE	NAME
19220	1206	Bed Frame Cushion Spring for 20067....
19221	2045	Wrench for 936, 1516 and 1619 (Attachments and Accessories).....
19223	—	Presser Foot Shank for 20311 and 24489..
19226	1206	Bed Frame Hinge Connection for 19398..
19229	2004	Needle Bar (hollow) for high lift, for 31-22 and 31-24 Machines.....
19258	2009	Bobbin Winder Stop Latch with 152F and 1550H, for 19260.....
19260	—	Driving Attachment Driving Arm complete for 20141, Nos. 32D, 75D, 180F, 427E, 693D, 1508C, 1579C, 12170, 12178, 16515, 16518, 16530, 19258 and 27303
19292	771	Shuttle, $1\frac{1}{8}$ in. diam., Nos. 2996, 12393 and 62740, for 31-15, 31-19, 31-27, 31-32, 31-34, 31-35, 31-37, 31-39 and 31-42 Machines.....
19293	771	Shuttle Bobbin Case complete for 19292, Nos. 591F, 592E, 2523, 2975, 7553, 15003 and 15098, obsolete, use 24074.....
19297	5738	Knife Bar with 2301, for 24128.....
19334	—	Presser Foot Plate for 19336.....
19335	—	“ “ “ Shank for 19336, 20359 and 120144.....
19336	1308	Presser Foot (hinged) complete, for 12370, 20355, 43979 and 44136, Nos. 7298, 19334 and 19335.....
19354	—	Face Plate for 19355.....
19355	5735	Face Plate complete for 31-19 Machine, Nos. 2827, 12150 and 19354.....
19356	1312	Lifting Presser Bar Bell Crank for 24716
19357	1312	“ “ “ “ “ Connecting Link for 24716.....
		Nos. 19358 to 19360 FOR 19361
19358	1312	Lifting Presser Bar Bell Crank Driving Arm.....
19359	1312	Lifting Presser Bar Bell Crank Driving Arm Shaft.....
19360	767	Lifting Presser Bar Bell Crank Driving Arm Shaft Bracket.....
19361	—	Lifting Presser Bar Bell Crank Driving Arm Shaft Bracket complete for 31-19 Machine, Nos. 2049 and 19358 to 19360.....
19362	1313	Lifting Presser Bar Bell Crank Driving Arm Eccentric Connection for 62637...

## NUMERICAL LIST OF PARTS

NO.	PLATE	NAME
19363	1312	Lifting Presser Bar Guide Bracket with 453c, for 31-19 Machine, obsolete.....
19364	1312	Lifting Presser Foot for 19370.....
19365	767	Needle Bar Crank and Lifting Eccentric with 448c and 743c, for 62637.....
19366	1313	Vibrating Presser Bar for 24716.....
Nos. 19367 to 19369 FOR 31-19 MACHINE		
19367	1313	Vibrating Presser Bar Cap.....
19368	1313	" " Cushion (rawhide).....
19369	1313	" " Spring.....
19370	1312	" " Foot for 12370 and 43979.....
19372	1313	Lifting Lever Pin for 20341, 43928 and 43931.....
19374	1313	Vibrating Presser Foot for 12369 and 12457.....
19375	1313	Lifting Presser Foot for 19374 and 19376.....
19376	1313	Vibrating Presser Foot for 20106, for 31-19 Machine and for 24344 for 26956.....
19391	1321	Knife Holder with 620F, 2291 and two 223F, for 24128.....
19392	1271	Presser Foot, for $\frac{3}{16}$ in. gauge and above, for 31-35 Machine.....
19394	—	Roller Presser complete, $\frac{1}{4}$ in. fine roller, for 26150, Nos. 1928 and 16573.....
19397	1206	Bed Frame Hinge Connection Cap for 19398.....
19398	—	Bed Frame Hinge Connection 19226 with 211E and 19397, for 20067.....
19402	—	Shuttle Race Body for 19404, obsolete....
19403	2006	" " Cap for 19404, obsolete.....
19404	1356	Shuttle Race complete for 31-20 Machine, Nos. 648D, 662D, 2419, 2533, 4621, 19402, 19403 and two 2532, obsolete, use 24325.....
19405	—	Throat Plate, small needle hole, for 20117.....
19406	2012	Shuttle Driver with two 1266c, for 31-20, 31-22 and 31-24 Machines.....
19409	—	Throat Plate, large needle hole, for 20138 and 20162.....
19410	1263	Throat Plate, small needle hole, for 20138 and 20162.....
19412	1260	Throat Plate, large needle hole, for 20147 and 44177.....
19413	—	Throat Plate, small needle hole, for 20147 and 44177.....
19415	1262	Throat Plate, large needle hole, for 20151 and 44144.....

## NUMERICAL LIST OF PARTS

NO.	PLATE	NAME
Nos. 25657 to 25663 FOR 25664		
25657	1949	Binder Bed with 656E and three 447F....
25658	1949	" Guide (centre, large) with 589E..
25659	1949	" " (centre, small) with 589E..
25660	1949	" " (lower).....
25661	1949	" " (upper).....
25662	1949	" Binding Guide.....
25663	1949	Presser Foot.....
25664	1949	Binder (adjustable) complete, for general work, Nos. 207F, 233D, 1566D, 1571D, 7071, 25657 to 25663 and two 8975....
25669	—	Binder Folder Slide with 25670 and 25671, for 36457.....
25670	2038	Binder Folder Slide Block for 25669.....
25671	2038	" " " " Rivet for 25669.....
25672	6254	" " " Carrier with 656E, for 36463.....
25673	6254	Binder Folder Slide Carrier Adjusting Thumb Nut Guide for 36463.....
25677	6254	Binder Pressure Spring for 36463.....
25698	2024	" Folder for 26694.....
25703	2024	" Pressure Spring with 26698, for 26694.....
25705	—	Binder on Shank, for $\frac{3}{8}$ in. tape.....
25706	—	" " " " $\frac{1}{4}$ in. tape.....
25707	2605	" " " " $\frac{1}{2}$ in. tape.....
25708	—	" " " " $\frac{3}{8}$ in. tape.....
25709	—	" " " " $\frac{5}{8}$ in. tape.....
25710	—	" " " " $\frac{1}{2}$ in. tape.....
25711	—	" " " " $\frac{3}{4}$ in. tape.....
25712	—	" " " " $\frac{1}{2}$ in. tape.....
25713	—	" " " " $\frac{3}{8}$ in. tape.....
25714	—	" " " " $\frac{1}{2}$ in. tape.....
25715	—	" " " " 1 in. tape.....
25721	2021	" Folder for 26250, 26466, 28657 and 28784.....
25722	2021	Binder Ribbon Tension complete for 26250, 26466, 28657 and 28784, Nos. 26614, 26616 and four 26615, 120437 and 120459.....
25733	2022	Binder Folder, for $\frac{1}{2}$ in. binding, for 26402.....
25734	2022	Binder Ribbon Tension complete for 26402, Nos. 26617, 26618 and seven 26486....
25744	1314	Binder Folder and Ribbon Tension with nine 26486, for $\frac{1}{2}$ in. binding, for 26701.....
25745	—	Binder Folder and Ribbon Tension with nine 26486, for $\frac{1}{4}$ in. binding, for 26701.....



## NUMERICAL LIST OF PARTS

NO.	PLATE	NAME
25788	2026	Corder Arm with 25789, for 25792.....
25789	2026	“ “ Tip for 25788.....
25789	2027	“ Bow Tip for 26649 and 26938....
25790	2026	“ Arm Hinge Pin for 25792.....
25791	2026	“ “ Bracket for 25792.....
25792	2026	Corder Armand Bracket complete for 26169, 26328, and 28788, Nos. 190D, 879D, 25788, 25790, and 25791.....
25855	2038	Binder Folder Guide (lower) Screw Stud for 25646.....
25866	2045	Guide, for flush throat plate.....
25873	2045	“ (combination).....
25874	2045	“ for raised throat plate.....
25888	2028	Hemmer Tongue.....
Nos. 25919 TO 25921 FOR 12372, 12455, 20002, 20117 AND 20151		
25919	—	Hemmer (foot) $\frac{5}{8}$ in. hem.....
25920	2028	“ “ $\frac{1}{2}$ in. hem.....
25921	—	“ “ long, $\frac{1}{8}$ in. hem, for shirts
Nos. 25922 TO 25924 FOR 12369 AND 12457		
25922	2028	Hemmer (foot) $\frac{1}{8}$ in. hem.....
25923	—	“ “ long, $\frac{3}{8}$ in. hem, for shirts
25924	—	“ “ $\frac{1}{4}$ in. hem.....
25967	1387	Presser Foot Strip Gauge for 12435 and 20157.....
25983	2021	Presser Foot for 26250, 26466 and 28657.
25984	2025	“ “ “ 26328.....
25985	2029	“ “ (single toe) for gathering...
25990	2029	Quilter complete, Nos. 25991 and 25992, obsolete, use 120485.....
25991	2029	Quilter Guide for 25990, obsolete.....
25992	2029	“ “ Holder with two 207F, for 25990 and 28660.....
25993	984	Ruffler Frame with 25994 to 25996 and 26001, for 26230.....
Nos. 25994 TO 25996 FOR 25993		
25994	2014	Ruffler Frame Stud.....
25995	2014	“ “ Block.....
25996	2014	“ “ “ Rivet.....
Nos. 25997 TO 26000 FOR 26230		
25997	984	Ruffler Driving Lever.....
25998	984	“ “ “ Spring.....
25999	984	“ Ruffling Blade.....
26000	984	“ “ “ Lever.....

## NUMERICAL LIST OF PARTS

NO.	PLATE	NAME
26001	2014	Ruffler Ruffling Blade Lever Stop Pin for 25993.....
26002	2014	Ruffler Ruffling Blade Clamp for 26230..
26005	984	“ Driving Lever for 26018.....
26007	984	“ Foot for 26018.....
26010	984	“ Ruffling Blade with 8505, for 26018
26011	984	“ “ “ Lever with 26189 and 26629, for 26018.....
26016	984	Ruffler Frame for 26018.....
26017	984	“ Needle Clamp with 808F, for 26018
26018	984	Ruffler (power) complete, Nos. 69D, 207F, 811D, 812B, 1621E, 1666D, 26005, 26007, 26010, 26011, 26016, 26017 and 35019..
26026	2045	Screw Driver, machine (Attachments and Accessories).....
26080	1383	Throat Plate Needle Hole Plate for 26760 and 28342.....
26092	2671	Presser Foot Graduated Adjustable Guide Clamping Lever Spring Rivet for 28953
26092	2671	Ruffling Separating Blade Rivet for 43920
26092	2038	Tucker Tuck Marking Plate Rivet for 26101.....
Nos. 26099 TO 26101 FOR 26377		
26099	2037	Tucker Bed.....
26100	2037	“ Cloth Guide.....
26101	2037	Tucker Cloth Guide Slide with 26102 and two 26092.....
26102	2037	Tucker Tuck Marking Plate for 26101...
Nos. 26105 TO 26109 FOR 26377		
26105	2037	Tucker Tuck Marking Bar Bracket.....
26106	2038	“ “ “ “ “ Hinge Pin.....
26107	2037	Tucker Tuck Marking Bar Lifting Spring
26108	2037	“ “ “ “ Pressure Spring
26109	2037	“ “ “ “ “ “ Clamp with 196F.....
26111	2037	Tucker Tuck Smoothing Spring for 26377
26138	2039	Welt Guide Carrier Slide Switch Cam with Shaft, for 26150.....
26139	2039	Welt Guide Carrier Slide Switch Cam Shaft Head with Lever with 337D, for 26150.....
26143	2039	Welt Guide Bed for 26150.....
26144	2039	“ “ Cap for 26150.....

Nos. 26145 to 26147 FOR 26148		
NO.	PLATE	NAME
26145	2039	Welt Guide Carrier.....
26146	—	“ “ “ Slide.....
26147	2039	“ “ “ Tongue.....
26148	—	Welt Guide Carrier complete for 26150, Nos. 233D, 26145 to 26147 and 26149..
26149	2039	Welt Guide Width Guide for 26148.....
26150	2039	Welt Guide (adjustable) with Switch com- plete, Nos. 240D, 910F, 26138, 26139, 26143, 26144, 26148, 26344 and three 238D.....
26160	—	Hemmer (foot) plain bottom, $\frac{3}{8}$ in. hem
26161	2028	“ “ “ “ $\frac{1}{8}$ in. hem
26162	—	“ “ “ “ $\frac{3}{16}$ in. hem
26163	—	“ “ “ “ $\frac{1}{4}$ in. hem
26166	2025	Feed Dog, 13 teeth (12 teeth to the inch) for 26169.....
26167	2025	Presser Foot for 26169 and 28788.....
26168	2025	Throat Plate for 26166, for 26169.....
26169	—	Corder complete, for top and bottom cording, Nos. 25792, 26166 to 26168 and two 135D.....
26173	2038	Strip Folder Lock Stud for 28707.....
26174	2038	“ “ “ “ Spring for 28707
26189	2014	Ruffler Ruffling Blade Lever Protector Rivet for 26011.....
26229	984	Ruffler Ruffling Presser Foot for 26230..
26230	984	Ruffler (power) complete, Nos. 69D, 207F, 560B, 1582D, 1603E, 25993, 25997 to 26000, 26002, 26229, 26719 and two 337D.....
26231	2014	Presser Foot Spring for 20346, 24546, 24983 and 28691.....
26249	2021	Throat Plate for 12425 for 26250.....
26250	—	Binder (English) complete, Nos. 190D, 207F, 12425, 25721, 25722, 25983, 26249 and two 7071.....
26276	2038	Presser Foot Hinge Pin for 20359 and 44161.....
Nos. 26279 to 26283 FOR 12435 AND 20157		
26279	—	Presser Foot Extension, $\frac{1}{16}$ in.....
26280	—	“ “ “ $\frac{1}{8}$ in.....
26281	1387	“ “ “ $\frac{1}{4}$ in.....
26282	—	“ “ “ $\frac{3}{8}$ in.....
26283	—	“ “ “ $\frac{1}{2}$ in.....

NO.	PLATE	NAME
26328	—	Corder complete, for top cording, Nos. 12372, 12442, 25792, 25984 and two 135D.....
26344	2039	Welt Guide Carrier Slide Stop for 26150
26361	—	Seamer Edge Guide for 26658.....
26368	2037	Tucker Tuck Marking Bar for 26369.....
26369	—	Tucker Tuck Marking Bar complete for 26377, Nos. 26368 and 26370 to 26372  Nos. 26370 to 26372 FOR 26369
26370	2038	Tucker Tuck Marking Pin.....
26371	2038	“ “ “ “ Guide Pin....
26372	2038	“ “ “ “ Spring.....
26377	2037	Tucker (power) complete, Nos. 220D, 291D 334D, 401E, 12143, 26099 to 26101, 26105 to 26109, 26111, 26369, 26378 and three 4604.....
26378	2037	Tucker Leveling Plate for 26377.....
26400	2022	Presser Foot for 26402.....
26401	2022	Throat Plate for 19474 for 26402.....
26402	—	Binder (English) complete, for cut cloth, Nos. 207F, 19474, 25733, 25734, 26400, 26401, two 190D and three 7071.....
26403	2029	Feller (foot).....
26428	2028	Hemmer (foot) $\frac{1}{8}$ in. hem, for 12437 and 20147.....
26438	2632	Box Plaiter Sliding Bracket Cap for 28352
26439	2038	“ “ “ “ Locking Pin Bushing with 468C, for 28352.....
26459	5306	Hemmer Spring Rivet for 28670.....
26465	2692	Throat Plate, large needle hole, for 12370, for 26466.....
26466	—	Binder (English) complete, Nos. 190D, 207F, 12370, 25721, 25722, 25983, 26465 or 35741 and two 7071.....
26485	2045	Screw Driver, shuttle tension (Attach- ments and Accessories).....
26486	2022	Binder Ribbon Tension Pin (straight) for 25734, 25744, 25745, 26953 and 28337..
26568	2635	Tucker Edge Guide for 26597.....
26569	2635	“ “ “ Slide for 26597.....
26570	2634	“ Tuck Guide Plate for 26683.....
26571	2634	“ “ “ “ Arm with 5944, for 26683.....
26597	—	Tucker Edge Guide complete for 26685, Nos. 287D, 7071, 26568 and 26569.....

NO.	PLATE	NAME
26603	1381	Feed Dog, 20 teeth (16 teeth to the inch) for 28678, 28731, 35226, 35354, 35681, 35855, 35863, 120247, 120248 and 120533
26605	7696	Throat Plate, large needle hole, for 26603 and 120001.....
26606	—	Throat Plate, small needle hole, for 26603 and 120001.....
26607	1387	Presser Foot Body for 26609 to 26611 and 35016.....
26608	1387	Presser Foot Plate (glass) for 26609.....
26609	—	Presser Foot (glass plate) complete, Nos. 26607 and 26608.....
26610	1387	Hemmer, $\frac{1}{8}$ in. hem, for 26607.....
26611	—	" $\frac{3}{16}$ in. hem, for 26607.....
26614	2021	Binder Ribbon Tension Pin (bent) for 25722 and 120123.....
26615	2021	Binder Ribbon Tension Pin (straight) for 25722 and 120123.....
26616	2021	Binder Ribbon Tension Plate for 25722..
26617	2022	" " " Pin (bent) for 25734 and 28337.....
26618	2022	Binder Ribbon Tension Plate for 25734..
26629	2014	Ruffler Ruffling Blade Lever Protector for 26011.....
26638	2029	Presser Foot (double toe) for gathering..
26639	—	" " with 228D, for 26641.....
26640	2029	" " Adjustable Guide for 26641
26641	2029	" " 26639 with Adjustable Guide No. 26640, for tailor work.....
Nos. 26642 to 26645 FOR 26646		
26642	—	Presser Foot.....
26643	2029	" " Guide.....
26644	5843	" " " Hinge Pin.....
26645	5843	" " " Spring.....
26646	2029	Presser Foot (spring guide) complete, Nos. 337D and 36642 to 26645.....
26647	2027	Corder Bow for 26649.....
26648	2027	Presser Foot for 26649 and 26938.....
26649	2027	Corder (bow) complete, for top cording, Nos. 4604, 25789, 26647 and 26648....
26650	2029	Presser Foot, for braiding.....
26651	2032	" " " folding umbrella straps
26652	—	Hemmer, $\frac{3}{8}$ in. hem, for 26655.....
26653	2032	" Shank for 26655, 26660, 26662, 26664, 26666, 26935, 28948, 36521 and 36712.....

NO.	PLATE	NAME
26653	2032	Seamer Shank for 26658.....
26654	2032	Hemmer Rivet for 26655, 26660, 26662, 26664, 26666, 26935, 28948, 36521 and 36712.....
26654	2032	Seamer Rivet for 26658.....
26655	2031	Hemmer on Shank complete, Nos. 26652 to 26654.....
26656	2030	Presser Foot for 26655.....
26657	—	Seamer, for umbrella work, for 26658....
26658	2032	Seamer complete, Nos. 26361, 26653, 26654 and 26657.....
26659	—	Hemmer for 26660.....
26660	2031	Hemmer on Shank complete, $\frac{3}{8}$ in. hem, for umbrella work, Nos. 26653, 26654 and 26659.....
26661	—	Hemmer (wide) for 26662.....
26662	2031	Hemmer on Shank complete, Nos. 26653, 26654 and 26661.....
26663	—	Hemmer for 26664.....
26664	2030	Hemmer on Shank complete, for raw edge silk, Nos. 26653, 26654 and 26663.....
26665	—	Hemmer, $\frac{1}{8}$ in. hem, for 26666.....
26666	2030	Hemmer on Shank complete, Nos. 26653, 26654 and 26665.....
Nos. 26668 to 26671 FOR 26724		
26668	2035	Ruffler Driving Lever Spring.....
26669	2035	" Frame.....
26670	2034	" Guide (left) with 26679 and two 662D.....
26671	2035	Ruffler Guide (right) with 26679 and two 662D.....
26675	2035	Ruffler Ruffling Blade for 26724.....
26676	2035	" " " Clamp for 26724..
26678	2035	" " " Lever Disengaging Lever for 26724.....
26679	2035	Ruffler Separating Blade for 26670 and 26671.....
26681	2039	Presser Foot for 26150.....
26683	—	Tucker Tuck Guide Plate complete for 26685, Nos. 58D, 287D, 732D, 7071, 26570, 26571, 26684 and two wood screws 1 in. No. 12.....
26684	2634	Tucker Tuck Guide Plate Bracket for 26683.....
26685	—	Tucker (long arm) complete, Nos. 939D, 26597, 26683 and 26686....

## NUMERICAL LIST OF PARTS

NO.	PLATE	NAME
26686	8630	Presser Foot for 26685.....
26694	2024	Binder (adjustable) complete, for capfronts, for 31-20 Machine, Nos. 334d, 1566d, 25698, 25703, 26695 to 26697, two 152f and three 7071.....
Nos. 26695 to 26697 FOR 26694		
26695	2024	Binder Bed with 9558.....
26696	2024	" Guide (lower) with 1141d and 9780
26697	2024	" " (upper).....
26698	2024	" Pressure Spring Lifting Button for 25703.....
26699	1314	Feed Dog, 14 teeth (16 teeth to the inch) for 26701.....
26700	1314	Throat Plate with Extension for 26699, for 26701.....
26701	—	Binder (English) complete for 31-19 Machine, Nos. 671d, 25744, 25745, 26699, 26700, 26702 and 26703.....
26702	1314	Lifting Presser Foot for 26701 and 28784
26703	1314	Vibrating Presser Foot for 26701 and 28784
26718	1370	Ruffler Needle Clamp Body for 26719....
26718	1370	Tucker Needle Clamp Body for 26719....
26719	984	Ruffler Needle Clamp complete for 26230, 26724 and 28816, Nos. 1115f, 1943 and 26718.....
26719	984	Tucker Needle Clamp complete for 36561 Nos. 1115f, 1943 and 26718.....
26722	2035	Ruffler Driving Lever for 26724.....
26723	2034	" Ruffling Blade Lever for 26724....
26724	2034	Ruffler (power) complete, with right and left guides, with separating blades and disengaging lever to throw ruffling blade out of action, Nos. 102d, 223d, 812b, 1101c, 1621e, 1640c, 2301, 26668 to 26671, 26675, 26676, 26678, 26719, 26722, 26723 and two 337d.....
26760	1383	Throat Plate with 337d and 26080, for under braiding, for 12369 and 12457....
26795	5839	Corder Cord Guide for 120207.....
26796	5839	" " " Arm with 26798 and three 6037, for 120207.....
26798	5839	Corder Cord Guide Bracket for 26796....
26801	1387	Presser Foot Adjustable Guide for 26802
26802	1387	" " with two adjustable guides, Nos. 26801 and two 725d.....
26803	1375	Edge Guide Bed with 2362, for 26810....

## NUMERICAL LIST OF PARTS

NO.	PLATE	NAME
Nos. 26805 to 26808 FOR 26810		
26805	1375	Edge Guide Slide Cap (left).....
26806	1375	" " " " (right).....
26807	1375	" " " Lever.....
26808	1375	" " " Spring.....
26809	1375	Edge Guide Slide Spring Cover for 36760
26810	1375	Edge Guide (roller) complete, Nos. 94d, 233d, 26803, 26805 to 26808, 36760, two 207f and four 220d.....
26888	1344	Ruffling Arm (lower) for 26890.....
26889	1344	" " (upper) with 190d and 219f, for 26890.....
26890	1344	Ruffling Arm (adjustable) for 28845, Nos. 2291, 26888, 26889 and two 207f.....
26934	—	Hemmer (narrow) for 26935.....
26935	1386	Hemmer on Shank complete, Nos. 26653, 26654 and 26934.....
26936	1387	Presser Foot, for etching.....
26937	1385	Corder Bow for 26938.....
26938	1385	Corder (bow) complete, for top cording, Nos. 4604, 25789, 26648 and 26937....
26948	2601	Edge Folder on Shank, to turn edge of yoke and insert body of shirt.....
*26951	—	Binder Folder (lower) for 26953.....
*26952	—	" " (upper) for 26953.....
Nos. 26953 to 26955 FOR 26956		
26953	1379	Binder Folder with Ribbon Tension complete, Nos. 26951, 26952, two each 193f, 7071 and nine 26486.....
26954	1378	Lifting Presser Foot.....
26955	1378	Throat Plate with Extension, for 24344..
26956	—	Binder (adjustable) complete for 31-19 Machine, Nos. 283d, 19376, 24344 and 26953 to 26955.....
26977	1391	Presser Foot with Graduated Adjustable Guide No. 26978 with 335d, for tailor work.....
26978	1391	Presser Foot Graduated Adjustable Guide for 26977.....
27072	—	Driving Attachment Shaft Driving Pulley (sectional grooved) 12 in. diam., $1\frac{1}{8}$ in. bore, with two 597c, for 12478 and 20141
27130	8633	Machine Cushion (leather) for 12248.....
27302	1162	Bobbin Winder Frame for 27647, 27650, 27651 and 27875.....

NO.	PLATE	NAME
27303	773	Bobbin Winder Frame Spring for 27047, 27650, 27651 and 27875.....
27303	773	Bobbin Winder Stop Latch Spring for 16522 and 19260.....
27306	1162	Bobbin Winder Spool Pin for 27308.....
27307	1162	“ “ “ Stand for 27308....
27308	1162	Bobbin Winder Spool Stand complete for 12478, 20141, 27544, 27554, 27588 and 27876, Nos. 418E, 1562J, 2106, 10141, 11241, 27306, 27307 and two each 2455 and wood screws 1 in. No. 10.....
27312	2003	Bobbin Winder Stop Latch for 27647 and 27650.....
27323	1105	Knife Grinder Holder Guide Bar for 60583
27538	1162	Bobbin Winder Spindle 27849 with 15072, 27850 and 41828, for 27647, 27650, 27651 and 27875.....
27540	2445	Bobbin Winder Base for 27647 and 27875
27541	2445	“ “ Pulley for 27647 and 27875
27544	—	Bobbin Winder (swinging automatic, right hand) complete for 2996, for stand, Nos. 27308 and 27647.....
27552	1162	Bobbin Winder Base for 27650 and 27651
27553	1162	“ “ Pulley for 27650 and 27651
27554	—	Bobbin Winder (swinging automatic, right hand) complete for 2996, for power table, Nos. 27308 and 27650.....
27564	1104	Knife Grinder Frame with 27574, for 60583.....
27565	1104	Knife Grinder Emery Wheel, 2 in. diam., for 60934.....
27567	1105	Knife Grinder Emery Wheel Shaft for 60934.....
27568	1105	Knife Grinder Emery Wheel Shaft Oil Hole Cover (rubber) for 60583.....
27569	1105	Knife Grinder Emery Wheel Shaft Pulley for 60934.....
27572	1104	Knife Grinder Knife Holder Guide Bar Bracket with 27574, for 60583.....
27573	1105	Knife Grinder Knife Holder Guide Bar Bracket Spring for 60583.....
27574	1105	Knife Grinder Knife Holder Guide Bar Bracket Spring Hook for 27564 and 27572.....
27587	1162	Bobbin Winder Stop Latch for 27651 and 27875.....

NO.	PLATE	NAME
27588	—	Bobbin Winder (swinging automatic, right hand) complete for 19131, for power table, Nos. 27308 and 27651.....
27623	2836	Thread Unwinder Spool Pin for 41527 and 41531.....
27636	363	Driving Attachment Treadle for 27642, obsolete.....
27636	363	Starting Treadle for 43815.....
27637	818	Driving Attachment Treadle Pitman Rod (lower) for 14233 and 15130.....
27638	5841	Driving Attachment Treadle Pitman Rod (lower) Spring for 14233 and 15130....
27642	—	Driving Attachment Treadle complete for 14234 and 15131, Nos. 2878, 9082, 27636 and four wood screws 1 in. No. 16, obsolete.....
27647	2445	Bobbin Winder for 27544, Nos. 35D, 1620J, 27302, 27303, 27312, 27538, 27540, 27541, 50356D and two wood screws 1 in. No. 7.....
27650	—	Bobbin Winder for 27554, Nos. 35D, 1620J, 27302, 27303, 27312, 27538, 27552, 27553, 50356D and two wood screws 1 in. No. 7.....
27651	1162	Bobbin Winder for 27588, Nos. 35D, 1620J, 27302, 27303, 27538, 27552, 27553, 27587, 50356D and two wood screws 1 in. No. 7.....
27657	—	Knife Grinder Knife Holder Body for 27658.....
27658	1105	Knife Grinder Knife Holder complete for 5726 and 27661, Nos. 899J, 27657 and 27660.....
27659	1105	Knife Grinder Knife Holder Stop Collar with 237K, for 60583.....
27660	6255	Knife Grinder Knife Position Pin for 27658 and 126393.....
27660	6255	Knife Grinder Knife Position Pin (lower) for 27681 and 27682.....
27661	—	Knife Grinder complete for 5726, Nos. 27662, 60583, either 27658, 27681 or 27682 and three wood screws 1 in. No. 10
27662	1104	Wrench for 1508 and 1516 for 27661.....
27679	—	Knife Grinder Knife Holder Body for 27681.....
27680	—	Knife Grinder Knife Holder Body for 27682, obsolete.....

## NUMERICAL LIST OF PARTS

NO.	PLATE	NAME
27681	6255	Knife Grinder Knife Holder complete for 27661, Nos. 899J, 11833, 27660 and 27679.....
27682	6255	Knife Grinder Knife Holder complete for 27661, Nos. 899J, 11833, 27660 and 27680, obsolete, use 126393.....
27739	8520	Thread Unwinder Thread Cone (wood) for large cones, for 41529 and 41533...
27822	1105	Knife Grinder Emery Wheel Clamping Nut Washer for 60934.....
*27849	—	Bobbin Winder Spindle for 27538.....
*27850	—	“ “ “ Collar for 27538
27875	—	“ “ for 27876, Nos. 35D, 16201, 27302, 27303, 27538, 27540, 27541, 27587, 50356D and two wood screws 1 in. No. 7.....
27876	—	Bobbin Winder (swinging automatic, right hand) complete for 19131, for stand, Nos. 27308 and 27875.....
27940	2836	Thread Unwinder Spool Stand with 453c, for 41529 and 41533.....
28054	5742	Starting Treadle Centre for 20039.....
28084	8633	Machine Cushion (felt) Pin for 79758....
28084	8633	“ Rest Pin (Attachments and Accessories).....
28334	1380	Binder Folder for 28678 and 28776.....
28336	—	“ Ribbon Tension Plate for 28337..
28337	1380	Binder Ribbon Tension complete for 28678 and 28776, Nos. 26617, 28336 and eight 26486.....
28342	1383	Throat Plate with 337D and 26080, for 12450 for under braiding.....
		Nos. 28343 TO 28351 FOR 28352
28343	2632	Box Plaiter Centre Guide.....
28344	2632	“ “ “ “ Holder with 10165.....
28345	2632	Box Plaiter Folder Blade (left).....
28346	2632	“ “ “ “ (right).....
28347	2632	“ “ Sliding Bracket (left).....
28348	2632	“ “ “ “ (right).....
28349	2632	“ “ “ “ Arm (left) with 2301.....
28350	2632	Box Plaiter Sliding Bracket Arm (right) with 2301.....
28351	2632	Box Plaiter Sliding Bracket Arm Extension Bracket.....

## NUMERICAL LIST OF PARTS

NO.	PLATE	NAME
28352	—	Box Plaiter complete, Nos. 28343 to 28351, two each 190D, 200F, 514C, 914F, 1564D, 2296, 2297, 7071, 26438, 26439, four 401E and six 233D.....
28353	2633	Presser Foot with 28354, 28355 and two 665D, for 28352.....
28354	2633	Presser Foot Guide (left) for 28353.....
28355	2633	“ “ “ (right) for 28353.....
28358	2624	Edge Folder (suspended) left hand, to turn edge under, for 31-27 Machine.....
28359	1395	Edge Folder (double) with Separating Blade on Shank, lower folder to turn the edge of the goods under, for 31-27 Machine.....
28366	2645	Binder Folder for 28794, obsolete, use 120493, 120494 or 120495.....
28549	1395	Edge Folder (double) with Separating Blade on Shank, lower folder to turn the edge of the goods up, for 31-27 Machine.....
		Nos. 28590 TO 28594 FOR 28816
28590	1371	Ruffler Driving Lever.....
28591	1371	“ “ “ Spring.....
28592	1371	“ “ “ “ Collar.....
28593	1371	“ Frame.....
28594	1371	Presser Foot (left).....
28596	1371	“ “ (right) Shank for 28814....
28597	1371	“ “ “ “ Cap for 28816
28600	1371	Ruffler Ruffling Blade Lever for 28816...
28601	1371	“ Starting Lever with 190D, for 28816
28603	1370	Feed Dog, 10 teeth (16 teeth to the inch) for 28816.....
28605	1372	Edge Folder (upper, right hand) with left hand lower guide and separating blade on shank, to fold top band only, for making yokes, for 28816.....
28607	1371	Ruffler Ruffling Blade Holder Stop for 28816.....
28611	1396	Binder on Shank, for suspender webs....
28612	1396	Presser Foot for 28611.....
28613	1396	Strip Folder on Shank, for overall shoulder straps.....
28614	1396	Presser Foot for 28613 and 35166.....
28615	1397	Edge Folder with Cord Guide on Shank, to insert and sew on insertion in one operation.....

## NUMERICAL LIST OF PARTS

NO.	PLATE	NAME
28616	1397	Presser Foot (grooved) for 28615.....
28617	1398	Strip Folder on Shank, for inserting folded strip, for trimming mantles.....
28618	1398	Presser Foot (grooved) for strip, for 28617
28619	1399	Binder (horn) on Shank.....
28620	1399	Presser Foot for 28619.....
28621	1397	Piping Attachment and Strip Folder on Shank, for car-seat cushions.....
28622	1397	Presser Foot (grooved) for 28621.....
28623	2602	Hemmer and Corder on Shank, to take goods from above to cord bottom.....
28624	2602	Presser Foot with groove on bottom to the right of needle hole, for 28623.....
28625	2627	Edge Folder (double) with Strip Folder and Cord Tube on Shank, for inserting cord, folding strip and stitching between the two folded edges of goods.....
28626	1391	Presser Foot with groove on bottom to the right of needle hole, for 28625.....
28627	2600	Hemmer on Shank, for $\frac{3}{8}$ in. hem, for Marseilles quilts.....
28628	2600	Presser Foot for 28627.....
28629	1384	Feed Dog, 13 teeth (14 teeth to the inch) for 28788.....
28630	1384	Throat Plate for 28629 for 28788.....
28631	2602	Binder on Shank.....
28632	2602	" " " " to turn edges under....
28633	1399	" " " " " top edge only, for binding coats.....
28634	2602	Binder on Shank, to turn top edge only, for raw edge binding.....
28635	1398	Binder on Shank, for $\frac{1}{8}$ in. binding.....
28636	2601	" " " " to turn top edge only, for men's trouser bottoms.....
28637	2626	Binder on Shank, for bias binding, to turn top edge only, with guide for inserting canvas strip.....
28638	2600	Binder on Shank, for dress shields.....
28639	2603	" " " " to turn top edge only, for suspenders.....
28640	2627	Binder on Shank, for $1\frac{1}{4}$ in. binding, for soft blankets.....
28641	2603	Binder on Shank, for $\frac{1}{8}$ in. binding....
28642	2603	" (horn) on Shank.....
28643	2603	" on Shank with Guide (wire) for mattress work.....

## NUMERICAL LIST OF PARTS

NO.	PLATE	NAME
28646	2604	Edge Folder (double) on Shank, for men's skeleton coat seams, to turn to outside
28647	2626	Strip Folder on Shank.....
28648	2626	" " " " for making straps
28649	2604	Edge Folder on Shank.....
28650	2604	Hemmer on Shank, for hemming heavy Canton flannel.....
28651	2605	Hemmer on Shank, for turning tops and bottoms of canvas leggings.....
28652	2605	Hemmer on Shank, for $1\frac{1}{8}$ in. to 2 in. hem
28653	—	" " " " $2\frac{3}{8}$ in. to 3 in. hem
28654	1383	Throat Plate, for under braiding, for 12369 and 12457.....
28655	1382	Throat Plate, small needle hole, for 12369 and 12457, for 28657.....
28656	—	Throat Plate, large needle hole, for 12369 and 12457, for 28657.....
28657	—	Binder (English) complete, Nos. 190D, 207F, 12369 or 12457, 25721, 25722, 25983, 28655 or 28656 and two 7071...
28658	1377	Guide (roller) with 1852.....
28659	1392	Quilter Guide for 28660.....
28660	1392	Quilter complete, Nos. 25992 and 28659..
28661	2028	Hemmer (foot) $\frac{1}{8}$ in. hem, for gusset work
28662	2028	" " " $\frac{1}{8}$ in. hem, slotted for lace
28663	2028	" " " $\frac{1}{8}$ in. hem, for 12372, 12455, 20002, 20117 and 20151.....
28664	—	Hemmer (foot) $\frac{3}{8}$ in. hem, slotted for lace
28665	2606	Binder (foot).....
28666	2606	" " right hand.....
28667	2606	" " left hand.....
28668	2606	Presser Foot (strip folding).....
28669	2606	Hemmer Spring for 28670.....
28670	2606	" (foot) $\frac{1}{4}$ in. hem, with 28669 and two 26459.....
28671	1392	Hemstitcher.....
28672	1391	Presser Foot, two grooves to the right of needle hole, for cording.....
28673	2607	Lap Seam Feller (right hand) on Shank, to fold top only.....
28674	2607	Lap Seam Guide on Shank.....
28675	1391	Presser Foot (pointed toe) for stitching box plaiting on body of material.....
28676	1381	Presser Foot for 28678 and 28776.....
28677	1381	Throat Plate for 26603 for 28678.....

NO.	PLATE	NAME
28678	—	Binder (English) complete, Nos. 193F, 7071, 26603 or 120001, 28334, 28337, 28676, 28677 and two 233D.....
28679	1376	Hemmer Bed with 28681, for 28688.....
*28680	1376	“ Folder (left) for 28688.....
28681	1376	“ “ (right) for 28679.....
Nos. 28682 to 28686 FOR 28688		
28682	1376	Hemmer Slide with 28687 and two each 2362 and 12152.....
28683	1376	Hemmer Slide Cap (left).....
28684	1376	“ “ “ (right).....
28685	1376	“ Folder Disengaging Lever.....
28686	1376	“ Slide Spring.....
28687	1376	“ “ “ Cover for 28682... ..
28688	1376	Hemmer complete, with lever for opening the folder and releasing the hem so that it can be finished without removing the hemmer from machine, for skirts, overalls or similar closed articles, Nos. 94D, 28679, 28680, 28682 to 28686, two 207F and three 233D.....
28689	—	Presser Foot Plate for 28691.....
28690	—	“ “ Shank for 28691.....
28691	1391	Presser Foot (spring hinged) complete for 28688, Nos. 18055, 26231, 28689 and 28690.....
28692	2607	Presser Foot for 28693.....
28693	2607	Binder on Shank, for binding the arm holes in cotton garments.....
28698	2608	Strip Folder on Shank with cord tube....
28699	2608	Presser Foot, grooved to the right of needle hole, for 28698.....
28700	2609	Hemmer (short head) on Shank, for hemming stable blankets.....
28779	2623	Ruffling Blade for 28777.....
28783	1382	Throat Plate for 20106 for 28784.....
28784	—	Binder (English) complete for 31-19 Machine, Nos. 190D, 207F, 20106, 25721, 25722, 26702, 26703, 28783 and two 7071.....
28788	—	Corder complete, for top and bottom cording, Nos. 25792, 26167, 28629, 28630 and two 135D.....
28790	2645	Feed Dog, 11 teeth (24 teeth to the inch) for 28794 and 28861.....
28791	2645	Lifting Presser Foot for 28794.....

NO.	PLATE	NAME
19416	—	Throat Plate, small needle hole, for 20151 and 44144.....
19418	1262	Throat Plate, large needle hole, for 20158 and 44156.....
19419	—	Throat Plate, small needle hole, for 20158 and 44156.....
19447	2011	Oscillating Shaft Crank complete, Nos. 457c, 1518i, 19449 and 19496.....
19448	2011	Oscillating Shaft Crank Slide Block for 19449.....
19449	2011	Oscillating Shaft Crank Slide Block complete for 19447 and 44135, Nos. 226D, 988c, 12424 and 19448.....
19474	1258	Feed Dog, 14 teeth (16 teeth to the inch) for corset work, for 31-15 Machine, 26402, 35208, 35209, 35236, 35241, 35324, 35325, 35345, 35351 and 36906.....
19475	1258	Throat Plate, large needle hole, for 19474.....
19496	—	Oscillating Shaft Crank for 12390 and 19447.....
19497	1261	Throat Plate, large needle hole, for 20117.....
20002	778	Feed Dog, 18 teeth (16 teeth to the inch) beveled for hemmer, for 31-15 Machine.....
20003	—	Shuttle Race Body for 20005.....
20004	2005	“ “ Cap for 20005.....
20005	2005	Shuttle Race (sectional) complete for 31-16 Machine, Nos. 648D, 2531, 2533, 12492 to 12494, 20003, 20004 and two each 85D, 662D, 2532 and 21202.....
20008	—	Foot Lifter complete for 31-15, 31-16, 31-20, 31-22, 31-27, 31-32 and 31-34 Machines, Nos. 76D, 766D, 802D, 1521E, 4880, 4885, 5598, 5670, 12237, 12240, 12241, 12415, 12416 and two 178E.....
20009	1258	Feed Dog, for tailor work, for 31-15, 31-20 and 31-22 Machines, obsolete.....
20010	1258	Throat Plate, large needle hole, for 20009, obsolete, use 44137.....
20018	1258	Feed Dog, 17 teeth (15 teeth to the inch) for finishing knit underwear, for 31-15 Machine.....
20019	1258	Throat Plate, large needle hole, for 20018.....
20020	1308	Presser Foot for 20018.....
20021	5761	Drip Pan with four 1 in. wire nails, for power table, for Drop Feed Machines, obsolete, use 44212.....



NO.	PLATE	NAME
20022	5742	Machine Rest (felt) for machine on stand (Trimnings for End and Back Leaf Table).....
20023	2004	Lifting Presser Bar Spring (heavy) .063 wire, for 31-19 Machine.....
20023	2004	Presser Bar Spring (heavy) .063 wire, for 31-15, 31-16, 31-20, 31-22, 31-24, 31-27, 31-32, 31-34, 31-35 and 31-37 Machines.....
20024	—	Throat Plate, small needle hole, for 20009, obsolete, use 44138.....
20037	2009	Tension Releaser for 44147, obsolete.....
20038	780	Presser Foot for 20303.....
20039	5760	Starting Treadle Centre Bracket with 28054 and two wood screws 1 in. No. 10, for 31-42 Machine.....
20040	5760	Starting Treadle Screw Centre Bracket with 46661 and two wood screws 1 in. No. 10, for 31-42 Machine.....
20057	—	Face Plate for 20058.....
20058	5735	Face Plate complete for 31-15, 31-16, 31-20, 31-22, 31-24, 31-27, 31-32, 31-34 and 31-37 Machines, Nos. 2827, 12150 and 20057.....
20059	5736	Presser Bar Guide Bracket with 453c, for 31-15, 31-16, 31-20, 31-24, 31-27, 31-32, 31-34 and 31-37 Machines.....
20060	5736	Slack Thread Regulator for 31-15, 31-16, 31-20, 31-22, 31-24, 31-32, 31-34 and 31-37 Machines.....
Nos. 20061 to 20063 for 31-15, 31-16, 31-20, 31-22, 31-24, 31-27, 31-32, 31-34 and 31-37 MACHINES, OBSOLETE		
20061	1353	Tension Screw Stud Bushing.....
20062	1353	“ “ “ Flange.....
20063	1353	“ “ “ Collar.....
20064	2014	“ Thread Guard, obsolete.....
20067	819	Bed Frame with two each 16555, 19398, four each 19219, 19220, six each 14010, wood screws 1¼ in. No. 12 and eight 158c, for all machines and also for 31-42 Machine when operated head on.....
20091	5735	Rock Shaft for 20465.....
20106	1259	Feed Dog, for cloth, 13 teeth (16 teeth to the inch) for 31-19 and 31-20 Machines and 28784.....
20107	1259	Throat Plate, small needle hole, for 20106.....

NO.	PLATE	NAME
20117	1261	Feed Dog, 16 teeth (16 teeth to the inch) for shirt work, beveled for hemmer, for 31-20 Machine.....
20119	1259	Feed Dog, 18 teeth (16 teeth to the inch) for heavy work on duck, overalls, etc., for 31-15 and 31-20 Machines.....
20120	1259	Throat Plate, large oblong needle hole, for 20119.....
20138	1263	Feed Dog, 13 teeth (12 teeth to the inch) for shirt work, beveled for hemmer, for 31-20 and 31-24 Machines.....
20141	—	Driving Attachment with Bobbin Winder and Treadle complete for 31-20, 31-22 and 31-24 Machines, Nos. 210D, 692D, 12475, 16592, 16594, 19260, 20372, 24355, 27072, 27308, 44176, 126213 and two 65D.....
20147	1260	Feed Dog, for shirt work, 12 teeth (14 teeth to the inch) for 31-20 Machine...
20151	1262	Feed Dog, 13 teeth (14 teeth to the inch) for shirt work, beveled for hemmer, for 31-20 Machine.....
20155	—	Presser Foot Plate for 20157.....
20156	—	“ “ Shank for 20157.....
20157	780	Presser Foot (hinged) complete for 25967 and 26279 to 26283, Nos. 228D, 20155, 20156 and 62527.....
20158	1262	Feed Dog, 17 teeth (16 teeth to the inch) for shirt work, for 31-20 Machine.....
20162	1263	Feed Dog, 17 teeth (16 teeth to the inch) for shirt work, beveled for hemmer, for 31-20 and 31-24 Machines.....
20185	2011	Tension Releaser for 20370 for 31-22 Machine, obsolete.....
20186	2011	Tension Releasing Lever for 31-22 Machine, obsolete.....
20187	—	Throat Plate, small oblong needle hole, for 20119.....
20188	767	Needle Bar Crank with 858c and 1065c, for 44122, 44124, 44130, 44169, 44172 and 44217.....
20192	—	Throat Plate, small oblong needle hole, for 20329, obsolete.....
20197	2001	Crank Connecting Rod with 20198 and two 896E, for 44189, 44192, 44195 to 44197, 44199, 44200, 44207 and 44217...
*20198	—	Crank Connecting Rod Cap for 20197...

## NUMERICAL LIST OF PARTS

NO.	PLATE	NAME
*20236	—	Arm with 11104, for 31-24 Machine.....
*20237	—	Bed for 31-24 Machine.....
20238	2000	Feed Rock Shaft for 20239 and 20334....
20239	—	Feed Rock Shaft complete for 31-24 Machine, Nos. 3043, 20238 and 20247, obsolete, use 20334.....
20240	2019	Presser Bar Lifter for 31-24 Machine....
20241	—	“ Foot Body for 20243.....
20242	2019	“ “ Roller for 20243.....
20243	2019	Presser Foot (roller) complete for 31-24 Machine, Nos. 131D, 1550J, 20241 and 20242.....
Nos. 20244 to 20246 FOR 20253		
20244	2019	Reciprocating Spring Presser Blade.....
20245	2019	“ “ “ “ Holder
20246	2019	“ “ “ “ Spring Bracket.....
20247	2020	Reciprocating Spring Presser Regulator Crank with 1518J, 1942 and two 190D, for 20239 and 20334.....
Nos. 20248 to 20251 FOR 31-24 MACHINE		
20248	2000	Reciprocating Spring Presser Shaft.....
20249	2020	“ “ “ “ Bracket (back).....
20250	2020	Reciprocating Spring Presser Shaft Bracket (front).....
20251	2019	Reciprocating Spring Presser Shaft Collar with 456c.....
20252	2019	Reciprocating Spring Presser Shaft Crank (front) with 7483 and two 453c, for 20253.....
20253	—	Reciprocating Spring Presser Shaft Crank (front) complete for 31-24 Machine, Nos. 1099F, 9804, 20244 to 20246, 20252 and two 233D.....
20254	2020	Reciprocating Spring Presser Shaft Crank (back) with 191F, for 31-24 Machine....
20255	2020	Lifting Lever Connecting Rod for 20256, 20290 and 43933.....
20256	—	Knee Lifter complete (power table or stand 25265) for 31-24 Machine, Nos. 76D, 766D, 802D, 1521E, 5598, 12237, 12240, 12241, 12250, 12416, 20255 and two 178E.....
20268	—	Presser Foot Plate for 20270.....

## NUMERICAL LIST OF PARTS

NO.	PLATE	NAME
20269	—	Presser Foot Shank for 20270.....
20270	1308	Presser Foot (hinged) complete for 12369, 12457, 20106 and 20349, Nos. 7298, 20268 and 20269.....
20275	1259	Feed Dog, 13 teeth (18 teeth to the inch) for umbrella work, for 31-15 Machine..
20276	1259	Presser Foot for 20275.....
20277	1259	Throat Plate, large needle hole, for 20275
20283	2020	Feed and Feed Lifting Eccentric with 446c for 44121 to 44123, 44130, 44169 and 31-37 Machine.....
20284	2020	Feed Forked Connection for 43993.....
20290	—	Foot Lifter complete for 31-24 Machine, Nos. 76D, 766D, 802D, 1521E, 4880, 4885, 5598, 5670, 12237, 12240, 12241, 12416, 20255 and two 178E.....
20291	2049	Drip Pan with four 1 in. wire nails, for power table, for Wheel Feed Machines
20303	776	Feed Dog, 12 teeth (12 teeth to the inch) for 31-32 Machine, obsolete.....
20304	778	Feed Dog, 13 teeth (12 teeth to the inch) for 31-32 Machine.....
20307	2020	Bobbin Winder Frame for 20308.....
20308	—	Bobbin Winder Frame complete for 20309, Nos. 333D, 5960, 5961, 5963, 15077 and 20307.....
20309	—	Bobbin Winder complete for 12358, Nos. 32D, 180F, 12168, 12170 and 20308....
20310	—	Presser Foot Plate for 20311.....
20311	781	Presser Foot (hinged) complete for 12372, 12437, 12455, 12468, 12481, 20002, 20117, 20138, 20147, 20151, 20158, 20162, 20336 and 20471, Nos. 2532, 19223 and 20310.....
*20312	—	Arm with 11104, for 31-27 Machine.....
*20313	—	“ “ 11104, for 31-32 Machine.....
20314	1353	Tension Releaser for 29549, obsolete....
20315	—	Throat Plate, large needle hole, for 20106
20321	2048	Arm Shaft Bushing (back) for 31-42 Machine.....
20328	781	Presser Foot for 20303.....
20329	776	Feed Dog for 31-32 Machine, obsolete....
20332	2049	Arm Shaft for 44130.....
20333	—	Feed Rock Shaft complete for 31-15, 31-16, 31-19, 31-20, 31-22, 31-27, 31-32, 31-34, 31-35 and 31-37 Machines, Nos. 12379 and 29633.....

NO.	PLATE	NAME
20334	—	Feed Rock Shaft complete for 31-24 Machine, Nos. 20238, 20247 and 29633
20336	1274	Feed Dog, 16 teeth (16 teeth to the inch) beveled for hemmer, for shirt work, for 31-15 Machine.....
20337	—	Throat Plate, large needle hole, for 20336
20338	1274	" " small needle hole, for 20336
*20339	—	Arm with 11104, for 31-19 Machine.....
20340	2049	Lifting Lever with 448c, for 20341, 43928 to 43931 and 43934.....
20341	—	Knee Lifter complete (power table or stand 25265) for 31-19 Machine, Nos. 76d, 766d, 802d, 1521e, 5598, 12250, 12415, 12416, 19372, 20340, 21301 and two 178e.....
20342	781	Presser Foot for 12450 and 20348.....
20343	781	" " with guide on bottom to the right of needle hole, for 12369, 12450, 12457 and 20348.....
20344	—	Presser Foot Plate for 20346.....
20345	—	" " Shank for 20346.....
20346	781	Presser Foot (spring hinged) complete for 12372, 12437, 12455, 12468, 12481, 20002, 20117, 20138, 20147, 20151, 20158, 20162, 20336, and 20471, Nos. 20344, 20345, 26231 and 62527.....
20347	2048	Reciprocating Spring Presser Blade (slotted) for 31-24 Machine.....
20348	777	Feed Dog, 22 teeth (36 teeth to the inch) for chiffon, for 31-15 and 31-20 Machines
20349	1267	Feed Dog, 13 teeth (16 teeth to the inch) for 31-15 Machine.....
20350	1267	Throat Plate, large needle hole, for 20349
20351	—	" " small needle hole, for 20349
20352	1267	Feed Dog, 15 teeth (16 teeth to the inch) for general muslin work, for 31-15 Machine.....
20353	1267	Throat Plate, large needle hole, for 20352
20354	—	" " small needle hole, for 20352
20355	1274	Feed Dog, 14 teeth (12 teeth to the inch) for 31-34 Machine.....
20356	1274	Throat Plate, large needle hole, for 20355
20357	—	" " small needle hole, for 20355
20358	—	Presser Foot Plate for 20359.....
20359	781	Presser Foot (hinged) complete, for $\frac{3}{16}$ in. gauge and above, for 20355, Nos. 19335, 20358 and 26276.....

NO.	PLATE	NAME
20362	—	Throat Plate, small needle hole, for 20275
20363	5757	Presser Bar Spring (heavy) .0405 wire, for 31-42 Machine.....
20364	2045	Wrench for 1648 (Attachments and Accessories).....
20367	770	Needle Bar Connecting Stud Slide Block for 20368, obsolete.....
20368	770	Needle Bar Connecting Stud complete, Nos. 453c, 12383 and 20367, obsolete, use 12384.....
20370	2048	Tension Releasing Lever for 20185 for 31-22 Machine, obsolete.....
20371	768	Driving Attachment Driving Arm Pitman Crank for 44176.....
20372	768	Driving Attachment Driving Arm Pitman Crank Spring for 12478 and 20141.....
20398	—	Throat Plate, large needle hole, for 12455 Nos. 20399 to 20455 FOR 31-37 MACHINE
*20399	—	Arm with 11104, obsolete.....
20400	5735	" Shaft, for 44169.....
*20401	—	Bed.....
20402	5756	Edge Guide, for 31-37 Machine, obsolete
20403	5744	Feed Dog, 11 teeth (22 teeth to the inch)
20404	5745	Plaiting Blade (lower).....
20405	5746	" " (upper).....
20406	5745	" " Holder (lower).....
20407	5756	" " " Hinge Stud for 20438, obsolete.....
20408	5745	Plaiting Blade Holder (lower) Spring....
20409	5756	" " " " Stop for 20438, obsolete.....
20410	5746	Plaiting Blade Holder (upper).....
20411	5746	" " " " Spring....
20412	5745	" " Separating Spring.....
20413	5747	" Cam No. 1.....
20414	5747	" " " 2.....
20415	5747	" " " 3.....
20416	5747	" " " 4.....
20417	5748	" " " 5.....
20418	5748	" " " 6.....
20419	5748	" " " 7.....
20420	5748	" " " 8.....
20421	5749	" " " 9.....
20422	5750	" " Shaft with 8386.....
20423	5751	" " " Bracket with 155c and 449c.....
20424	5750	Plaiting Eccentric with two 458c.....

NO.	PLATE	NAME
20425	5750	Plaiting Gear (back) with two 178f.....
20426	5752	“ “ (front) with two 882c, for 44169.....
20427	5746	Plaiting Gear (intermediate) large, for 20428.....
20428	—	Plaiting Gear (intermediate) large, 20427 with 9754 and 20429.....
20429	5746	Plaiting Gear (intermediate) small, for 20428.....
20430	5746	Plaiting Gear (intermediate) Stud.....
20431	5757	“ “ Cover, for 31-37 Machine, obsolete.....
20432	5751	Plaiting Lever.....
20433	5751	“ “ Bracket with two 443c....
20434	5752	“ “ Connecting Rod with two 794E.....
20435	5752	Plaiting Lever Hinge Stud.....
20436	5752	“ Regulating Stud.....
20437	5752	“ “ “ Nut Washer....
20438	5756	“ Rock Shaft for 20409, for 31-37 Machine, obsolete.....
20439	5752	Plaiting Rock Shaft Crank with two 200f
20440	5753	“ “ “ Lever.....
20441	5753	“ “ “ “ Arm.....
20442	5753	“ “ “ “ “ H i n g e Stud.....
20443	5753	Plaiting Rock Shaft Lever Connecting Rod.....
20444	5753	Plaiting Rock Shaft Lever Connecting Rod Crank with 1961.....
20445	5744	Presser Foot.....
20446	5754	Separating Blade.....
20447	5751	“ “ “ Bracket.....
20448	5754	“ “ “ Holder.....
20449	—	Shuttle Race Slide for 20450.....
20450	5754	Shuttle Race Slide complete, Nos. 4307, 20449 and two 50216E.....
20451	5755	Strip Guide (left).....
20452	5755	Strip Guide (right).....
20453	5755	“ “ “ Holder (back).....
20454	5755	“ “ “ “ (front).....
20455	5744	Throat Plate for 20403.....
20458	780	Presser Foot for 44136.....
20461	2045	Wrench for 1582 and 1668 (Attachments and Accessories).....
20462	5735	Rock Shaft Knee Arm Hub with 356c, for 20463.....

NO.	PLATE	NAME
20463	—	Rock Shaft Knee Arm complete for 20465, Nos. 2765, 2767 and 20462.....
20464	5735	Rock Shaft Lifting Arm with 356c, for 20465.....
20465	5735	Rock Shaft complete for 20466, 43931, 43933 and 43934, Nos. 2764, 16128, 20091, 20463, 20464, and two 2770....
20466	—	Knee Lifter complete (Stand 25255) for 31-15, 31-16, 31-20, 31-22, 31-27, 31-32 and 31-34 Machines, Nos. 76d, 766d, 802d, 1521E, 5598, 12237, 12240, 12241, 12415, 12416, 20465 and two 178E....
20467	5762	Drip Pan with eight 1 in. wire nails, for Stand No. 25255.....
20471	777	Feed Dog, 22 teeth (22 teeth to the inch) beveled for hemmer, for shirt work, for 31-15 Machine.....
*20490	—	Arm with 11104, for 31-37 Machine.....
20491	5751	Plaiting Gear Cover with 20492 and two 402d, for 31-37 Machine.....
20492	5751	Plaiting Gear Cover Plate for 20491.....
20498	—	Bobbin Winder (Hamburg) complete for 4370, Nos. 32d, 180f, 12168, 12170 and 43983.....
20590	—	Shuttle, 1 $\frac{1}{4}$ in. diam., Nos. 19131, 20591 and 20596, for 31-20 Machine, obsolete, use 20655.....
20591	2012	Shuttle Bobbin Case complete for 20590, Nos. 591f, 592E, 2521, 2523, 20592, 20595 and 20600, obsolete, use 20653..
20592	—	Shuttle Bobbin Case Hinge, Nos. 2974, 20593 and 20594, for 20591, obsolete, use 20652.....
20593	2012	Shuttle Bobbin Case Latch for 20592 and 20652, obsolete.....
20594	2012	Shuttle Bobbin Case Latch Lever for 20592, obsolete.....
20595	2012	Shuttle Bobbin Case Position Finger for 20591, 20651 and 20653, obsolete.....
20596	2012	Shuttle Body for 20590 and 20655, obso- lete.....
20600	2012	Shuttle Tension Spring for 20591, obsolete
20649	2012	Shuttle Bobbin Case Latch for 20650....
20650	—	Shuttle Bobbin Case Hinge, Nos. 2973, 2974 and 20649, for 20651 and 20756..

NO.	PLATE	NAME
20651	2012	Shuttle Bobbin Case complete for 20655, Nos. 591F, 592E, 2523, 2975, 20595, 20650 and 20654, obsolete.....
20652	—	Shuttle Bobbin Case Hinge, Nos. 2973, 2974 and 20593, for 20653, obsolete....
20653	2012	Shuttle Bobbin Case complete for 20655, Nos. 591F, 592E, 2521, 2523, 20595, 20652 and 20654, obsolete, use 20651..
20654	2012	Shuttle Tension Spring for 20651, 20653 and 20756.....
20655	2012	Shuttle, 1 $\frac{1}{4}$ in. diam., Nos. 19131, 20596 and 20651, for 31-20, 31-22 and 31-24 Machines, obsolete.....
20755	5737	Shuttle Bobbin Case Position Finger for 20756.....
20756	5737	Shuttle Bobbin Case complete for 20758, Nos. 591F, 592E, 2523, 2975, 20650, 20654 and 20755.....
20757	5737	Shuttle Body for 20758.....
20758	5737	Shuttle, 1 $\frac{1}{4}$ in. diam., Nos. 19131, 20756 and 20757, for 31-20, 31-22 and 31-24 Machines.....
21202	5837	Shuttle Race Ring Clamp Friction Spring for 20005.....
21301	1353	Lifting Lever Link for 20341, 43928 and 43931.....
22003	2045	Wrench for 1550 (Attachments and Accessories).....
23219	2645	Presser Foot Edge Guide Position Pin for 28858.....
23258	8628	Driving Attachment Treadle Bracket (left) Hook Friction Washer for 126206.....
24008	—	Shuttle Race Body for 62623, obsolete...
24009	2006	“ “ Cap for 24120, 24998 and 62623.....
24010	1357	Shuttle Race complete for 31-20 Machine, Nos. 648D, 2419, 2533, 62623 and two 2532, obsolete, use 24325.....
24020	2009	Oil Cup for 24024, obsolete.....
24023	2009	“ “ Extension with 24075 for 24024, obsolete.....
24024	2009	Oil Cup complete for 31-16 Machine, Nos. 12486, 24020, 24023, obsolete, use 44007
24036	2020	Feed and Feed Lifting Eccentric Sleeve for 44121 to 44123 and 44130.....

NO.	PLATE	NAME
24074	2013	Shuttle Bobbin Case complete for 12487 and 19292, Nos. 591F, 592E, 2523, 2975, 7553, 15098 and 15141, obsolete, use 62740.....
24075	2565	Oil Cup Extension Post for 24023 and 44005
24101	—	Needle Clamp Body for 24103.....
24102	2011	“ “ Thread Guard for 24103..
24103	2011	Needle Clamp (high lift) complete for 31-22 and 31-24 Machines, Nos. 651D, 808F, 24101 and 24102.....
*24104	2001	Oscillating Rock Shaft for 24105.....
24105	—	Oscillating Rock Shaft complete, Nos. 4784, 12388 and 24104.....
24109	1321	Knife Holder Handle for 24128.....
24117	2006	Shuttle Bobbin Case Guide Plate for 24120, obsolete.....
24118	—	Shuttle Race Body for 24120, obsolete...
24120	2006	Shuttle Race complete for 31-20, 31-22 and 31-24 Machines, Nos. 907D, 2419, 2533, 24009, 24117, 24118, two 2532 and four 1053D, obsolete, use 24325.....
24122	1317	Knife Bar Lifting Spring for 31-35 Machine.....
24123	1317	Knife Bar Lifting Spring Case for 31-35 Machine.....
24124	1317	Knife Bar Lifting Spring Guide for 24906
24125	1317	“ “ “ “ Bracket for 24906.....
24128	—	Knife Bar complete for 31-35 Machine, Nos. 621D, 19297, 19391, 24109, 24906 and three 335H.....
24131	2014	Arm Oil Tube with 52045, for oiling 12197, 12428 and 20283.....
Nos. 24199 to 24201 for 31-27 MACHINE		
24199	1323	Ruffling Arm Shaft.....
24200	1324	“ “ “ Bracket (right).....
24201	1324	“ “ “ “ (left).....
24203	1371	Ruffler Ruffling Blade Holder for 28816..
24203	1344	Ruffling Blade Holder for 28845.....
24204	1371	Ruffler Ruffling Blade Holder Spring for 28816.....
24204	1344	Ruffling Blade Holder Spring (light, right) for 28845.....
24205	1371	Ruffler Ruffling Blade Holder Spring Stop for 28816.....

NO.	PLATE	NAME
24205	1344	Ruffling Blade Holder Spring (right) Stop for 28845.....
24206	1371	Ruffler Ruffling Blade Holder Stud for 28816.....
24206	1344	Ruffling Blade Holder Stud for 28845....
24207	1323	" " Eccentric with two 453c, for 44130.
24208	1323	" " Collar with 453c, for 44130.....
24210	1324	Ruffling Eccentric Connection Washer for 31-27 Machine.....
24211	1323	Ruffling Regulator with 225e, for 31-27 Machine.....
24219	1323	Ruffling Eccentric Connection with 24220 and two 742e, for 31-27 Machine.....
*24220	—	Ruffling Eccentric Connection Cap for 24219.....
24303	1344	Feed Dog, 6 teeth (14 teeth to the inch) for 31-27 Machine and 26018.....
24304	1344	Presser Foot for 31-27 Machine.....
24305	1344	Ruffling Blade for 31-27 Machine.....
24306	1344	Throat Plate for 24303.....
24323	2046	Shuttle Bobbin Case Position Plate for 24325.....
24324	—	Shuttle Race Body for 24998.....
24325	2046	Shuttle Race complete for 31-20, 31-22 and 31-24 Machines, Nos. 907d, 2419, 2533, 24323, 24998 and two each 391d and 2532.....
24344	1267	Feed Dog, 17 teeth (14 teeth to the inch) for 26956.....
24355	5757	Driving Attachment Balance Wheel Oil Cover for 12478 and 20141.....
24391	1321	Needle Bar Thread Guide for 16568.....
24412	1361	Shuttle Bobbin Case Position Plate for 24415 and 24419.....
24413	—	Shuttle Race Body for 25000 and 62502..
24414	5837	" " Cap for 25000.....
24415	1361	Shuttle Race complete for 31-15, 31-27, 31-32, 31-34, 31-37, 31-39 and 31-42 Machines, Nos. 907d, 2531, 2533, 24412, 25000 and two each 391d and 2532....
24418	8628	Shuttle Race Cap for 62502.....
24419	—	Shuttle Race complete for 31-19 and 31-35 Machines, Nos. 907d, 2531, 2533, 24412, 62502 and two each 391d and 2532....
24431	5841	Knife Bar Crank with 191c, for 24432...

NO.	PLATE	NAME
24432	—	Knife Bar Crank complete for 24433, Nos. 1162c, 1564d, 2297 and 24431.....
24433	—	Knife Bar Driving Crank Bracket complete for 31-35 Machine, Nos. 2022, 16563, 16564 and 24432.....
24488	—	Presser Foot Plate for 24489.....
24489	5837	Presser Foot (hinged) complete, for heavy work, Nos. 19223, 24488 and 62527....
24544	—	Presser Foot Plate for 24546 and 24983..
24545	—	" " Shank for 24546, obsolete..
24546	780	Presser Foot (spring hinged) complete for 12425, 12481, 19474 and 20119, Nos. 24544, 24545, 26231 and 62527, obsolete
24572	2067	Throat Plate, small needle hole, for 19474 and 35351.....
24573	1271	Feed Dog, 24 teeth (32 teeth to the inch) for 31-35 Machine.....
Nos. 24579 TO 24582 FOR 31-27 MACHINE		
24579	2014	Ruffling Blade Holder Spring (heavy, left)
24580	2014	" " " " (heavy, right)
24581	2014	" " " " (light, left)..
24582	1344	" " " " (left) Stop..
24589	5736	Lifting Presser Bar Guide Bracket with 453c, for 24716.....
24590	5736	Lifting Presser Bar Guide Bracket Support for 31-19 Machine.....
24716	—	Lifting Presser Bar Guide Bracket complete for 31-19 Machine, Nos. 19356, 19357, 19366, 24589 and three 199d.....
24722	1271	Presser Foot, for $\frac{1}{8}$ in. to $\frac{1}{4}$ in. gauge, for 31-35 Machine.....
*24906	—	Knife Bar Lifting Spring Guide 24124 with 2523 and 24125, for 24128.....
24982	—	Presser Foot Shank for 24983.....
24983	781	Presser Foot (spring hinged) complete for 12425, 12481, 19474 and 20119, Nos. 24544, 24982, 26231 and 62527.....
24998	—	Shuttle Race Body 24324 with 24009 and two 1053d, for 24325.....
25000	—	Shuttle Race Body 24413 with 24414 and two 1053d, for 24415.....
Nos. 25001 TO 25003 (TRIMMINGS FOR END AND BACK LEAF TABLE)		
25001	3825	Back Leaf Bracket with two wood screws 1 in. No. 10.....

NO.	PLATE	NAME
25002	3825	Back Leaf Scroll Bracket with $\frac{3}{4}$ in. No. 9 and two 1 in. No. 12 wood screws.....
25003	3825	Back Leaf Sliding Hinge, Nos. 25149, three 25151 and six wood screws $\frac{3}{4}$ in. No. 7
25016	—	Belt, size $\frac{1}{4}$ in., length 69 $\frac{1}{2}$ in., with 25127, from band wheel to machine, for 25265 and 25284.....
25057	3825	End Leaf Support complete, Nos. 25143, 25168, 25169 and two wood screws $\frac{5}{8}$ in. No. 7 (Trimnings for End and Back Leaf Table).....
25060	3825	End Leaf Support Button with wood screw 1 $\frac{1}{2}$ in. No. 12 R. H. B. (Trimnings for End and Back Leaf Table).....
25082	5760	Treadle for 25279.....
25082	5760	Starting Treadle for 31-42 Machine.....
25086	3813	Wrench for 1507, 1510 and 1670, for 25255 25265, 25279 and 25284.....
25089	5741	Starting Treadle Pitman Cotter Pin for 43816.....
25104	5741	Stop Wheel Pin for 31-42 Machine.....
25127	3817	Belt Hook for 25016, 25370, 25490 and 46657.....
25143	5742	End Leaf Support Lever Hinge Pin for 25057.....
25149	3825	Back Leaf Sliding Hinge Rod for 25003..
25151	3825	" " " " Plate for 25003
25168	3825	End Leaf Support Bracket for 25057.....
25169	3825	" " " Lever for 25057.....
25200	3825	Wrench for 972 for 25265 and 25284.....
25255	—	Stand (iron work) high speed, complete, Nos. 25086, 25329, 25421, 25430 to 25432, 25436 to 25438, 46604, 46605, two each 25345, 25349, 25350, 25433 and four each 534R, 748R, 1508R and 25446.....
25265	—	Stand (iron work) rocking treadle, ball bearing pitman, complete, Nos. 25086, 25200, 25301, 46520, 46524, 82985, two 82973 and four 748R.....
25279	—	Stand (iron work) complete, for Electric Motor, Nos. 7958, 25082, 25086, 82985, two 82973 and four 748R.....

NO.	PLATE	NAME
25284	—	Stand (iron work) rocking treadle, ball bearing pitman, complete, for foot power and S. D. 11 or S. D. 12 Electric Motors, Nos. 10875, 25086, 25200, 25301, 46524, 46656, 82985 two 82973 and four 748R..
25301	3825	Band Wheel, 16 in. diam., with 972c, for 25265 and 25284.....
25329	3813	Band Wheel, 16 in. diam., with 1312c, for 25255.....
25330	3816	Band Wheel, Brake (rubber) for 25418, obsolete.....
25345	3813	Driving Segment (rack) for 25255.....
25349	3813	Foot Rest for 25255.....
25350	3817	" " Cotter Pin for 25255.....
25350	5740	Starting Bell Crank Pitman Stud Cotter Pin for 12344.....
*25360	—	Pitman Rod Ball for 46523.....
*25360	—	" " (lower) Ball for 46658.....
25361	3826	" " Ball Screw Bearing for 46630
25361	3826	" " (lower) Ball Screw Bearing for 46630.....
25362	3826	Pitman Ball, size $\frac{1}{8}$ in., for 46520 and 46656.....
25370	—	Belt, size $\frac{1}{4}$ in., length 67 $\frac{1}{2}$ in., with 25127, for 25255.....
25371	3826	Pitman Rod Ball Bushing for 46520.....
25371	3826	" " (lower) Ball Bushing for 46656.....
25418	3814	Band Wheel Brake Lever with 443c and 25330, for 25255, obsolete.....
25419	3816	Band Wheel Brake Lever Hinge Pin for 25418, obsolete.....
25420	3816	Band Wheel Brake Lever Spring for 25418 obsolete.....
25421	3814	Band Wheel Shaft for 25255.....
		Nos. 25422 to 25424 for 46604
25422	3815	Band Wheel Shaft Driver (left).....
25423	3815	" " " " " Clutch (left).....
25424	3815	Band Wheel Shaft Driver (left) Clutch (right) with 5564.....
25425	3817	Band Wheel Shaft Driver (left) Clutch Spring.....
25425	3817	Band Wheel Shaft Driver (right) Clutch Spring for 46605.....

## NUMERICAL LIST OF PARTS

NO.	PLATE	NAME
Nos. 25426 TO 25428 FOR 46605		
25426	3815	Band Wheel Shaft Driver (right).....
25427	3815	“ “ “ “ Clutch (left).....
25428	3815	Band Wheel Shaft Driver (right) Clutch (right) with 5564.....
25429	3815	Band Wheel Shaft Driving Flange with 356c, for 46604 and 46605.....
Nos. 25430 TO 25433 FOR 25255		
25430	3814	Brace .....
25431	3813	Driving Arm (left) with 435c and 25435
25432	3813	“ “ (right) with 435c and 25435
25433	3816	“ “ Hinge Pin.....
25434	3815	“ Pinion for 46604 and 46605.....
25435	3816	Foot Rest Hinge Pin for 25431 and 25432
Nos. 25436 TO 25438 FOR 25255		
25436	3813	Leg (left).....
25437	3813	“ (right).....
25438	3814	“ Stay Rod.....
25446	3817	Driving Segment Bolt Nut Washer for 25255
25490	—	Belt, size ¼ in., length 36 in., with 25127, for 25279.....
25644	2024	Binder Bed with 25645, for 25650.....
25645	2024	“ Folder for 25644.....
Nos. 25646 TO 25648 FOR 25650, 25653 AND 25656		
25646	—	Binder Folder Guide (lower) with 25855
25647	2024	“ “ “ (upper).....
25648	2024	“ Pressure Spring.....
25650	2024	Binder (adjustable, size 1) complete, Nos. 334d, 1577d, 7071, 25644 and 25646 to 25648.....
25651	—	Binder Bed with 25652, for 25653.....
25652	—	“ Folder for 25651.....
25653	—	Binder (adjustable, size 2) complete, Nos. 334d, 1577d, 7071, 25646 to 25648 and 25651.....
25654	—	Binder Bed with 25655, for 25656.....
25655	—	“ Folder for 25654.....
25656	—	Binder (adjustable, size 3) complete, Nos. 334d, 1577d, 7071, 25646 to 25648 and 25654.....

## NUMERICAL LIST OF PARTS

NO.	PLATE	NAME
28792	2645	Throat Plate for 28790, for 28794 and 28861.....
28793	2645	Vibrating Presser Foot for 28794.....
28794	—	Binder complete, for circular binding, for sandals, slippers, shoe tongues, etc., for 31-19 Machine, Nos. 207f, 337d, 7071, 7806, 28790 to 28793, 36620 and 120493, 120494 or 120495.....
28795	—	Hemmer (foot) plain bottom, ⅜ in. hem
28803	2619	Piping Attachment on Shank, for flannel without cord.....
28804	2619	Binder on Shank, for binding dress shields
28811	2625	Edge Folder (suspended) right hand, com- plete, for turning edge and ruffling folded edge on skirts, for 31-27 Machine.....
28813	1371	Presser Foot (right) Plate for 28814.....
28814	—	Presser Foot (right) complete for 28816, Nos. 2521, 28596, 28813 and 62527....
28815	1371	Ruffler Ruffling Blade for 28816.....
28816	1370	Ruffler (power) complete, with lever for throwing ruffling blade into action, for intermittent ruffling, such as yoking shirts, etc., Nos. 185h, 226d, 560b, 706d 1049d, 1101c, 1550h, 1603e, 1647c, 2656 24203 to 24206, 26719, 28590 to 28594, 28597, 28600, 28601, 28607, 28814, 28815, two 665d and three 198d.....
28817	1370	Throat Plate for 28603.....
28818	1372	Double Edge Folder (right hand) with separating blade, for ruffling shirt body and putting in yoke for 28816.....
Nos. 28823 TO 28827 FOR 28828		
28823	2646	Binder on Shank.....
28824	2646	Feed Dog, 6 teeth (24 teeth to the inch)..
28825	2646	Lifting Presser Foot.....
28826	2646	Throat Plate for 28824.....
28827	2646	Vibrating Presser Foot.....
28828	—	Binder complete, for circular binding (bias binding) for suspender ends and tabs with movable folder for finishing off, for 31-19 Machine, Nos. 207f, 7071 and 28823 to 28827.....
28830	1387	Presser Foot (grooved) for cording, for carriage work.....



## NUMERICAL LIST OF PARTS

NO.	PLATE	NAME
28833	2649	Edge Folder (left hand) on Shank, with right hand upper folder and separating blade for 31-27 Machine.....
28838	2650	Edge Guide (suspended) left hand, for 31-27 Machine.....
28845	—	Ruffling Arm (adjustable) complete for 31-27 Machine, Nos. 226D, 1550H, 24203 to 24206, 26890 and two 665D.....
28848	2648	Strip Folder on Shank, for folding overall straps.....
28849	1387	Presser Foot with guide on bottom to the left of needle hole, for 28848.....
28851	2648	Binder on Shank, for 3 in. strip of bobbinette material, to bind ¼ in. wide.....
28857	2645	Binder Folder for 28861.....
28858	2645	Presser Foot with 242D, 23219 and 28859, for 28861.....
28859	2645	Presser Foot Edge Guide for 28858.....
28860	2645	Binder Strip Guide for 28861.....
28861	—	Binder complete, for circular binding (bias folded strips) for ladies' lawn ties, etc., Nos. 28790, 28792, 28857, 28858, 28860 and two each 207F and 7071.....
28862	2649	Edge Folder (double) on Shank, right hand upper, left hand lower, with separating blade, for wrappers, for 31-27 Machine.....
28903	2782	Edge Folder (left hand) with right hand upper guide on Shank, to turn up the body of bobbinette curtains and sew on insertion in one operation.....
28908	2658	Presser Foot Spring Guide for 28909.....
28909	2658	" " (left hand spring guide) with 665D and 28908.....
28910	2659	Binder on Shank.....
28920	1387	Presser Foot, for braiding, to stitch braid right hand edge.....
28935	2661	Hemmer on Shank, for bobbinette material, to turn the hem under.....
28938	2658	Presser Foot for 28724.....
28941	2661	Binder (horn) on Shank, for bias binding, to turn under both edges of binding....
28944	2665	Presser Foot (strip folding) for making raw edge straps of bias chiffon.....
28945	2666	Strip Folder on Shank, for making overall straps.....
28947	—	Hemmer for 28948.....

## NUMERICAL LIST OF PARTS

NO.	PLATE	NAME
28948	1386	Hemmer on Shank complete, for one fold, with right hand lower guide for lace, Nos. 26653, 26654 and 28947.....
Nos. 28949 to 28952 FOR 28953		
28949	—	Presser Foot.....
28950	2658	" " Graduated Adjustable Guide
28951	2671	" " " " " "
		Clamping Lever.....
28952	2671	Presser Foot Graduated Adjustable Guide Clamping Lever Spring.....
28953	2658	Presser Foot with Graduated Adjustable Guide complete, for tailor work, Nos. 2653, 26092 and 28949 to 28952.....
28958	2668	Edge Folder and Binder (combination) for seaming ladies' skirts and making imitation plait.....
Nos. 28964 to 28966 FOR 28967		
28964	—	Presser Foot Body.....
28965	2658	" " Knife.....
28966	2658	" " " Clamp.....
28967	2658	Presser Foot complete, for grooving insoles, Nos. 198D, 15072 and 28964 to 28966.....
28969	2669	Guide (adjustable, hinged) complete, Nos. 286D, 940D, 7071, 28971 to 28973 and 35610, obsolete, use 120428.....
28970	2659	Binder on Shank, for bias binding, to turn both edges under.....
28971	2669	Binder Shank for 120165.....
28971	2669	Guide for 28969 and 120428.....
28971	2669	Edge Folder Shank for 36292.....
28972	5839	Binder Arm for 120166.....
28972	5810	Edge Folder Holder for 36293.....
28972	2669	Guide Holder for 28969 and 120428.....
28973	5839	Binder Hinge Plate for 120166.....
28973	5810	Edge Folder Holder Shank for 36293.....
28973	2669	Guide Holder Shank for 28969.....
28974	2661	Piping Attachment on Shank.....
28975	2658	Presser Foot for 28974.....
29549	1353	Tension Releasing Lever for 31-15, 31-16, 31-20, 31-24, 31-27, 31-32, 31-34 and 31-37 Machines, obsolete.....
29599	2014	Arm Oil Tube Packing (felt) for 11119, 12454 and 24131, obsolete.....

## NUMERICAL LIST OF PARTS

NO.	PLATE	NAME
29633	5736	Feed Rock Shaft Crank with 157r, for 20333 and 20334.....
32572	5806	Tension Releasing Disc for 44118.....
32574	5806	" " Pin for 44118.....
33887	8633	Machine Hinge Plate for 44244.....
33892	—	Tension Screw Stud 413c with 1560c, for 44147 and 44149, obsolete.....
Nos. 35002 to 35006 FOR 35137		
35002	2671	Presser Foot Extension.....
35003	2671	" " Graduated Adjustable Guide (long, left).....
35004	2671	Presser Foot Graduated Adjustable Guide (long, right).....
35005	2671	Presser Foot Graduated Adjustable Guide (short, right).....
35006	2671	Presser Foot Graduated Adjustable Guide (short, right) flush.....
35016	—	Hemmer, $\frac{1}{8}$ in. hem, for 26607.....
35018	2045	Tape Delivery Wire for 31-37 Machine (Attachments and Accessories) for 35883
35018	5643	Tubular Trimming Attachment Tape Delivery Wire for 35883.....
35019	984	Ruffler Driving Lever Spring for 26018..
35022	1386	Hemmer on Shank, for $\frac{1}{8}$ in. hem, with right hand lower guide, for lace.....
35023	2672	Hemmer on Shank, for $\frac{1}{8}$ in. hem, with left hand lower guide, for lace.....
Nos. 35026 to 35029 FOR 35030		
35026	2673	Corder on Shank.....
35027	2674	Feed Dog, 15 teeth (14 teeth to the inch)
35028	2674	Presser Foot.....
35029	2674	Throat Plate for 35027.....
35030	—	Corder complete, for edge cording plush, Nos. 35026 to 35029.....
35040	2658	Presser Foot for 28804.....
35062	2676	Binder (horn) on Shank, for $\frac{1}{8}$ in. to $1\frac{1}{2}$ in. wide, for tape, for mattresses.....
35063	2676	Presser Foot for 35062 and 35236.....
35063	2676	" " " light work, for 35104....
35064	2661	Hemmer on Shank, for 1 in. to 2 in. hem, for general work.....
35065	2677	Binder on Shank, for strip, to turn in upper edge only, for skirt facings, etc..
35066	5644	Presser Foot for 35065, 35067, 35208, 35241, 35325, 35681, 35863, 120247 and 120248

## NUMERICAL LIST OF PARTS

NO.	PLATE	NAME
35067	2678	Binder (horn) on Shank, for strip to turn both edges in, for ladies' collars, etc....
35069	2666	Binder (foot) for strip, to turn the upper edge in, for skirt facings, etc.....
35082	2680	Binder on Shank, for raw edge bias binding, for wrappers, etc.....
35104	2684	Hemmer on Shank, for bottom of shirt waists, for inserting drawing or shirring string.....
35129	2682	Presser Foot (strip folding) for covering cord with folded strip.....
Nos. 35134 to 35136 FOR 35137		
35134	2671	Presser Foot.....
35135	2671	" " Graduated Adjustable Guide Clamp.....
35136	2671	Presser Foot Graduated Adjustable Guide Clamp Lever.....
35137	—	Presser Foot with Extension and Graduated Adjustable Guides complete, Nos. 337B, 35002 to 35006, 35134 to 35136 and 36696.....
35166	2694	Hemmer on Shank, for 1 in. hem, to turn the goods under.....
35172	2682	Presser Foot (tube) for guiding and stitching the right hand edge of ribbon.....
35175	2690	Edge Folder on Shank.....
35176	2690	Presser Foot for 35175.....
35177	2691	Edge Folder (double) on Shank, for oil-cloth and leather, for 31-19 Machine...
35178	2692	Feed Dog, 14 teeth (14 teeth to the inch) for 35177.....
35179	2692	Lifting Presser Foot for 35177.....
35180	2692	Throat Plate for 35178.....
35181	2692	Vibrating Presser Foot for 35177.....
35182	2684	Binder on Shank, for cut strip, with heavy cord stitch in centre of strip, for ladies' dressing sacques, etc.....
35183	1252	Presser Foot for 35182.....
35184	2682	" " " darning.....
35189	2697	Feed Dog, 6 teeth (20 teeth to the inch) for 28967.....
35190	2697	Guide for 28967.....
35191	2697	Throat Plate, for under braiding, for 35189
35208	1971	Binder on Shank, to turn in both edges for bias or straight binding, for skirts, wrappers, shirtwaists, etc.....

NO.	PLATE	NAME
35209	1972	Binder on Shank, to turn in both edges for bias binding, for binding the inside of small circles, corsets, etc., for 31-19 Machine.....
35210	1252	Lifting Presser Foot for 35209.....
35211	1252	Vibrating Presser Foot for 35209.....
35226	1972	Binder on Shank, for mattress work.....
35231	1252	Presser Foot for 35226.....
35232	2674	Lifting Presser Foot for 35226 for 31-19 Machine.....
35233	2674	Vibrating Presser Foot for 35226 for 31-19 Machine.....
35236	1971	Hemmer on Shank, for $\frac{1}{8}$ in. hem and above, for bottom of shirt waists.....
35241	2695	Hemmer on Shank, for Canton flannel, etc.
35242	2698	Feed Dog, 12 teeth (18 teeth to the inch) for 35243.....
35243	2698	Presser Foot (strip folding) with tube for inserting cord, for making loops for dressing gowns.....
35244	2698	Throat Plate for 35242.....
35245	2699	Piping Attachment on Shank.....
35246	2699	Presser Foot for 35245.....
35253	2693	Edge Folder (double) on Shank, for joining yokes to the back of shirts.....
35254	2693	Presser Foot for 35253.....
35255	2693	Feed Dog, 14 teeth (16 teeth to the inch) for 35253.....
35256	2693	Throat Plate for 35255.....
Nos. 35272 to 35274 FOR 35280		
35272	2061	Separating Blade Arm.....
35273	2061	" " " Bracket.....
35274	2061	" " " Latch Lever with 35275.....
35275	2061	Separating Blade Arm Latch Lever Stud for 35274.....
35276	2061	Separating Blade Holder for 35280.....
35277	2061	" " " Spring for 35280.....
35279	2062	" " for 35280.....
35280	----	Separating Blade (hinged) complete for 31-27 Machine, Nos. 76D, 108D, 4604, 10135, 14026, 35272 to 35274, 35276, 35277, 35279, two each 102D, 239D and 337D.....

Nos. 35282 to 35286 FOR 35280

NO.	PLATE	NAME
35282	2064	Edge Guide (upper) left hand.....
35283	2062	" Folder (lower) right hand, on Shank
35284	2064	" " (upper) left hand.....
35285	2062	Presser Foot.....
35286	2062	Ruffling Blade.....
35322	2697	Lifting Presser Foot for 35324.....
35323	2697	Vibrating Presser Foot for 35324.....
35324	2684	Strip Folder on Shank, for making four-ply bands for ladies' stock collars, etc., for 31-19 Machine.....
35325	2067	Binder on Shank, to turn top edge only, for shirt bosoms, skirt trimmings, etc....
35345	953	Strip Folder on Shank, for making straps
35346	2669	Presser Foot for 35345.....
Nos. 35347 to 35350 FOR 35351		
35347	970	Strip Folder (double) hinged, for turning in the right hand edges of strips, for making strip, for 35348.....
35348	970	Strip Folder, for turning in the upper and lower edges of strip made on 35347....
35349	970	Strip Folder Holder and Guide.....
35350	8630	Presser Foot.....
35351	----	Attachment complete, for making two piece apron straps, cloth suspenders, etc., Nos. 19474, 24572, 35347 to 35350 and two each 190D and 7071.....
35352	970	Binder Folder on Shank for 35354.....
35353	970	" " Hinge Plate for 35354.....
35353	932	Hemmer Folder Hinge Plate for 35681....
35354	970	Binder on Shank (hinged) complete, for mattress work, Nos. 1425E, 2749, 35352 and 35353.....
35444	----	Presser Foot Body for 35447.....
35445	----	" " Tension Plate with 35446, for 35447.....
35446	2669	Presser Foot Tension Plate Guide Pin for 35445.....
35447	2669	Presser Foot (tension plate) complete for 35354, Nos. 93F, 2656, 35444 and 35445
35454	2616	Presser Foot for 28731.....
35475	976	Hemmer on Shank, for $\frac{3}{8}$ in. hem, with right hand lower guide, for lace.....
35539	2669	Hemmer (foot) $\frac{1}{8}$ in. hem, for China silk, etc.....

NO.	PLATE	NAME
35599	2669	Presser Foot, for etching, for 31-42 Machine.....
35610	2669	Edge Folder Holder Friction Washer for 36293.....
35610	2669	Guide Holder Friction Washer for 28969 and 120428.....
35679	932	Hemmer Folder on Shank for 35681.....
35681	932	Hemmer on Shank (hinged) complete, for mattress work, Nos. 1425D, 35353, 35679 and 36006.....
35682	—	Hemmer (foot) $\frac{1}{8}$ in. hem, with guide on bottom to the right of needle hole.....
35690	1246	Presser Foot (strip folding) for making straps from 1 in. to $1\frac{1}{2}$ in. wide.....
35700	976	Hemmer (left hand) with right hand lower guide on shank, for 31-27 Machine....
35710	1252	Hemmer (foot) $\frac{3}{8}$ in. hem, with guide on bottom to the right of needle hole.....
35711	1252	Feed Dog, 21 teeth (18 teeth to the inch) for 35712.....
35712	1252	Throat Plate, small needle hole, for 35711, for 35682, 35710, 35997 and 36072.....
35741	—	Throat Plate, small needle hole, for 12370, for 26466.....
35832	2669	Presser Foot, for heavy work, for 35104..
35855	1253	Strip Folder on Shank, for collar bands..
35856	2669	Presser Foot for 35855.....
35863	5644	Hemmer on Shank, for canvas work.....
35877	—	Presser Foot (strip folding) for raw edge strip, to turn the edges under, for making $1\frac{1}{8}$ in. to 2 in. strip.....
Nos. 35879 to 35882 FOR 35883		
35879	5643	Tubular Trimming Attachment Strip Wire
35880	5643	Feed Dog, 6 teeth (16 teeth to the inch)
35881	5643	Presser Foot (strip folding) with tube....
35882	5643	Throat Plate for 35880.....
35883	—	Tubular Trimming Attachment complete, for making $\frac{1}{8}$ in., $\frac{3}{8}$ in. and $\frac{1}{4}$ in. trimmings, Nos. 35018 and 35879 to 35882
35922	2619	Ruffling Blade for 28756.....
35995	5645	Presser Foot with right hand folder, for folding and stitching facing to shoe lining.....
35997	—	Hemmer (foot) $\frac{1}{8}$ in. hem, with guide on bottom to the right of needle hole.....

NO.	PLATE	NAME
36006	932	Hemmer Folder Hinge Screw Washer for 35681.....
36022	5645	Presser Foot with 665D and 36023, for blind stitch cording, for 12 to 40 ligne cord, for ornamental cording on skirts, suits, etc.....
36023	5645	Presser Foot Cord Guide for 36022.....
36072	—	Hemmer (foot) $\frac{1}{4}$ in. hem, with guide on bottom to the right of needle hole.....
36085	—	Hemmer (foot) $\frac{1}{8}$ in. hem, slotted for lace
36129	5812	Piping Attachment (double), adjustable on Shank with upper edge folder.....
36131	5812	Presser Foot for 36129.....
36182	5808	" " with 665D and 36183, for blind stitch braiding, for soutache braid
36183	5808	Presser Foot Braid Guide for 36182.....
Nos. 36185 to 36187 FOR 36188		
36185	6252	Edge Guide Arm with 1988.....
36186	6252	" " " Friction Washer.....
36187	6252	" " " Bed with four 465F.....
36188	6252	Edge Guide (roller) complete, for glove work, Nos. 1425D and 36185 to 36187..
36292	5810	Edge Folder (double) on Shank 28971, for 36293.....
36293	5810	Edge Folder (double) hinged, adjustable, complete, Nos. 286D, 940F, 7071, 28972, 28973, 35610 and 36292.....
36294	5810	Presser Foot for 36293.....
36309	—	Hemmer (foot) $\frac{1}{2}$ in. hem, with guide on bottom to the right of needle hole.....
Nos. 36340 to 36343 FOR 36344		
36340	5807	Binder Bed with two each 1036C and 1266C
36341	5807	" " Edge Guide.....
36342	5807	" " Guide (lower).....
36343	5807	" " (upper).....
36344	5807	Binder (adjustable) complete, for leather binding, canvas bags, leggings, etc., Nos. 286D, 671D and 36340 to 36343...
36456	6254	Binder Bed for 36463.....
36457	6254	" Folder with 25669, 36458 and two 7476, for 36463.....
36458	6254	Binder Folder Guide Block for 36457....
Nos. 36459 to 36462 FOR 36463		
36459	6254	Binder Guide (back, lower).....

NO.	PLATE	NAME
36460	6254	Binder Guide (back, upper).....
36461	6254	" " (front, lower).....
36462	6254	" " (front, upper).....
36463	6254	Binder (adjustable) complete, for soft hats Nos. 401E, 1536D, 25672, 25673, 25677, 36456, 36457, 36459 to 36462, two 233D and three 334D.....
36520	—	Hemmer, 1/4 in. hem, for 36521.....
36521	5811	Hemmer on Shank complete, Nos. 26653, 26654 and 36520.....
36524	—	Hemmer (foot) 5/8 in. hem, with guide on bottom to the right of needle hole....
36561	8213	Tucker complete, Nos. 26719, 36655 to 36657, 36660, 36661, 36663, 36667, 120500, 120572 and two each 36658, 50238 and 86354.....
36576	5808	Presser Foot Finger Guard for 36623.....
36578	—	Oiler (copper plated) with 36579 (Attach- ments and Accessories) obsolete, use 120342.....
36579	—	Oiler Spout, 3 1/2 in. long, with 120117, for 36578, obsolete.....
36589	—	Presser Foot for 28700.....
36620	2645	Binder Ribbon Guide for 28794.....
36622	5808	Presser Foot for 36623.....
36623	5808	" " 36622 with 36576 and two 50202D.....
36648	8213	Tucker Tuck Marker Rivet for 36663....
36655	8213	" Driving Lever for 36561.....
36656	8213	" " " Hinge Stud for 36561.....
36657	8213	" " " Lock Spring for 36561.....
36658	8213	Tucker Driving Lever Lock Spring Rivet for 36561.....
36660	8213	Tucker Tuck Guide for 36561.....
36661	8213	" " " Thumb Screw Washer for 36561.....
36662	8213	Tucker Tuck Marker (lower) for 36663....
36663	—	Tucker Tuck Marker (lower) 36662 with 36664 and two 36648, for 36561.....
36664	8213	Tucker Tuck Marker (upper) for 36663....
36667	8213	" " Smoothing Spring for 36561.....
36696	2671	Presser Foot Graduated Adjustable Guide Clamp Steady Pin for 35137.....
36700	5808	Binder (foot) left.....
36711	—	Hemmer, 1/4 in. hem, for 36712.....

NO.	PLATE	NAME
36712	5811	Hemmer on Shank complete, for umbrella work, Nos. 26653, 26654 and 36711....
36760	1375	Edge Guide Slide with 26809, 51809 and two 12152, for 26810.....
36776	—	Hemmer on Shank, 2 1/4 in. to 3 in. hem..  Nos. 36818 to 36820 FOR 36821
36818	5809	Finger Guard.....
36819	5809	" " Friction Washer.....
36820	5809	" " Holder with 1961.....
36821	5809	Finger Guard complete, Nos. 36818 to 36820 and 503161.....
36906	5813	Throat Plate with under guide, for rick rack, for 19474.....
Nos. 36980 TO 36983 FOR 12437 AND 20147		
36980	—	Hemmer (foot) 3/8 in. hem.....
36981	—	" " 3/8 in. hem.....
36982	—	" " 1/8 in. hem.....
36983	—	" " 1/4 in. hem.....
39395	5839	" Block Pin for 120073.....
41400	6120	Machine Rest Pin (wood) 3 1/8 in. long, (Attachments and Accessories).....
41514	2836	Thread Unwinder Spool Weight, 4 in. diam., with 41515, for 41529 and 41533
41515	5742	Thread Unwinder Spool Weight Centre Pin for 41514.....
41526	2836	Thread Unwinder Spool Rest for 60701..
41527	—	" " " " 60701 with 27623, for 41529.....
41529	2836	Thread Unwinder complete, for one large spool or one large cone of thread, Nos. 27739, 27940, 41514, 41527, 41630, 41640 and three wood screws 1 in. No. 12, obsolete, use 225394.....
41530	2837	Thread Unwinder Spool Rest for 60455..
41531	—	" " " " 60455 with two 27623, for 41533.....
41533	2837	Thread Unwinder complete, for two large spools or two large cones of thread, Nos. 27940, 41531, 41631, 41640, two each 27739, 41514 and three wood screws 1 in. No. 12, obsolete, use 225396.....
41569	5842	Thread Unwinder Thread Guard Eyelet for 41630 and 41631.....
41630	2836	Thread Unwinder Thread Guard with 208E and 41569, for 41529.....

## NUMERICAL LIST OF PARTS

NO.	PLATE	NAME
41631	2837	Thread Unwinder Thread Guard with 208E and two 41569, for 41533.....
Nos. 41637 to 41639 FOR 41640		
41637	2836	Thread Unwinder Thread Guard Rod (lower).....
41638	2836	Thread Unwinder Thread Guard Rod (upper).....
41639	2836	Thread Unwinder Thread Guard Rod Coupling with two 456c.....
41640	—	Thread Unwinder Thread Guard Rod complete, 30 in. long, for 41529 and 41533, Nos. 41637 to 41639.....
41828	—	Bobbin Winder Spindle Collar Pin for 27538.....
41929	5844	Belt Guard for 41931.....
41930	5842	" " Hinge for 41931.....
41931	—	Belt Guard complete, Nos. 8420, 41929, two 41930 and four wood screws ¼ in. No. 9.....
43525	8631	Binder Steady Pin for 120540.....
Nos. 43801 to 43818 FOR 31-42 MACHINE		
*43801	—	Arm with 11104.....
43802	5735	" Shaft for 44112.....
43803	5738	Needle Bar Crank and Lifting Cam with 448c and 1362c, for 44112.....
43804	5740	Presser Bar Stop Collar with 1253c.....
43805	5742	" Foot, obsolete.....
43806	—	Stop Wheel with 2269, for 43807, obsolete
43807	5735	Stop Wheel complete, Nos. 446c, 12316, 12325, 12345, 43806 and two 840D, obsolete, use 43943.....
43808	5741	Thread Retainer Spring for 43809.....
43809	—	Thread Retainer complete, Nos. 418D, 1562r, 43808 and two 2455.....
43810	5760	Starting Treadle Extension for 43815....
43811	5760	" " Pitman Rod (lower) for 43814.....
43812	5760	Starting Treadle Pitman Rod (upper) for 43814.....
43813	5741	Starting Treadle Pitman Rod Clamp with 354c, for 12439 and 43814.....
43814	—	Starting Treadle Pitman complete for 43816, Nos. 12283, 12317 and 43811 to 43813.....

## NUMERICAL LIST OF PARTS

NO.	PLATE	NAME
43815	—	Starting Treadle complete for 42816, Nos. 326E, 2878, 9082, 27636, 43810, 51075E, two 6055 and four wood screws 1 in. No. 16.....
43816	—	Starting Treadle and Pitman complete, Nos. 11742, 25089, 43814 and 43815 for 31-42 Machine when operated head on .
43817	5741	Presser Foot.....
43818	5739	Driving Pulley Spring Washer.....
Nos. 43830 to 43834 FOR 31-37 MACHINE		
43830	5784	Plaiting Cam No. 10.....
43831	5784	" " " 11.....
43886	5738	Finger Protector for 31-39 Machine.....
Nos. 43887 to 43890 FOR 31-37 MACHINE		
43887	5745	Plaiting Blade Holder (lower) Hinge Stud
43887	5745	" " " (upper) Hinge Stud
43888	5745	" " " (lower) Spring Stop
43888	5745	" " " (upper) Spring Stop
43889	5752	" Rock Shaft.....
43890	5755	Edge Guide.....
43917	2009	Presser Bar Guide Bracket with 453c, for 31-22 Machine.....
43918	5757	Ruffling Separating Blade for 43920.....
43919	5757	" " " Shank for 43920
43920	5757	Ruffling Separating Blade on Shank complete for 31-27 Machine, Nos. 43918, 43919 and two 26092.....
43923	5743	Feed Dog, 12 teeth (12 teeth to the inch) for 31-34 Machine.....
43924	5757	Feed Forked Connection for 44188.....
43925	780	Presser Foot for 43923.....
43926	5743	Throat Plate for 43923.....
*43927	—	Arm with 11104, for 31-35 Machine.....
43928	—	Foot Lifter complete for 31-19 Machine, Nos. 76D, 766D, 802D, 1521E, 4380, 4385, 5598, 5670, 12415, 12416, 19372, 20340, 21301 and two 178E.....
43929	—	Foot Lifter complete for 31-35 Machine, Nos. 76D, 766D, 802D, 1521E, 4380, 4385, 5598, 5670, 12241, 12415, 12416, 16586, 20340 and two 178E.....

## NUMERICAL LIST OF PARTS

NO.	PLATE	NAME
43930	—	Knee Lifter complete (power table or stand 25265) for 31-35 Machine, Nos. 76d, 766d, 802d, 1521E, 5598, 12241, 12250, 12415, 12416, 16586, 20340 and two 178E
43931	—	Knee Lifter complete (Stands 25255 and 25265) for 31-19 Machine, Nos. 76d, 766d, 802d, 1521E, 5598, 12415, 12416, 19372, 20340, 20465, 21301 and two 178E
43933	—	Knee Lifter complete (Stand 25255) for 31-24 Machine, Nos. 76d, 766d, 802d, 1521E, 5598, 12237, 12240, 12241, 12416, 20255, 20465 and two 178E
43934	—	Knee Lifter complete (Stand 25255) for 31-35 Machine, Nos. 76d, 766d, 802d, 1521E, 5598, 12241, 12415, 12416, 16586, 20340, 20465 and two 178E
43941	—	Stop Wheel with 2269, for 43943
43942	5738	“ “ Block for 43943
43943	5735	Stop Wheel complete for 31-42 Machine, Nos. 446c, 12316, 12345, 43941, 43942 and two 840d
43944	5806	Tension Releasing Lever for 31-15, 31-16, 31-19, 31-20, 31-24, 31-27, 31-32, 31-34, 31-35, 31-37 and 31-39 Machines
43945	5806	Tension Spring for 44118
43946	5806	Thread Take-up Spring for 44118
43947	5736	“ “ Crank for 43991
43976	5804	Feed Lifting Rock Shaft Crank Connecting Rod with 43977 and two 966E, for 31-15, 31-16, 31-19, 31-20, 31-22, 31-24, 31-27, 31-32, 31-34, 31-35 and 31-37 Machines
*43977	—	Feed Lifting Rock Shaft Crank Connecting Rod Cap for 43976
43978	778	Feed Dog, 24 teeth (22 teeth to the inch) for 31-15, 31-16 and 31-20 Machines
43979	778	Feed Dog, for cloth, 21 teeth (22 teeth to the inch) for 31-15, 31-19 and 31-20 Machines
43980	5837	Tension Releasing Lever for 31-22 Machine
43981	6119	Bobbin Winder Frame for 43982 and 43983
43982	6119	Bobbin Winder Frame complete for 12337, Nos. 5960, 5961, 5963, 12336, 15077 and 43981

## NUMERICAL LIST OF PARTS

NO.	PLATE	NAME
43983	6119	Bobbin Winder Frame complete for 20498, Nos. 5960, 5961, 5963, 12336, 15077 and 43981
43990	—	Thread Take-up complete for 31-15, 31-16, 31-19, 31-20, 31-24, 31-27, 31-32, 31-34, 31-35, 31-37 and 31-39 Machines, Nos. 775E, 11204, 12404, 12410 and 43997
43991	—	Thread Take-up complete for 31-22 Machine, Nos. 775E, 11204, 12410, 43947 and 43997
43992	—	Feed Forked Connection complete for 31-32 Machine, Nos. 3033, 12332, 44003 and two each 375c and 1518j
43993	—	Feed Forked Connection complete for 31-15, 31-16, 31-19, 31-20, 31-24, 31-27, 31-35 and 31-37 Machines, Nos. 818d, 3033, 3039, 20284 and two each 375c and 1518j
43997	—	Needle Bar Connecting Link 12382 with 12384, for 43990 and 43991
44003	5840	Feed Forked Connection for 43992 Nos. 44004 to 44006 for 44007
44004	2565	Oil Cup, obsolete
44005	2565	“ “ Extension 44214 with 24075, for 44007 and 44223
44006	2565	Oil Cup Packing (felt) for 44007 and 44225
44007	2565	Oil Cup complete for 31-16 Machine, Nos. 44004 to 44006, obsolete, use 44225
44008	—	Needle Bar Connecting Link 12196 with 12131, for 44179
44009	5840	Slack Thread Regulator for 31-27 Machine
*44010	—	Arm with 11104, for 31-39 Machine
44112	—	“ Shaft 43802 with 43803, for 44200
44118	—	Tension complete, Nos. 7336, 32572, 32574, 43945, 43946, 44141 and two 2102
44121	—	Arm Shaft 12427 with 20283, 24036 and 62637, for 44195
44122	—	Arm Shaft 12427 with 20188, 20283 and 24036, for 44189
44123	—	Arm Shaft 12427 with 16569, 20283 and 24036, for 44196
44124	—	Arm Shaft 12427 with 12197 and 20188, for 44197
44125	5804	Feed Lifting Rock Shaft for 44126

NO.	PLATE	NAME
44126	—	Feed Lifting Rock Shaft complete for 31-15, 31-16, 31-19, 31-20, 31-22, 31-24, 31-27, 31-32, 31-34, 31-35 and 31-37 Machines, Nos. 12376 and 44125.....
44130	—	Arm Shaft 20332 with 20188, 20283, 24036, 24207 and 24208, for 44207.....
44134	—	Oscillating Shaft Crank for 44135.....
44135	5806	Oscillating Shaft Crank complete, Nos. 1518j, 19449, 44134 and two 453c.....
44136	1381	Feed Dog, 15 teeth (16 teeth to the inch) for tailor work, for 31-15, 31-20 and 31-22 Machines.....
44137	1381	Throat Plate, large needle hole, for 44136
44138	—	“ “ small needle hole, for 44136
44139	772	Machine Hinge Plate for 44140 and 44180
44140	—	Machine Hinge complete, Nos. 12361, 44139 and merlized wood screw 1¼ in. No. 14 (Attachments and Accessories)
44141	—	Tension Screw Stud 50327c with 1560c, for 44118.....
44144	1262	Feed Dog, 22 teeth (24 teeth to the inch) for shirt work, beveled for hemmer, for 31-20 Machine.....
44147	—	Tension complete for 31-19 and 31-42 Machines, Nos. 2923, 7336, 8511, 20037, 33892 and two 2921, obsolete.....
44149	—	Tension complete, for 31-39 Machine, Nos. 2923, 7336, 8511, 33892 and two 2102, obsolete.....
44156	5837	Feed Dog, for shirt work, 24 teeth (24 teeth to the inch) for 31-20 Machine..
44158	5842	Feed Dog, 15 teeth (14 teeth to the inch)
44159	—	Presser Foot Plate for 44161.....
44160	—	“ “ Shank for 44161.....
44161	5842	Presser Foot (hinged) complete, Nos. 26276, 44159 and 44160.....
44162	5842	Throat Plate for 44158.....
*44169	—	Arm Shaft 20400 with 20188, 20283, 20426 and 24036, for 44199.....
*44172	—	Arm Shaft 12427 with 20188, for 44192...
*44176	—	Driving Attachment Starting Crank Shaft 12477 with 12479, 20371 and two 2022, for 12478 and 20141.....
44177	1260	Feed Dog, for shirt work, 19 teeth (22 teeth to the inch) for 31-20 Machine..

NO.	PLATE	NAME
44179	—	Thread Take-up Lever complete for 31-42 Machine, Nos. 775E, 11204, 12130, 12164 and 44008.....
44180	—	Machine Hinge complete, Nos. 6055, 12361, 44139 and 51075E (Attachments and Accessories).....
*44181	—	Face Plate Thread Guard (lower) for 12150
44188	—	Feed Forked Connection 43924 with 818D, 3033, 3039 and two each 375c and 1518j, for 31-34 Machine.....
*44189	—	Arm Shaft 44122 with 20197, for 31-15, 31-16, 31-20, 31-22 and 31-24 Machines
*44192	—	Arm Shaft 44172 with 20197, for 31-39 Machine.....
*44195	—	Arm Shaft 44121 with 20197, for 31-19 Machine.....
*44196	—	Arm Shaft 44123 with 20197, for 31-35 Machine.....
*44197	—	Arm Shaft 44124 with 20197, for 31-32 Machine.....
*44199	—	Arm Shaft 44169 with 20197, for 31-37 Machine.....
*44200	—	Arm Shaft 44112 with 20197, for 31-42 Machine.....
*44207	—	Arm Shaft 44130 with 20197, for 31-27 Machine.....
44212	5844	Drip Pan with four 1 in. wire nails, for power table.....
44214	—	Oil Cup Extension for 44005.....
*44217	—	Arm Shaft 12427 with 12428, 20188 and 20197, for 31-34 Machine.....
44222	—	Oil Cup for 44223.....
44223	—	“ “ 44222 with 44005, for 44225.....
44224	8628	“ “ Thread Retainer for 44225.....
44225	8628	Oil Cup complete for 31-16 Machine, Nos. 44006, 44223 and 44224.....
44226	8629	Feed Bar for 31-34 Machine.....
44228	8629	Stop Pawl for 44230.....
44229	8628	“ “ Wearing Block for 44230.....
44230	—	Stop Pawl complete for 12344, Nos. 376E, 44228 and 44229.....
44243	8633	Machine Hinge Connection for 44244....
44244	—	Machine Hinge complete for 79758, Nos. 2809, 33887, 44243 and merlized wood screw 1¼ in. No. 14.....



NO.	PLATE	NAME
44252	5813	Feed Dog, for cloth, 12 teeth (12 teeth to the inch) for 31-15, 31-19, 31-20 and 31-22 Machines, 28654, 28657 and 36293
44253	5813	Feed Dog, for cloth, 16 teeth (16 teeth to the inch) for 31-15, 31-19, 31-20 and 31-22 Machines, 26760, 28654, 28657 and 35245.
44254	5813	Feed Dog (reversible) for cloth, 12 teeth (12 teeth to the inch) for 31-32 Machine
44255	5813	Throat Plate, small needle hole, for 44252 to 44254.
44256	—	Throat Plate, large needle hole, for 44252 to 44254.
Nos. 46506 to 46509 FOR 46520 AND 46656		
46506	3826	Pitman Ball Bearing Adjusting Screw Ring.
46507	3826	Pitman Ball Bearing Adjusting Screw Ring Locking Washer (brass).
46508	3826	Pitman Ball Bearing Ring.
46509	3826	" " Case.
46519	3825	Band Wheel Crank for 46520 and 46656.
*46520	—	Band Wheel Crank and Pitman (ball bearing) complete for 25265, Nos. 1520R, 25371, 46506 to 46509, 46519, 46523, 46630, 46655 and six 25362.
*46522	3825	Leg for 25265, 25279 and 25284, obsolete
46523	3825	Pitman Rod with 25360, for 46520.
46524	3825	Treadle for 25265 and 25284.
46528	6142	Brace Section (left) with 46629, for 46662
*46604	—	Band Wheel Shaft Driving Flange (left) complete for 25255, Nos. 25422 to 25425, 25429 and 25434.
*46605	—	Band Wheel Shaft Driving Flange (right) complete for 25255, Nos. 25425 to 25429 and 25434.
46629	—	Band Wheel Crank Screw Centre 297c with 1507R, for 46528 and 82985.
46629	—	Treadle Screw Centre 297c with 1507R, for 46663 and 82985.
46630	—	Pitman Rod Ball Screw Bearing 25361 with 1670R, for 46520.
46630	—	Pitman Rod (lower) Ball Screw Bearing 25361 with 1670R, for 46656.
46655	3826	Pitman Ball Separator for 46520 and 46656

NO.	PLATE	NAME
46656	—	Band Wheel Crank and Pitman (ball bearing) complete for 25284, Nos. 1520R, 25371, 46506 to 46509, 46519, 46630, 46655, 46658 to 46660 and six 25362.
46657	—	Belt, size ¼ in., length 36½ in., with 25127, from motor to machine for 25284.
Nos. 46658 to 46660 FOR 46656		
46658	5843	Pitman Rod (lower) with 25360.
46659	5841	" " (upper).
46660	5843	" " Coupling.
46661	—	Starting Treadle Screw Centre 296c with 1507R, for 20040.
46662	6142	Brace (sectional) complete for 25265, 25279 and 25284, Nos. 46528, 46663 and three 880R.
46663	6142	Brace Section (right) with two 46629, for 46662.
46667	—	Brace for 82985.
46681	8497	Driving Attachment Treadle Bracket (right) for 60502.
50035E	5745	Plaiting Blade Holder (lower) Spring Stop Screw for 31-37 Machine.
50035E	5745	Plaiting Blade Holder (upper) Spring Stop Screw for 31-37 Machine.
50169D	5839	Hemmer Guide Screw for 120078.
50202D	5808	Presser Foot Finger Guard Screw for 36623.
50216E	8628	Shuttle Race Slide Spring Screw for 20450
50238B	8213	Tucker Tuck Guide Thumb Screw for 36561.
50238B	8213	Tucker Tuck Marker Clamping Plate Thumb Screw for 36561.
50302J	5809	Finger Guard Holder Set Screw for 120497
50316J	5809	" " Hinge Screw for 36821.
50327C	5806	Tension Screw Stud for 44141.
50356D	5806	Bobbin Winder Frame Hinge Screw for 27647, 27650, 27651 and 27875.
50441D	5839	Hemmer Block Hinge Screw for 120078.
50551J	8628	Belt Guard Set Screw for 126365.
51022J	8630	Binder Screw for 120493.
51075E	5843	Machine Hinge Bolt with 51581E, for 44180.
51097J	8631	Binder Thumb Screw for 120533.
51097J	8631	Tape Reel Arm Thumb Screw for 120533.
51581E	5843	Machine Hinge Bolt Nut for 51075E.

NO.	PLATE	NAME
51809	1375	Edge Guide Slide Roller and Stud for 36760.....
52045	8628	Arm Oil Tube Packing (braided cotton) for 11119, 12454 and 24131.....
52454	5842	Thread Retainer for 31-15, 31-16, 31-19, 31-20, 31-22, 31-24, 31-27, 31-32, 31-34, 31-35, 31-37 and 31-39 Machines.....
56813	—	Feed Bar Screw Centre 313c, with 1519j, for 31-15, 31-16, 31-19, 31-20, 31-22, 31-24, 31-27, 31-32, 31-34, 31-35 and 31-37 Machines.....
56814	—	Feed Lifting Rock Shaft Screw Centre 307c with 1513j, for 31-15, 31-16, 31-19, 31-20, 31-22, 31-24, 31-27, 31-32, 31-34, 31-35 and 31-37 Machines.....
56814	—	Feed Rock Shaft Screw Centre 307c with 1513j, for 31-15, 31-16, 31-19, 31-20, 31-22, 31-24, 31-27, 31-32, 31-34, 31-35 and 31-37 Machines.....
56848	—	Bell Crank 5596 with 5599 and 5601, for 5598.....
60455	—	Thread Unwinder Spool Rest 41530 with 1149c and two 155c, for 41531.....
60502	—	Driving Attachment Treadle Bracket (right) 46681 with two wood screws 1 in. No. 14, for 126209.....
*60583	—	Knife Grinder for 27661, Nos. 261j, 27323, 27564, 27572, 27573, 27659, 60934, two 27568 and four each 310k and 1516j...
60701	—	Thread Unwinder Spool Rest 41526 with 155c and 1149c, for 41527.....
60934	—	Knife Grinder Emery Wheel Shaft 27567 with 1508j, 27565, 27569 and 27822, for 60583.....
62502	—	Shuttle Race Body 24413 with 24418 and two 1053b, for 24419.....
62527	5806	Presser Foot Hinge Pin for 20157, 20311, 20346, 24489, 24546, 24983 and 28814
62623	—	Shuttle Race Body 24008 with 24009 and two 1053b, for 24010, obsolete.....
62637	—	Lifting Presser Bar Bell Crank Driving Arm Eccentric Connection 19362 with 19365, for 44121.....
62682	8628	Face Plate Thread Eyelet for 31-35 Machine.....
62739	—	Shuttle Bobbin Case for 62740.....

NO.	PLATE	NAME
62740	771	Shuttle Bobbin Case complete for 12487 and 19292, Nos. 591f, 592e, 2523, 2975, 7553, 15141, 15278 and 62739.....
67086	5844	Treadle Pitman Rod (upper) for 67177..
67175	5843	Hook for 67072.....
67176	5844	Treadle Pitman Rod (lower) for 67177...
67177	5844	Treadle Pitman complete for S. D. 11 and S. D. 12 Electric Motors, for 25284, Nos. 9079, 67086 and 67176.....
79758	—	Bench Stand with 12248, two each 44244, wood screws $\frac{3}{4}$ in. No. 10, three wood screws $1\frac{1}{2}$ in. No. 10 R. H. O. and A. and four each 12405 and 28084.....
82973	5216	Leg for 25265, 25279 and 25284.....
82985	5216	Brace 46667 with three 46629, for 25265, 25279 and 25284.....
86354	8213	Tucker Tuck Smoothing Spring Rivet for 36561.....
120001	5838	Feed Dog, (spiked teeth) 12 teeth (10 teeth to the inch) for 28678, 28731, 35226, 35354 and 120207.....
Nos. 120073 TO 120077 FOR 120078		
120073	—	Hemmer Block with 39395.....
120074	—	" " Spring.....
120075	—	" Guide.....
120076	—	Hemmer Plate.....
120077	—	" Shank.....
120078	5839	Hemmer (foot) adjustable, complete, for tennis shoes, Nos. 219b, 651b, 50169b, 50441b and 120073 to 120077.....
120117	—	Oiler Spout Washer (leather) for 36579, obsolete.....
120120	5838	Binder Folder with 665b and 120121, for 120127.....
120121	5838	Binder Folder Guide for 120120.....
120122	5838	" Ribbon Tension Plate for 120123
Nos. 120123 TO 120126 FOR 120127		
120123	5838	Binder Ribbon Tension complete, Nos. 26614, 120122 and six 26615.....
120124	5838	Feed Dog, 6 teeth (16 teeth to the inch)..
120125	5838	Presser Foot.....
120126	5838	Throat Plate for 120124.....
120127	—	Binder (English) complete for 31-15 Machine, Nos. 220b, 7806, 120120, 120123 to 120126 and two each 190b and 7071

NO.	PLATE	NAME
120135	5846	Edge Folder (double) for turning in two edges and inserting loops in one operation. ....
120136	5846	Presser Foot for 120135. ....
120143	—	“ “ Plate for 120144. ....
120144	5847	Presser Foot (hinged) complete for 35065, 35067, 35208, 35241, 35325, 120247 and 120248, Nos. 7298, 19335 and 120143. .
120165	5839	Binder on 28971, for 120166. ....
120166	5839	Binder (adjustable) complete, for sleeve facings on military coats, Nos. 286D, 940D, 7071, 28972, 28973 and 120165. .
120191	5845	Strip Folder on Shank, to turn in both edges. ....
120197	5848	Edge Folder (upper) with lower right hand guide on shank, for military uniforms. .
120206	5839	Corder Cord Guide Bed with 457c, for 120207. ....
120207	5839	Corder (adjustable) complete, for short turns on cushions, Nos. 190D, 1044D, 26795, 26796 and 120206. ....
120208	5838	Presser Foot (grooved) for 120207. ....
120242	7790	Binder Bed with 1036c, for 120247 and 120248. ....
120243	7791	Binder Folder (lower) for 120248. ....
120244	7790	“ “ (upper) for 120247 and 120248. ....
120245	7790	Binder Guide (centre) for 120247 and 120248. ....
120246	7790	Binder Guide (lower) for 120247. ....
120247	7790	Binder (adjustable) complete, to turn in upper edge only, for light or medium weight material, Nos. 286D, 120242 and 120244 to 120246. ....
120248	7791	Binder (adjustable) complete, to turn in both edges, for light or medium weight material, Nos. 286D and 120242 to 120245
120257	5847	Binder with tension slots on shank, for turning in both edges of bias cut binding, for light or medium weight material. .
120287	2613	Hemmer for 28720. ....
120288	2613	“ Shank for 28720. ....
120289	2694	“ on Shank, 2 in. hem, to turn the goods under. ....
120325	8627	Hemmer (foot) $\frac{1}{16}$ in. hem, with guide on bottom to the right of needle hole. ....

NO.	PLATE	NAME
120327	8210	Hemmer on Shank, for $\frac{1}{8}$ in. to $\frac{3}{8}$ in. hem for bottom of shirt waists. ....
120338	8625	Hemmer for 120340. ....
120339	8625	“ Shank for 120340. ....
120340	8625	Hemmer on Shank complete, for $\frac{1}{2}$ in. to 2 in. hem, Nos. 120338, 120339 and two 1443J. ....
120342	2045	Oiler (copper plated) with 120343 (Attachments and Accessories). ....
120343	2045	Oiler Spout, 3 $\frac{1}{2}$ in. long, for 120342. ....
120367	8630	Hemmer on Shank, for handkerchief work
120427	8211	Guide Holder Shank for 120428. ....
120428	8211	Guide (adjustable, hinged) complete, Nos. 286D, 940D, 7071, 28971, 28972, 35610 and 120427. ....
120433	8211	Binder Folder for 120437, 120459 and 120467. ....
120434	8211	Feed Dog, 7 teeth (16 teeth to the inch) for 120437, 120459 and 120467. ....
120435	8211	Presser Foot for 120437. ....
120436	8211	Throat Plate for 120434 for 120437, 120459 and 120467. ....
120437	—	Binder (English) complete, for awnings, Nos. 190D, 207F, 25722, 120433 to 120436 and two 7071. ....
120452	2672	Hemmer on Shank, for $\frac{1}{4}$ in. to $\frac{1}{8}$ in. gauges, for Windsor ties. ....
120458	8211	Presser Foot for 120459. ....
120459	—	Binder (English) complete, for slip covers and general work, Nos. 190D, 207F, 25722, 120433, 120434, 120436, 120458 and two 7071. ....
120465	8630	Lifting Presser Foot for 120467. ....
120466	8630	Vibrating Presser Foot for 120467. ....
120467	—	Binder (English) complete, for circular binding on imitation leather, for 31-19 Machine, Nos. 207F, 7071, 120433, 120434, 120436, 120465 and 120466. ....
120479	8212	Quilter Guide (left) for 120485. ....
120480	8212	“ “ (right) for 120485. ....
120481	8212	“ “ Bracket for 120485. ....
120482	—	“ “ “ 120481 with 120483 and two 209c, for 120485. ....
120483	8212	Quilter Guide Disengaging Sleeve for 120482. ....
120484	8212	Quilter Guide Disengaging Sleeve Spring for 120485. ....

NO.	PLATE	NAME
120485	—	Quilter complete, Nos. 602D, 120479, 120480, 120482 and 120484.....
Nos. 120493 to 120495 FOR 28794		
120493	8630	Folder with two 51022J, for ¼ in. to ½ in. gauges.....
120494	8630	Folder with two 1368J, for ⅜ in. to ⅝ in. gauges.....
120495	8630	Folder with two 1368J, for ⅝ in. to 1 in. gauges.....
120496	5809	Finger Guard for 120498.....
120497	5809	“ “ Holder with 50302J, for 120498.....
120498	5809	Finger Guard complete, Nos. 236J, 120496 and 120497.....
120500	8213	Tucker Frame for 36561.....
120532	8631	Binder (transverse) on Shank for 120533
120533	—	Binder (transverse) on Shank with Tape Reel complete, for woolen coats, Nos. 3146, 26603, 120532, 120534 to 120536, 120540 and two 51097J.....
120534	8631	Presser Foot for 120533.....
120535	8632	Tape Reel Arm with 11656 and 120537, for 120533.....
120536	8632	Tape Reel Disc with 120538 and 120539, for 120533.....
120537	8632	Tape Reel Disc Pin for 120535.....
120538	8632	“ “ “ Stud (wood) for 120536..
120539	—	“ “ “ “ Sleeve for 120536..
120540	8631	Throat Plate with 43525, for 26603, for 120533.....
120572	8213	Tucker Tuck Marker Clamping Plate for 36561.....
126036	8497	Driving Attachment Treadle for 126209
126205	8629	Driving Attachment Treadle Bracket (left) for 126206.....
126206	8629	Driving Attachment Treadle Bracket (left) complete for 126209, Nos. 23258, 126205, 126207, 126208 and two wood screws 1 in. No. 14.....
126207	8629	Driving Attachment Treadle Bracket (left) Hook for 126206.....
126208	8633	Driving Attachment Treadle Bracket (left) Hook Rivet for 126206.....
126209	—	Driving Attachment Treadle complete for 126213, Nos. 60502, 126036 and 126206

NO.	PLATE	NAME
126213	—	Driving Attachment Treadle and Pitman complete for 12478 and 20141, Nos. 14233 and 126209.....
126356	5763	Belt Guard for 126365.....
126363	8629	“ “ Bracket for 126365.....
126364	8629	“ “ Extension for 126365.....
126365	—	Belt Guard (adjustable) complete for 79758 Nos. 162D, 1480D, 9331, 50551J, 126356, 126363, 126364 and two wood screws 1 in. No. 10.....
126392	8632	Knife Grinder Knife Holder for 126393..
126393	—	Knife Grinder Knife Holder complete, for 27661, Nos. 227J, 899J, 27660, 126392 and 126394.....
126394	8633	Knife Grinder Knife Stop for 126393.....
200056E	3471	Bobbin Winder Stop Latch Screw for 225382.....
200082D	3471	Bobbin Winder Tension Bracket Screw for 225382.....
200105C	—	Bobbin Winder Pulley Set Screw for 202473
200299H	3471	Bobbin Winder Stop Latch Trip Lever Hinge Screw for 225382.....
200383C	8633	Thread Unwinder Spool Rest Rod Set Screw for 202490.....
201018C	8633	Thread Unwinder Spool Rest Set Screw for 225389 and 225395.....
201499B	3471	Bobbin Winder Tension Stud for 225461.
201572B	3471	“ “ “ “ T h u m b Nut for 225462.....
201696J	8633	Thread Unwinder Thread Guide Lock Nut for 225394 and 225396.....
202277	3471	Bobbin Winder Frame Oil Packing (wick) for 225453.....
202407	3471	Bobbin Winder Tension Spring for 225462
202473	3470	“ “ Pulley with 200105C, for 225382.....
202478	3471	Bobbin Winder Step Latch Trip Lever for 225382.....
202490	8523	Thread Unwinder Spool Stand with 200383C, for 225394 and 225396.....
225381	—	Bobbin Winder Spindle for 225382.....

NO.	PLATE	NAME
225382	3469	Bobbin Winder (swinging automatic, right hand) complete for 2996, 19131 and 24051, for power table, Nos. 200056E, 200082D, 200299H, 202473, 202478, 225381, 225433, 225444, 225453 to 225456, 225458 to 225460, 225462, 228026 and two wood screws 3/4 in. No. 13 R. H. B.....
225388	8523	Thread Unwinder Spool Rest Rod for 225394 and 225396.....
225389	8523	Thread Unwinder Spool Rest with 201018c, for 225394.....
225390	8520	Thread Unwinder Thread Cone Holder, for inverted cones.....
225391	8523	Thread Unwinder Thread Guide for 225394 and 225396.....
225392	8523	Thread Unwinder Thread Guide Rod with 208E and 225393, for 225394 and 225396
225393	8633	Thread Unwinder Thread Guide Rod Washer for 225392.....
225394	8523	Thread Unwinder complete, for one large spool or one large cone of thread, Nos. 201696J, 202490, 225388, 225389, 225391, 225392 and three wood screws 7/8 in. No. 12.....
225395	7233	Thread Unwinder Spool Rest with 201018c, for 225396.....
225396	7233	Thread Unwinder complete, for two large spools or two large cones of thread, Nos. 201696J, 202490, 225388, 225392, 225395, two 225391 and three wood screws 7/8 in. No. 12.....
225433	3469	Bobbin Winder and Tension Bracket Base for 225382.....
225438	3471	Bobbin Winder Frame Oil Well Cap for 225453.....
225444	3471	Bobbin Winder Stop Latch for 225382...

Nos. 225453 to 225456 FOR 225382

225453	3470	Bobbin Winder Frame with 202277 and 225438.....
225454	3471	Bobbin Winder Frame Hinge Pin.....
225455	3471	" " " Spring.....
225456	3471	" " " " Plunger...

Nos. 225458 to 225460 FOR 225382

NO.	PLATE	NAME
225458	3471	Bobbin Winder Stop Latch Thumb Lever
225459	3471	" " " " " "
		Hinge Stud.....
225460	3471	Bobbin Winder Stop Latch Thumb Lever Joint Stud.....
225461	3471	Bobbin Winder Tension Bracket with 201499B, for 225462.....
225462	—	Bobbin Winder Tension Bracket complete for 225382, Nos. 201572B, 202407, 225461 and two 2102.....
228026	—	Bobbin Winder Tension Bracket Screw Washer for 225382.....

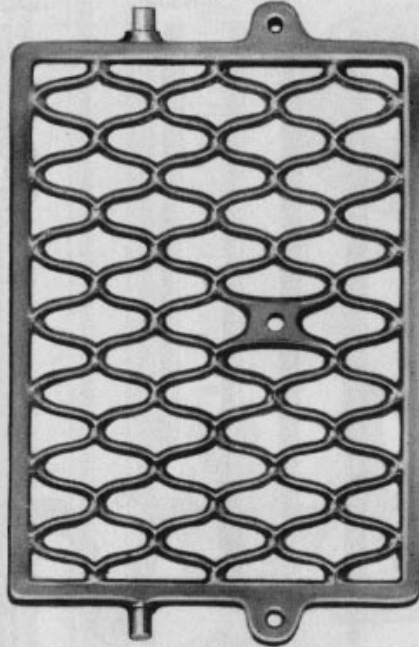
**SINGER** Needles should be used  
 in **SINGER** Machines  
 These Needles and their Containers  
 are marked with the  
 Company's Trade Mark "**SIMANCO.\*\***" 1

Needles in Containers marked  
 "**FOR SINGER MACHINES**"  
 are **NOT SINGER** made needles. 2

PLATE 363—ONE-FOURTH SIZE

27636

27474



2878



27070

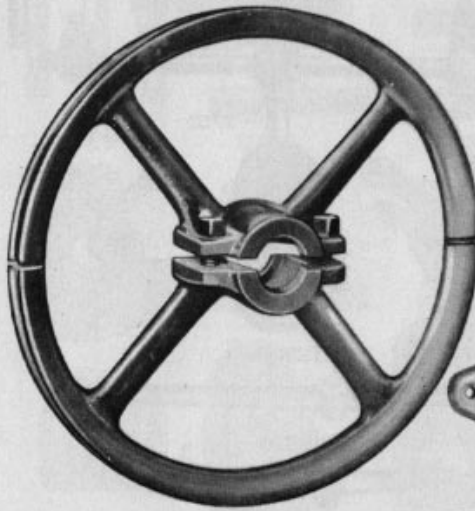


PLATE 766—ONE-FOURTH SIZE

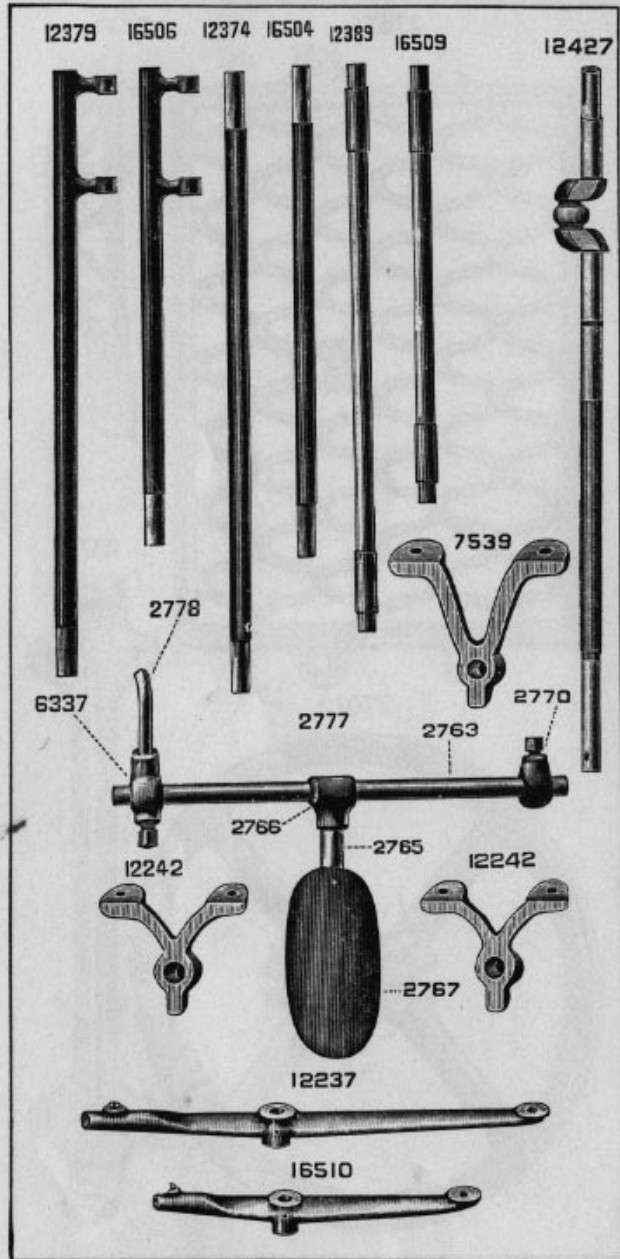


PLATE 767—ONE-HALF SIZE

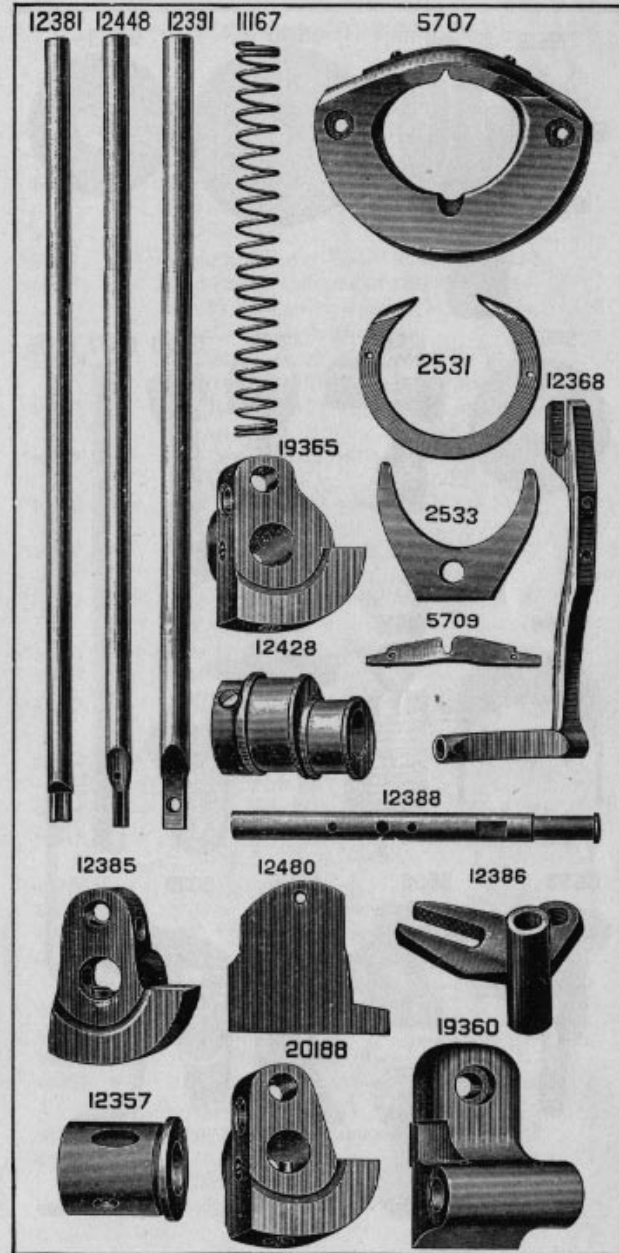


PLATE 768—ONE-HALF SIZE

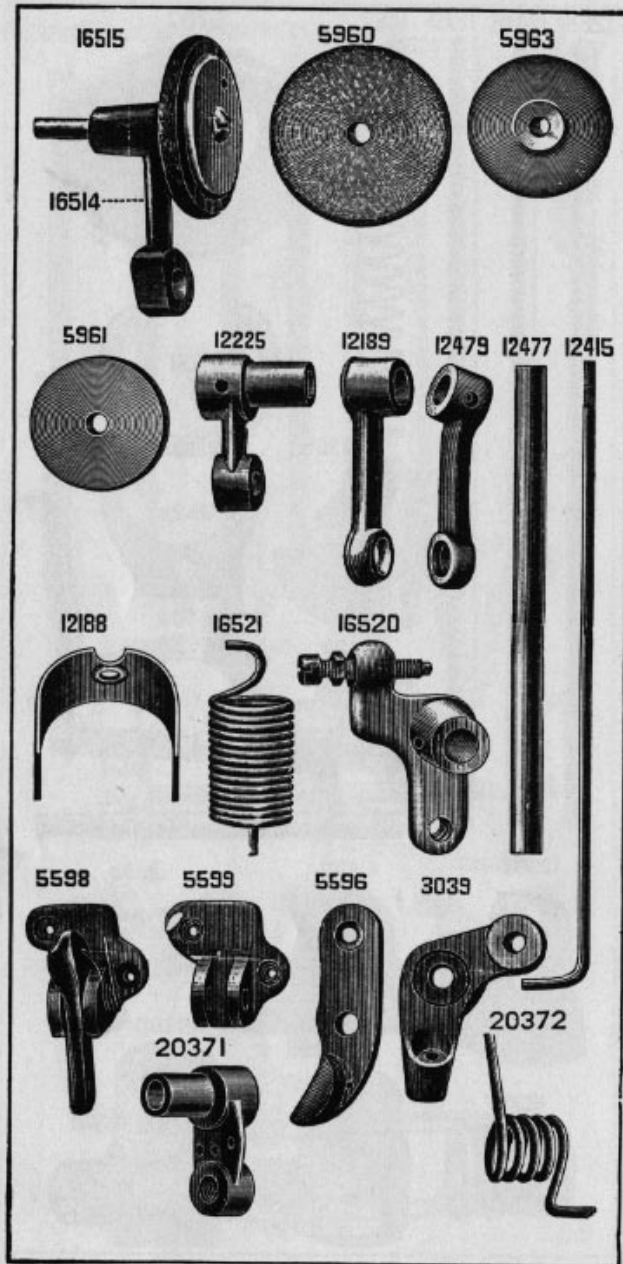


PLATE 770—FULL SIZE

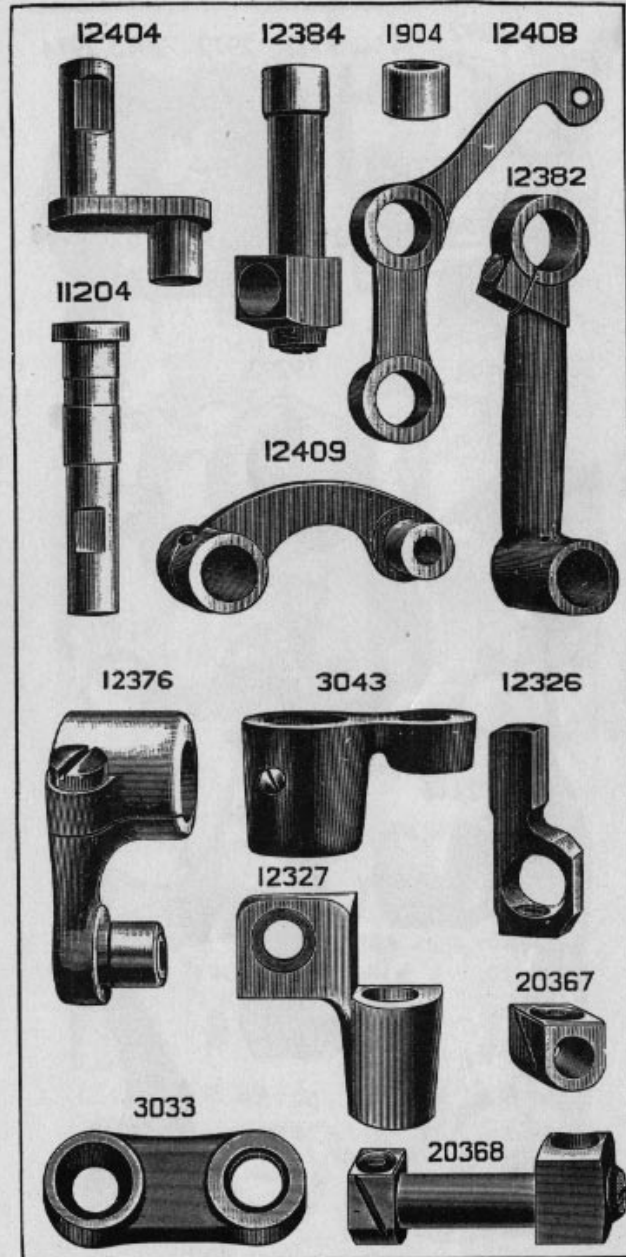
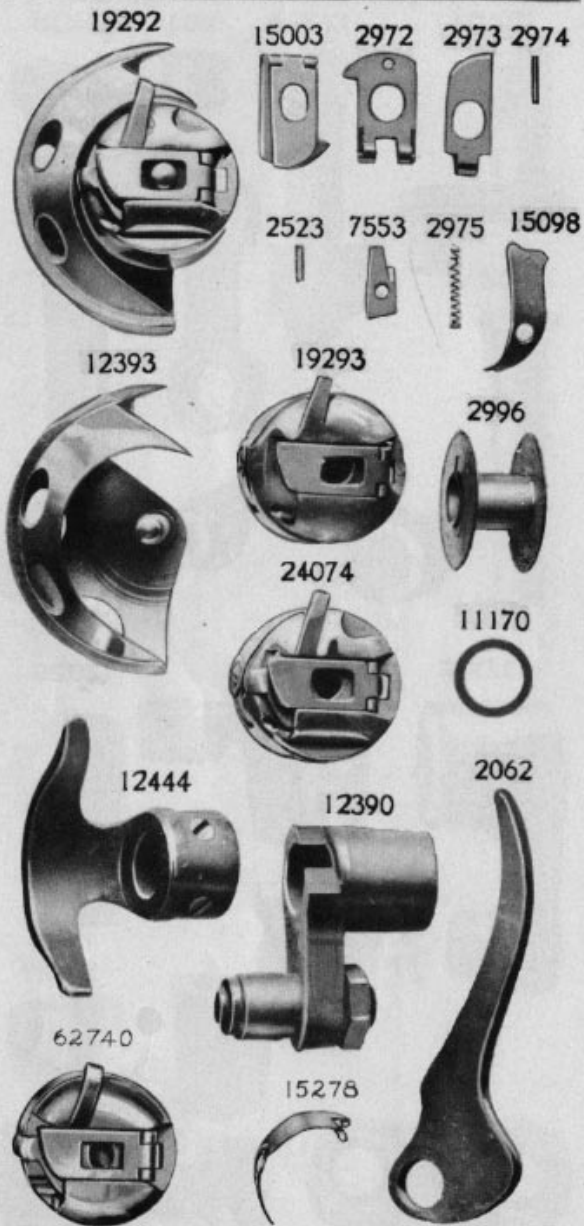




PLATE 771—FULL SIZE



- PLATE 772—FULL SIZE

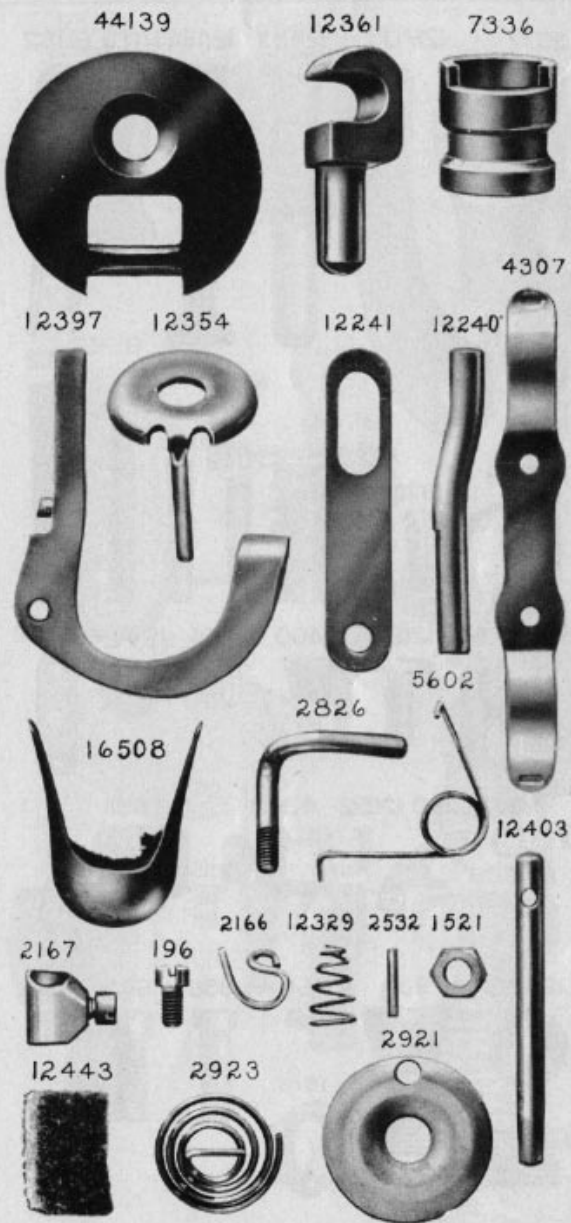


PLATE 773—FULL SIZE

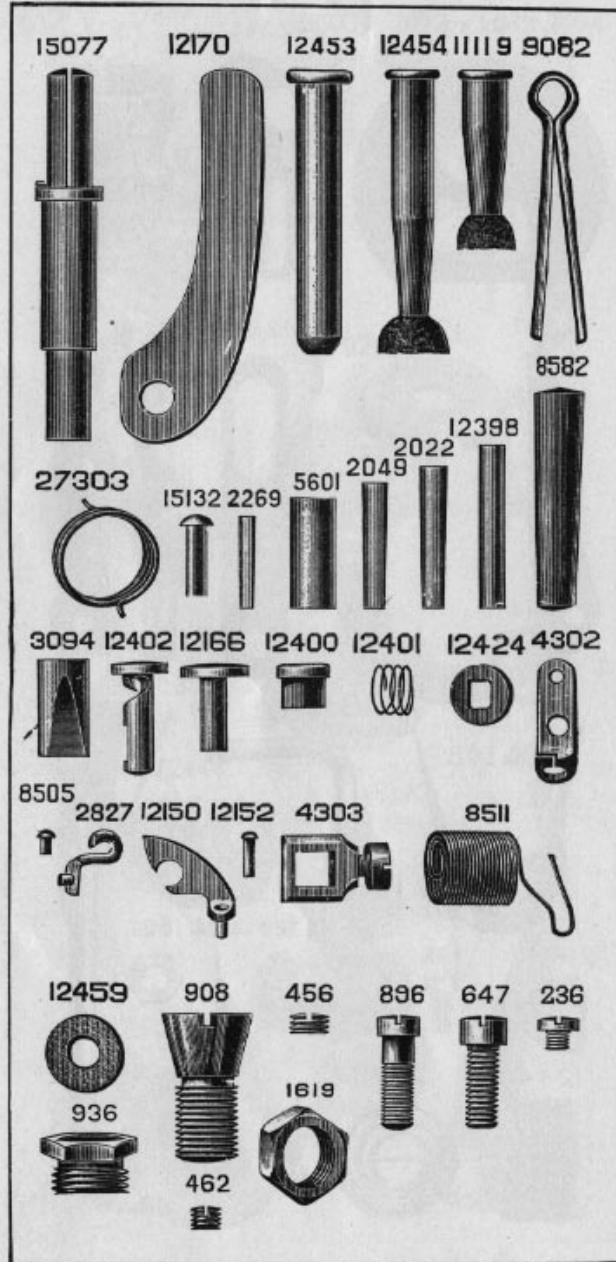


PLATE 774—FULL SIZE

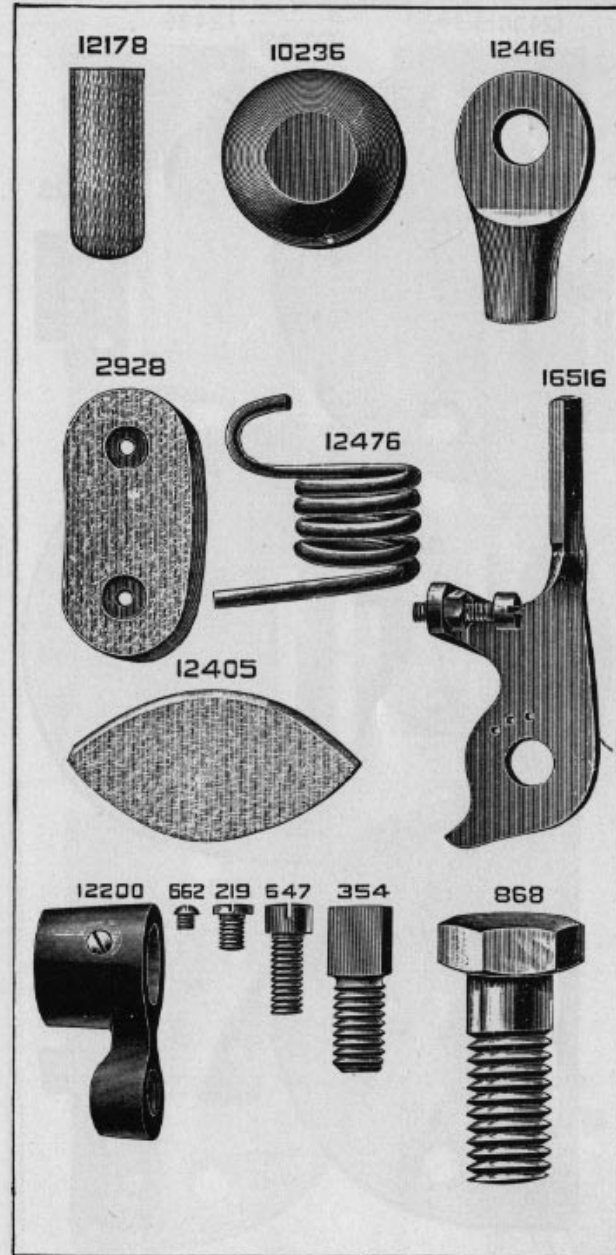


PLATE 776—FULL SIZE

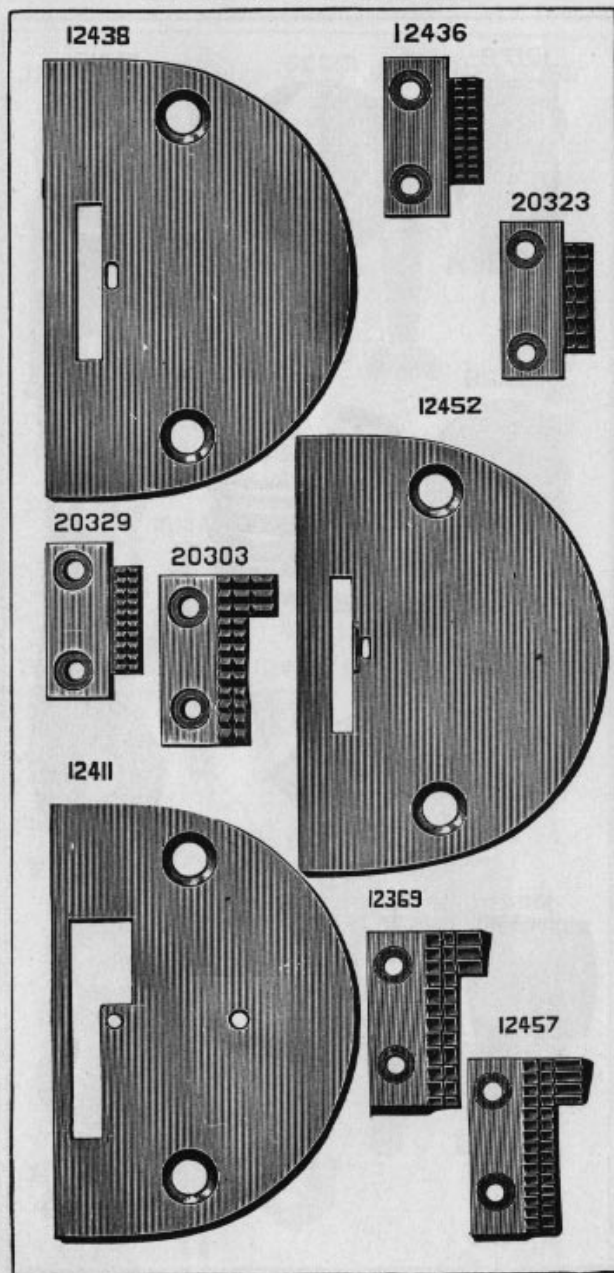


PLATE 777—FULL SIZE

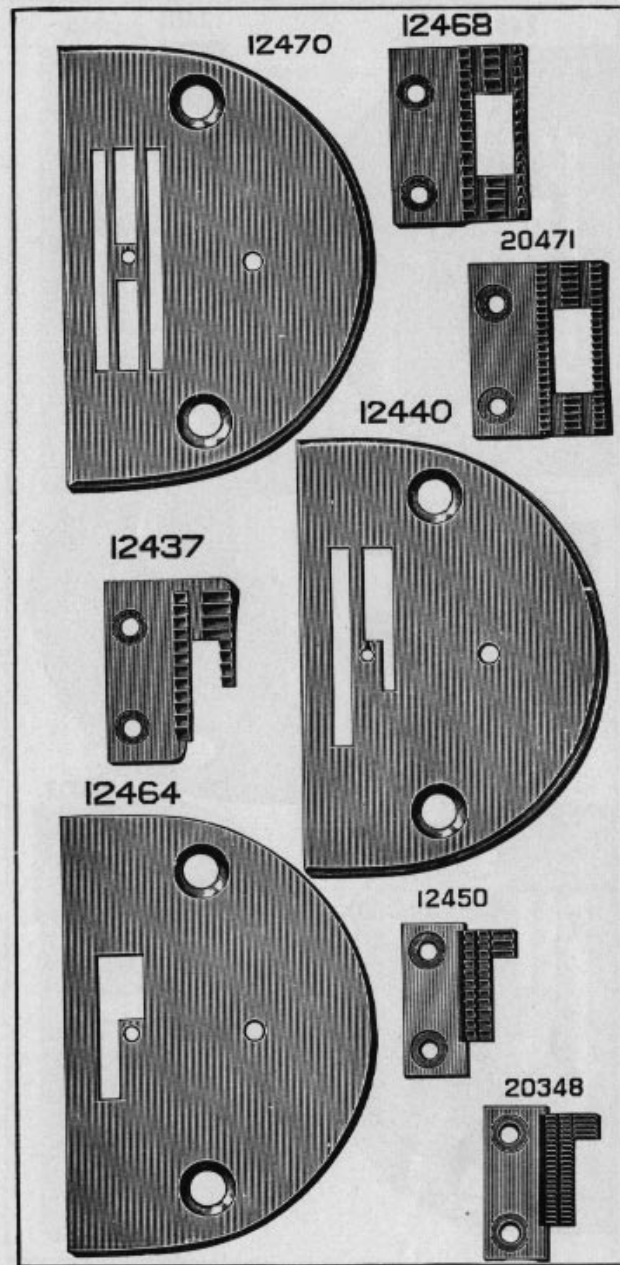


PLATE 778—FULL SIZE

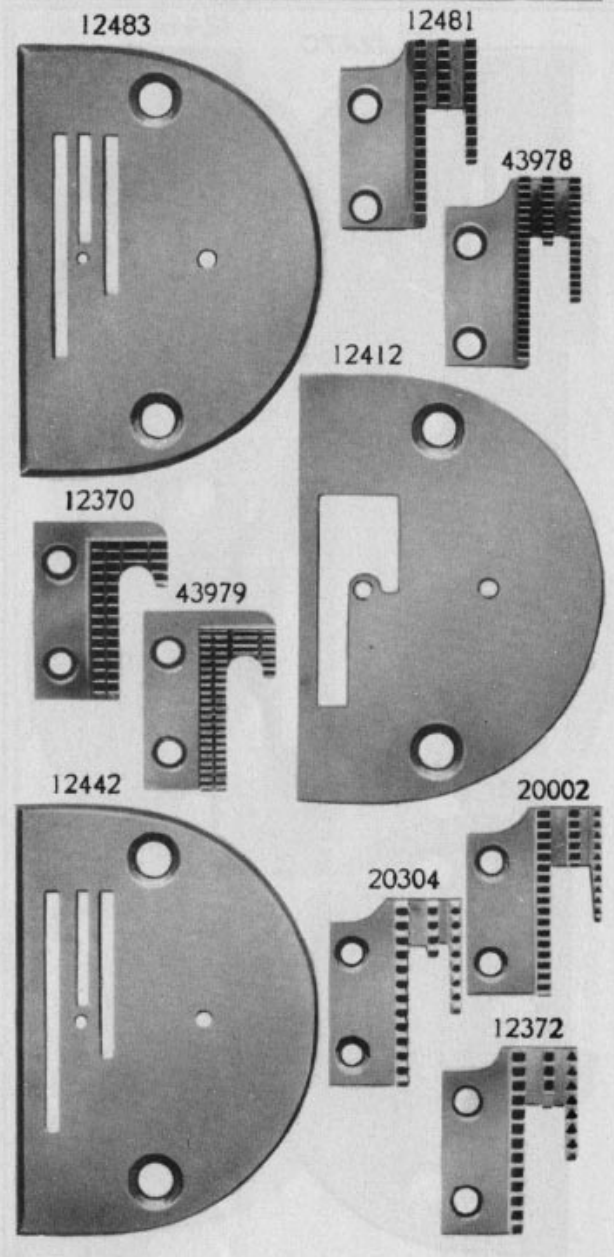


PLATE 779—FULL SIZE

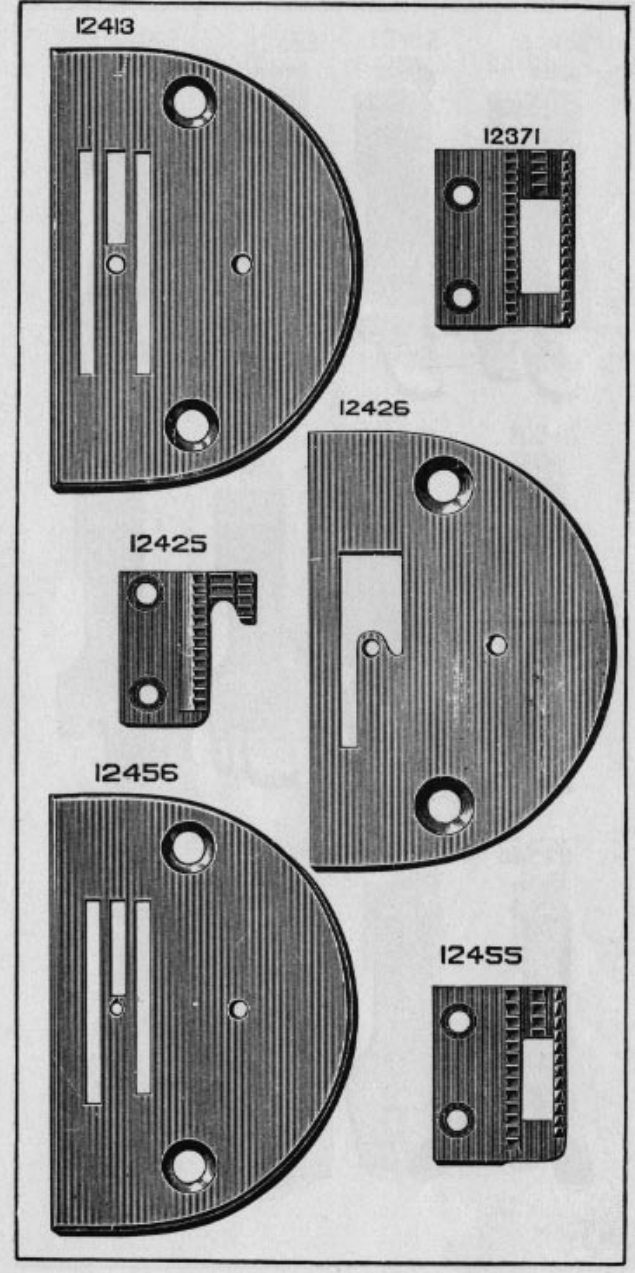




PLATE 780—FULL SIZE

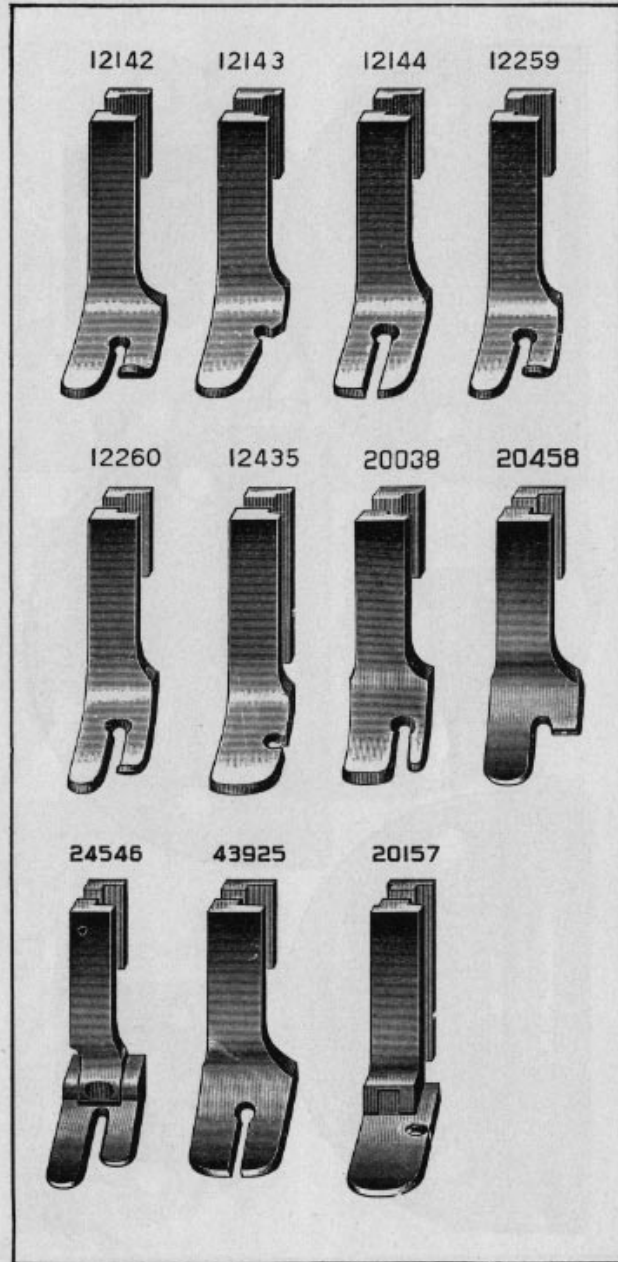


PLATE 781—FULL SIZE

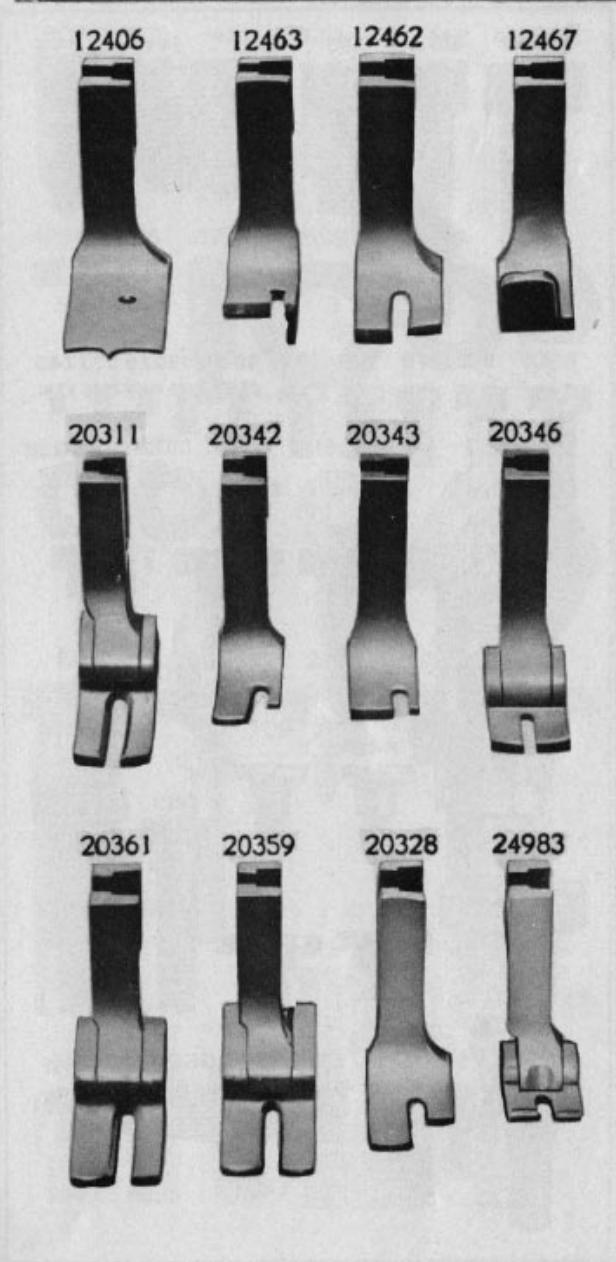


PLATE 782—FULL SIZE

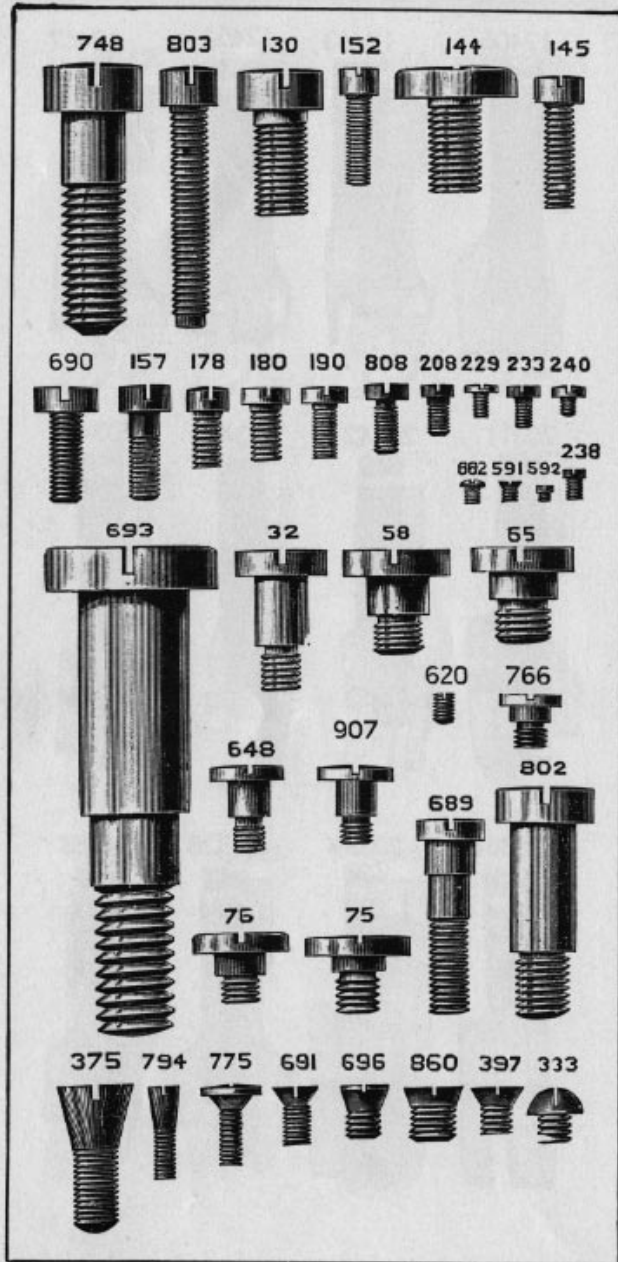


PLATE 783—FULL SIZE

807

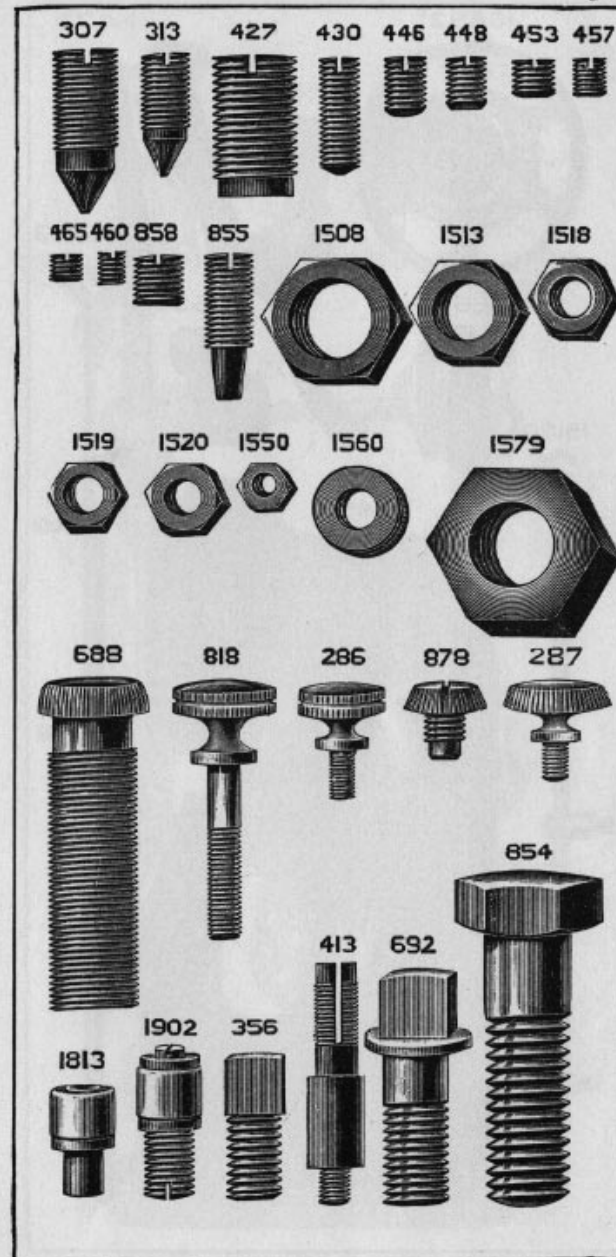


PLATE 818—ONE-FOURTH SIZE

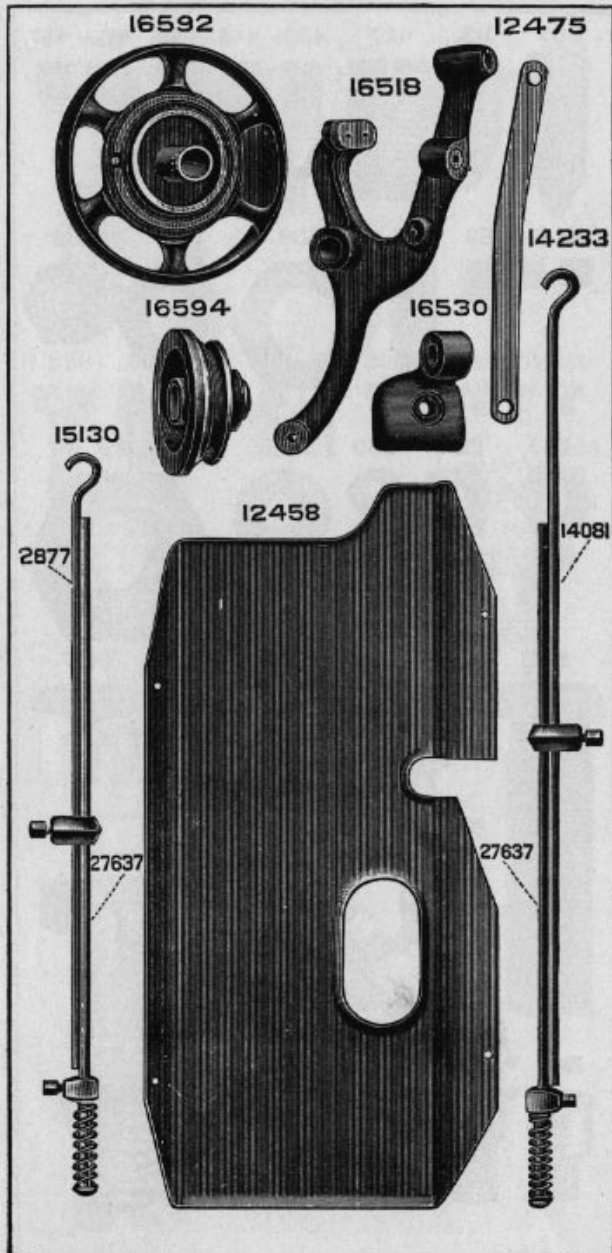
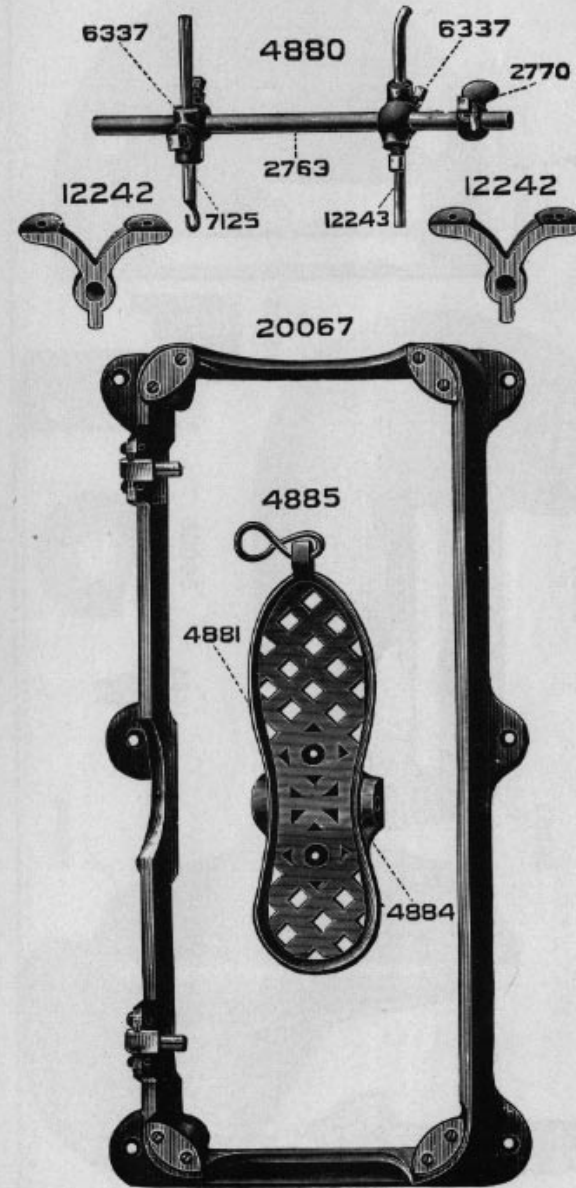


PLATE 819—ONE-FOURTH SIZE



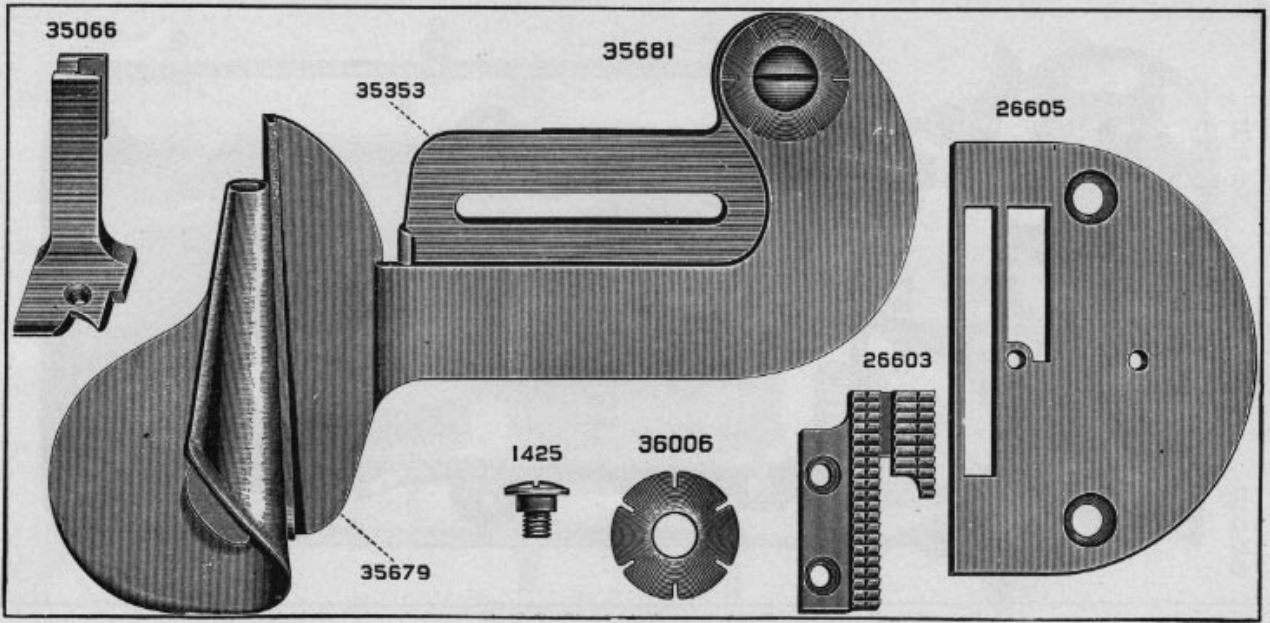


PLATE 932-FULL SIZE



PLATE 953—ONE-HALF SIZE

26755

35345

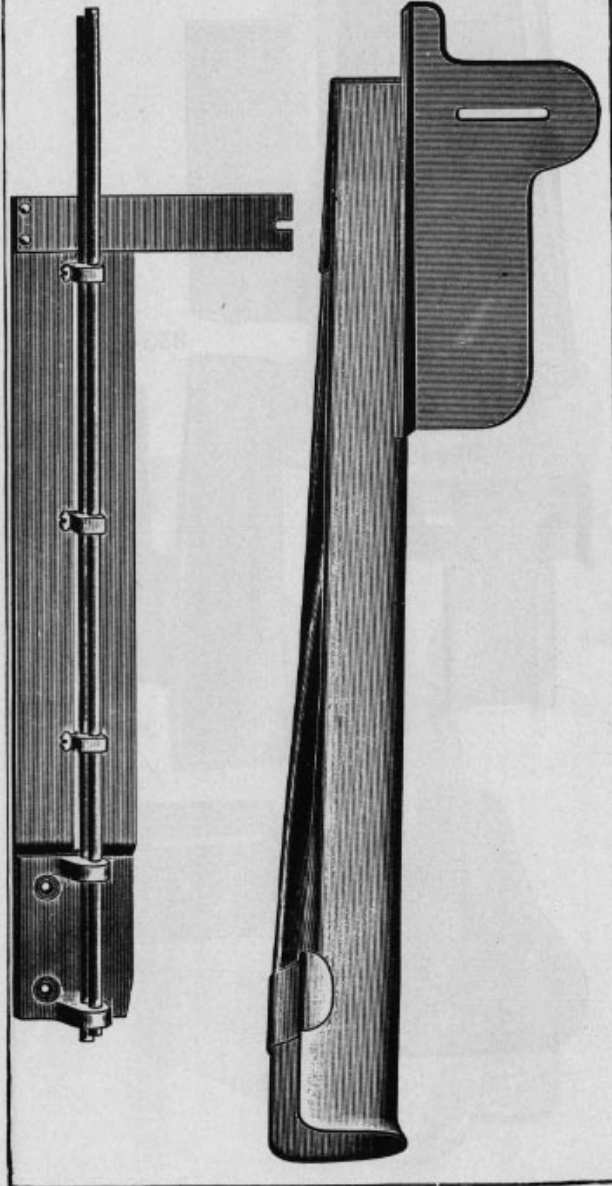
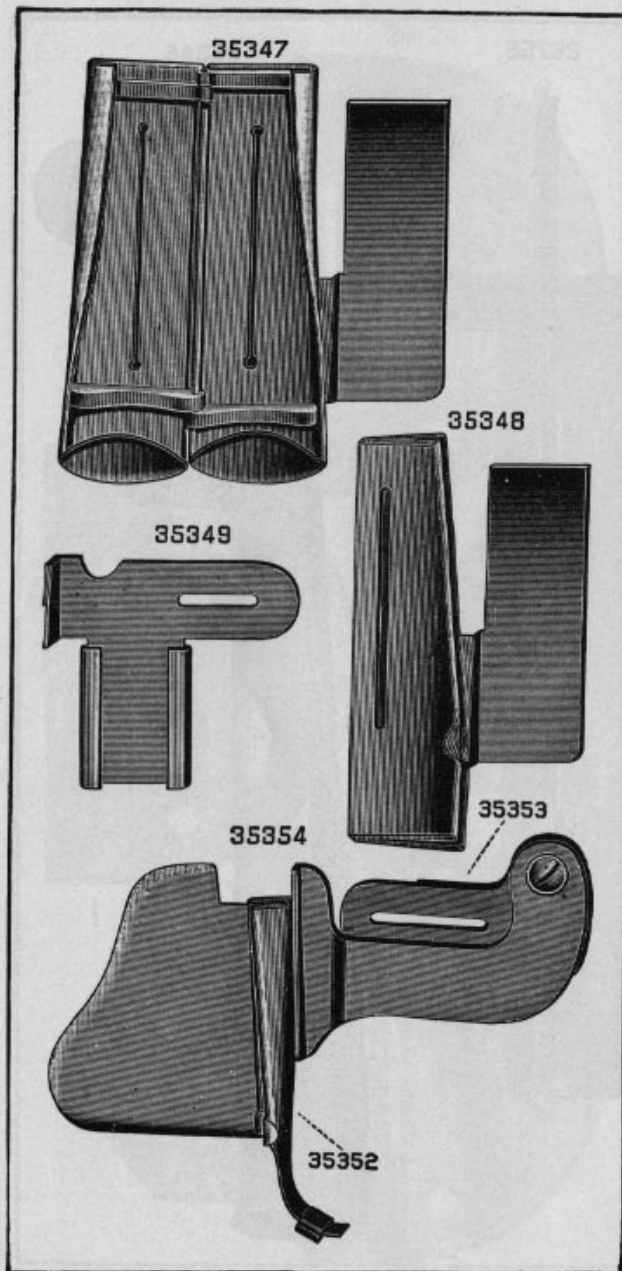
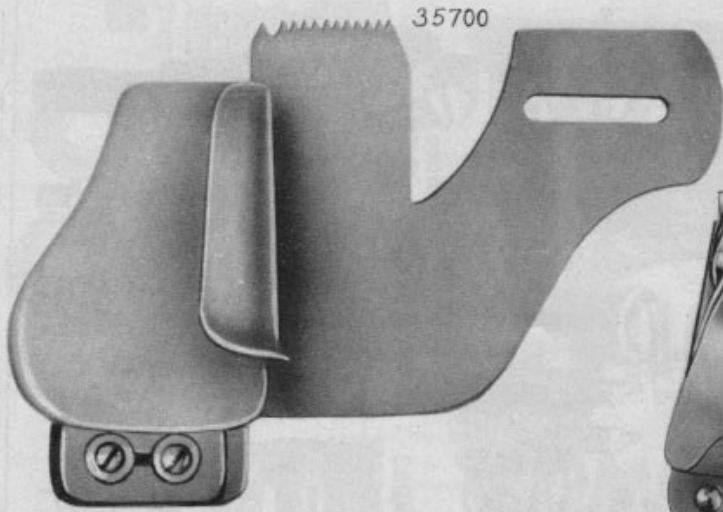
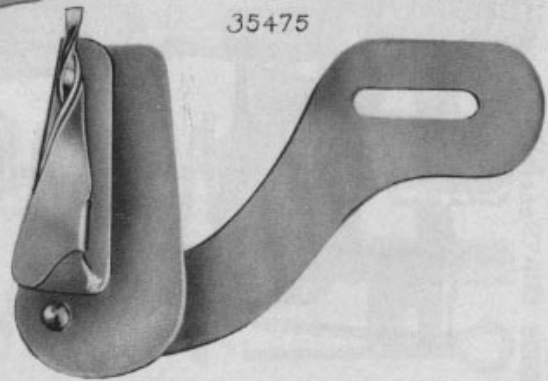


PLATE 970—ONE-HALF SIZE





35700



35475

PLATE 976—FULL SIZE

PLATE 984—FULL SIZE

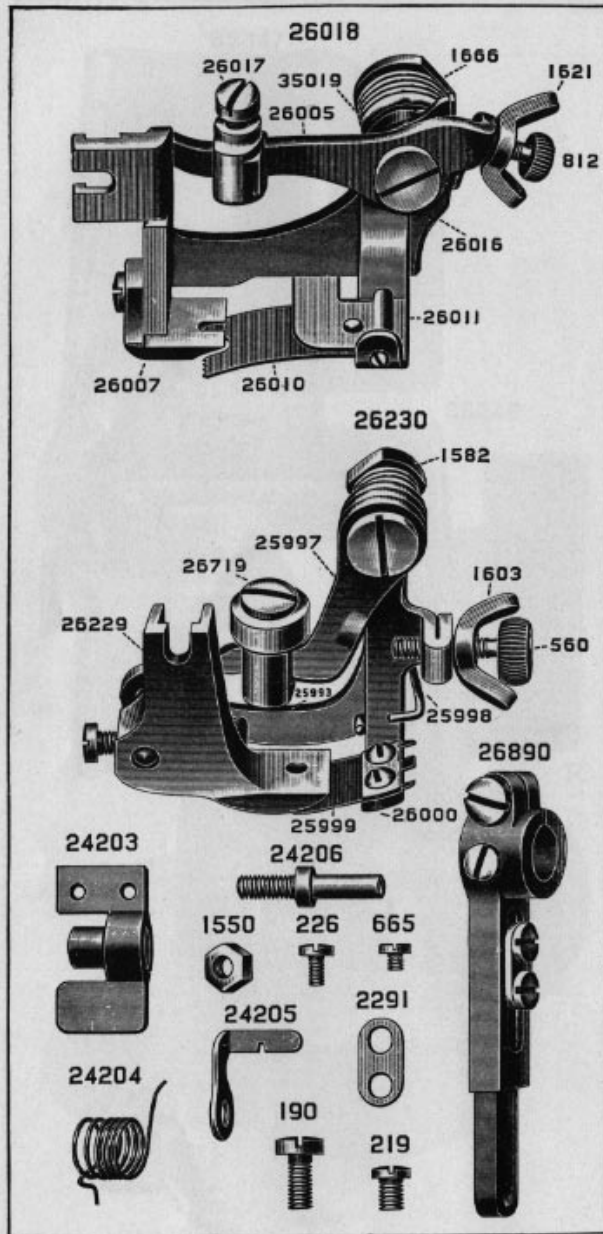


PLATE 1101—FULL SIZE

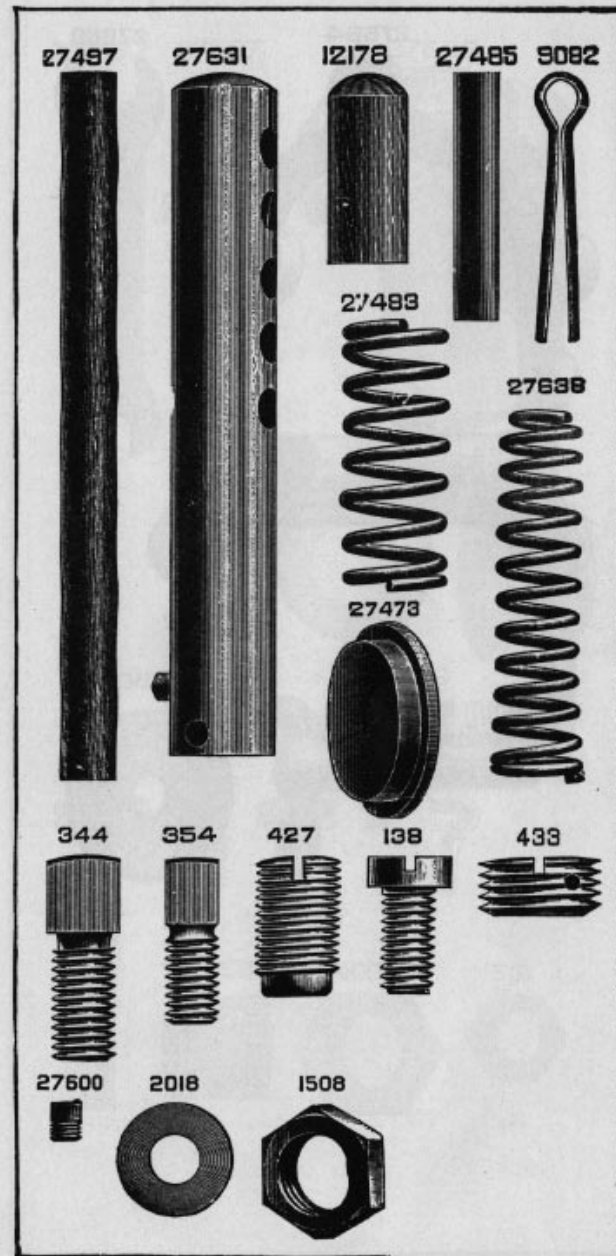


PLATE 1104—ONE-HALF SIZE

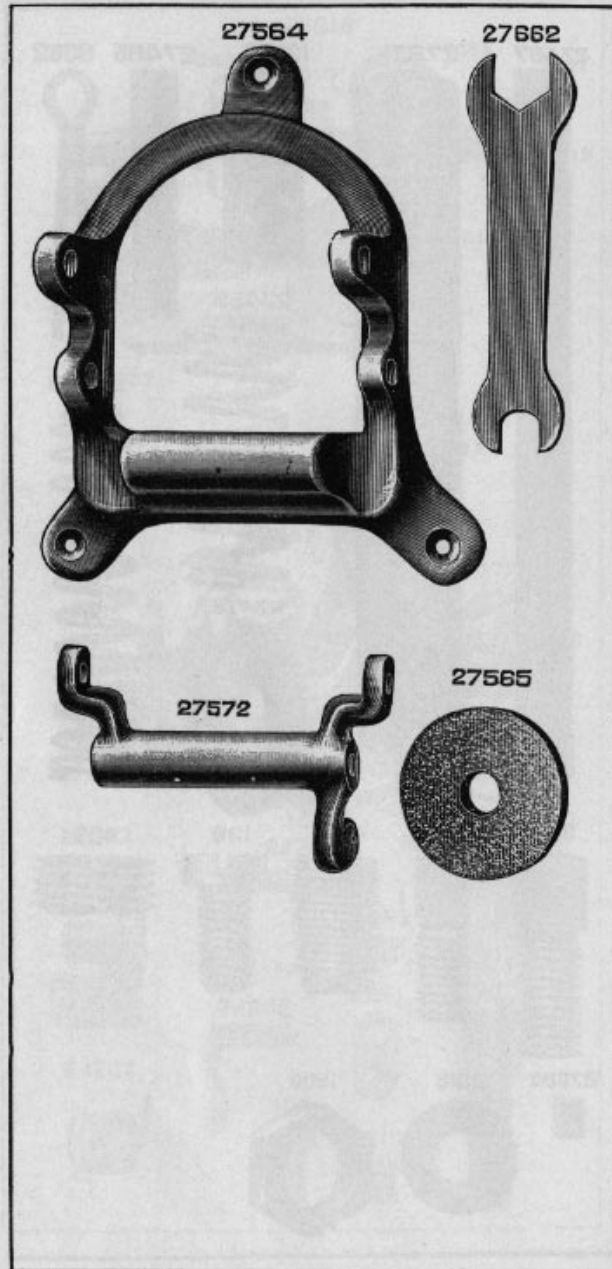


PLATE 1105—FULL SIZE

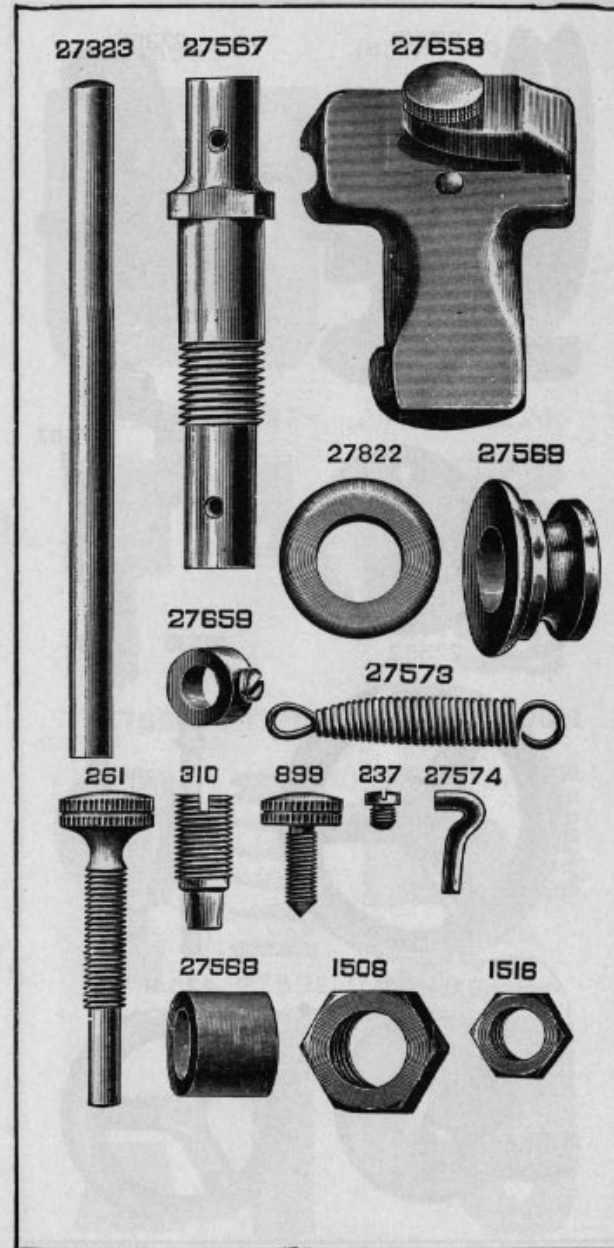




PLATE 1162—ONE-HALF SIZE

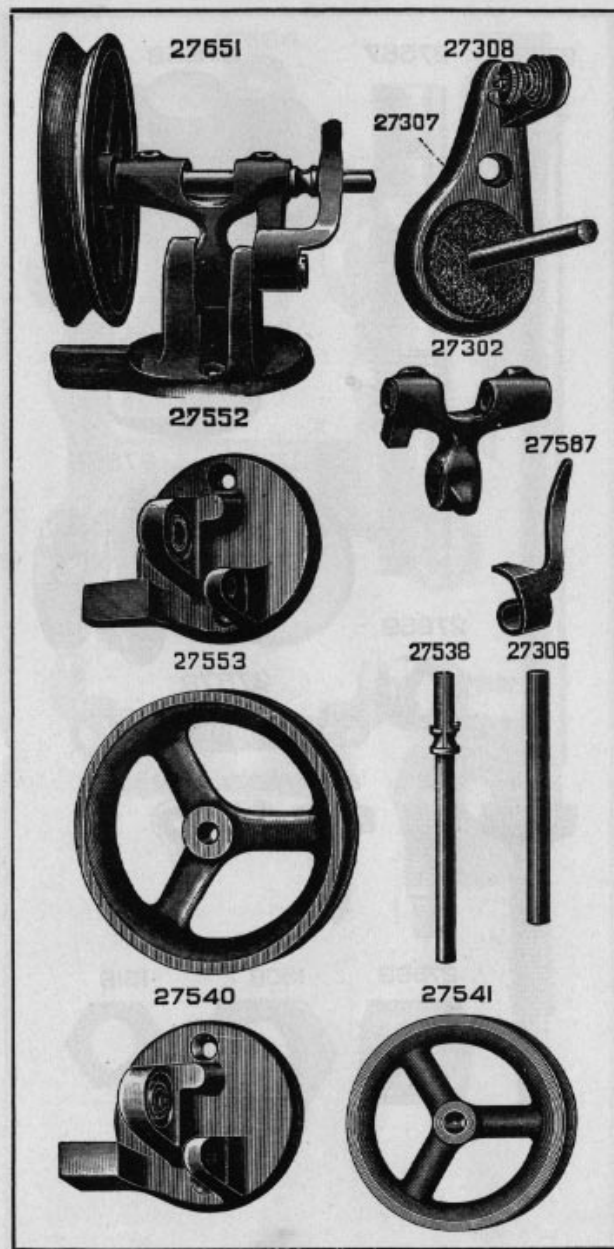


PLATE 1206—FULL SIZE

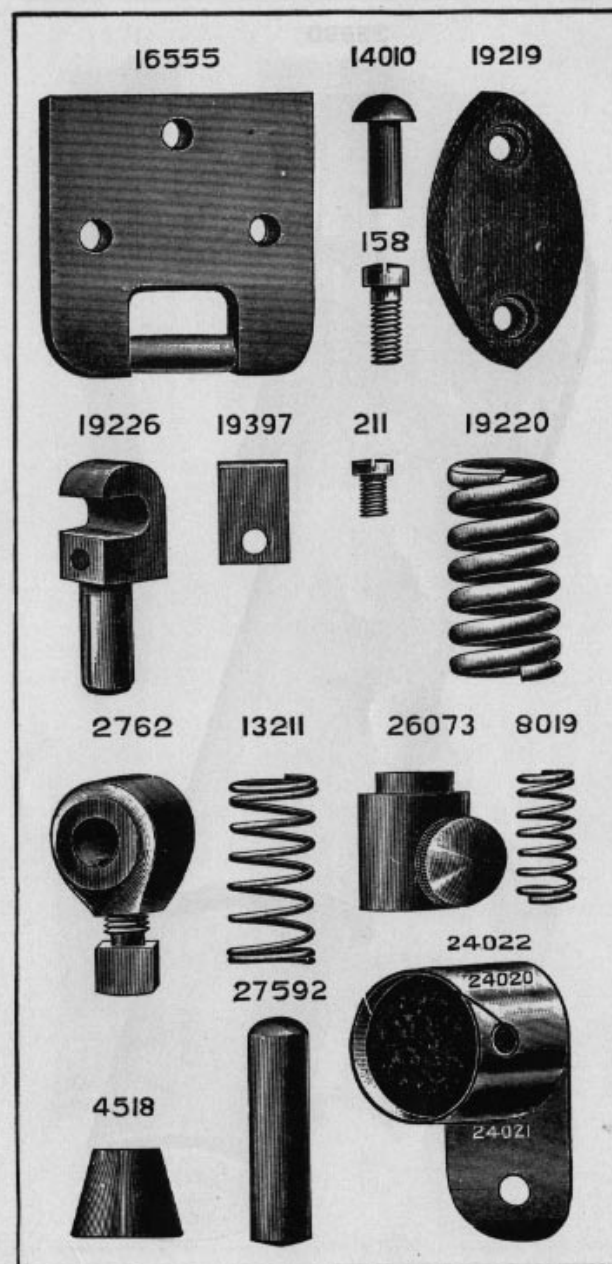


PLATE 1246—FULL SIZE

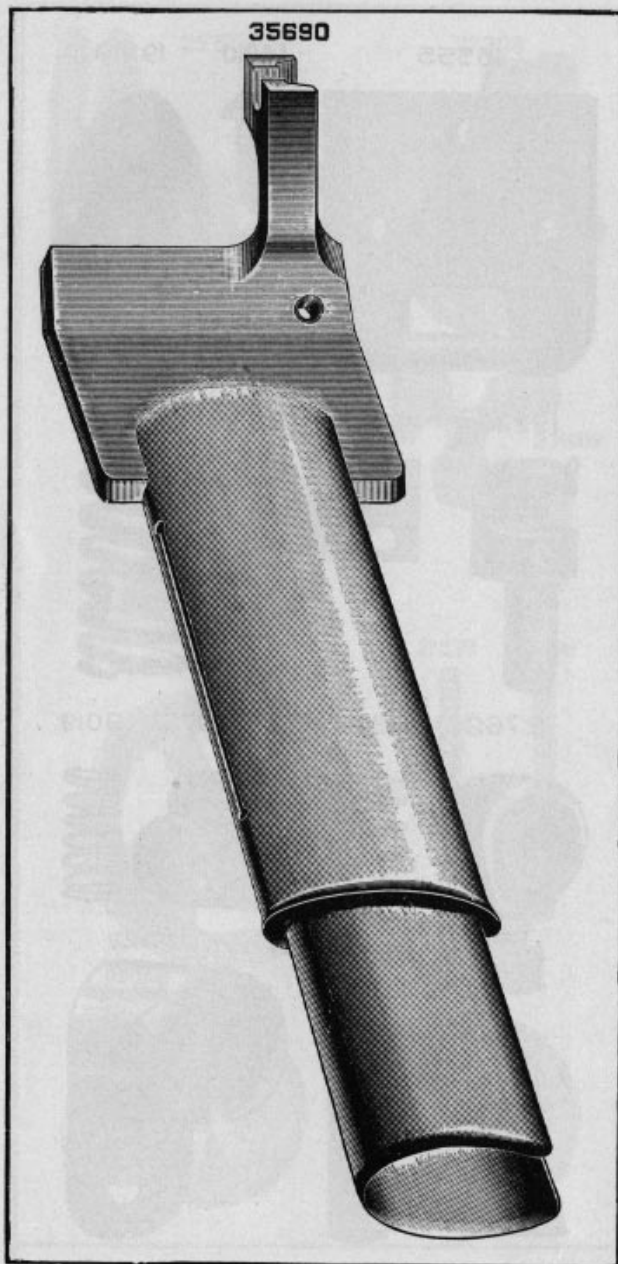


PLATE 1252—FULL SIZE

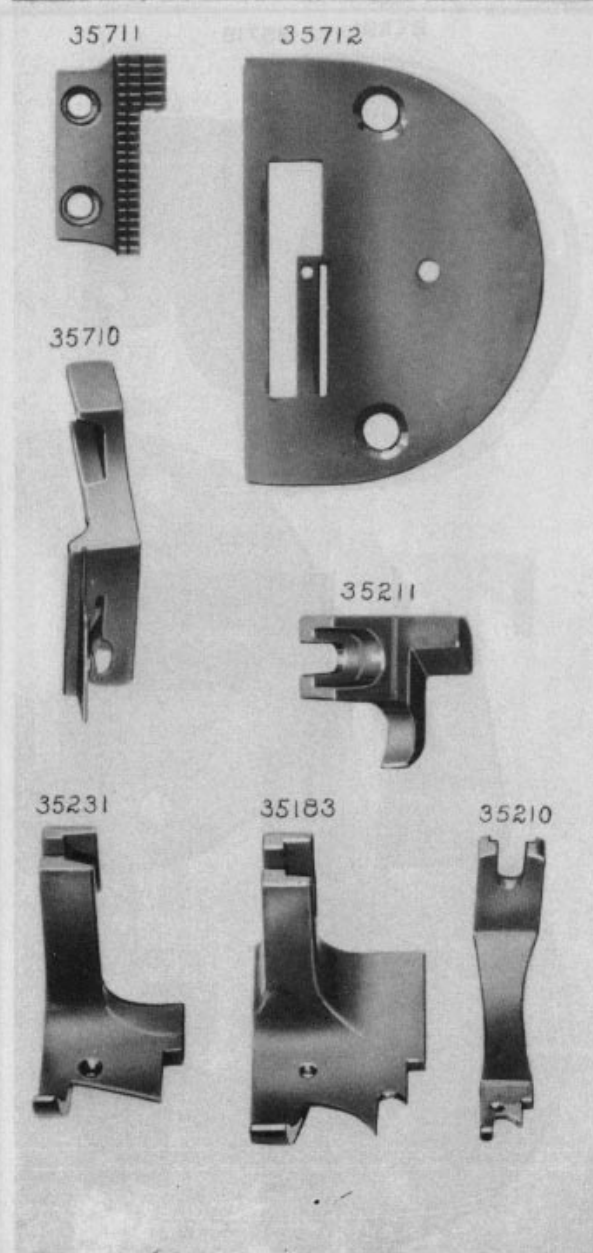


PLATE 1253—ONE-HALF SIZE

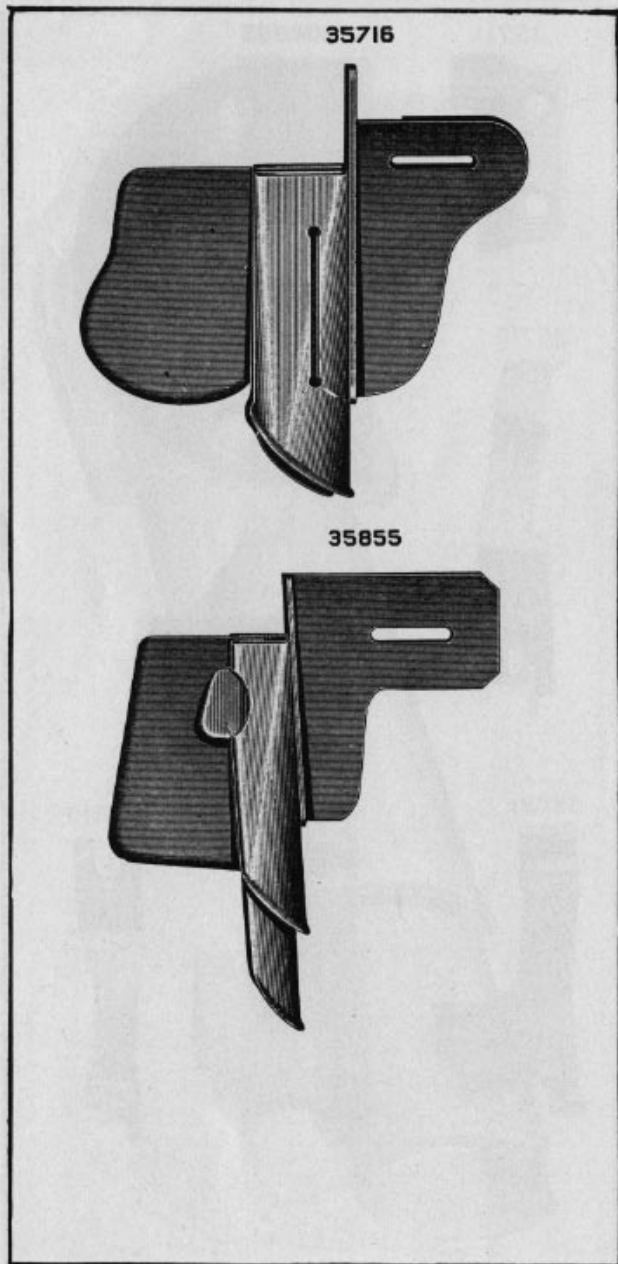


PLATE 1258—FULL SIZE

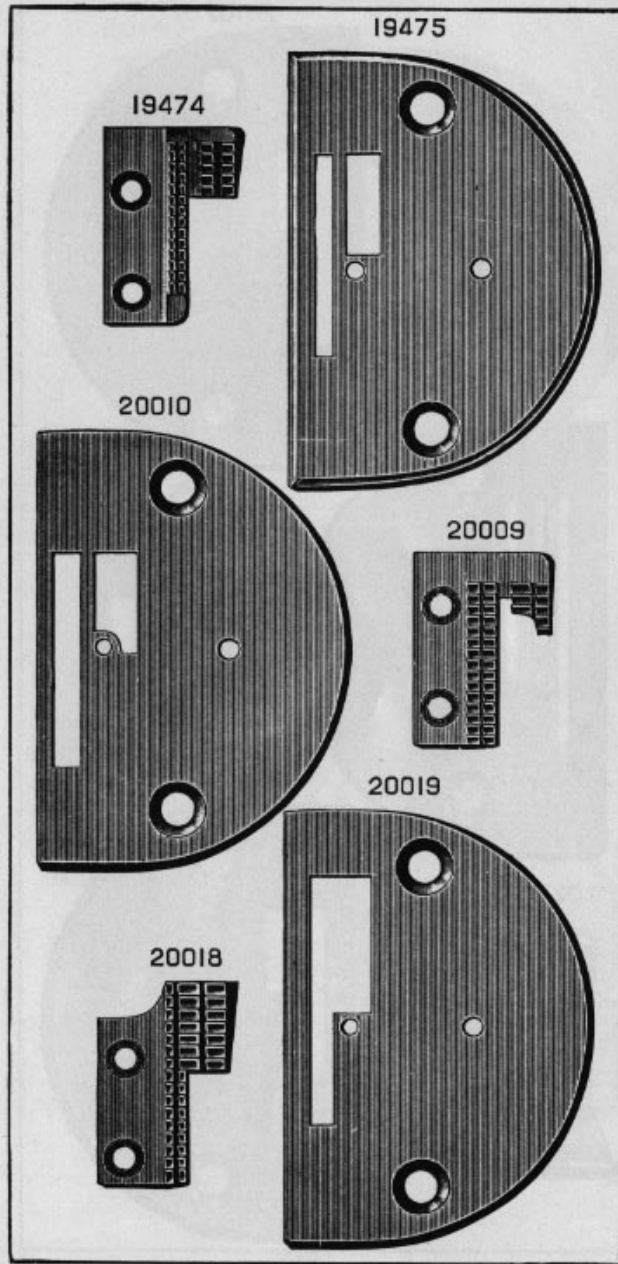




PLATE 1259—FULL SIZE

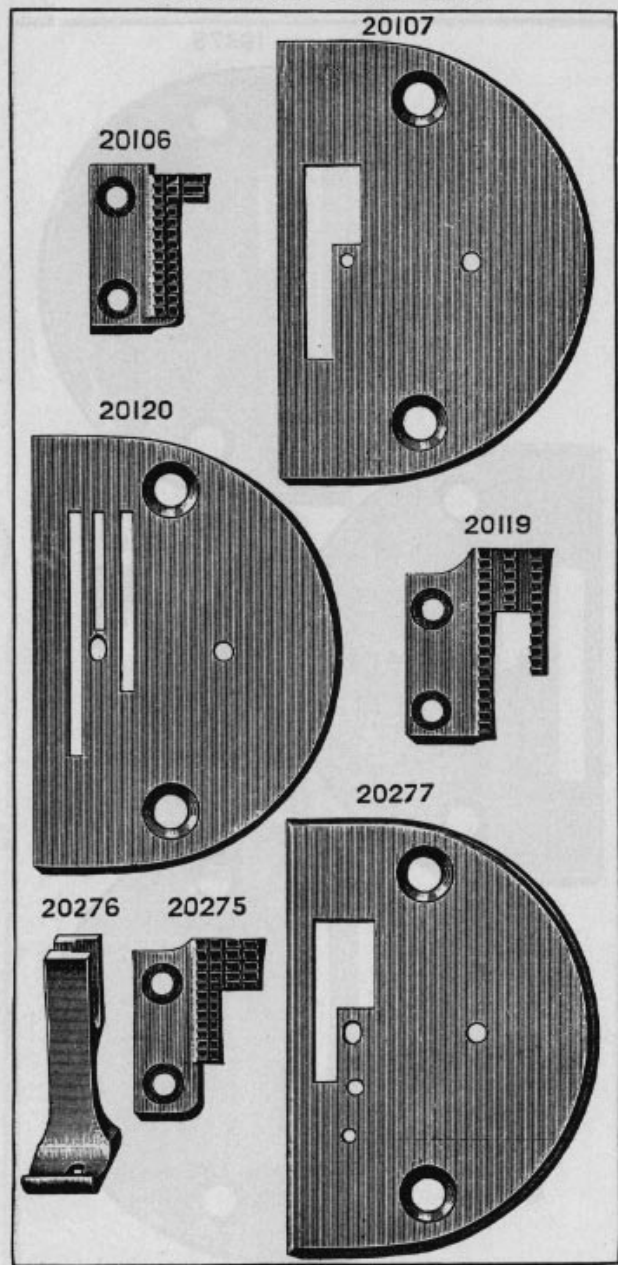


PLATE 1260—FULL SIZE

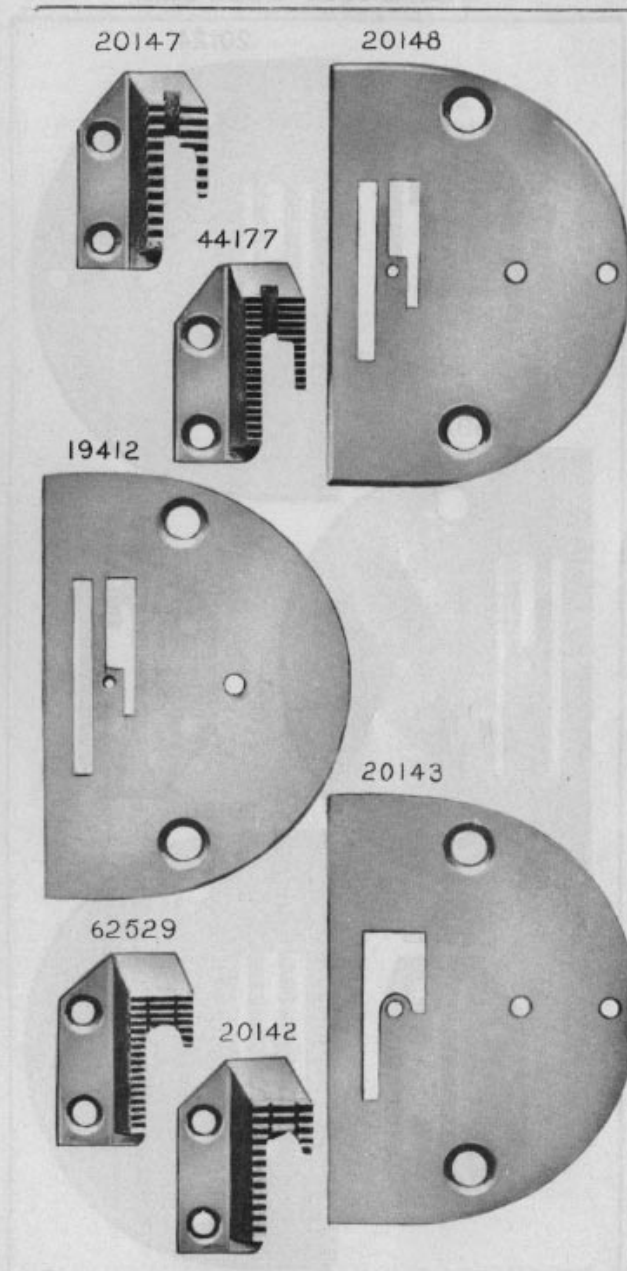


PLATE 1261—FULL SIZE

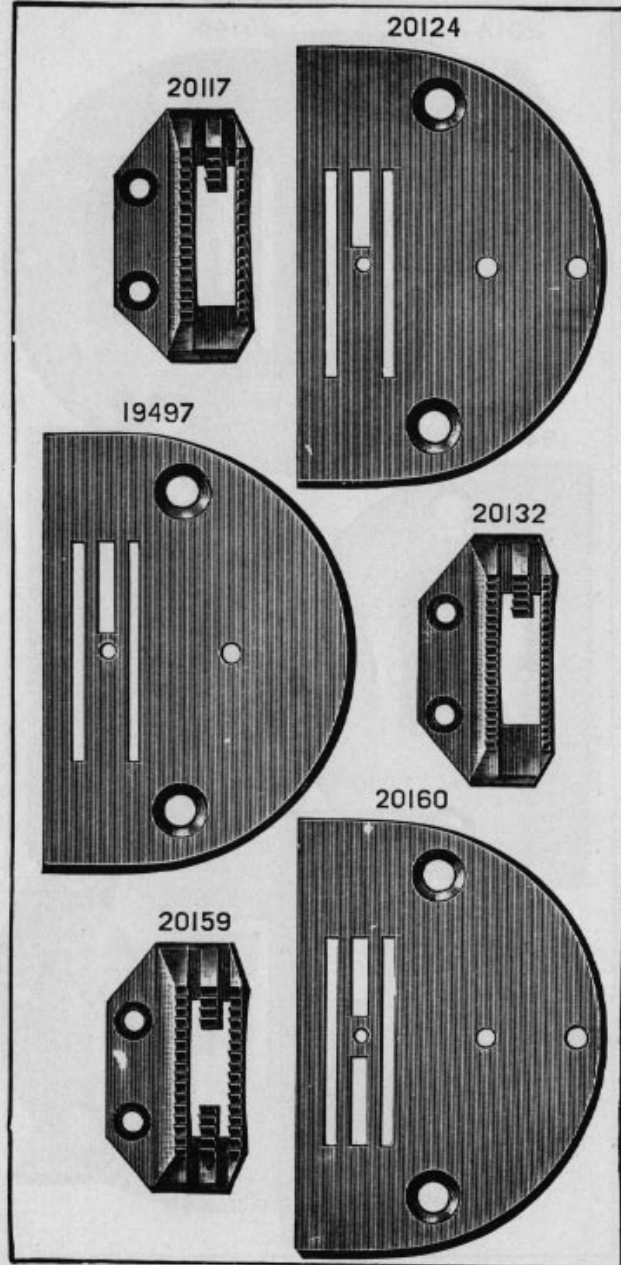


PLATE 1262—FULL SIZE

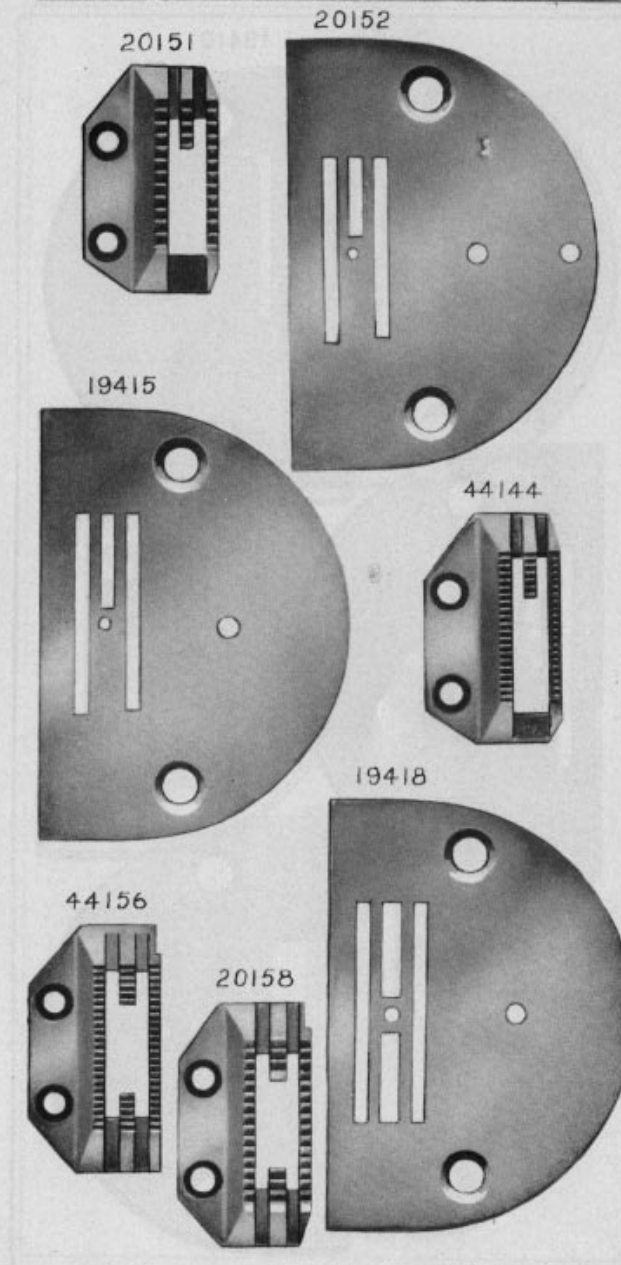


PLATE 1263—FULL SIZE

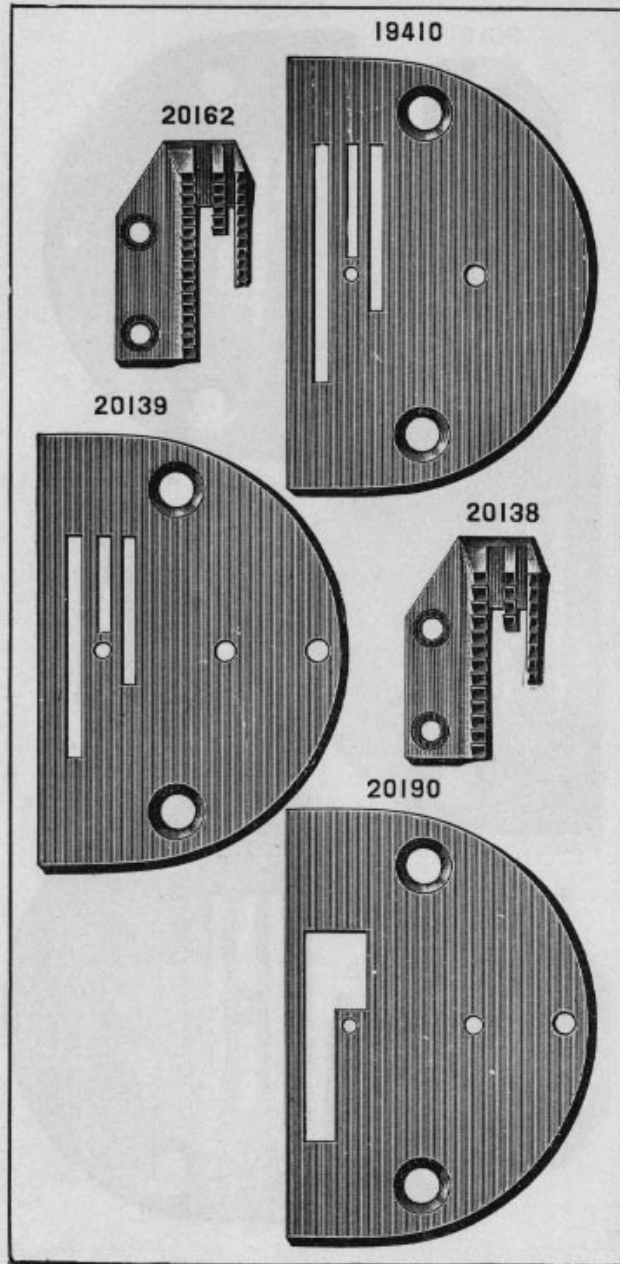


PLATE 1267—FULL SIZE

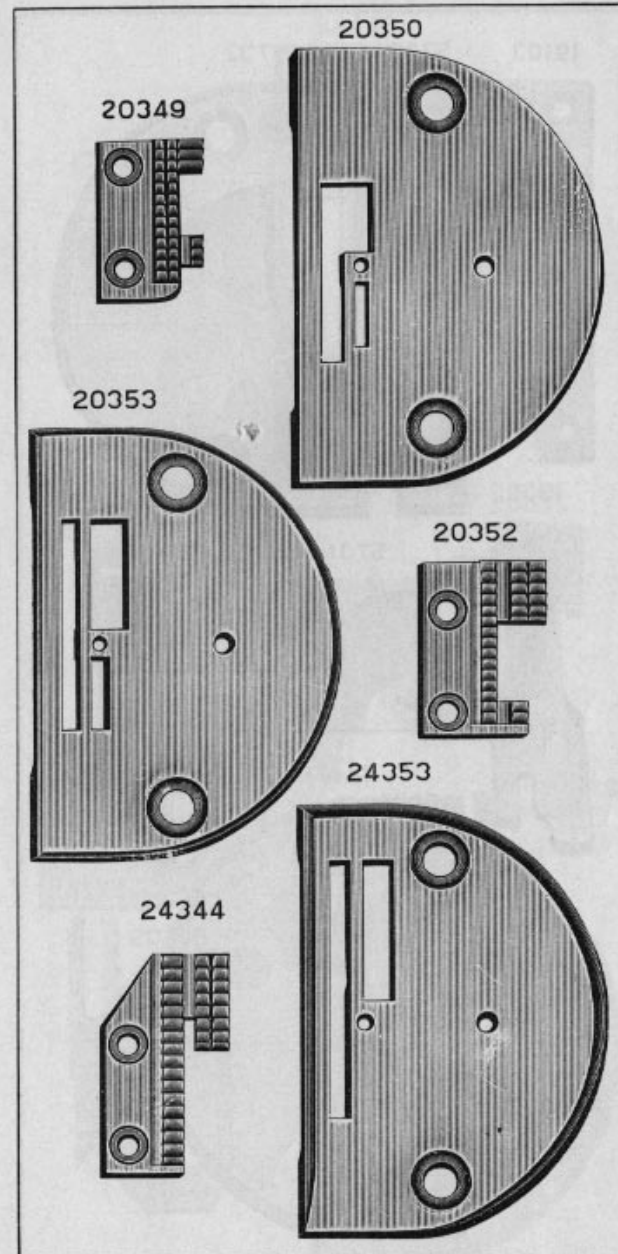


PLATE 1271—FULL SIZE

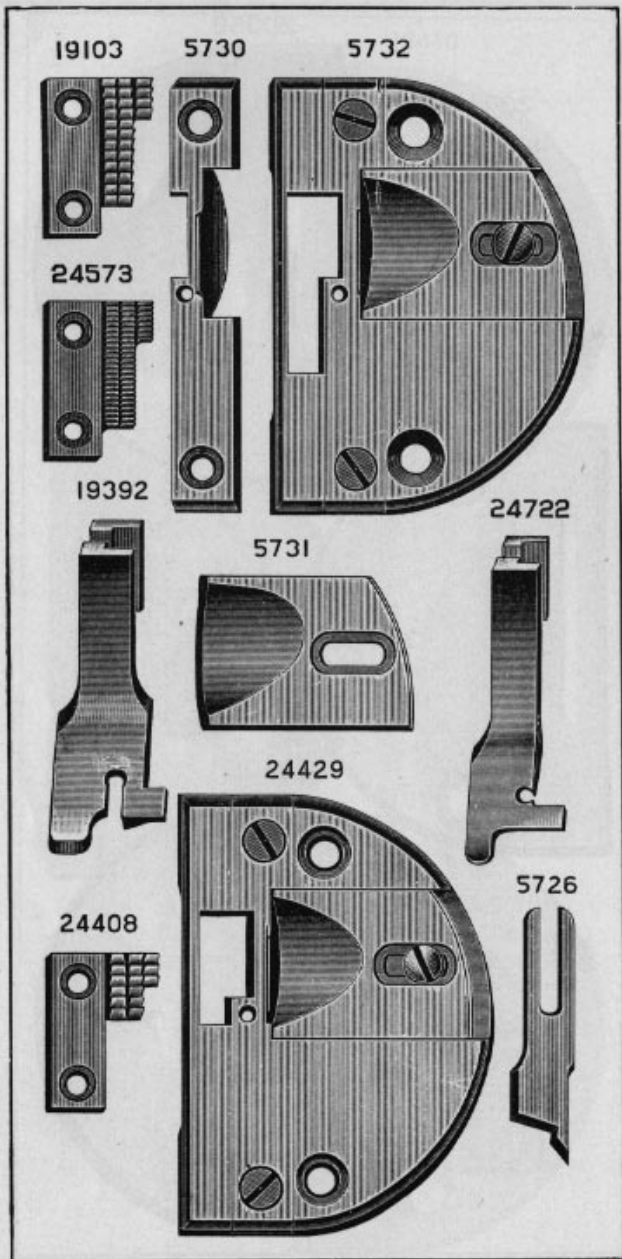


PLATE 1274—FULL SIZE

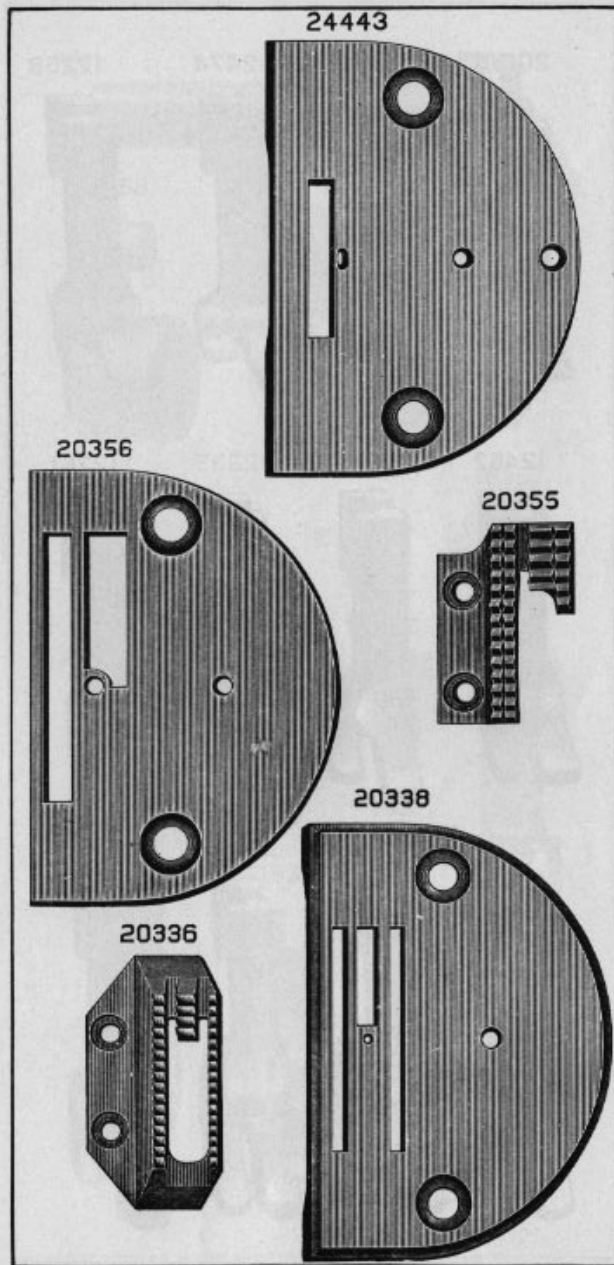




PLATE 1308—FULL SIZE

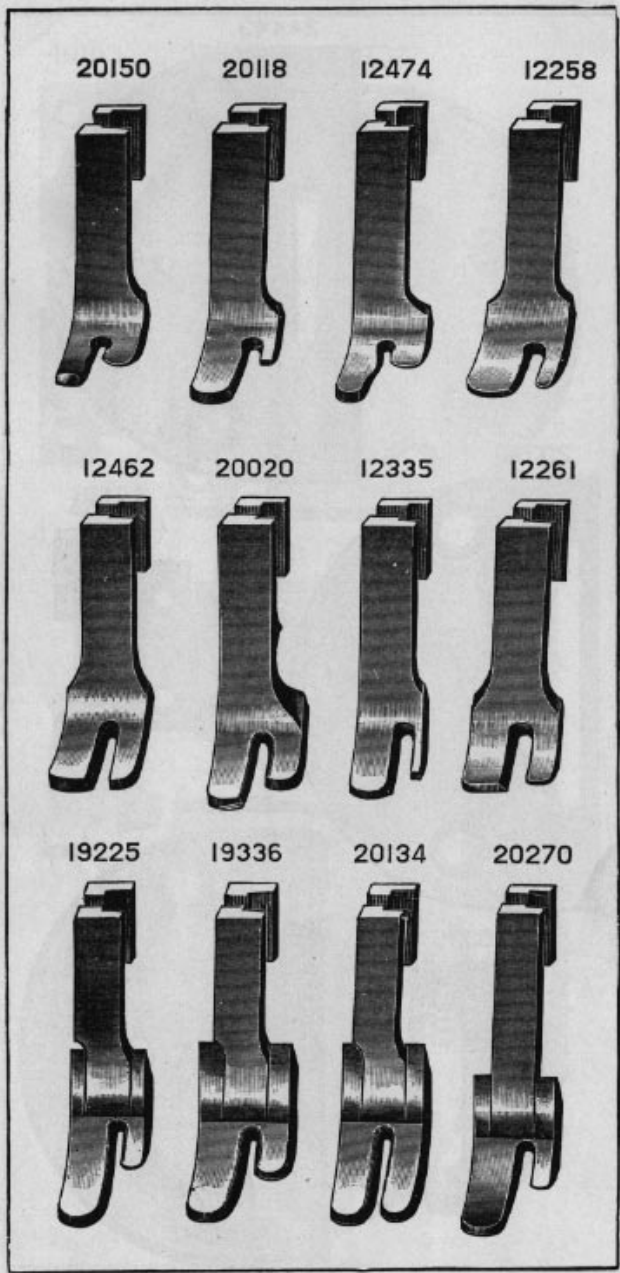


PLATE 1312—FULL SIZE

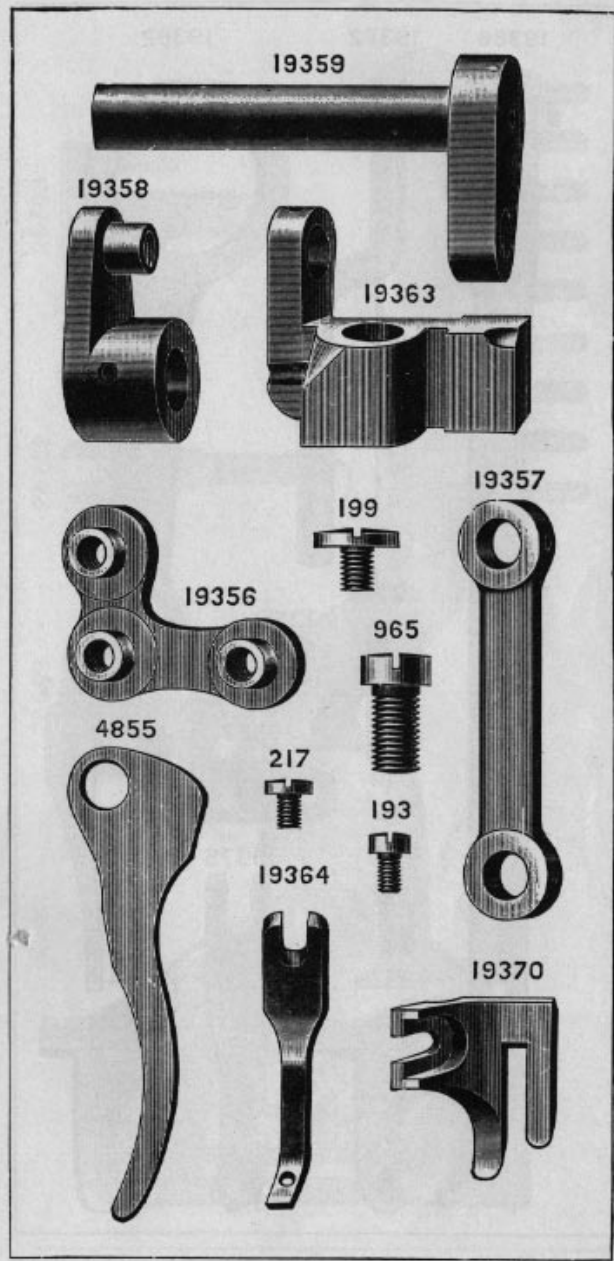
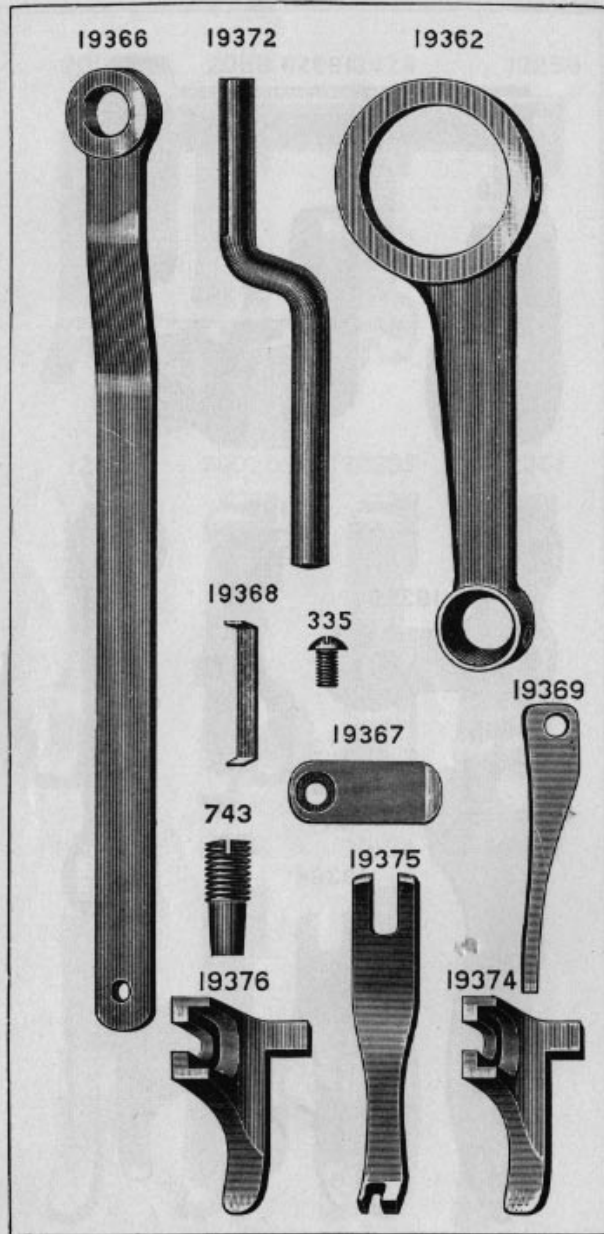


PLATE 1313—FULL SIZE



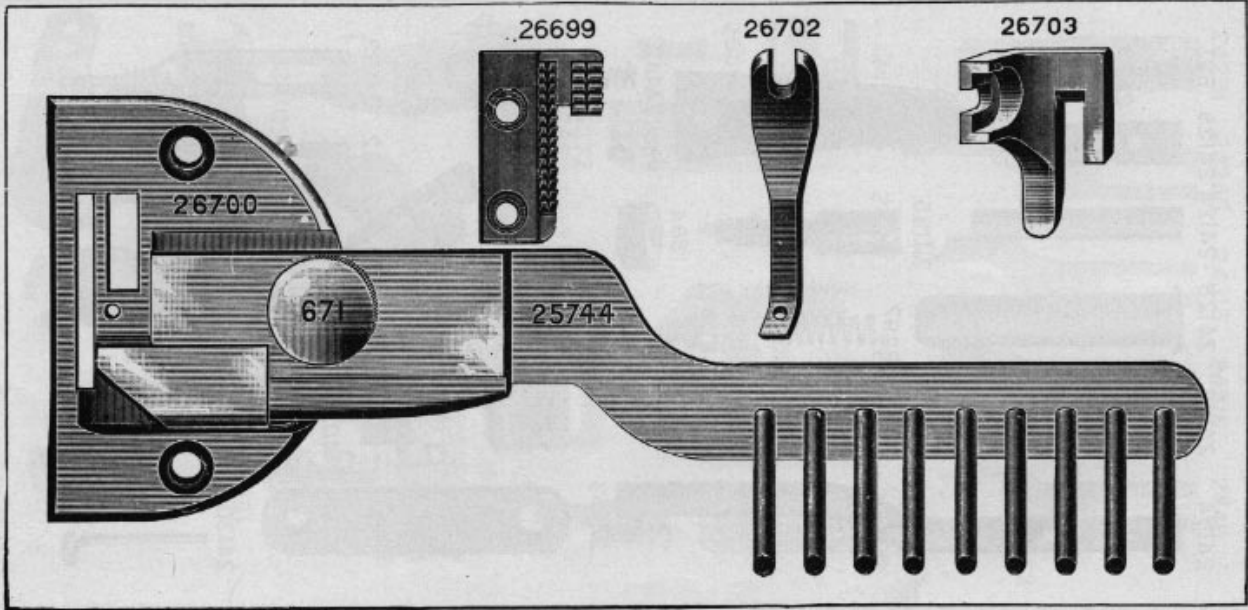


PLATE 1314—FULL SIZE

PLATE 1317—FULL SIZE

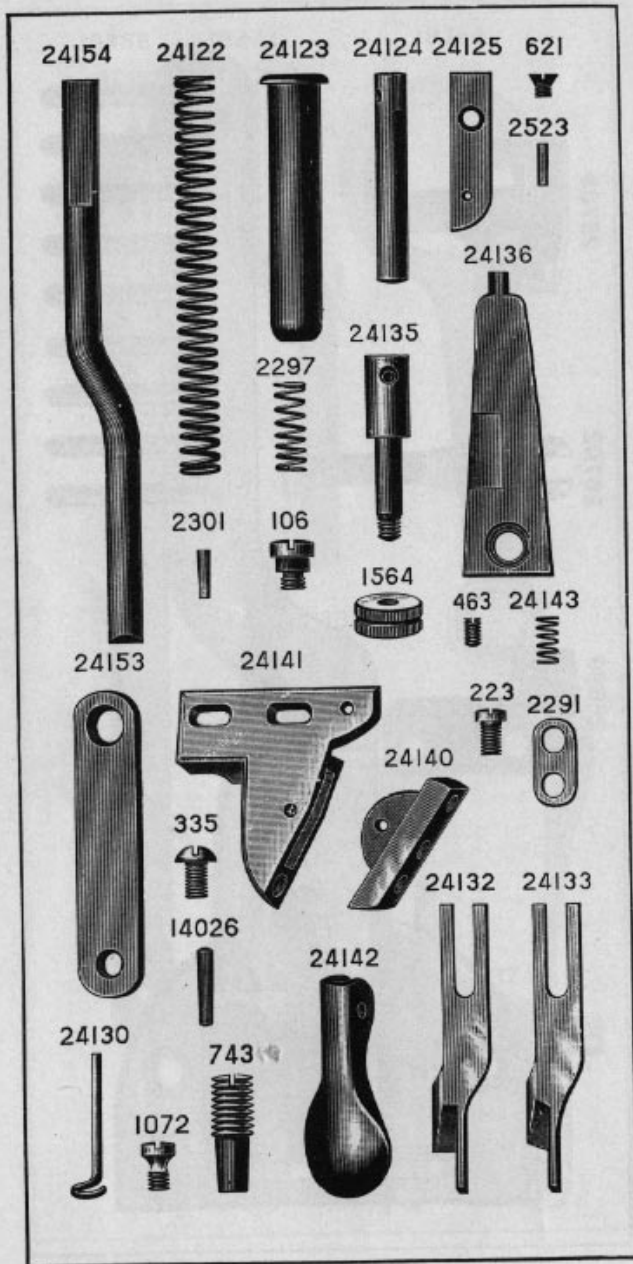


PLATE 1321—FULL SIZE

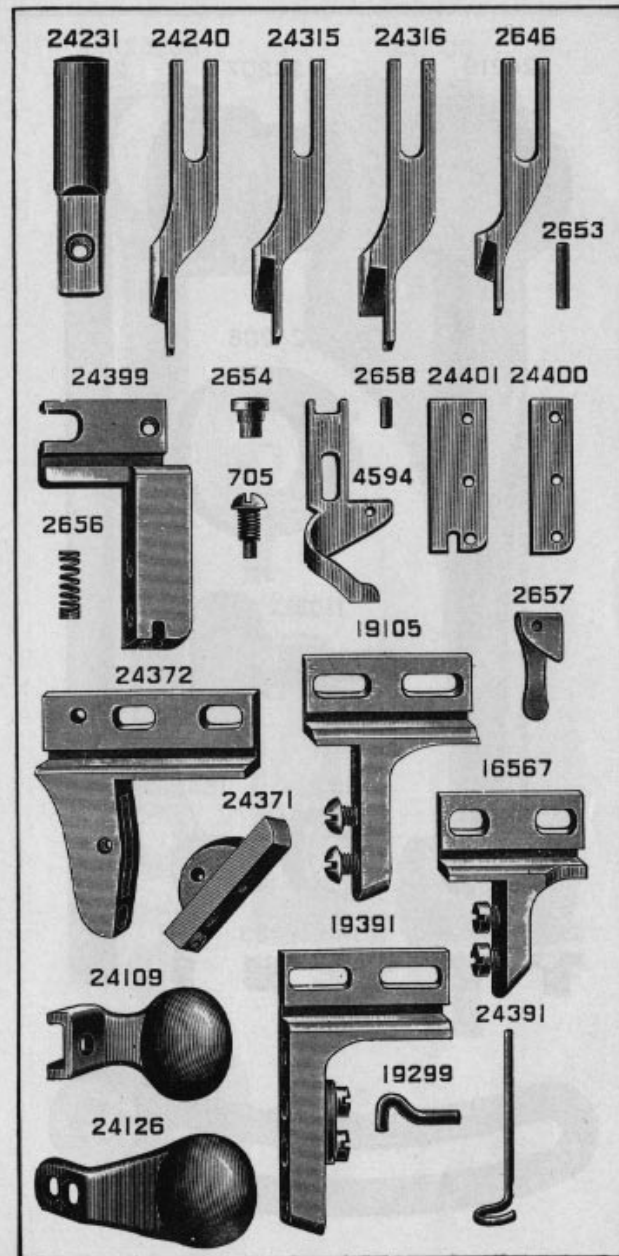




PLATE 1323—FULL SIZE

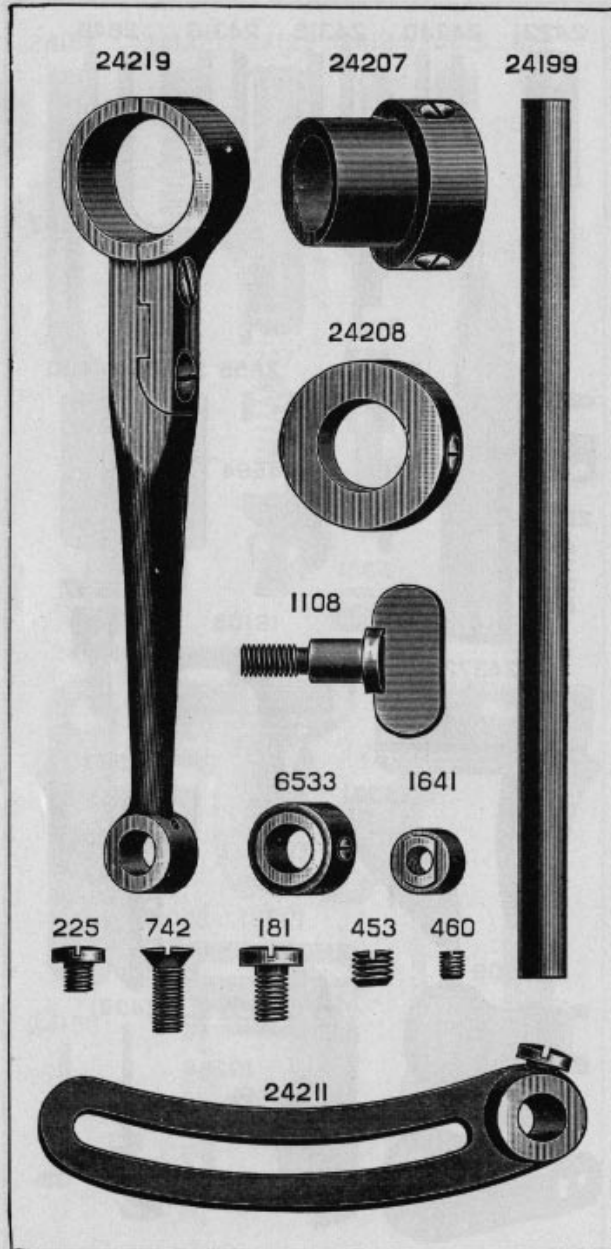


PLATE 1324—FULL SIZE

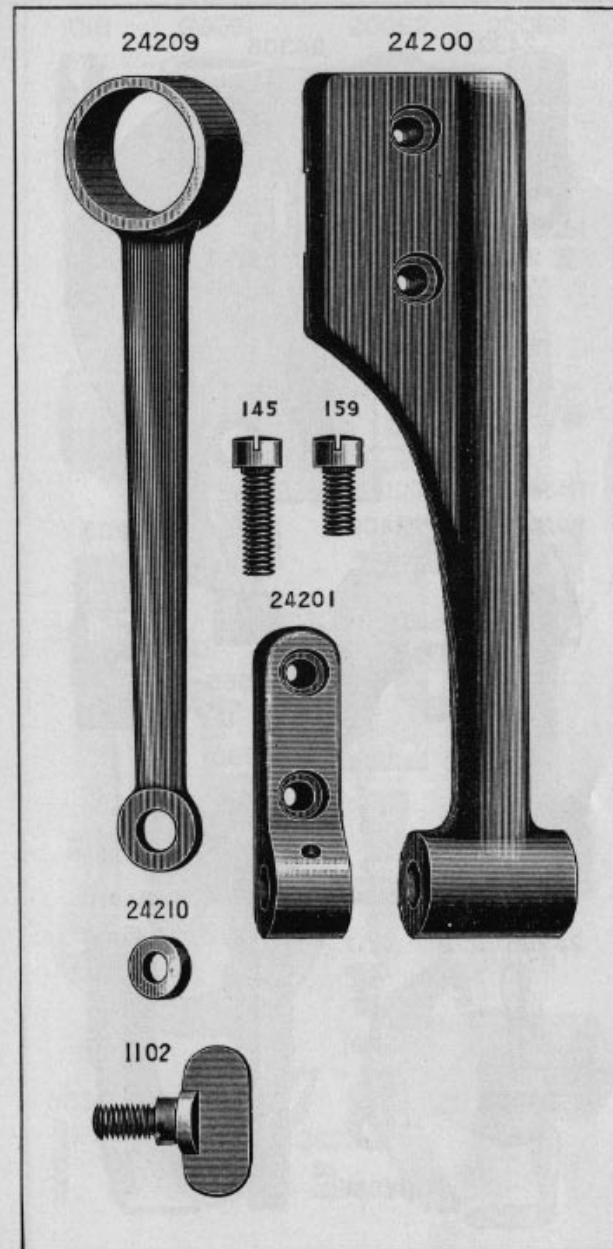


PLATE 1344—FULL SIZE

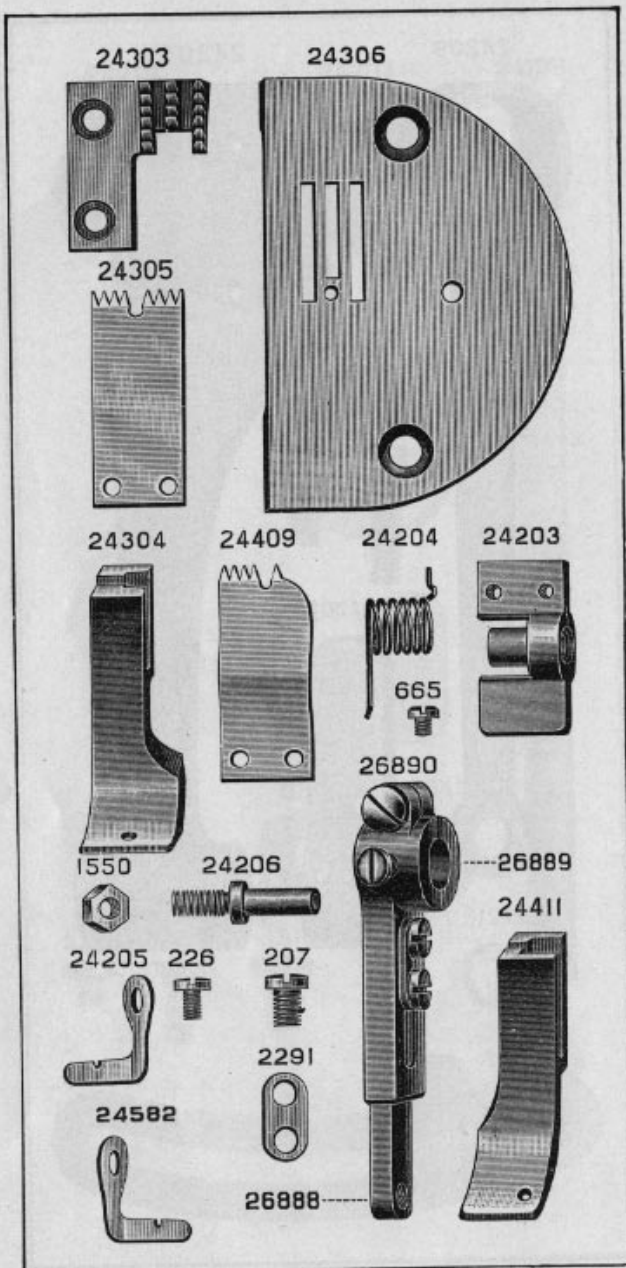


PLATE 1353—FULL SIZE

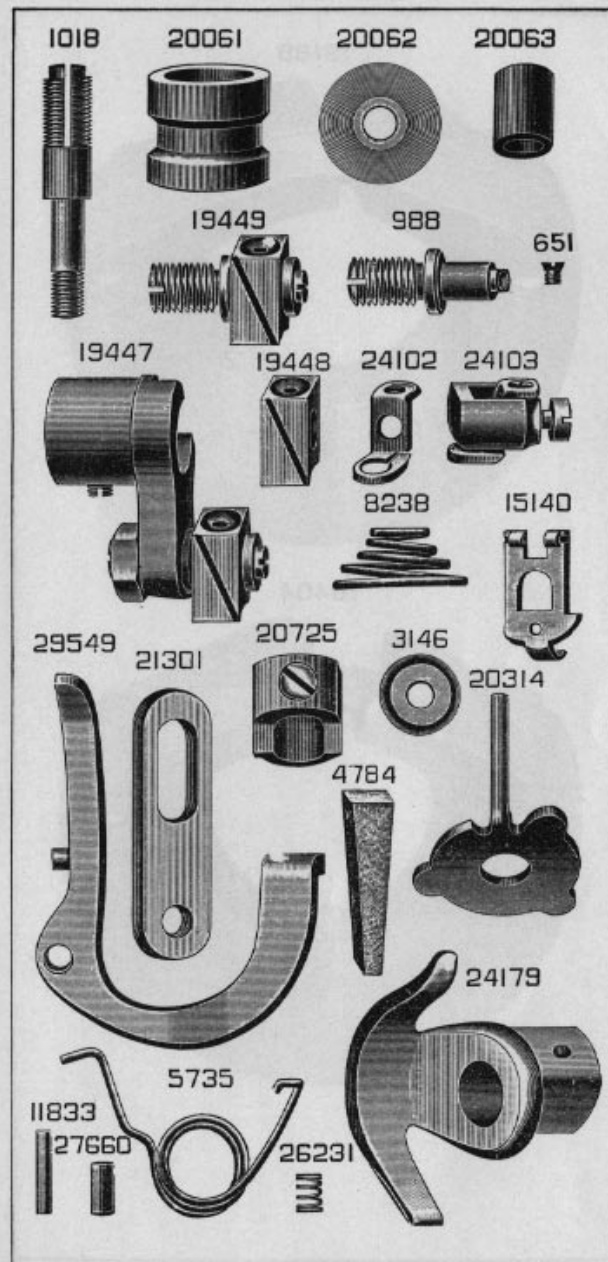
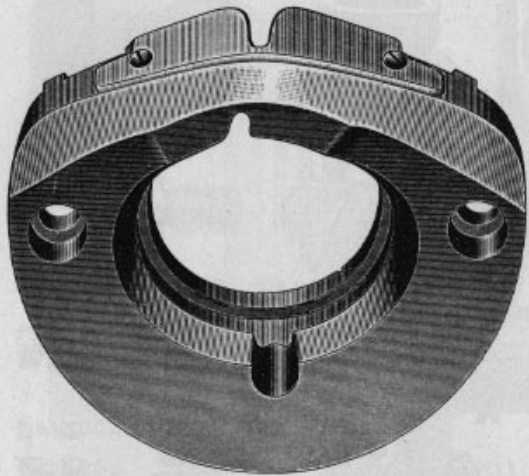


PLATE 1356—FULL SIZE

19188



19404

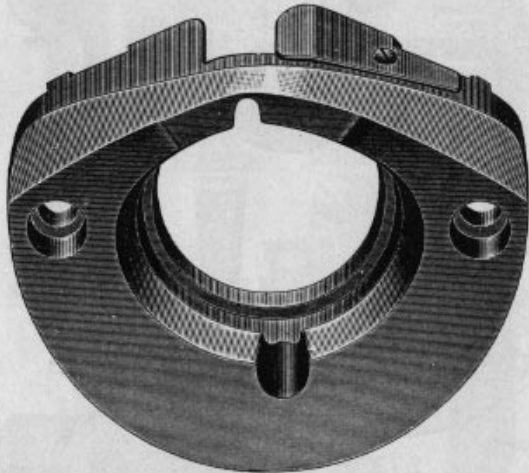
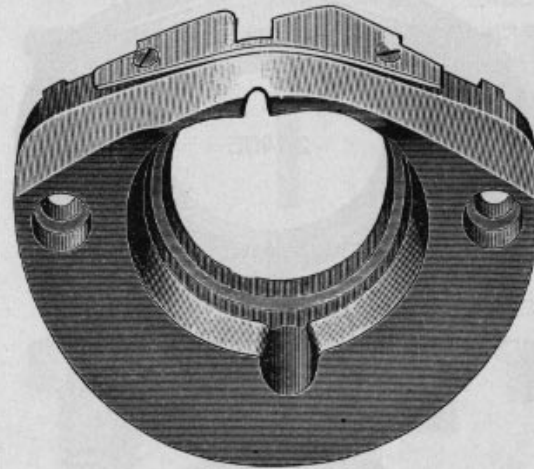


PLATE 1357—FULL SIZE

24010



24012

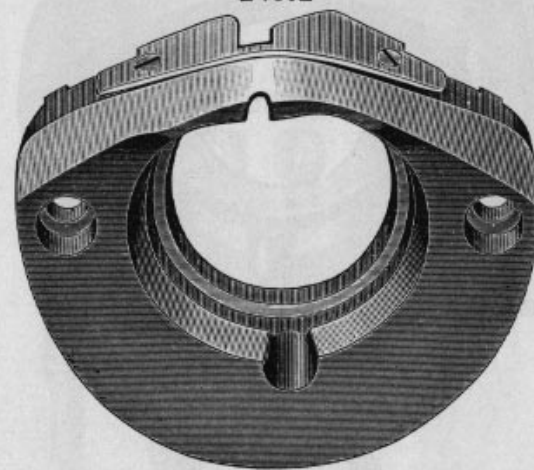


PLATE 1361—FULL SIZE

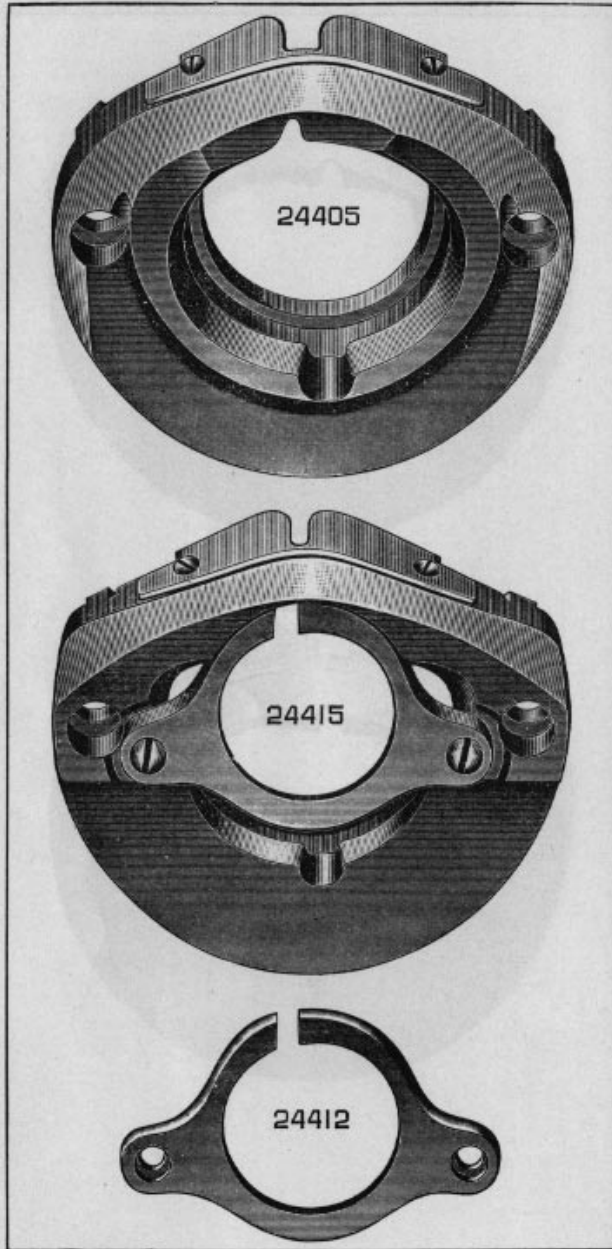


PLATE 1366—FULL SIZE

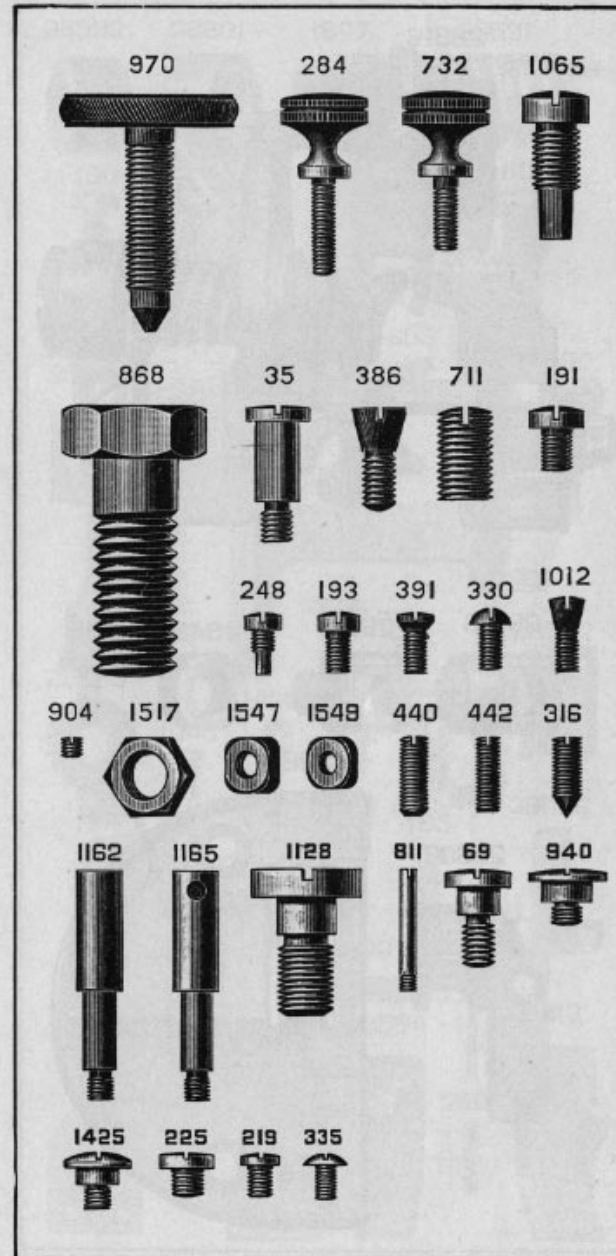




PLATE 1370—FULL SIZE

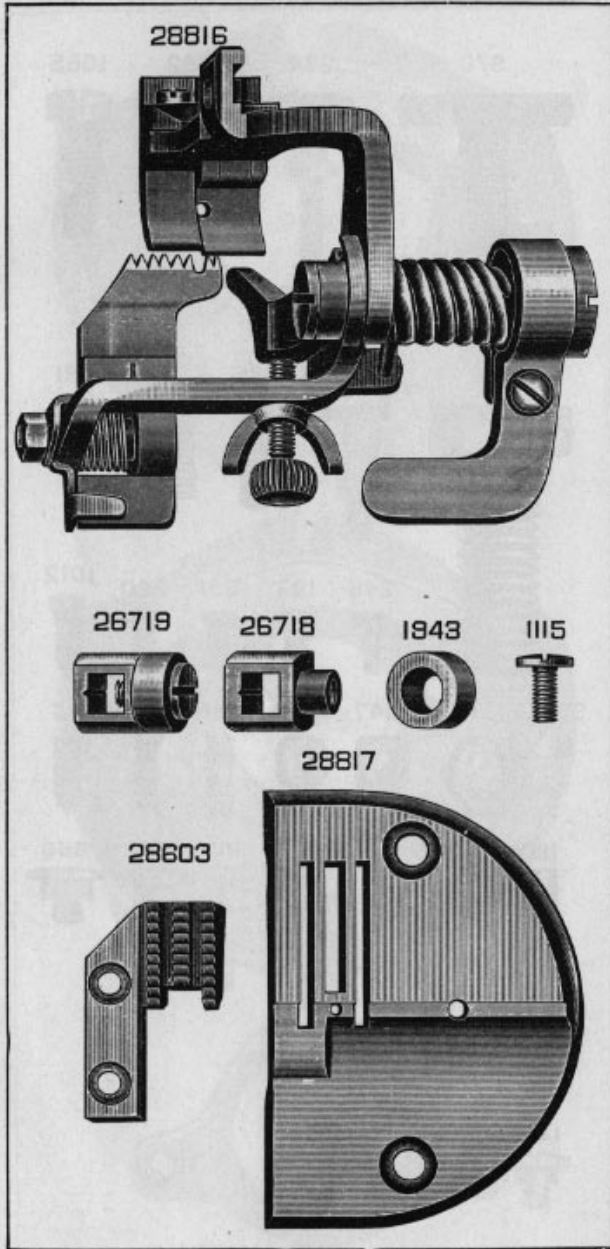


PLATE 1371—FULL SIZE

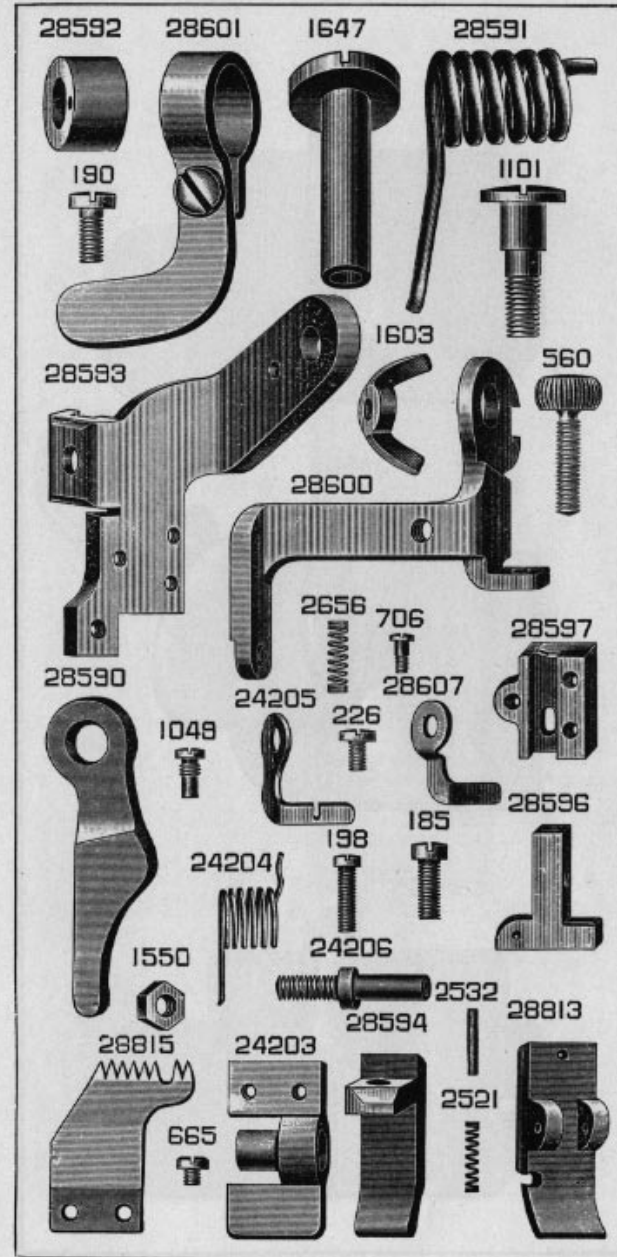
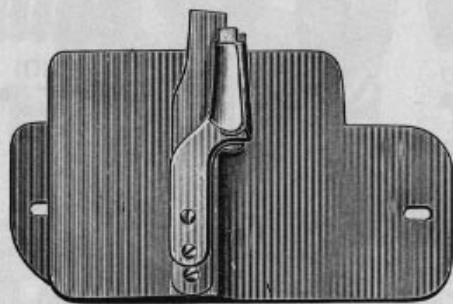
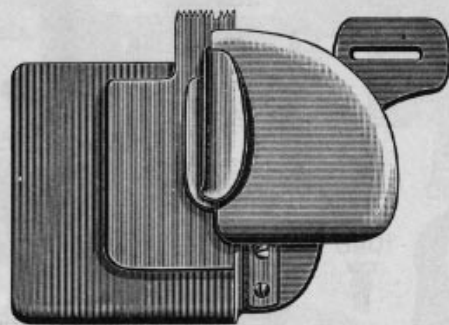


PLATE 1372—ONE-HALF SIZE

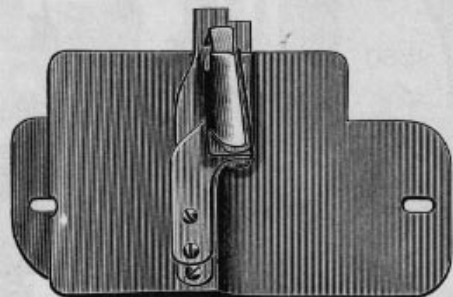
28606



28605



28818



51809



94



207



233



2362



190



220



12152



36760

26805

26810

26809

26808

26806

26803

26807

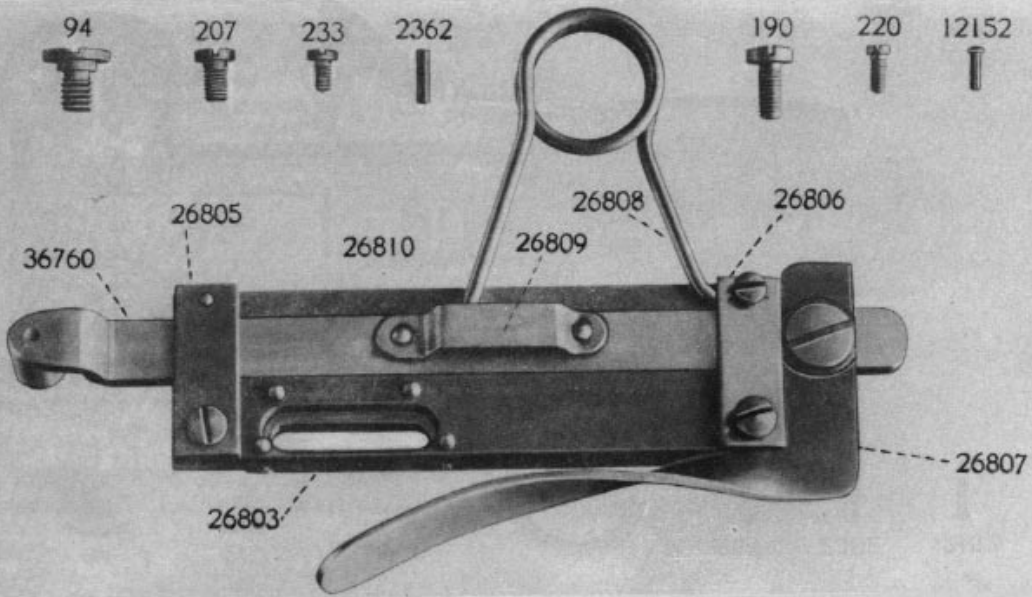


PLATE 1375-FULL SIZE

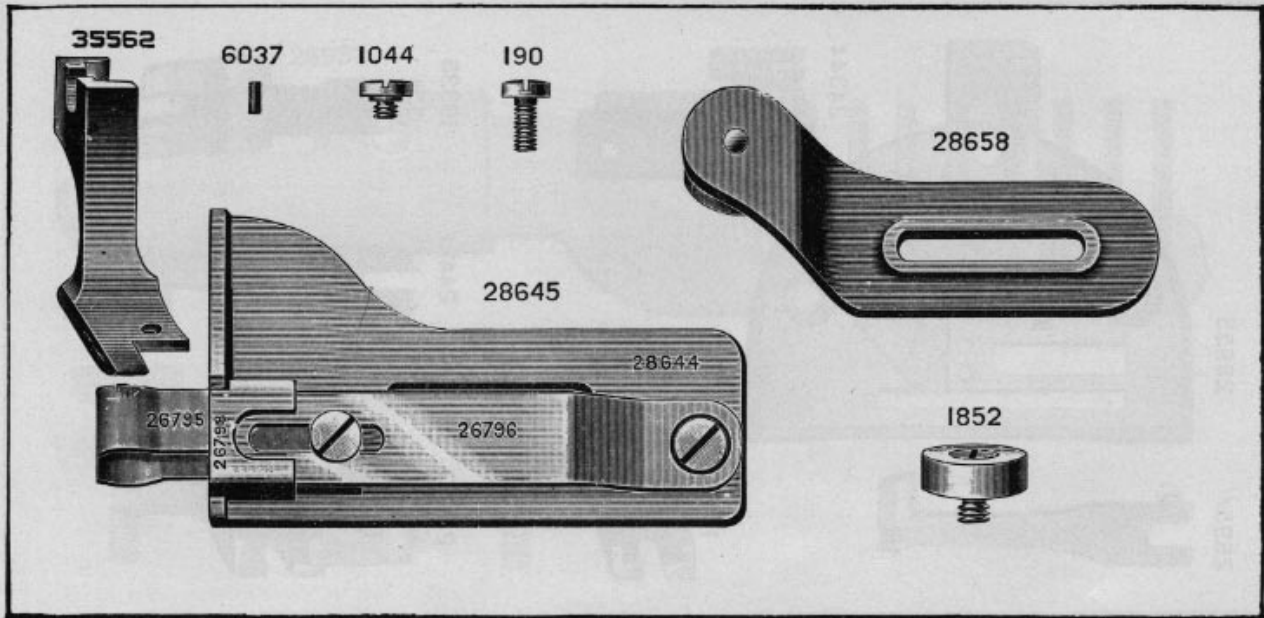
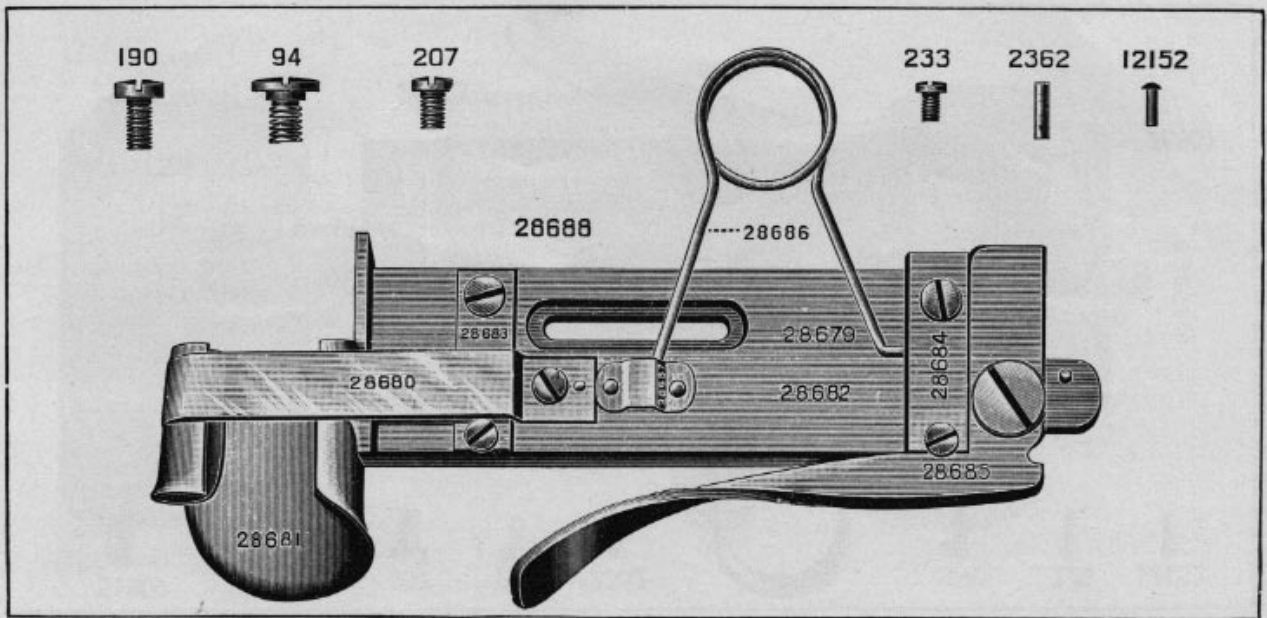


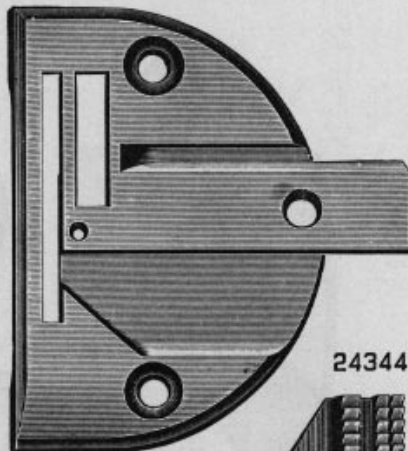


PLATE 1378—FULL SIZE

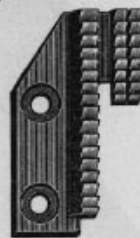
26954



26955



24344



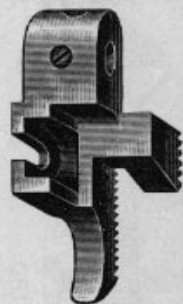
19376



7298



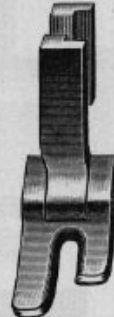
24480



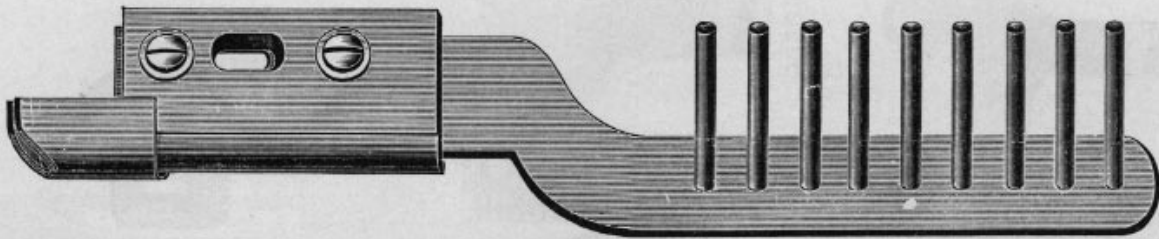
24481



19336



26953



283



193



7071



898

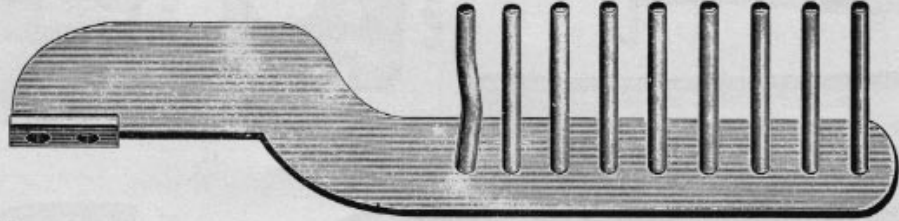


PLATE 1379—FULL SIZE

233



28337



28334

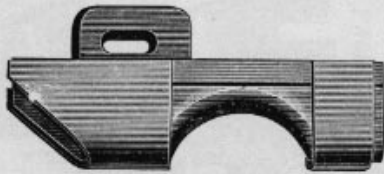
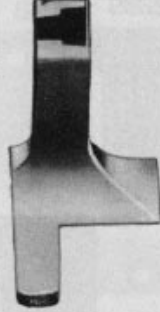


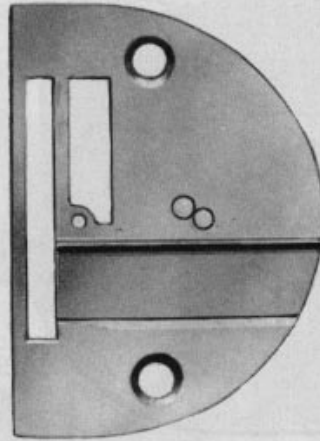
PLATE 1380—FULL SIZE

PLATE 1381—FULL SIZE

28676



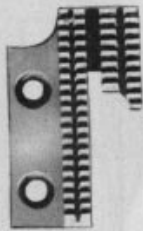
28677



120208



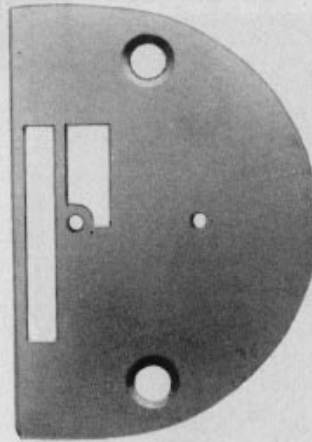
26603



120001



44137



44136

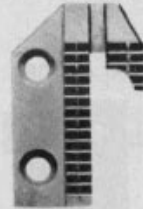


PLATE 1382—FULL SIZE

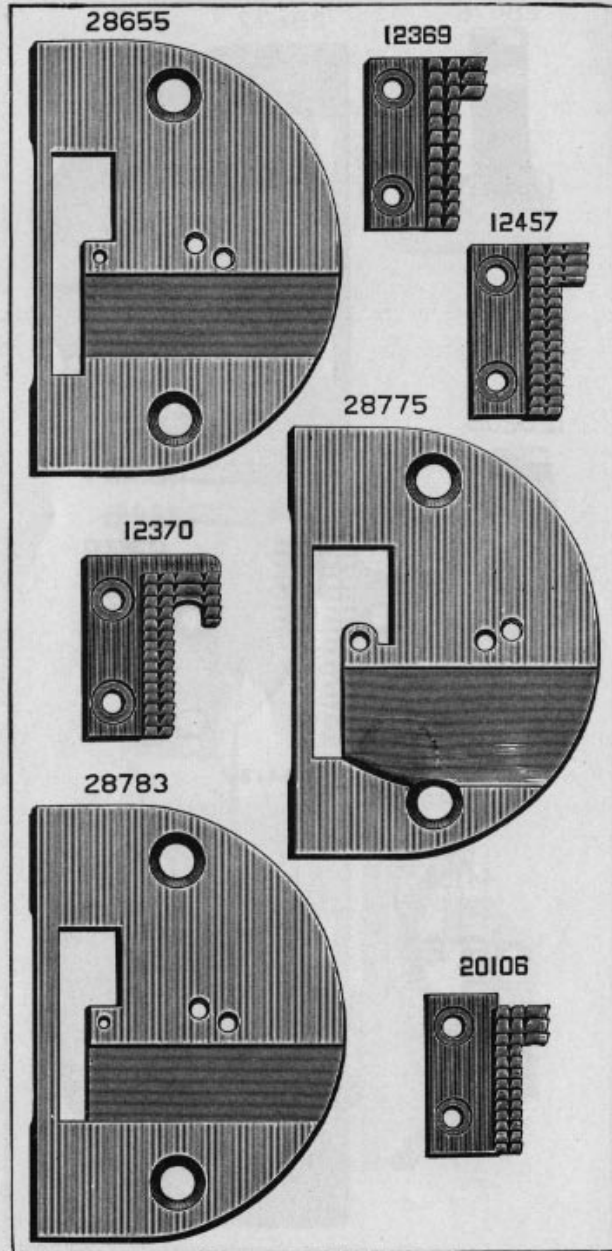


PLATE 1383—FULL SIZE

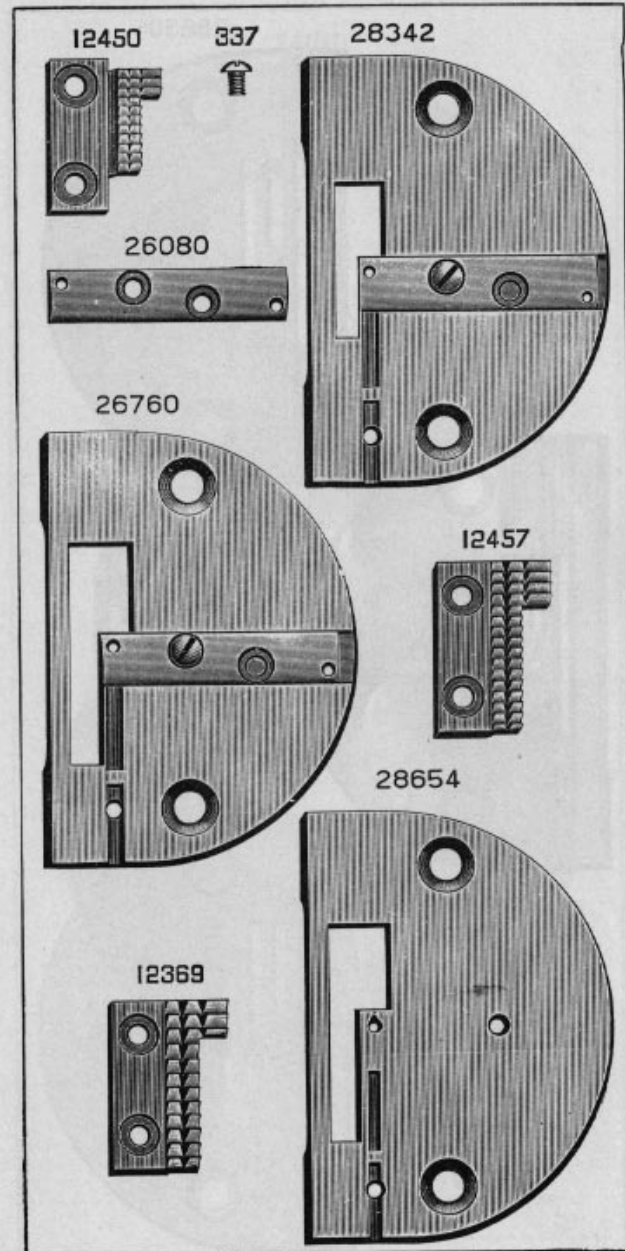
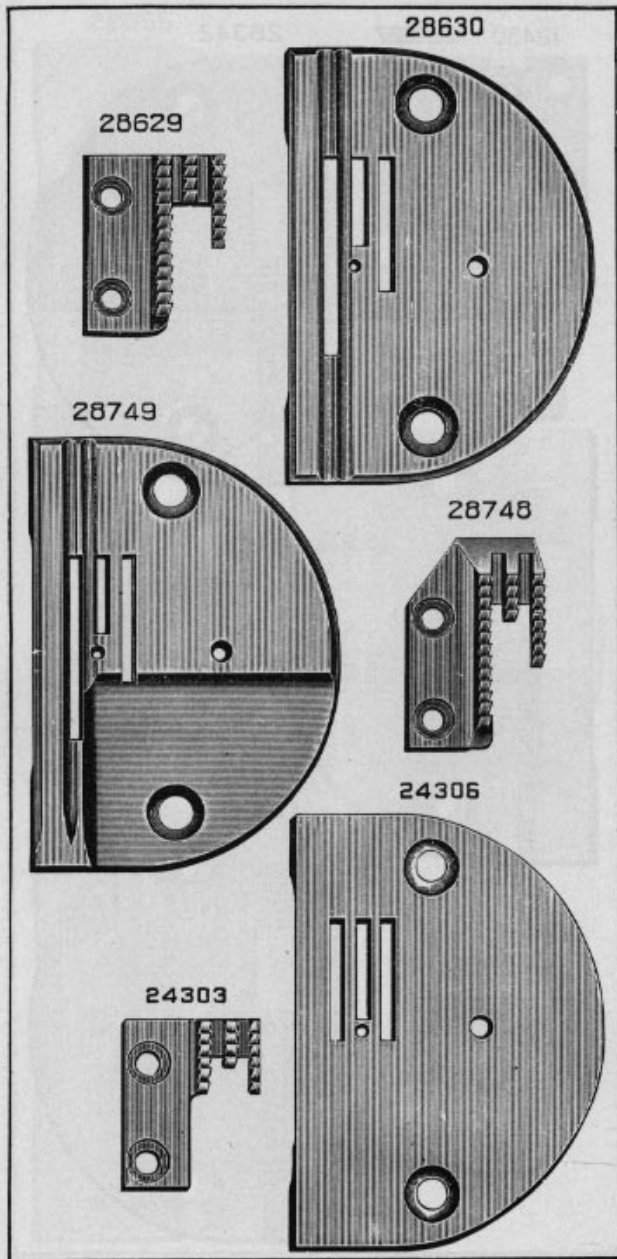


PLATE 1384—FULL SIZE



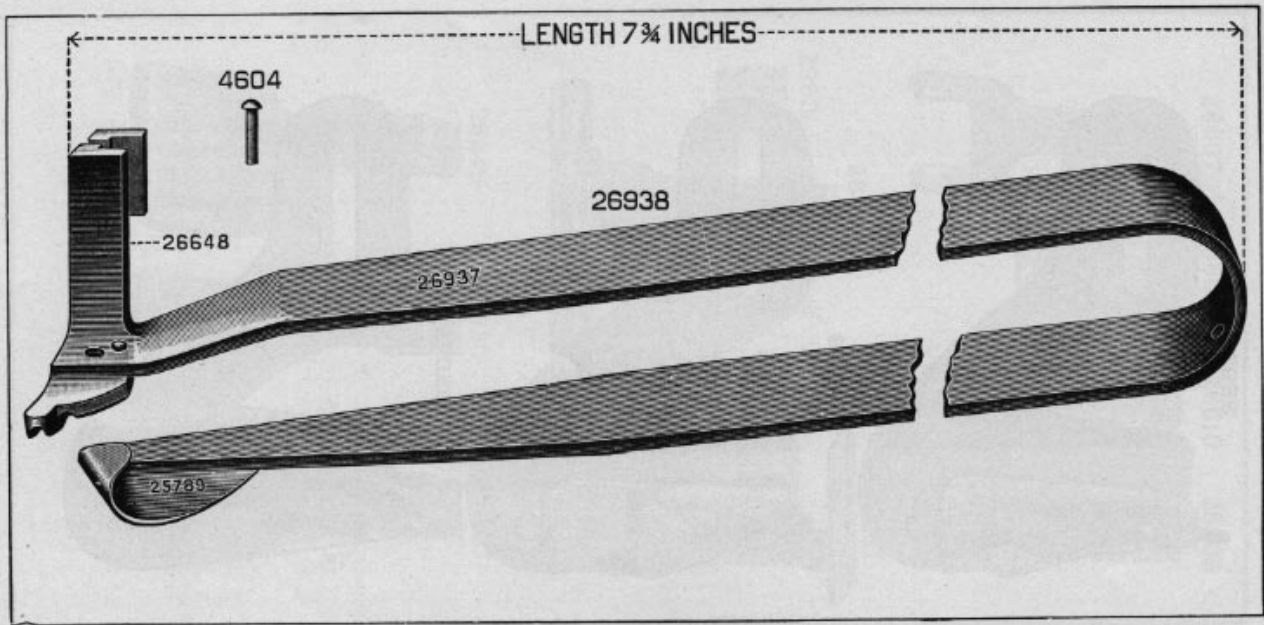


PLATE 1385—FULL SIZE



PLATE 1386—FULL SIZE

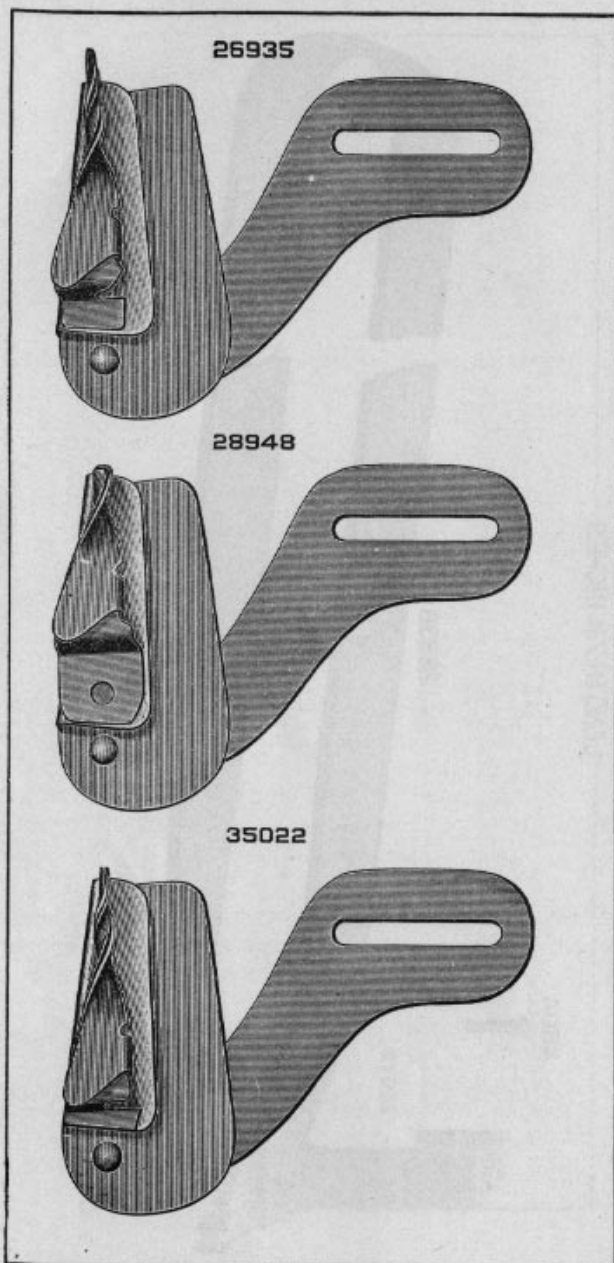


PLATE 1387—FULL SIZE

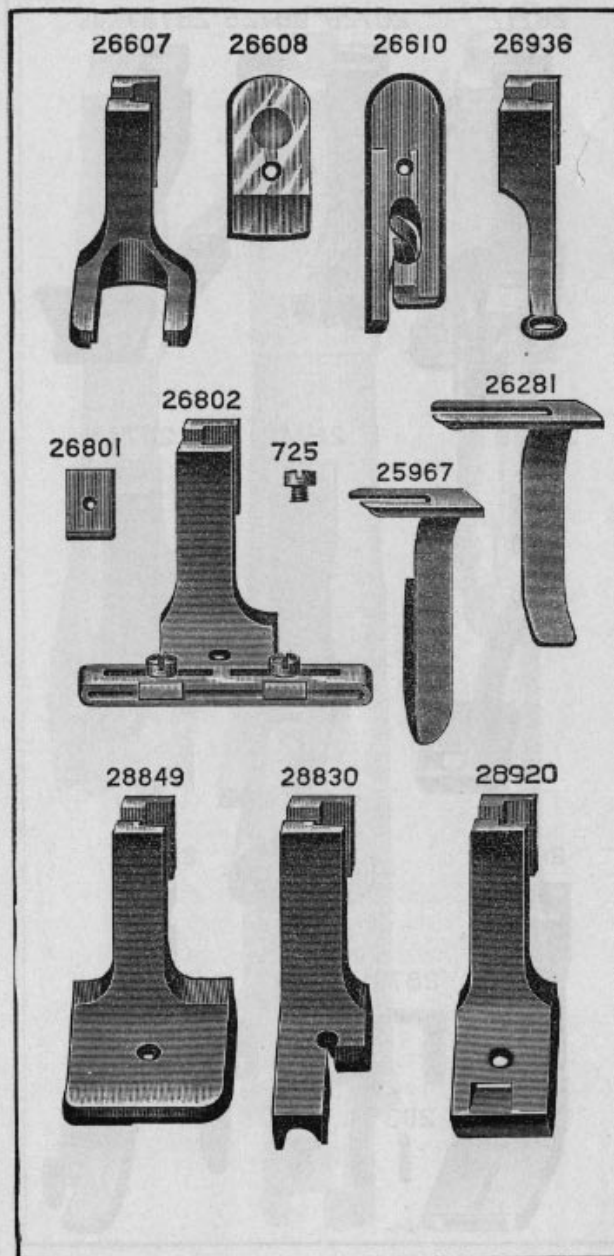




PLATE 1388—FULL SIZE

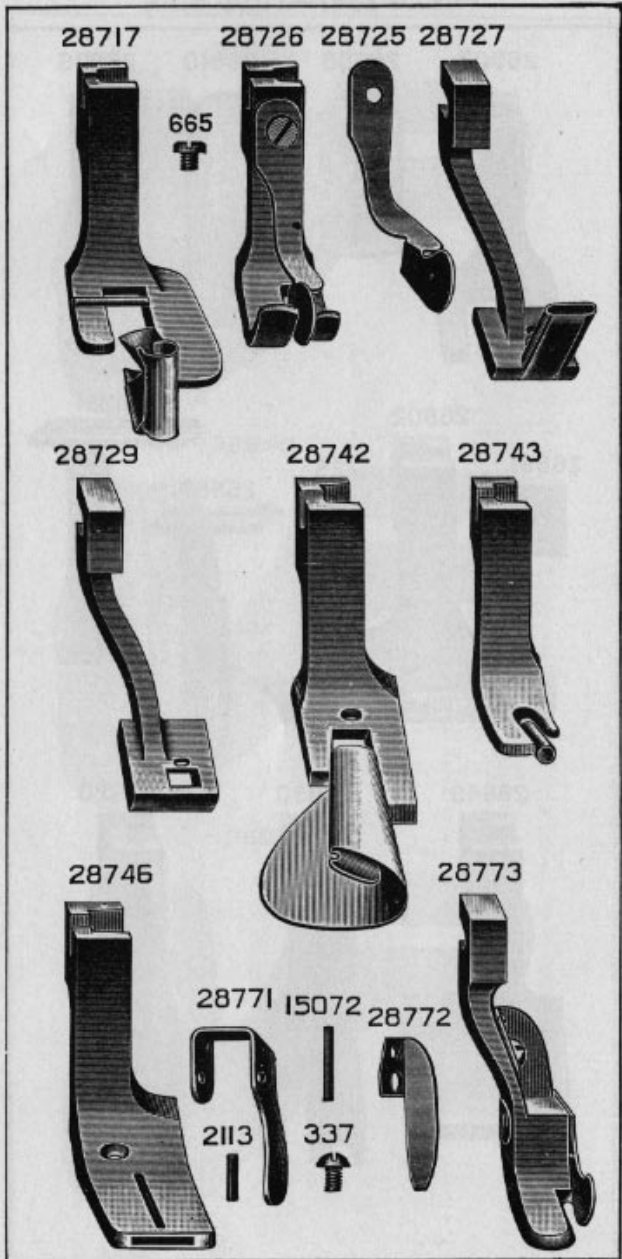


PLATE 1389—FULL SIZE

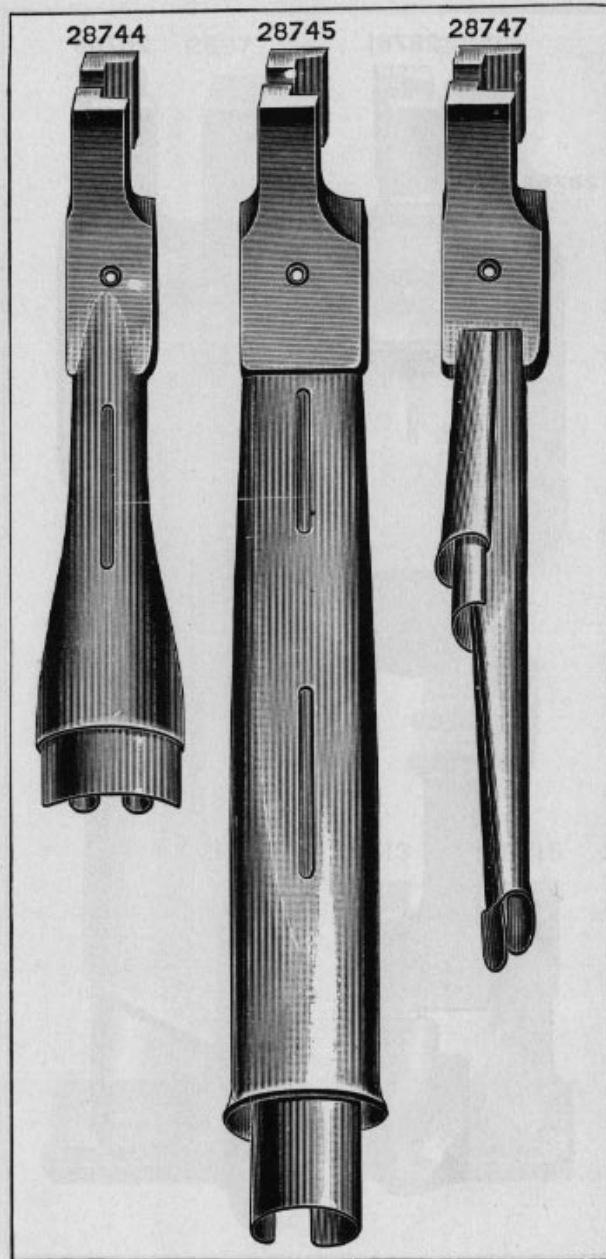


PLATE 1390—FULL SIZE

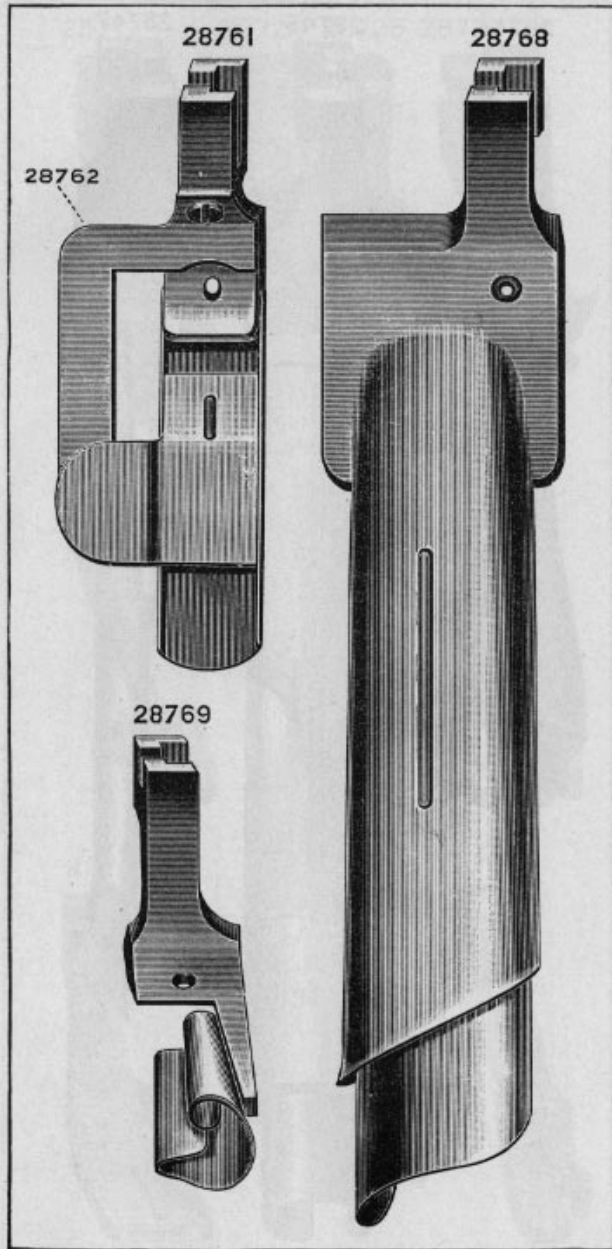
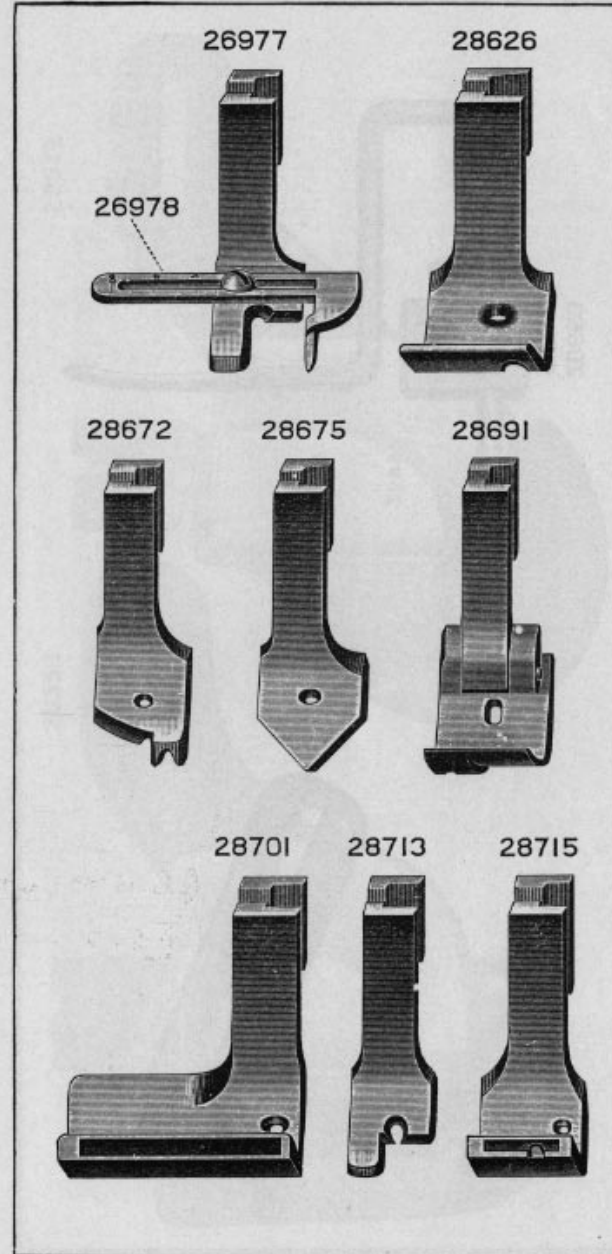


PLATE 1391—FULL SIZE



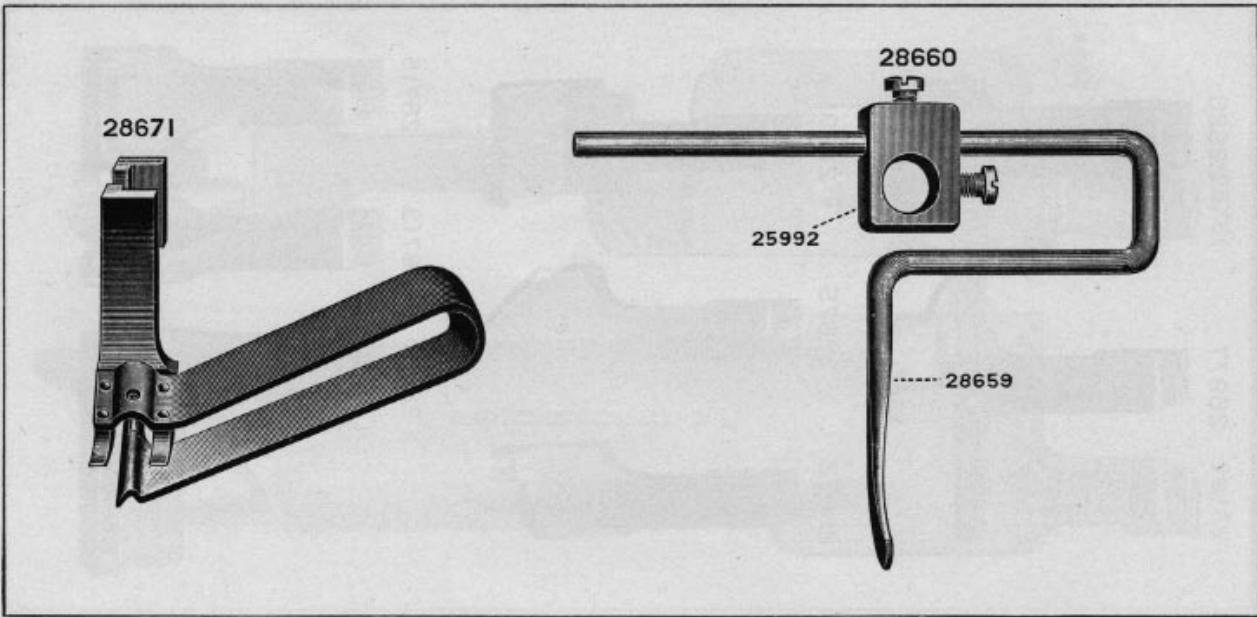


PLATE 1392—FULL SIZE

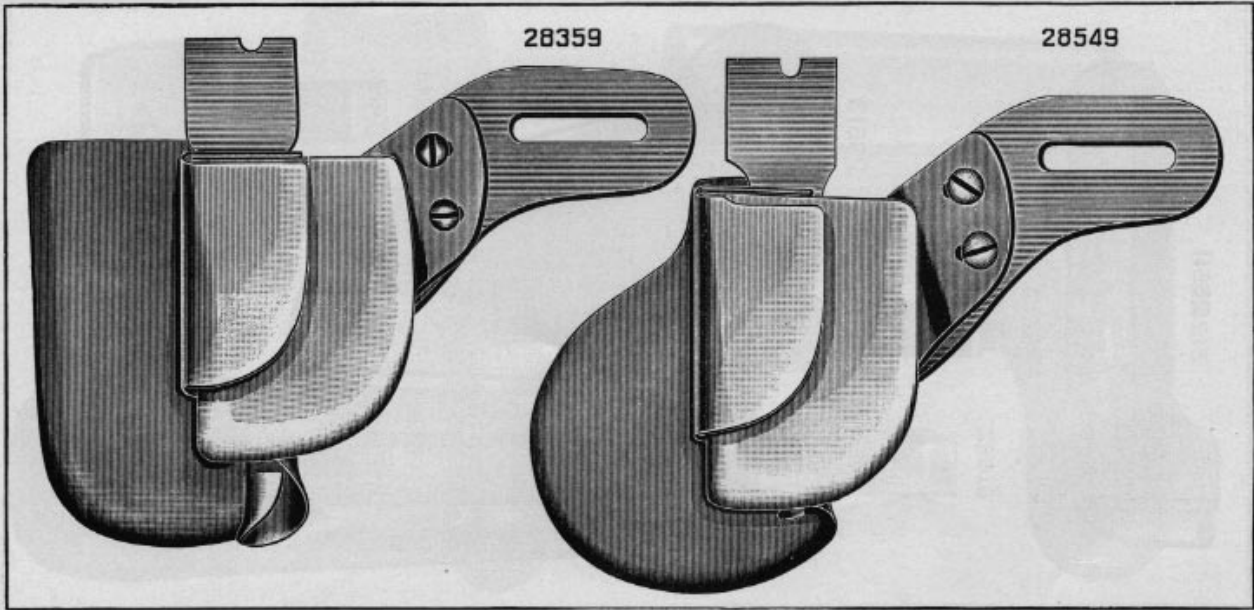


PLATE 1395—FULL SIZE

PLATE 1396—FULL SIZE

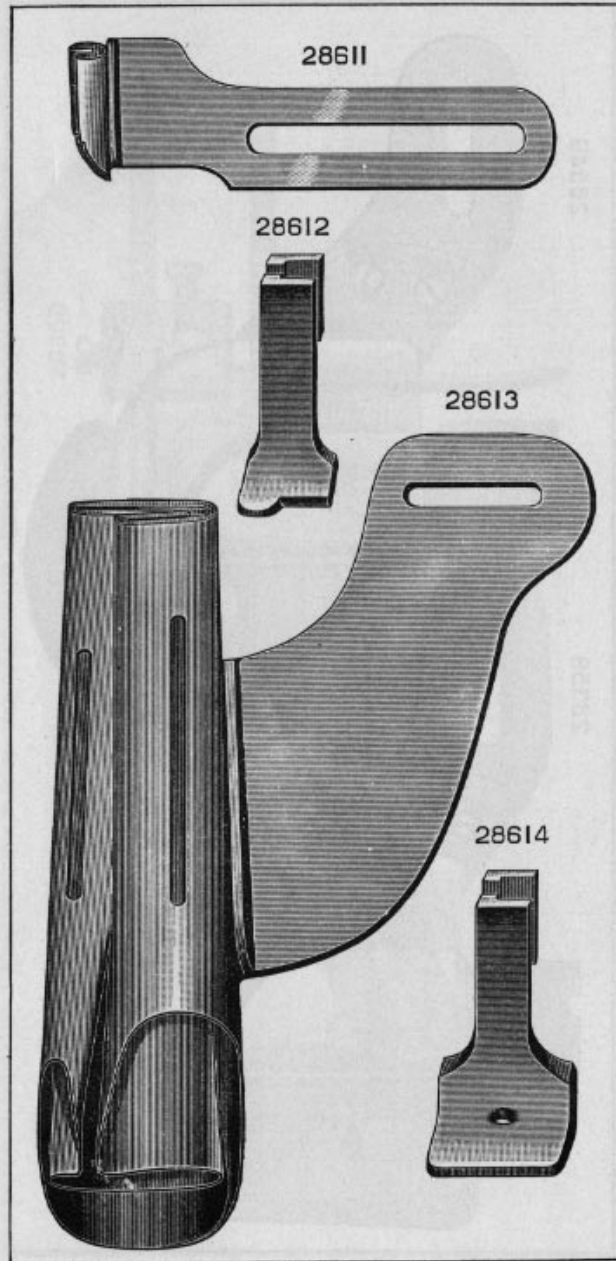


PLATE 1397—FULL SIZE

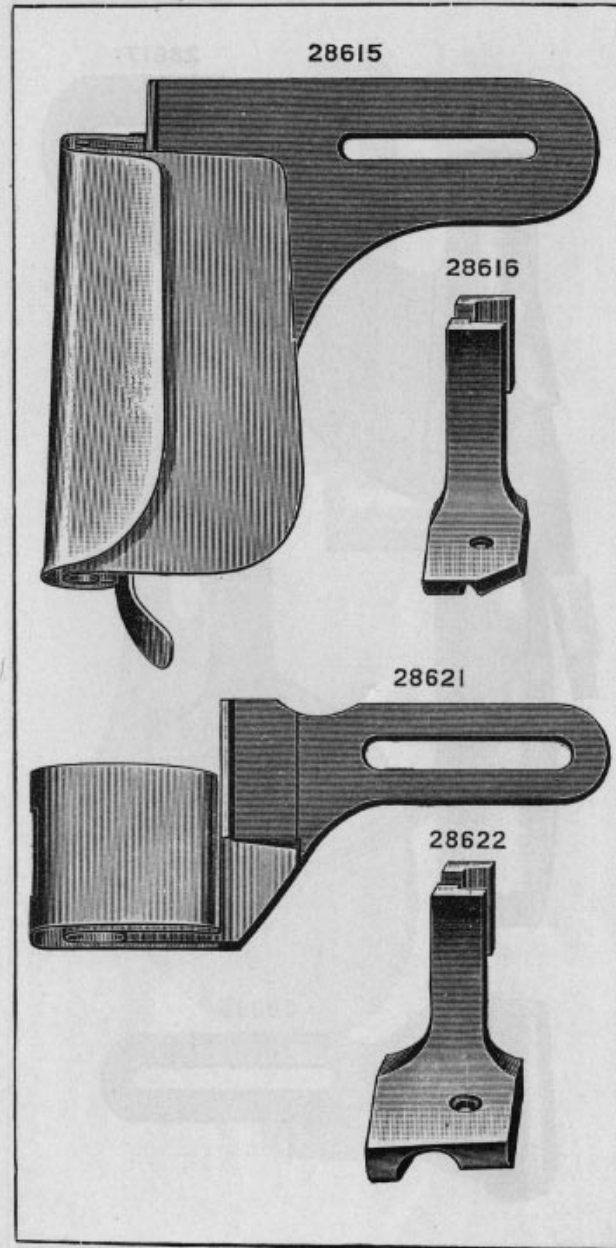
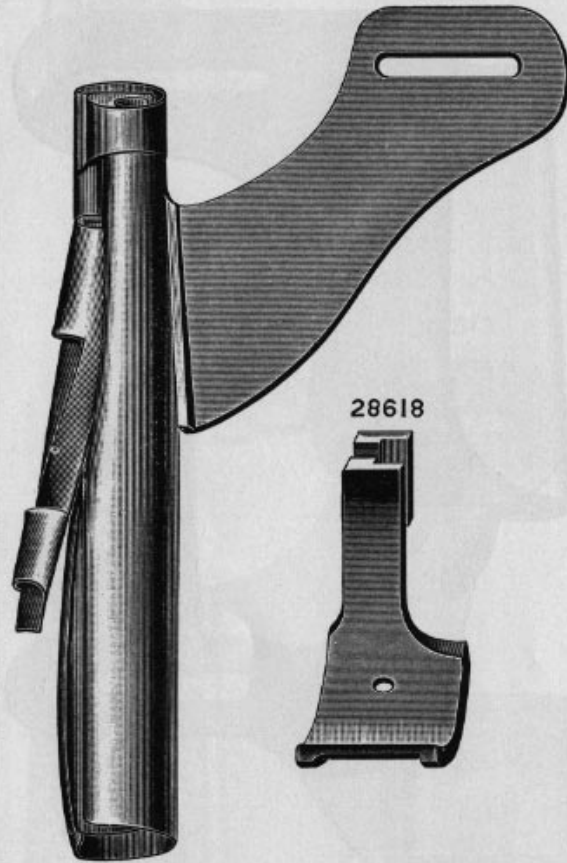


PLATE 1398—FULL SIZE

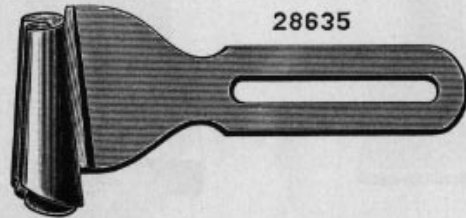
28617



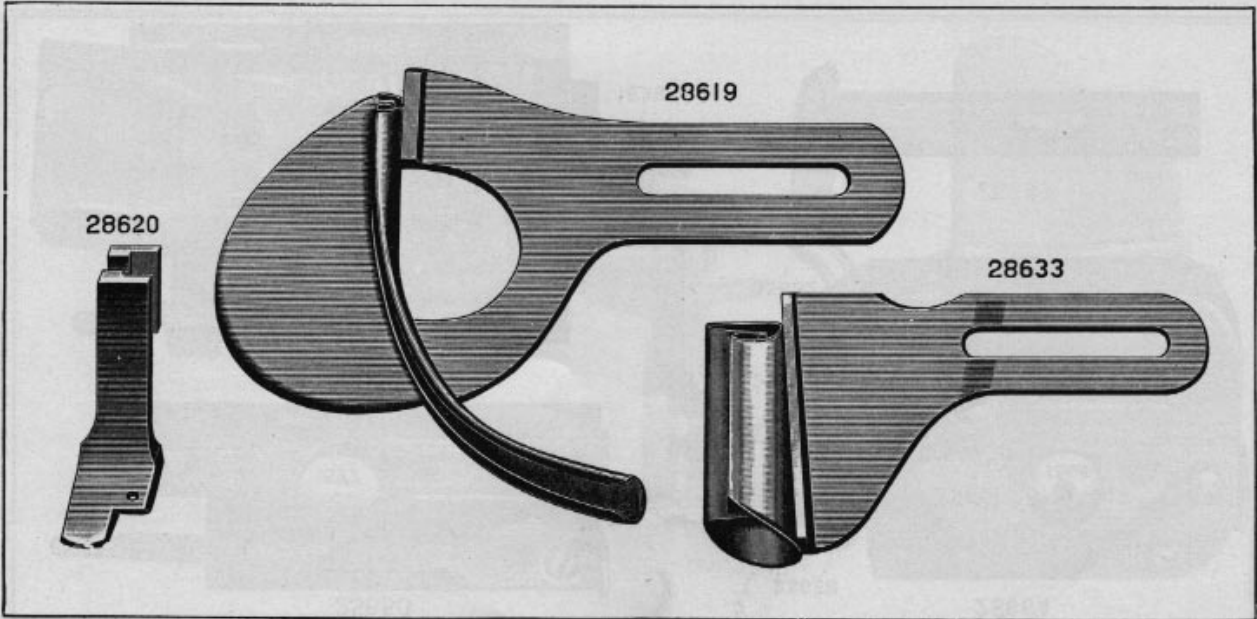
28618



28635







28620

28619

28633

PLATE 1399—FULL SIZE

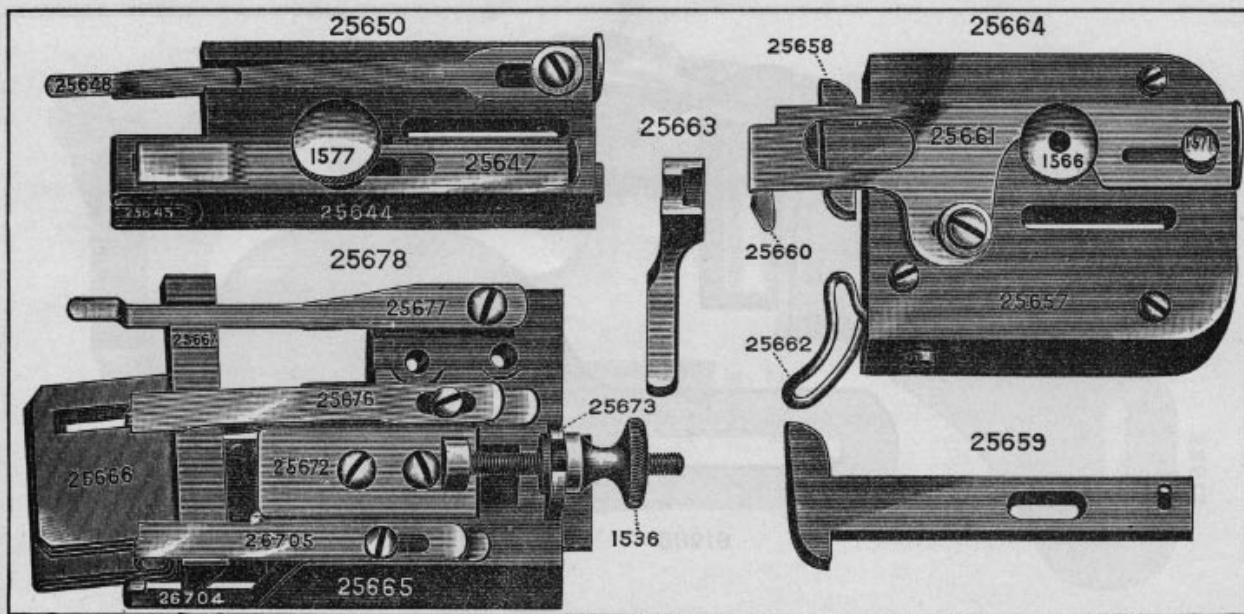
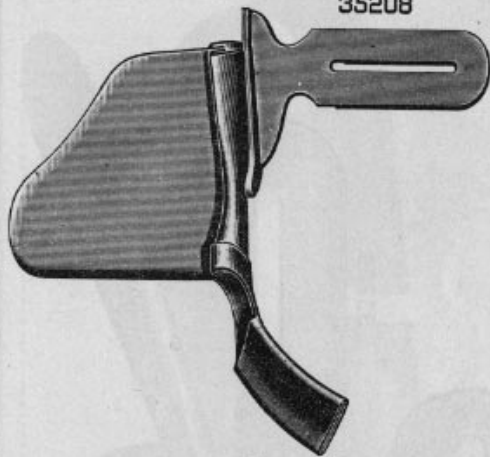


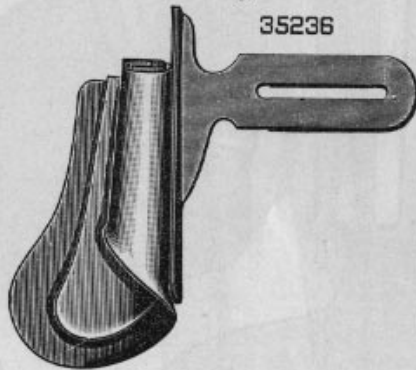
PLATE 1949—FULL SIZE

PLATE 1971—ONE-HALF SIZE

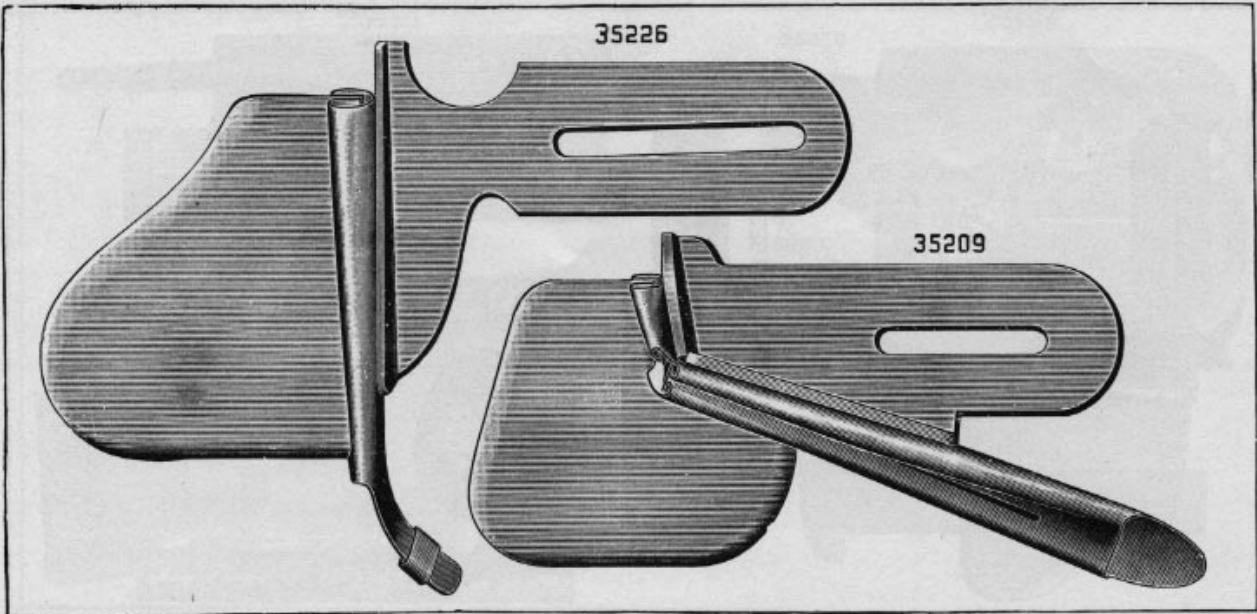
35208



35236







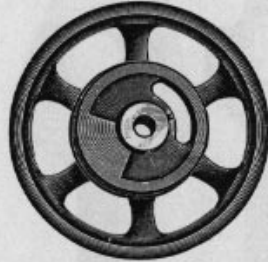
35226

35209

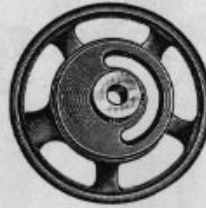
PLATE 1972—FULL SIZE

PLATE 2000—ONE-FOURTH SIZE

4370



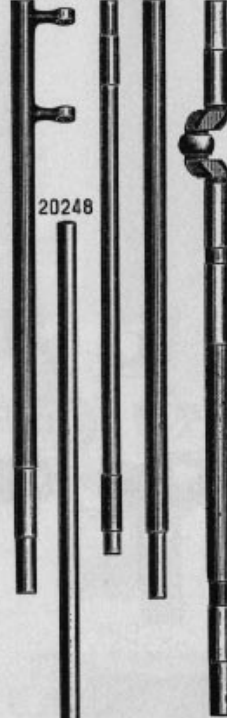
12358



2135



20238 20257 20006 20210



20248



12367



20212



19267



20233

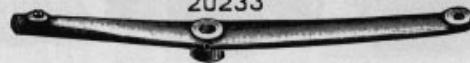


PLATE 2001—ONE-HALF SIZE

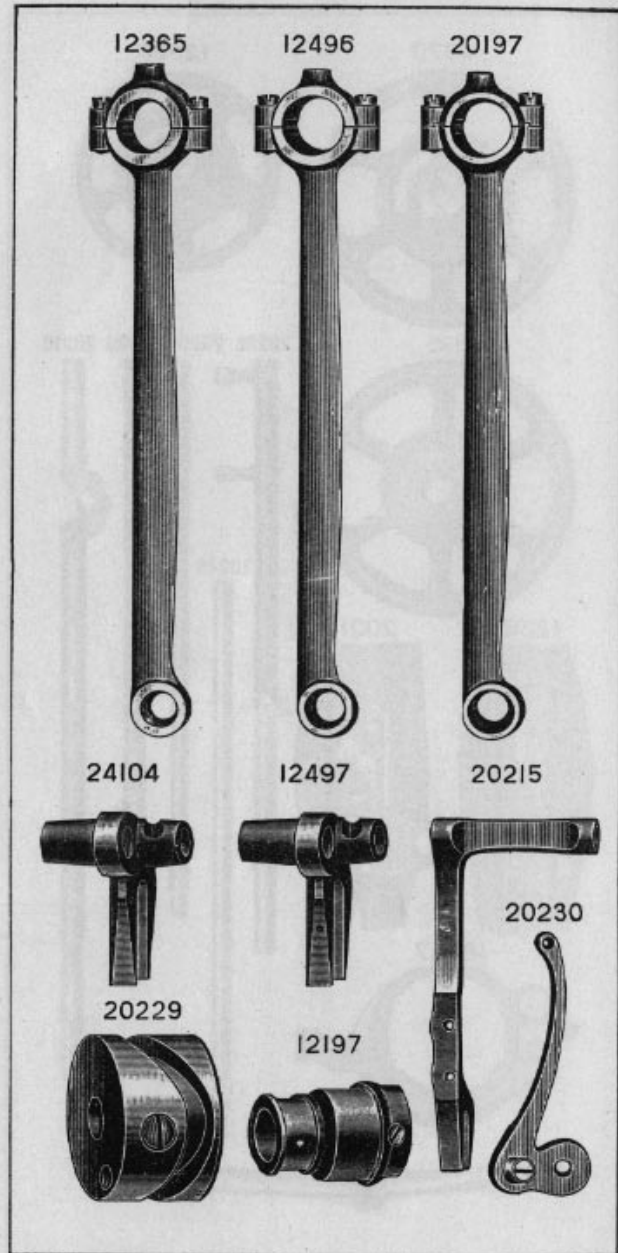


PLATE 2002—ONE-HALF SIZE

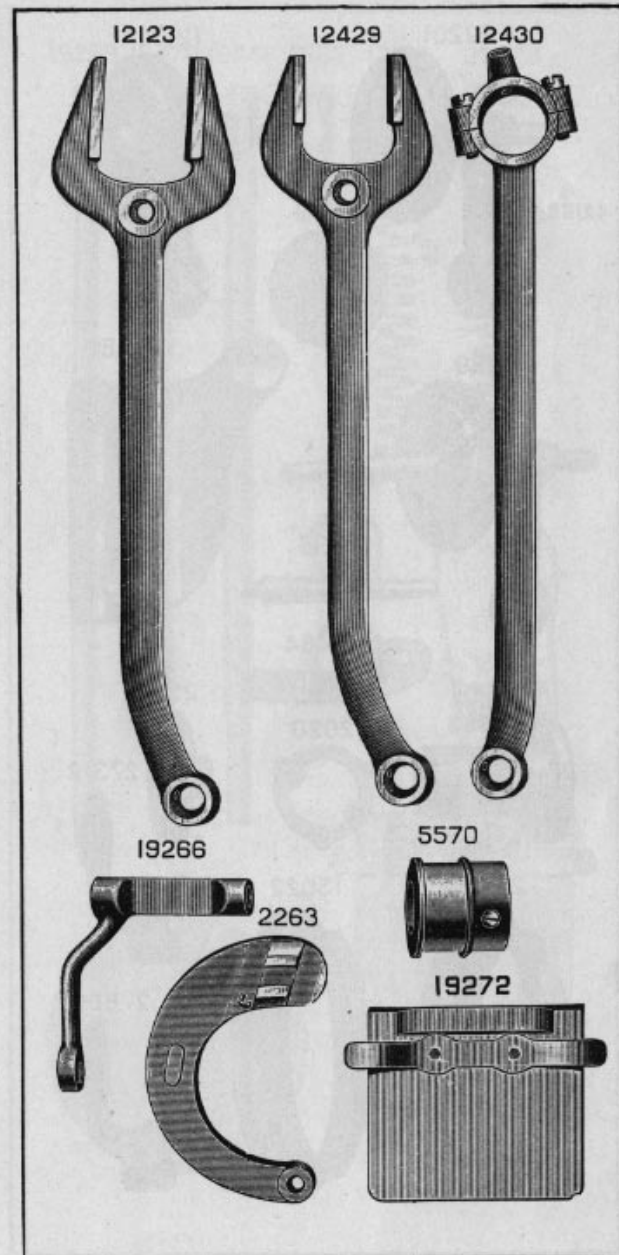


PLATE 2003—ONE-HALF SIZE

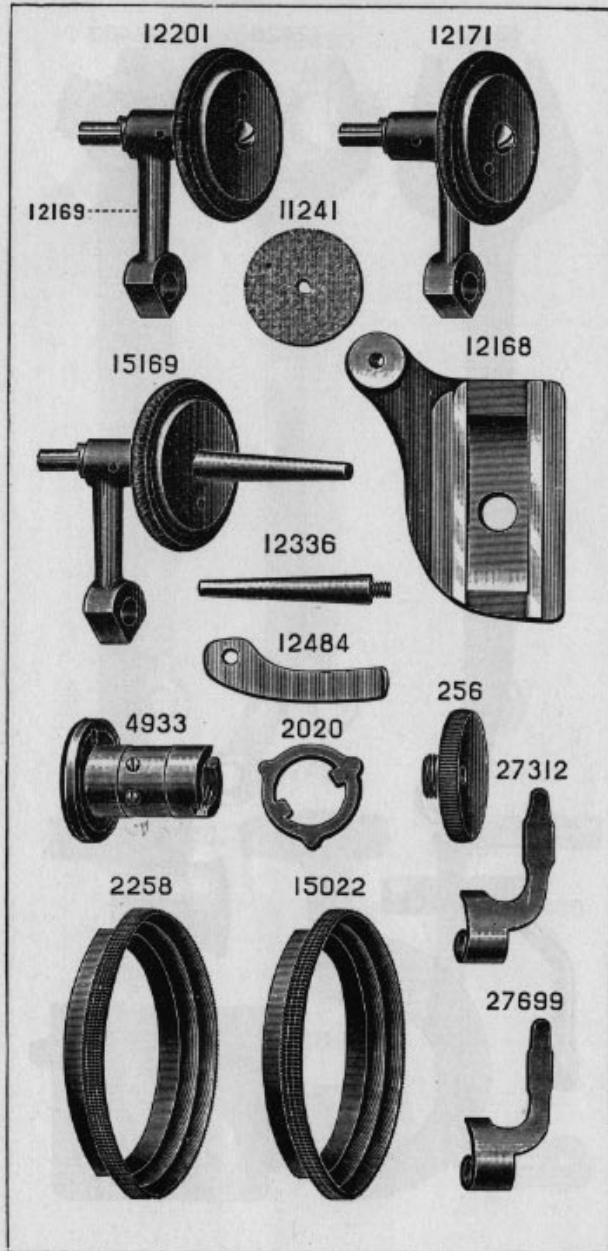


PLATE 2004—ONE-HALF SIZE

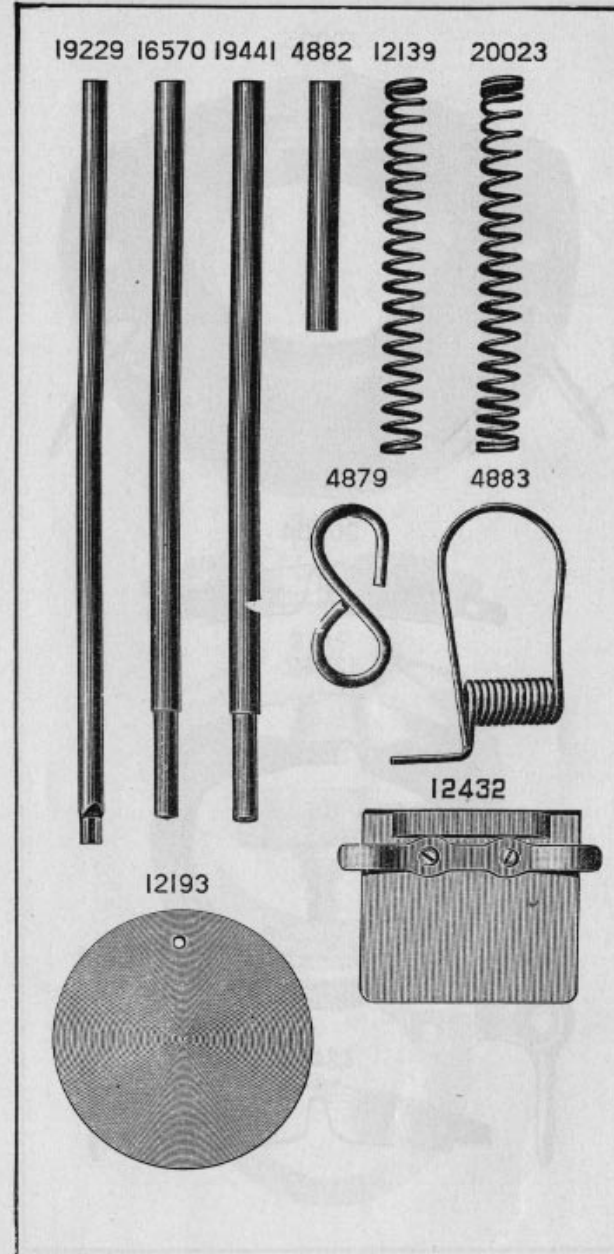
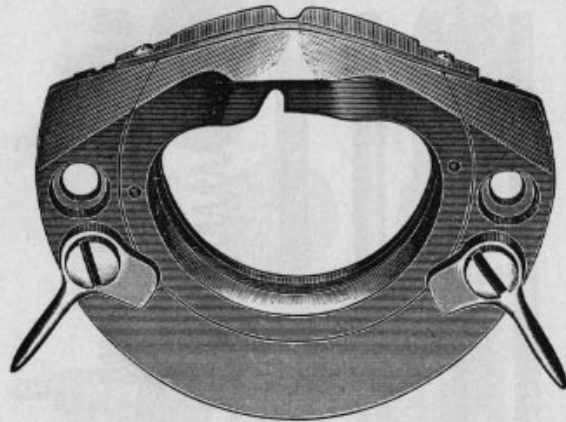


PLATE 2005—FULL SIZE

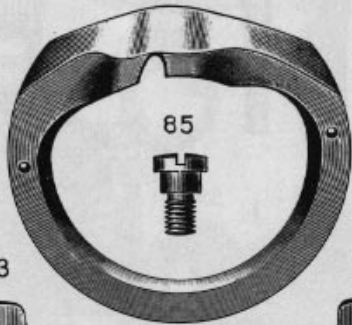
20005



20004



12492



85



12493



12494

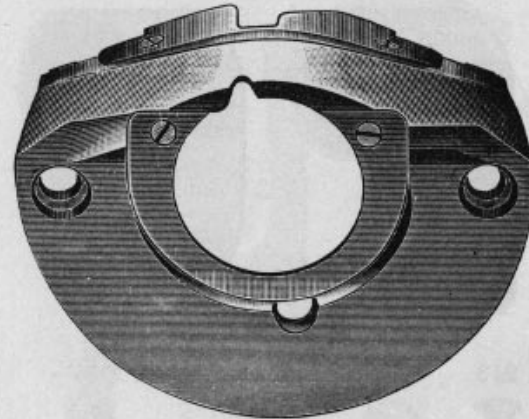


12491

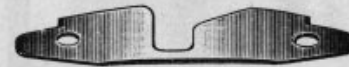


PLATE 2006—FULL SIZE

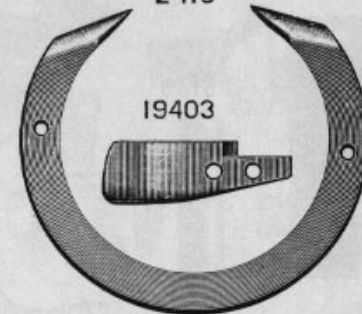
24120



24009



2419



19403



24117



1053





PLATE 2009—FULL SIZE

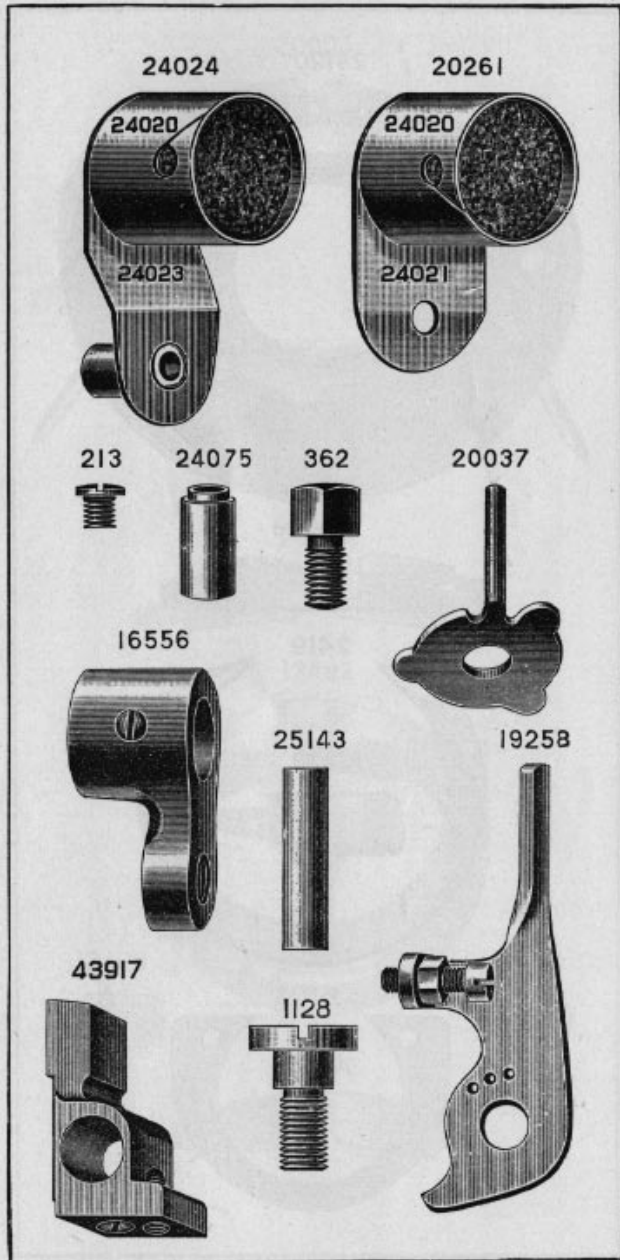


PLATE 2011—FULL SIZE

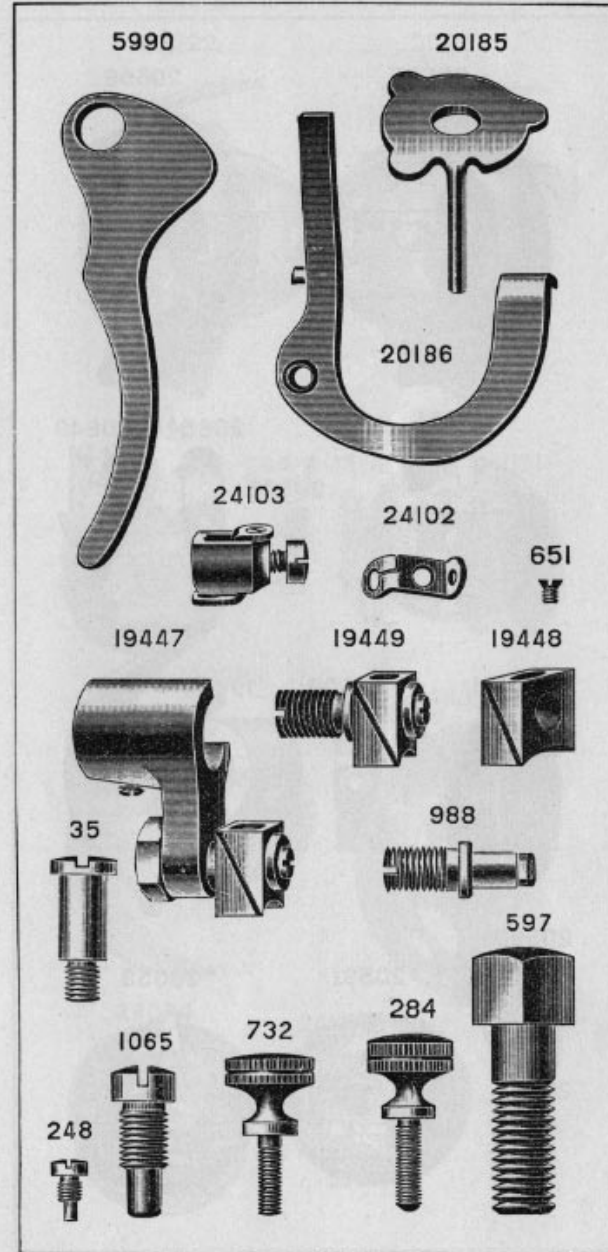


PLATE 2012—FULL SIZE

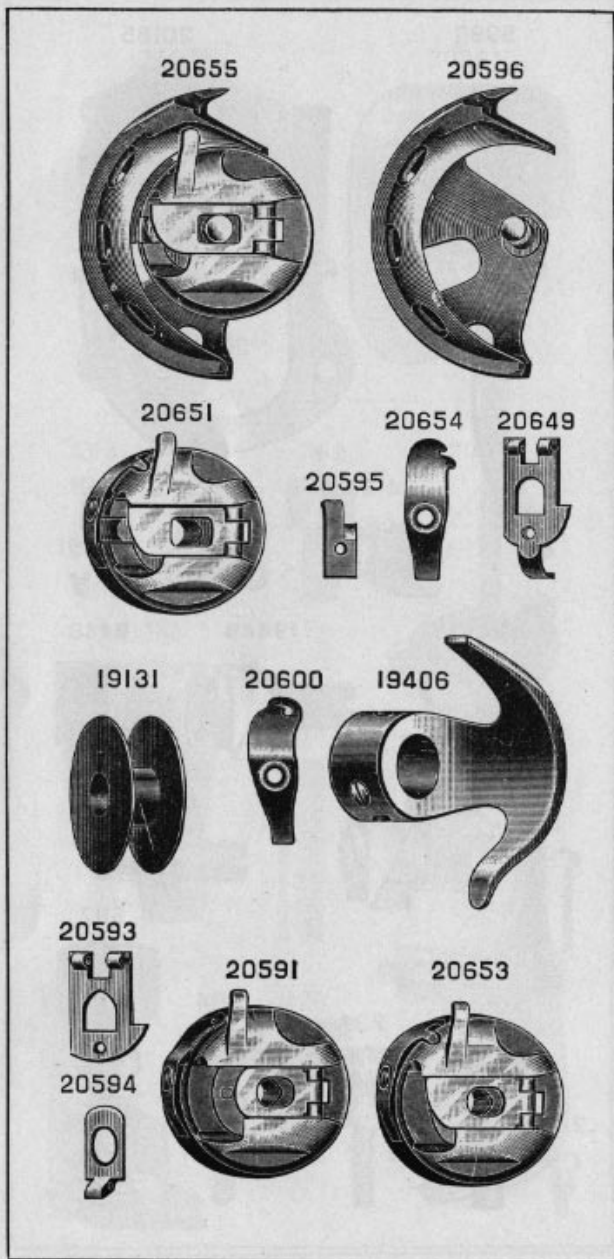


PLATE 2013—FULL SIZE

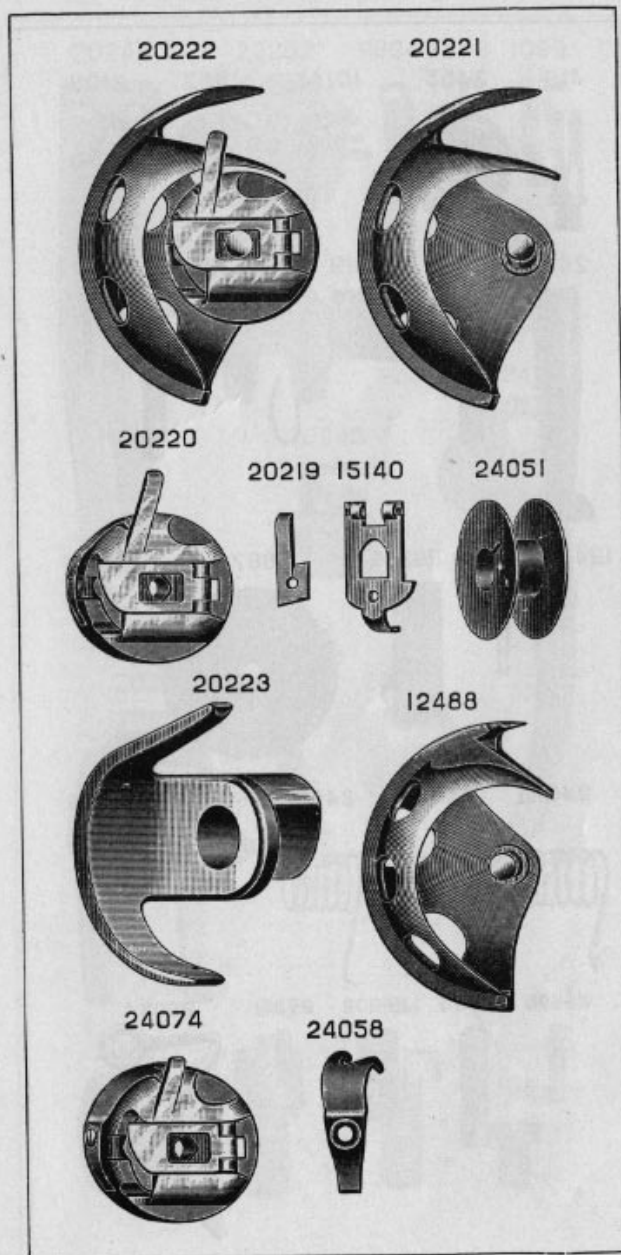


PLATE 2014—FULL SIZE

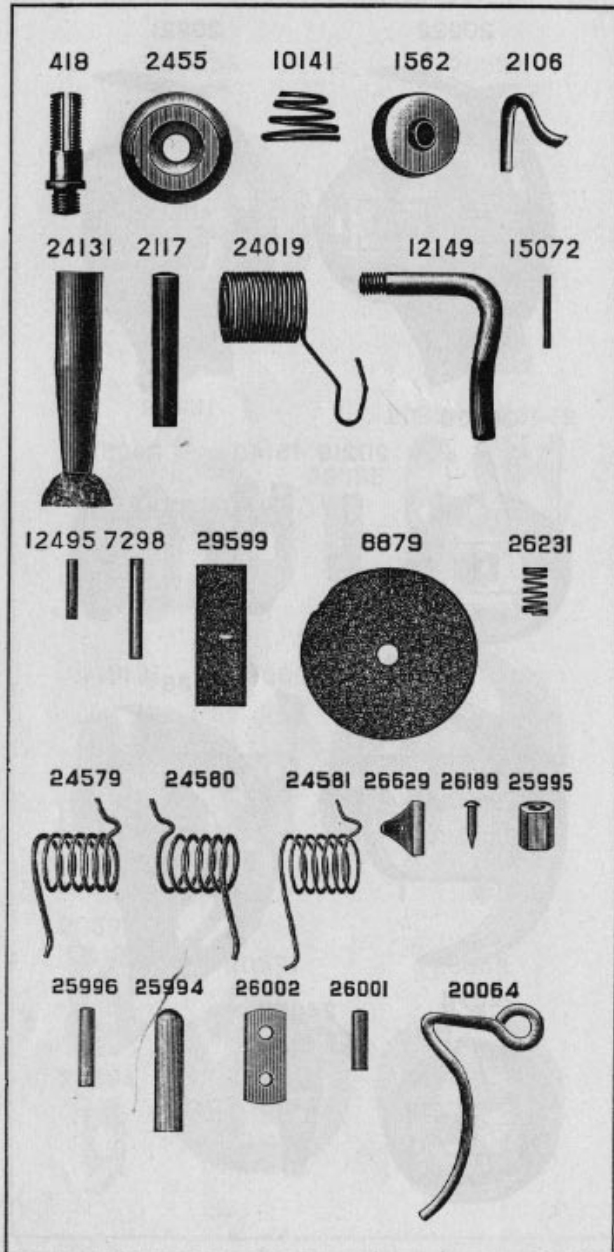


PLATE 2019—FULL SIZE

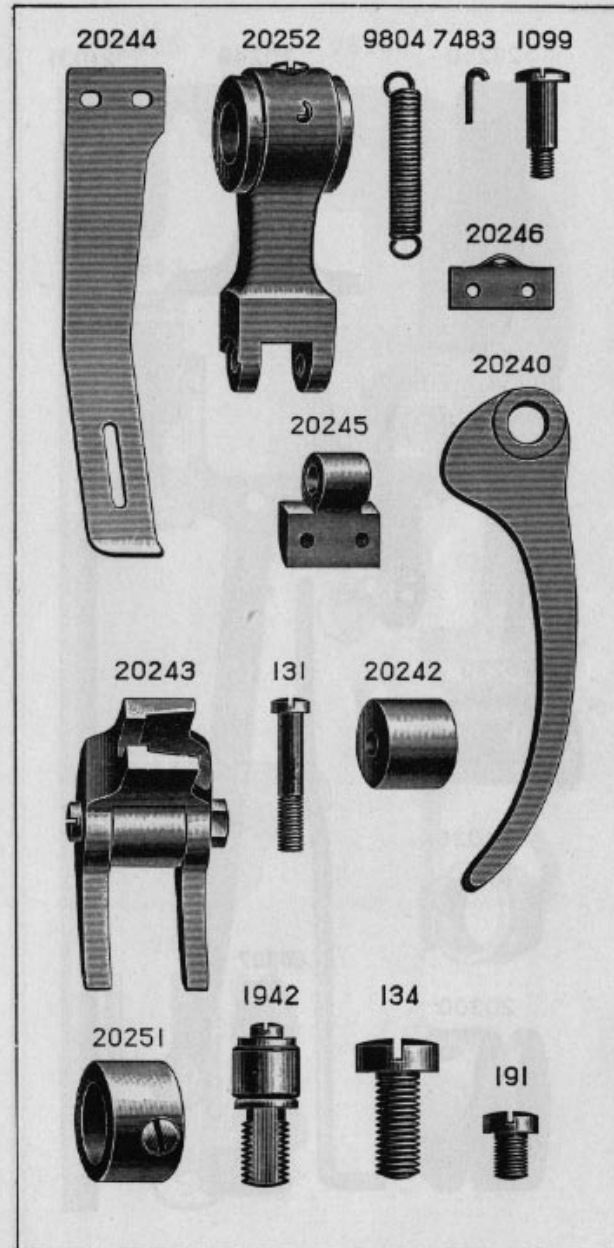




PLATE 2020—ONE-HALF SIZE

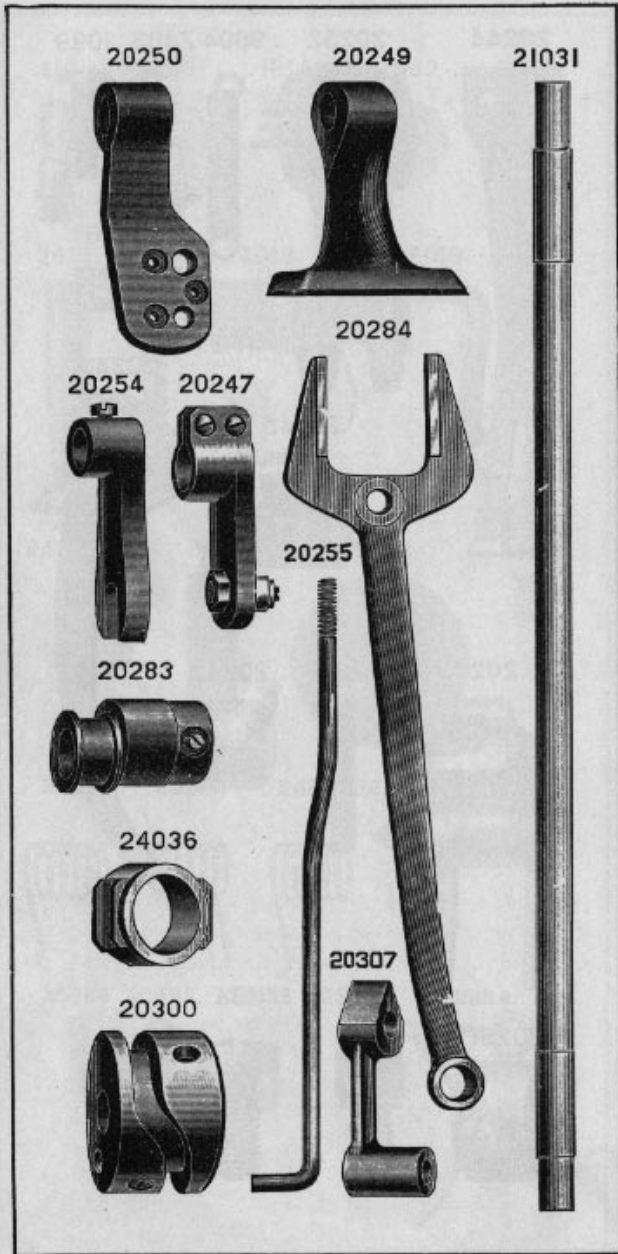


PLATE 2021—FULL SIZE

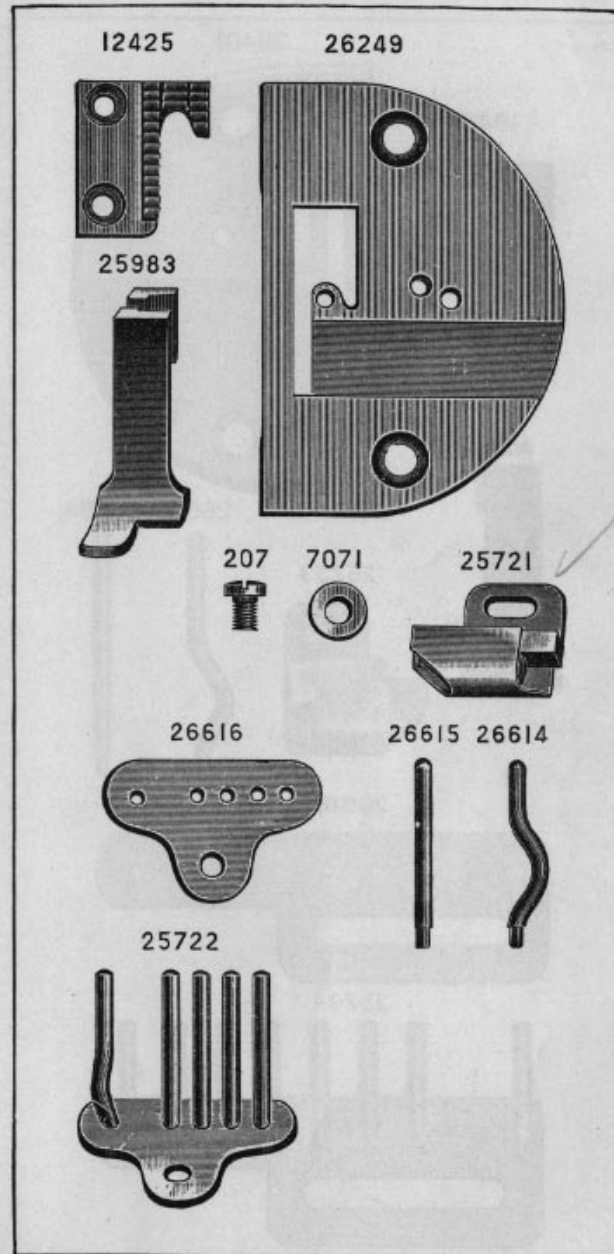
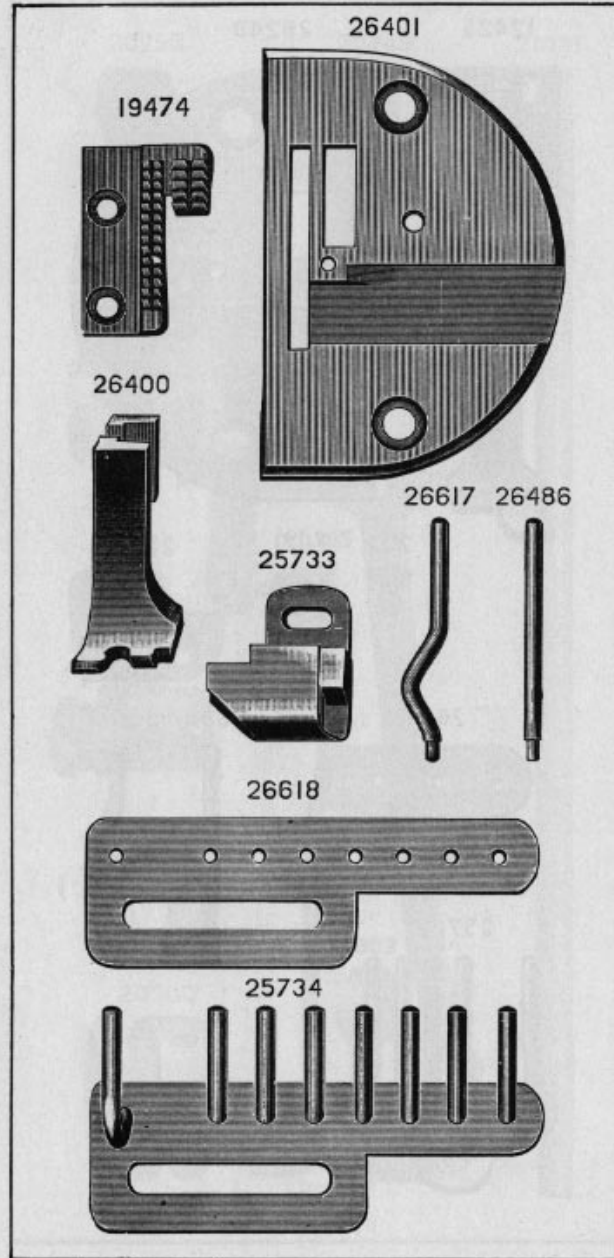


PLATE 2022—FULL SIZE



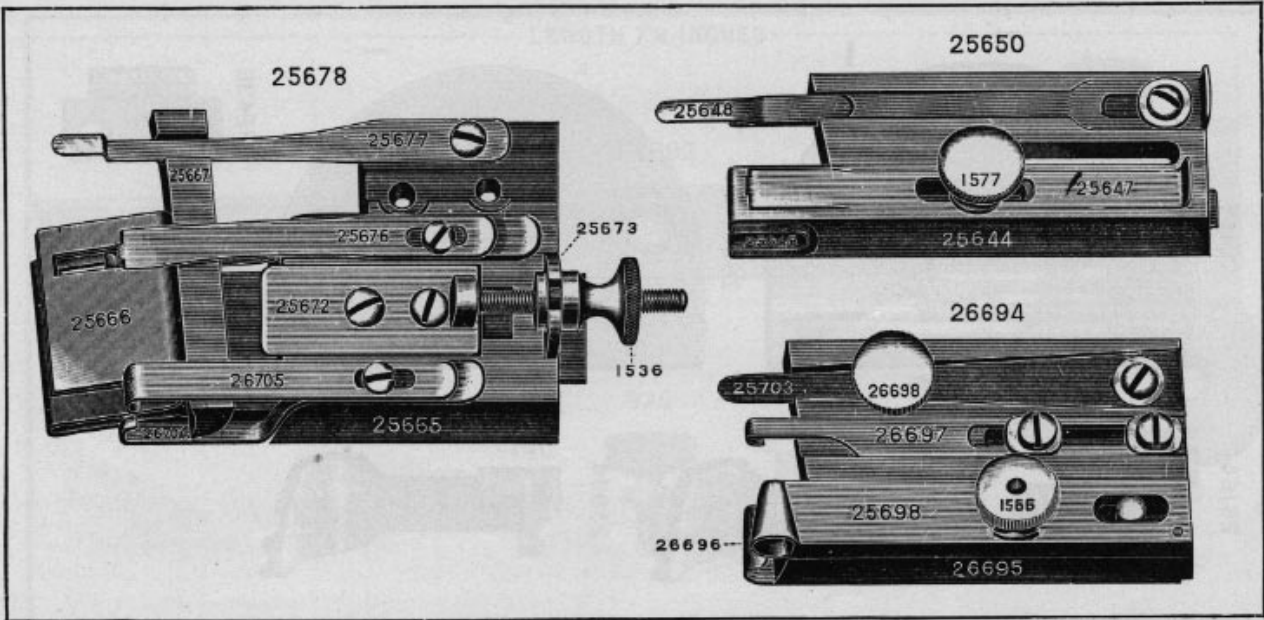
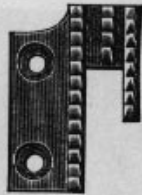


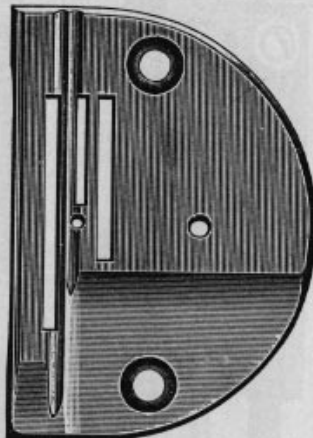
PLATE 2024—FULL SIZE

PLATE 2025—FULL SIZE

26166



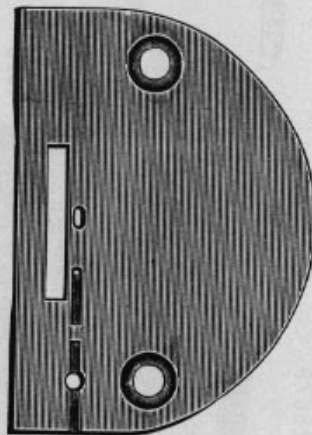
26168



26167



26381



25984



12436



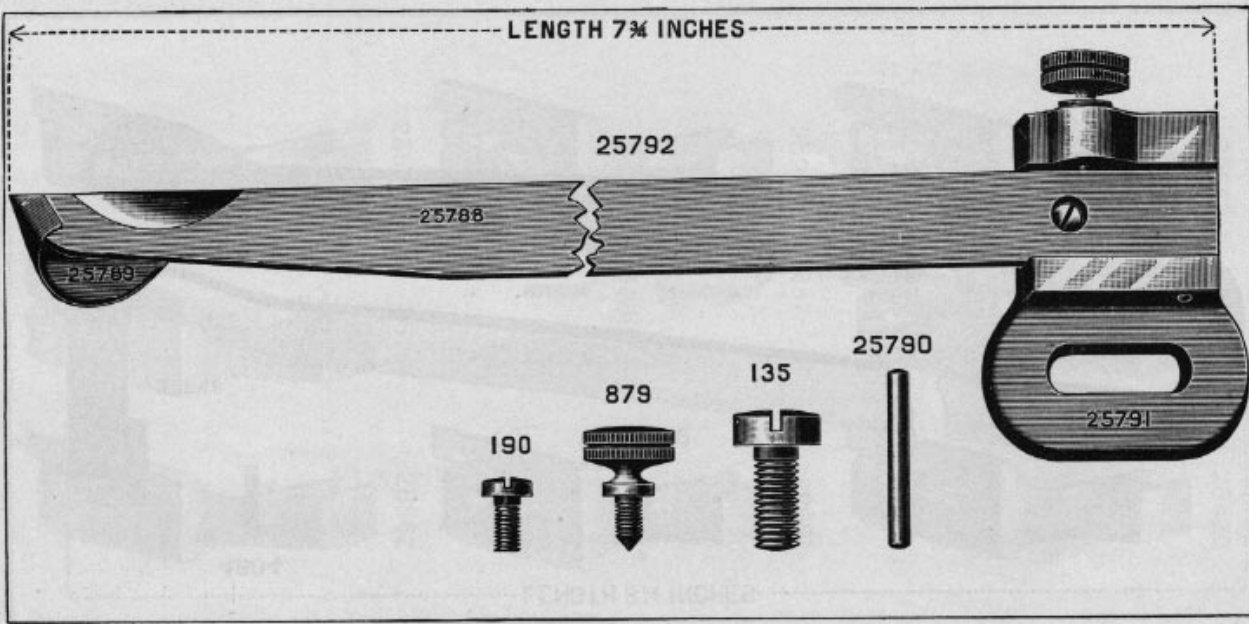


PLATE 2026—FULL SIZE

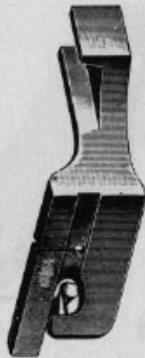


PLATE 2028—FULL SIZE

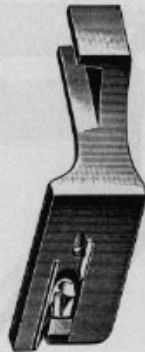
25922



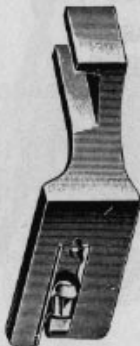
26161



26428



25920



6267



25888



28661



28663



28741



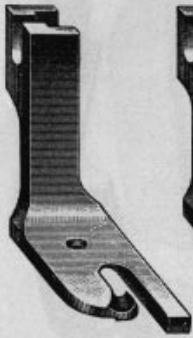
28662



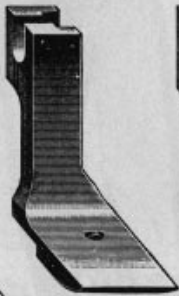


PLATE 2029—FULL SIZE

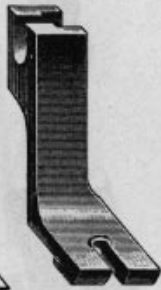
26403



25985



26638



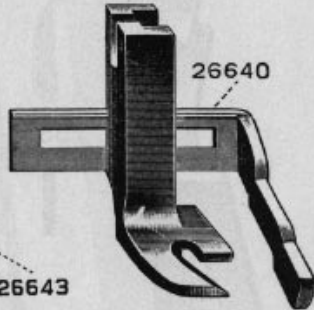
26650



26646



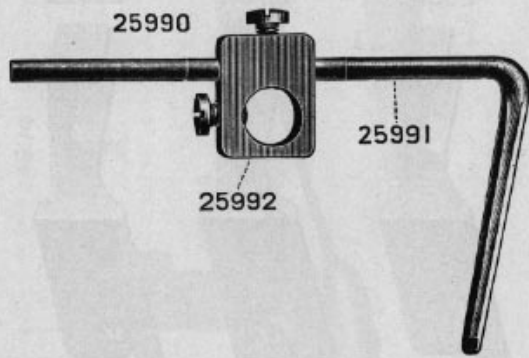
26641



26640

26643

25990

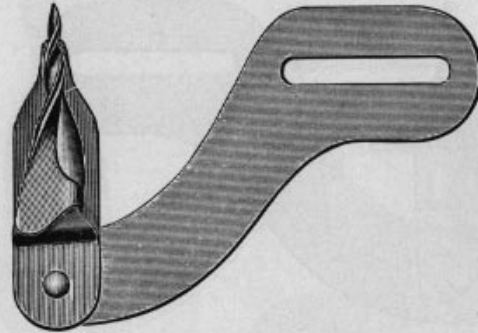


25991

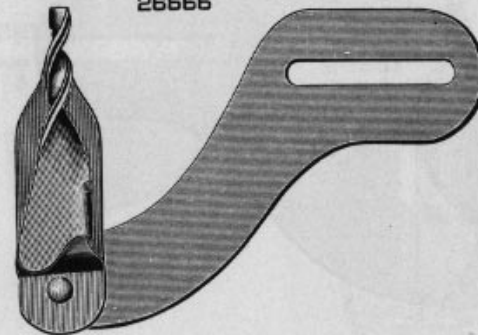
25992

PLATE 2030—FULL SIZE

26664



26666



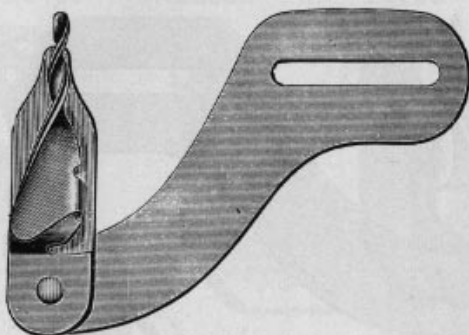
26658



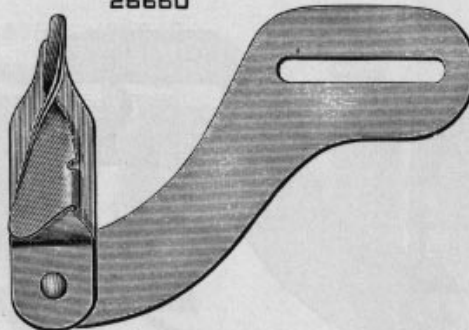


PLATE 2031—FULL SIZE

26655



26660



26662

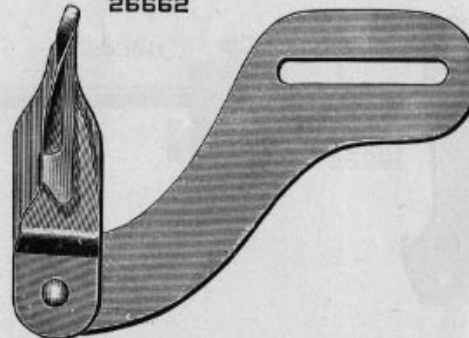
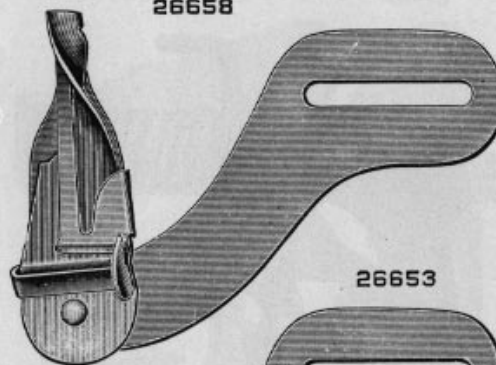
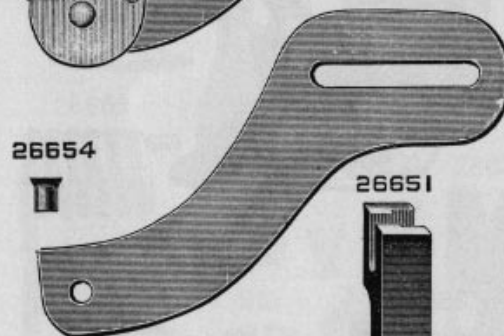


PLATE 2032—FULL SIZE

26658



26653



26654



26651

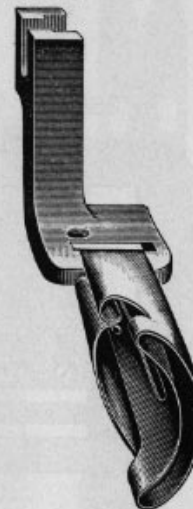


PLATE 2034—FULL SIZE

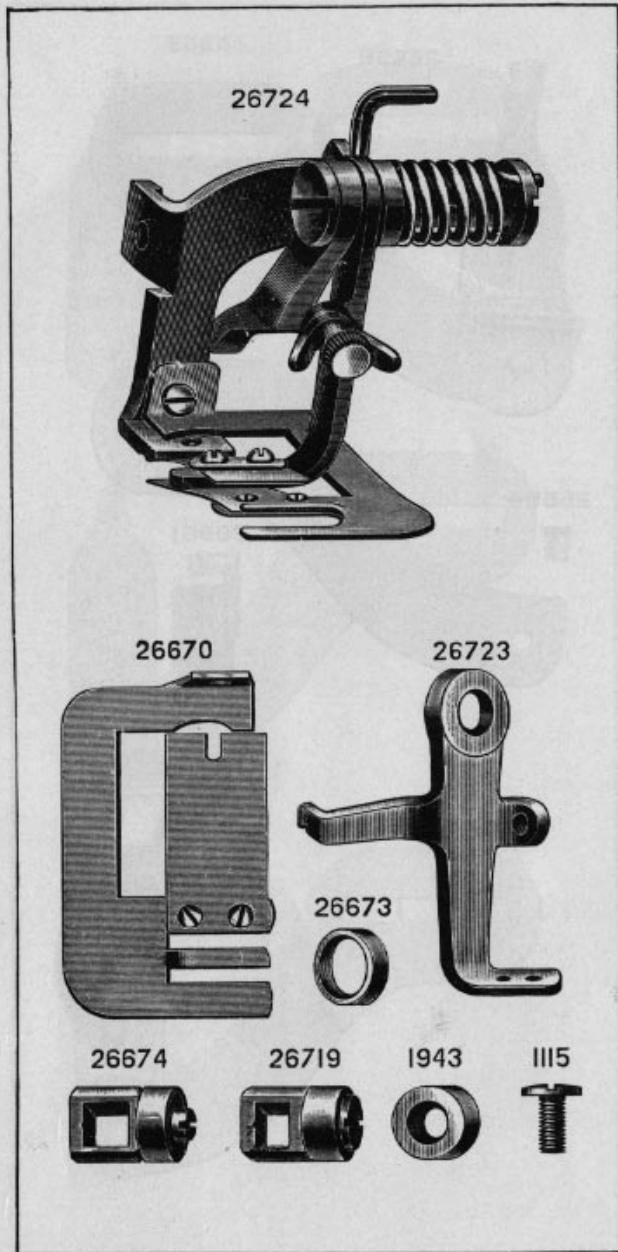
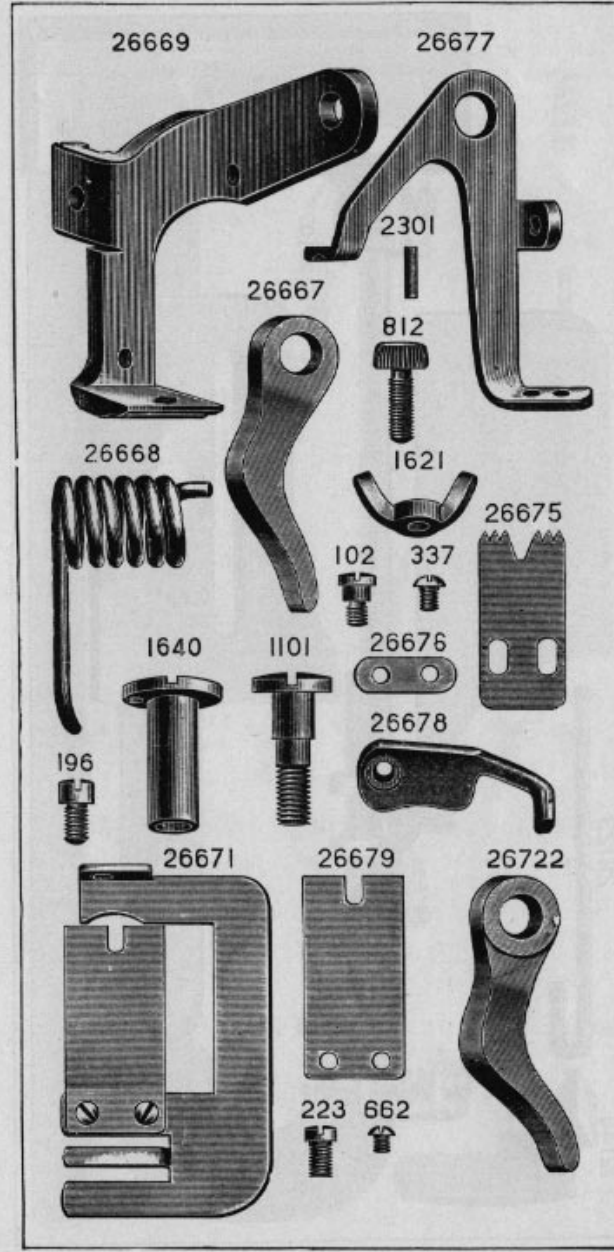


PLATE 2035—FULL SIZE



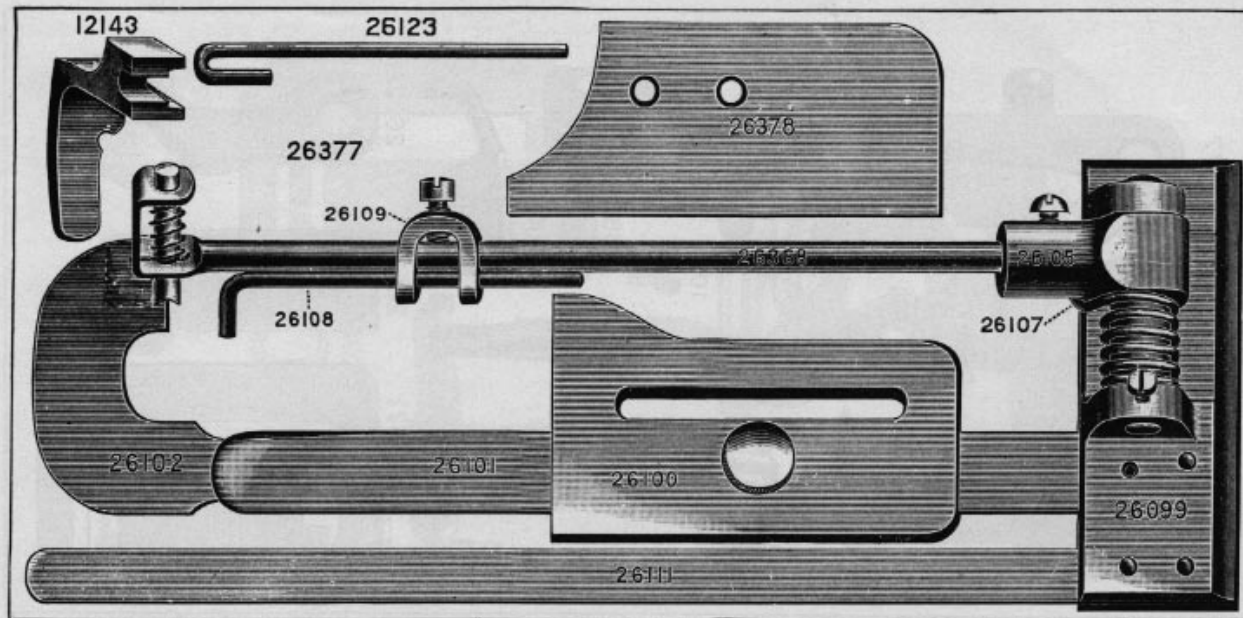


PLATE 2037—FULL SIZE

PLATE 2038—FULL SIZE

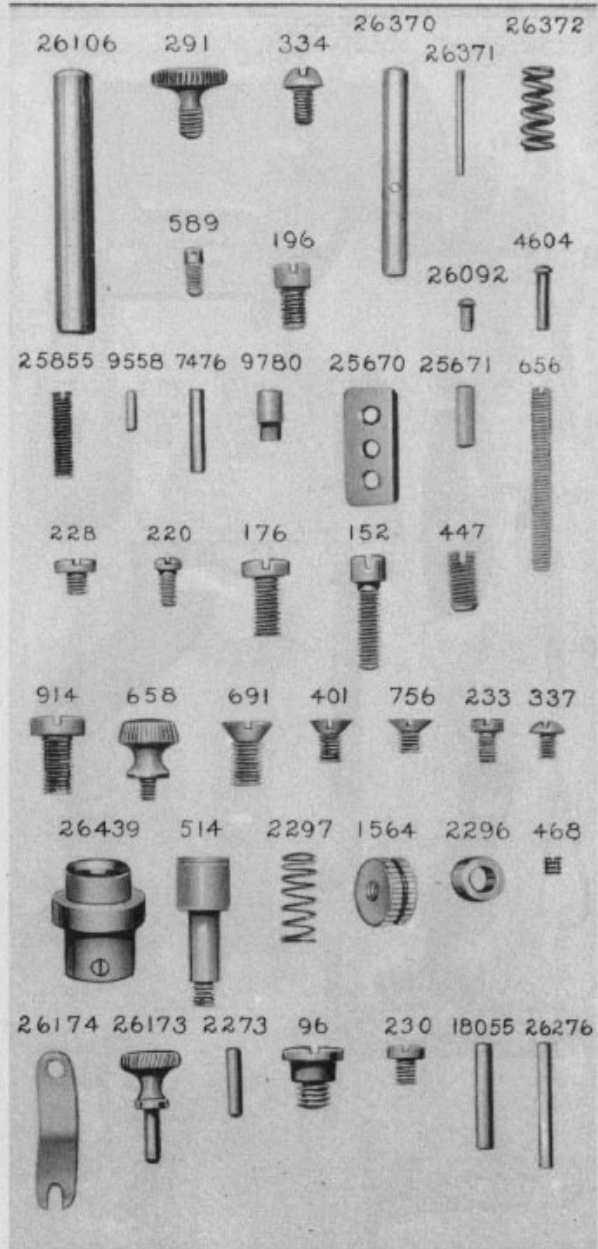


PLATE 2039—FULL SIZE

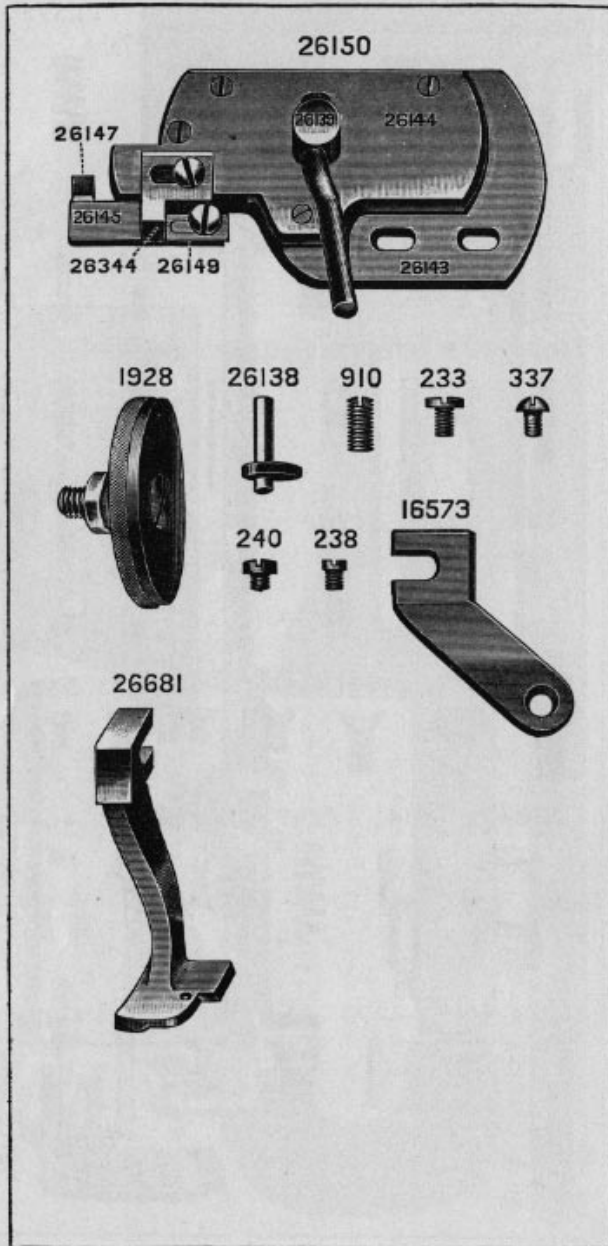


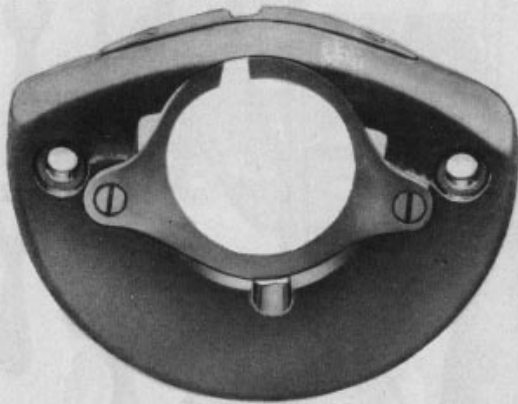
PLATE 2045—ONE-HALF SIZE





PLATE 2046—FULL SIZE

24325



24323



24009

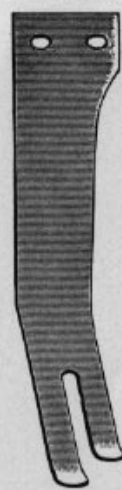


19406



PLATE 2048—FULL SIZE

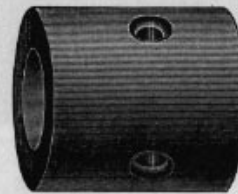
20347



20322



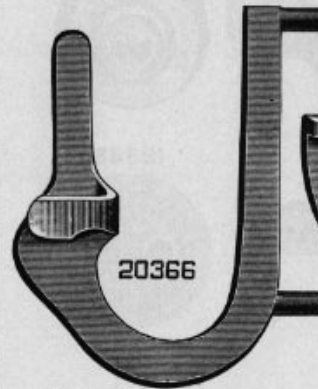
20321



20324



20366



20370

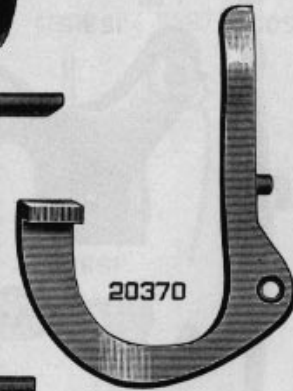


PLATE 2049—ONE-FOURTH SIZE

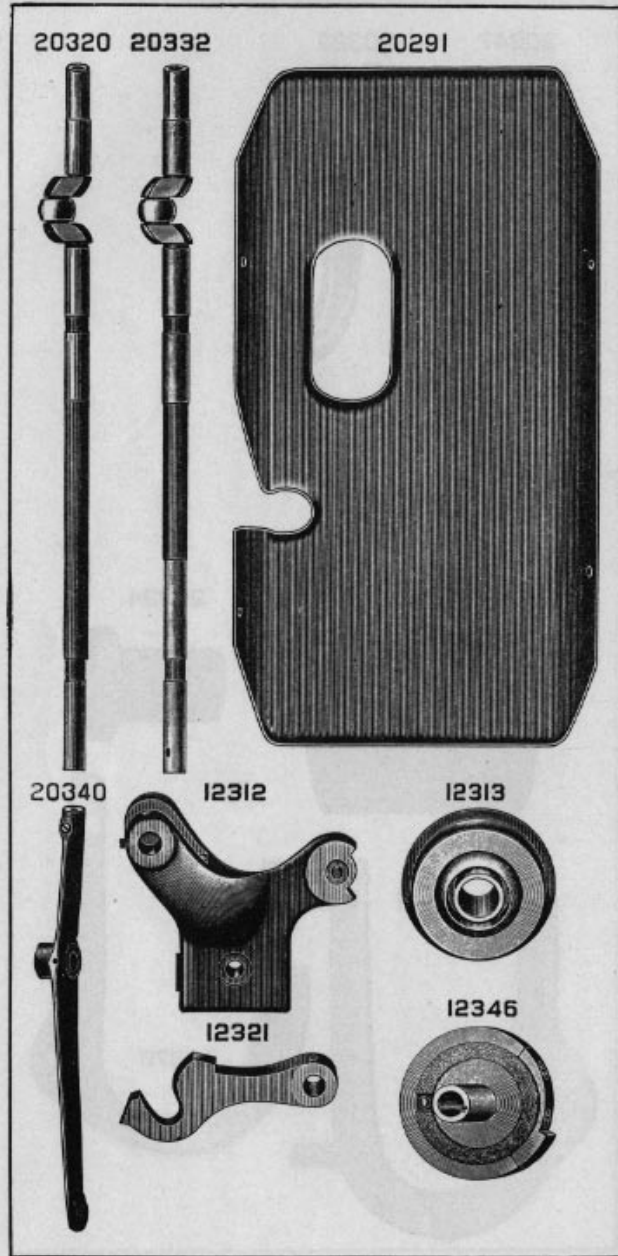
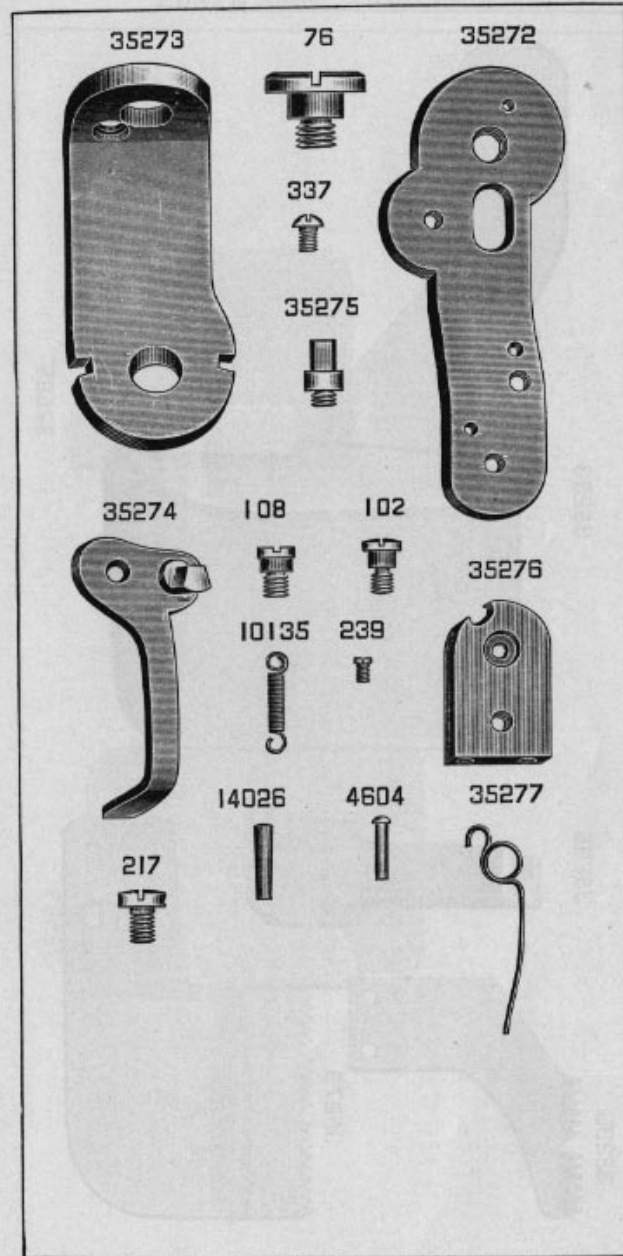


PLATE 2061—FULL SIZE



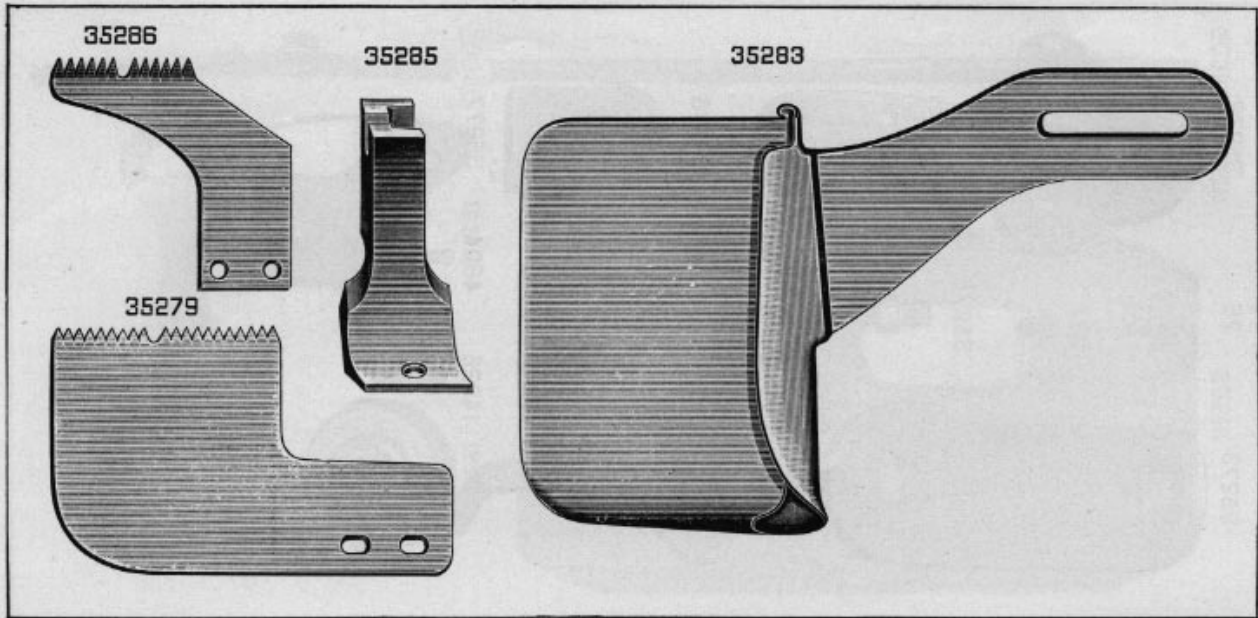


PLATE 2062—FULL SIZE

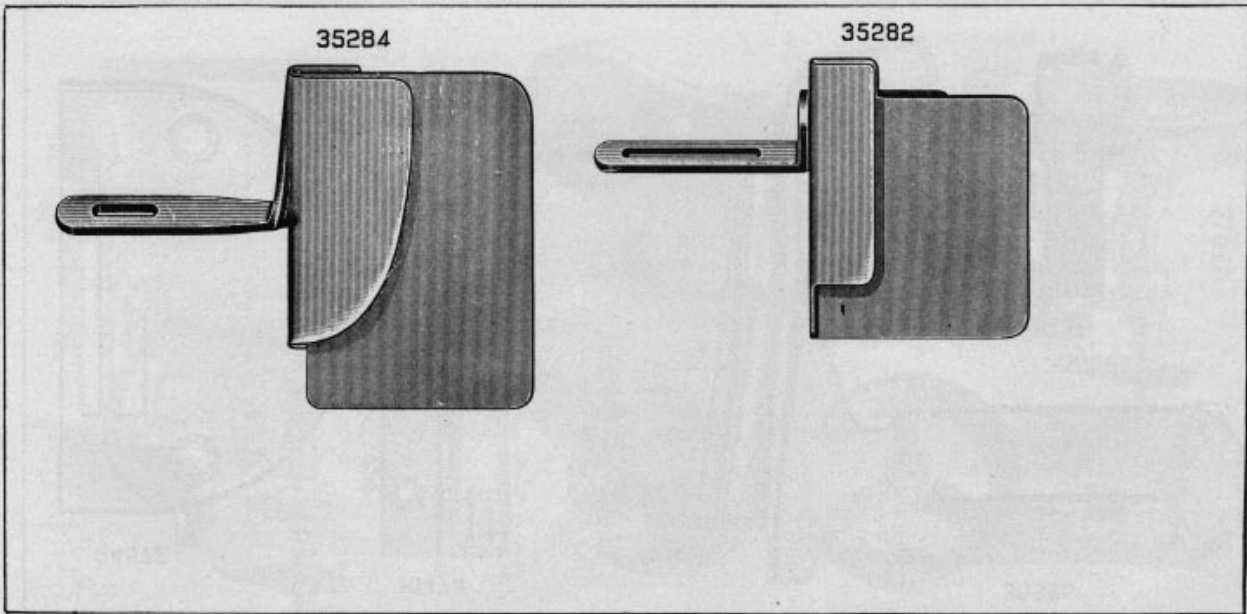


PLATE 2064—FULL SIZE



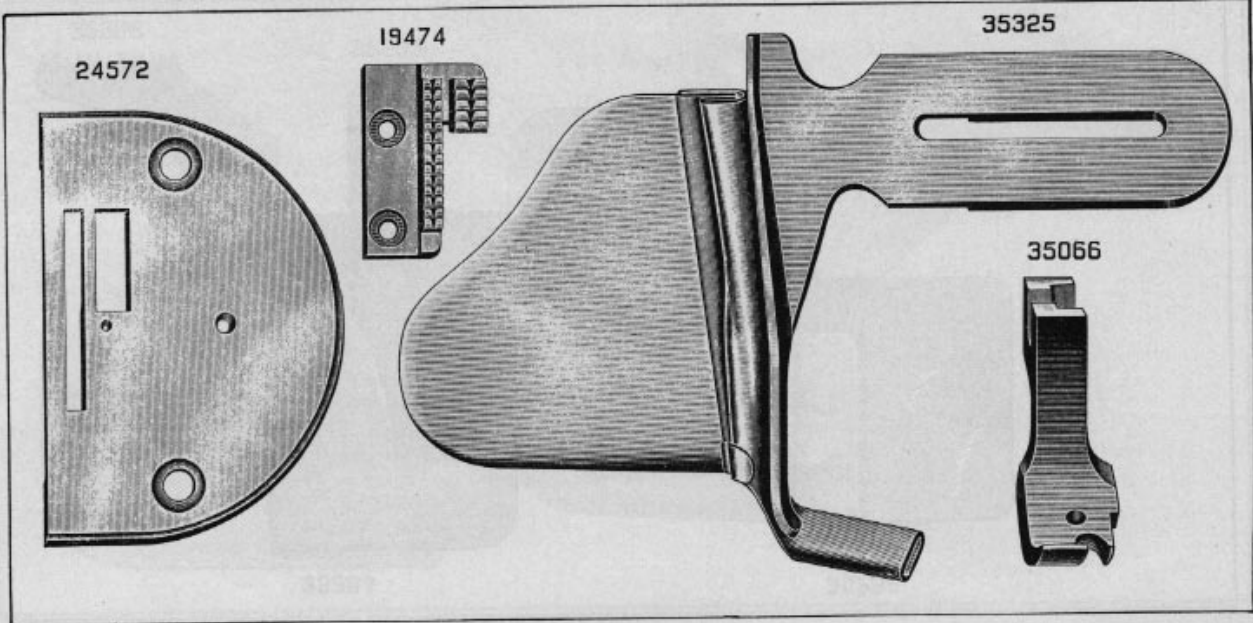


PLATE 2067—FULL SIZE

PLATE 2445—ONE-HALF SIZE

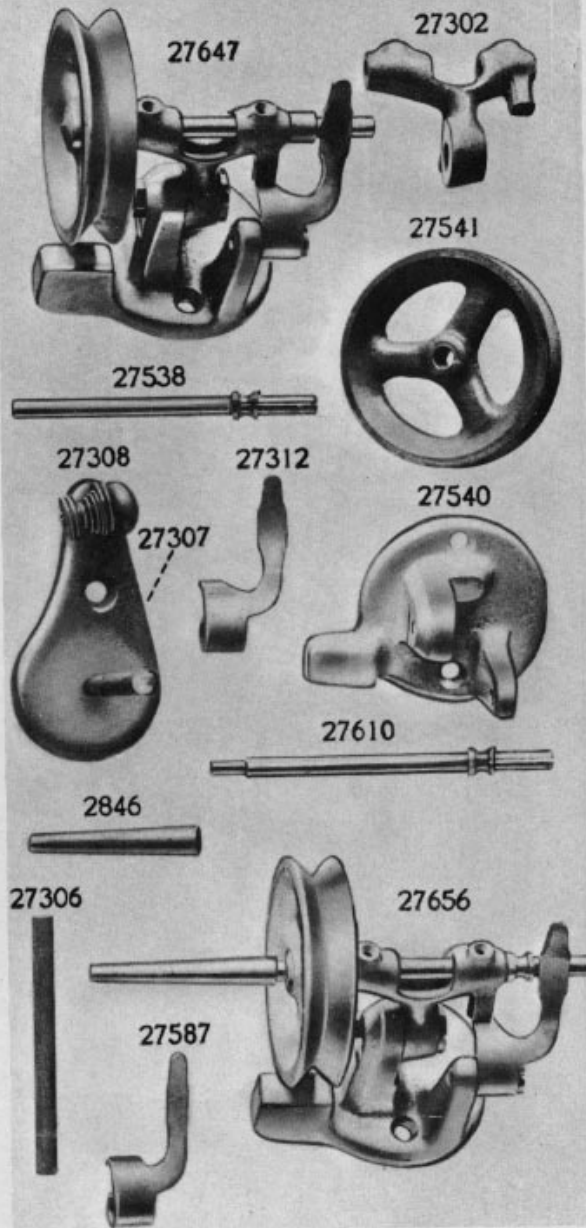


PLATE 2565 - FULL SIZE



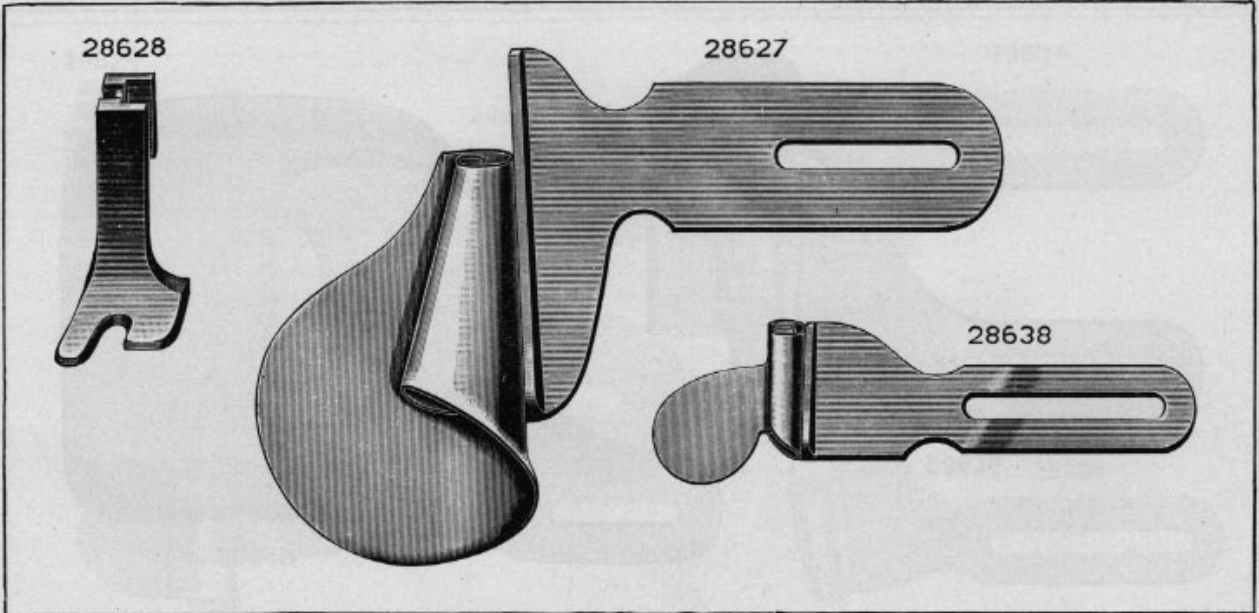


PLATE 2600—FULL SIZE

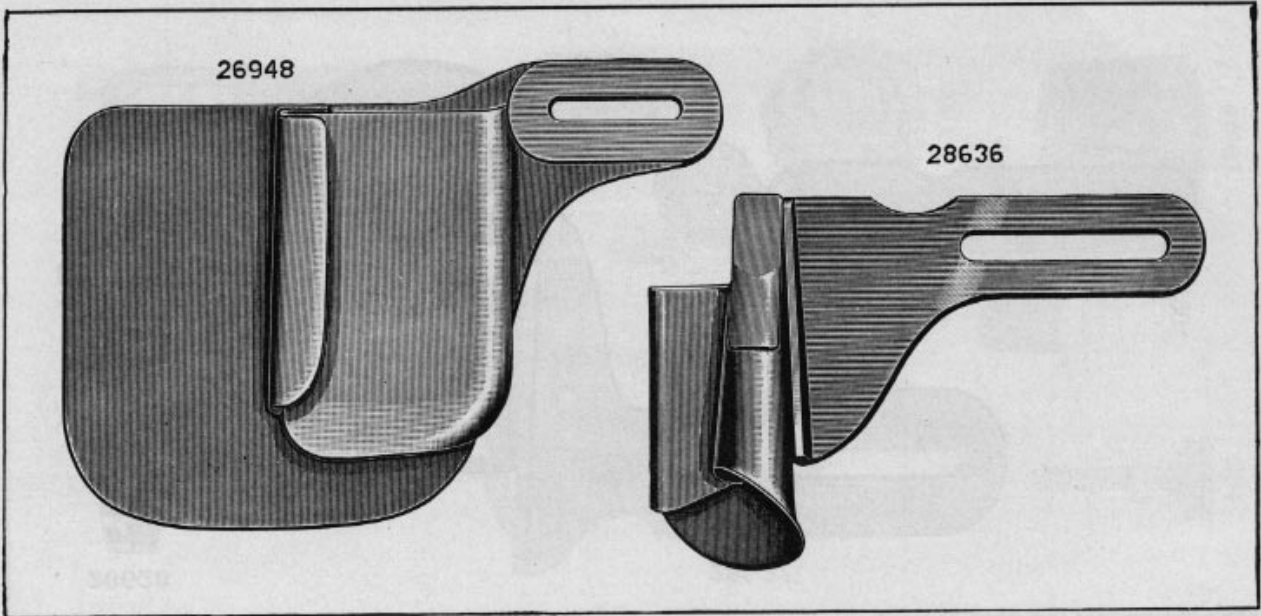


PLATE 2601—FULL SIZE

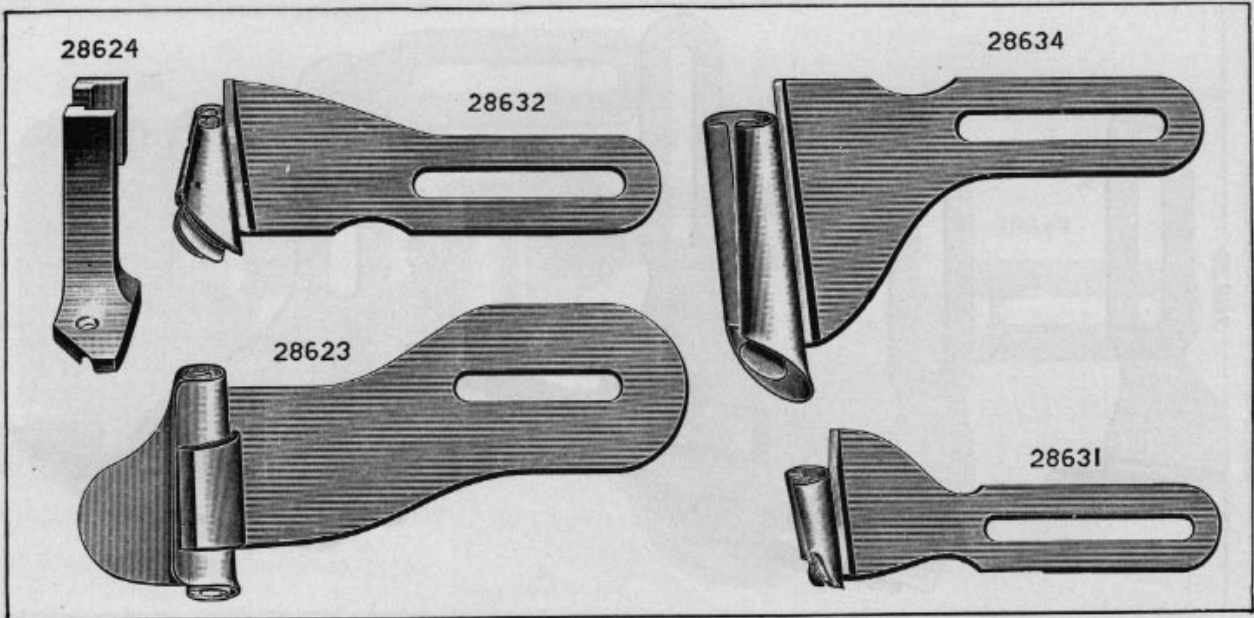


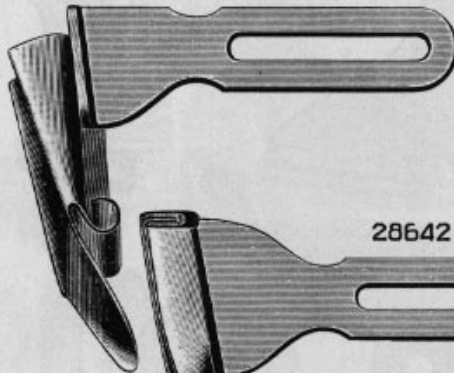
PLATE 2602—FULL SIZE

PLATE 2603—FULL SIZE

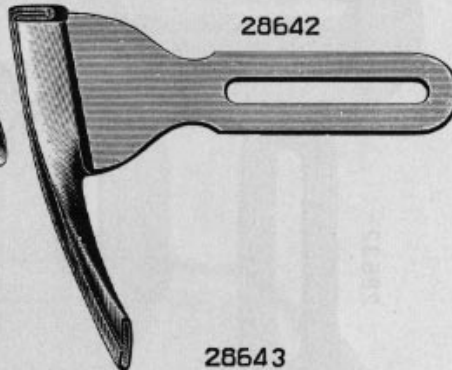
28639



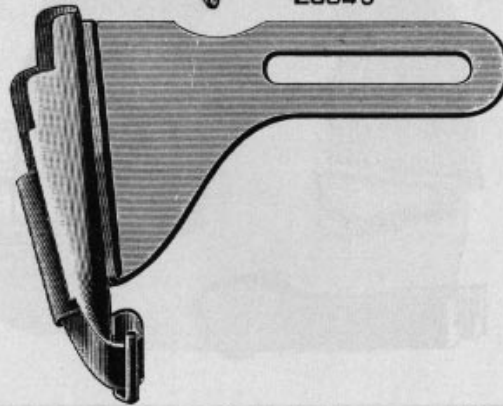
28641



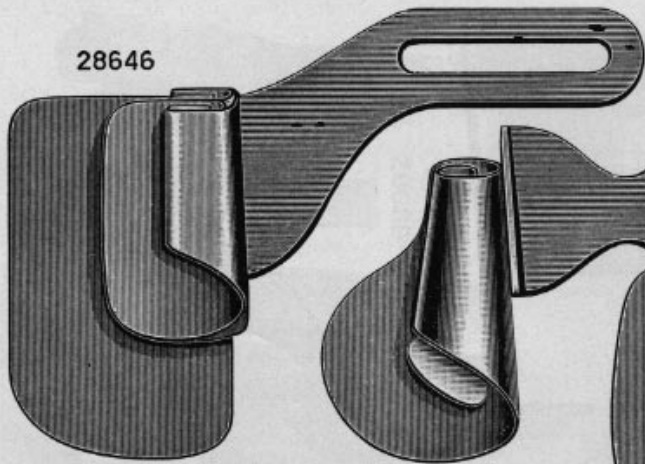
28642



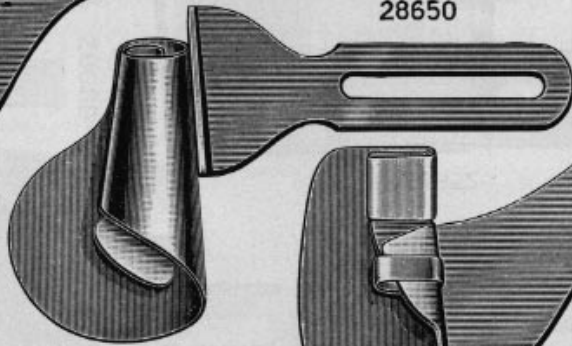
28643



28646



28650



28649

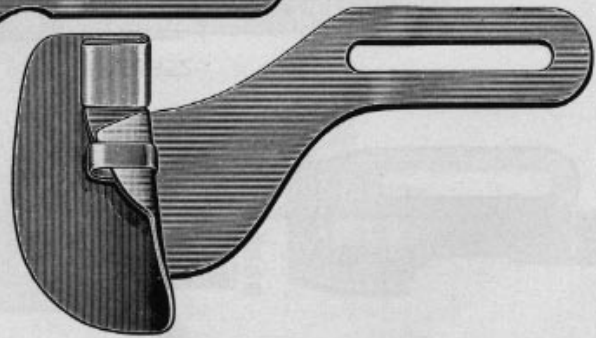
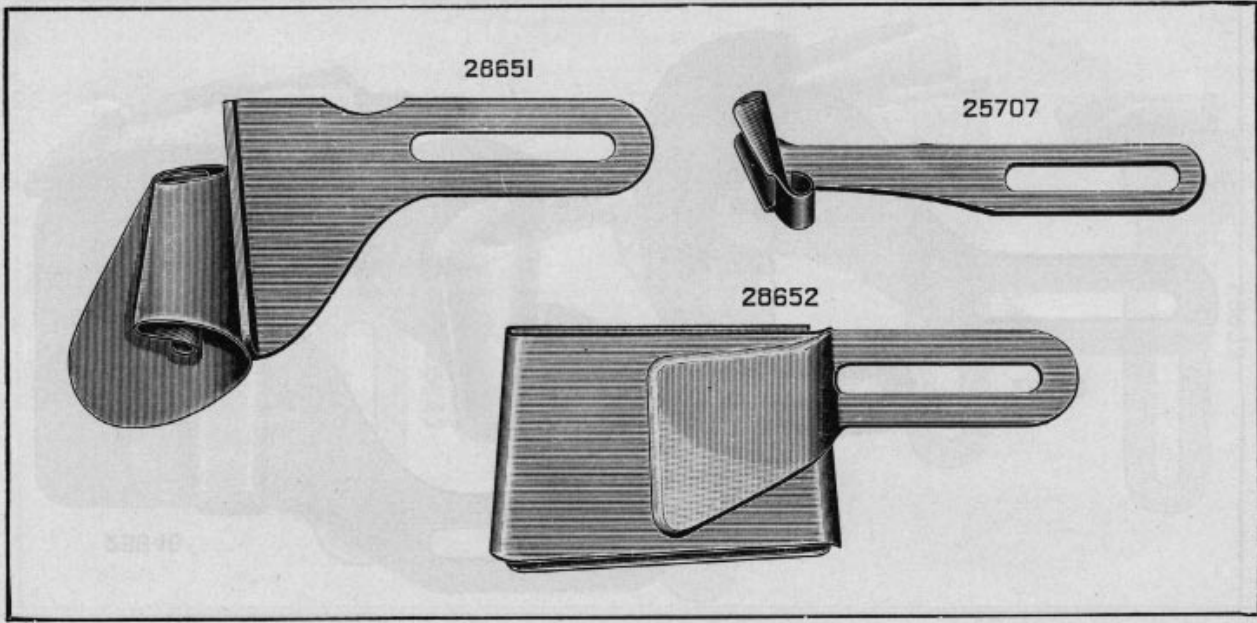


PLATE 2604—FULL SIZE





28651

25707

28652

PLATE 2605—FULL SIZE



PLATE 2606—FULL SIZE

28666



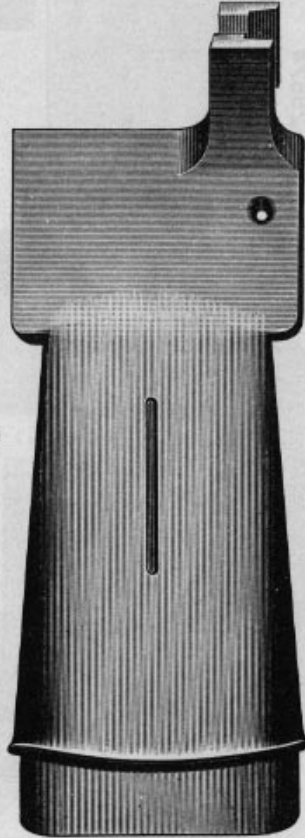
28667



28665



28668



28670



28669



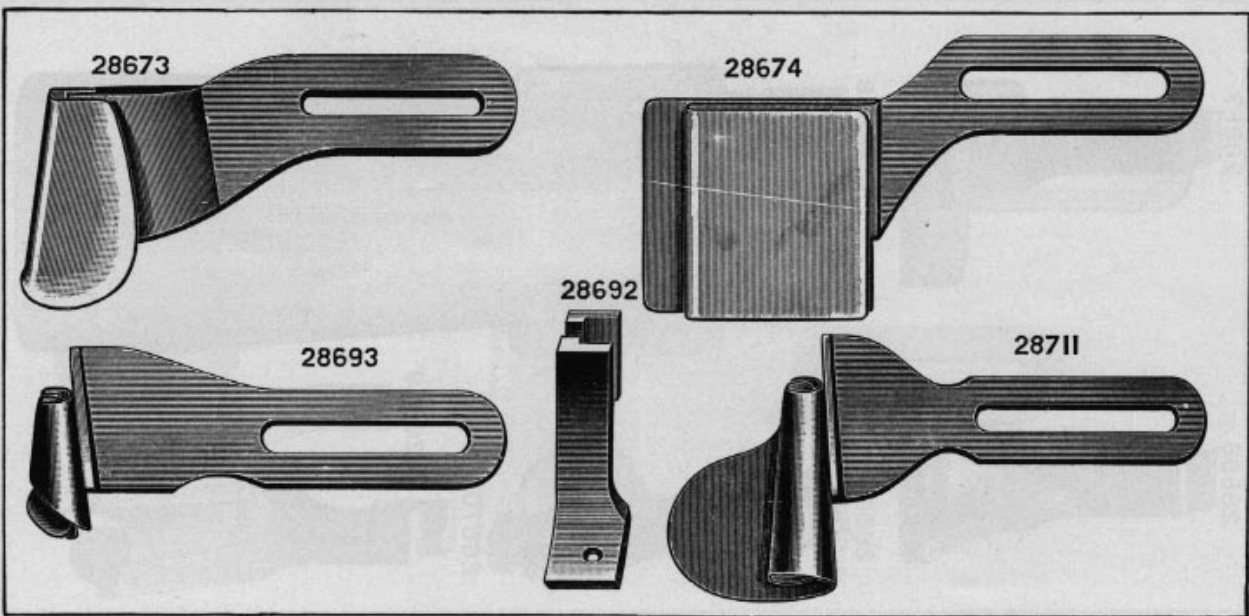
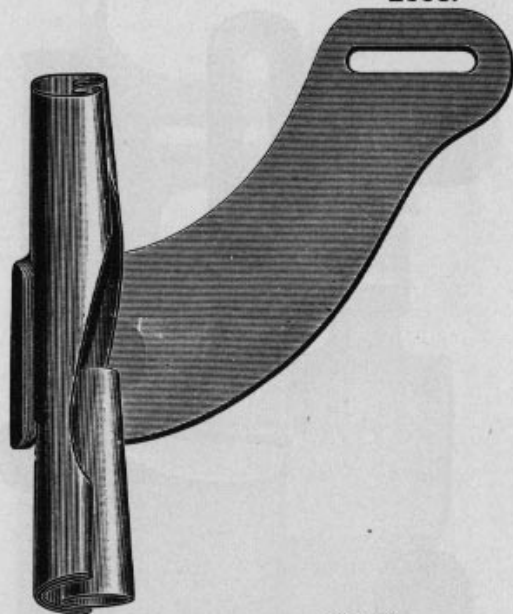


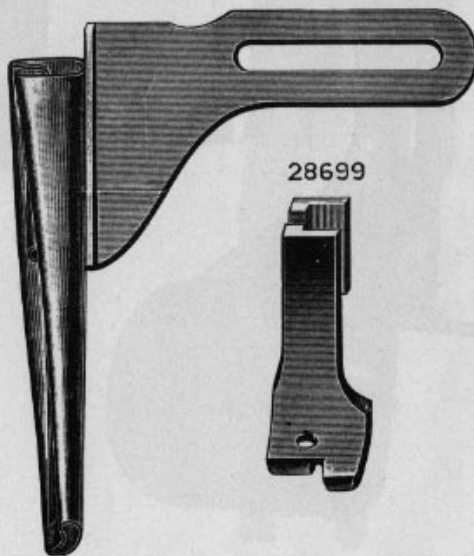
PLATE 2607—FULL SIZE

PLATE 2608—FULL SIZE

28697



28698



28699



PLATE 2609—FULL SIZE

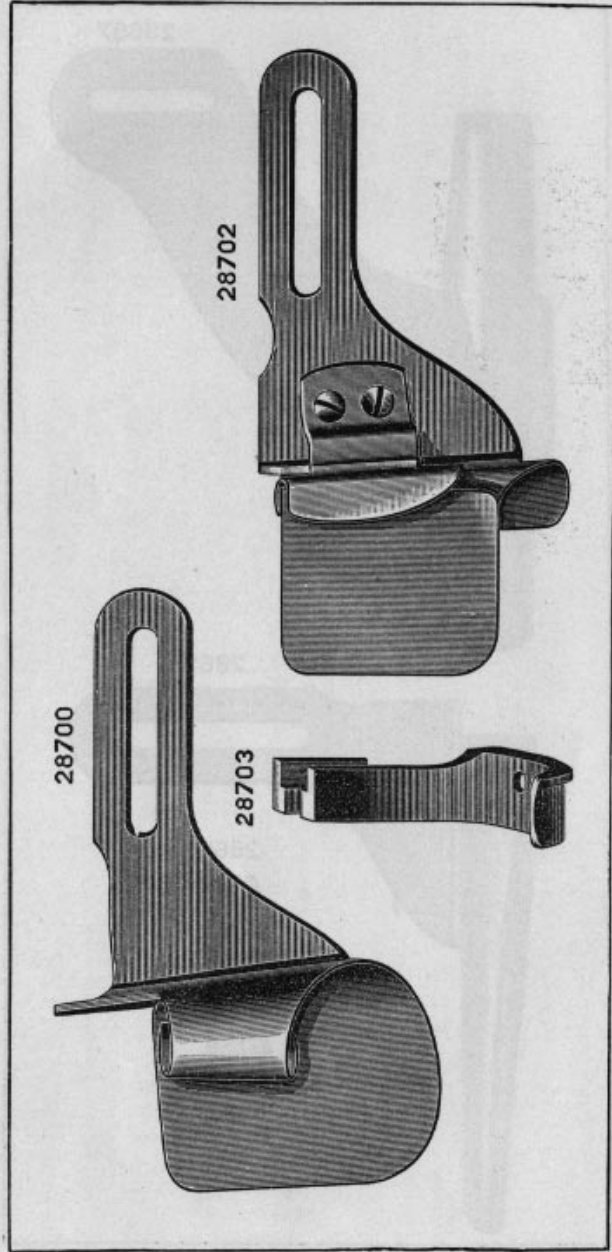


PLATE 2610—FULL SIZE

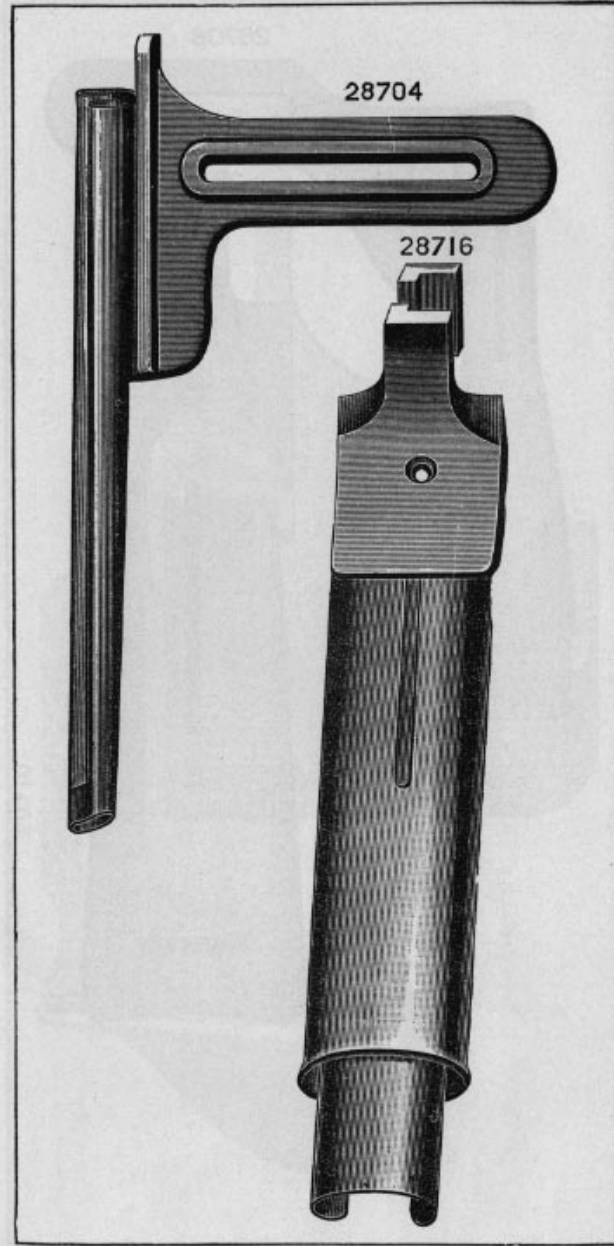
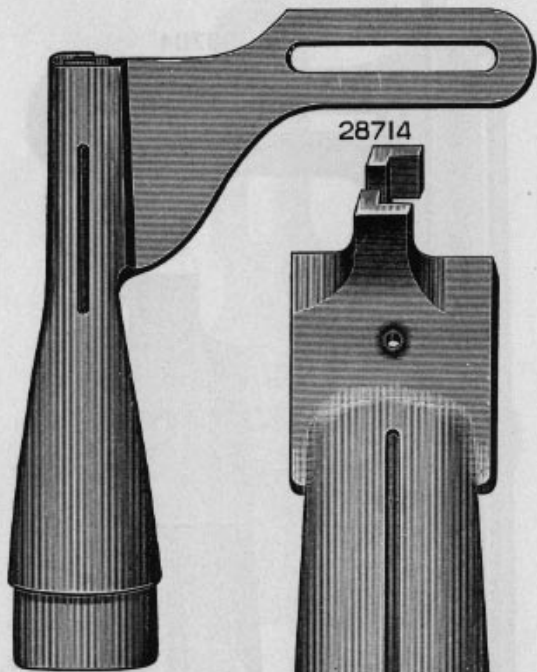
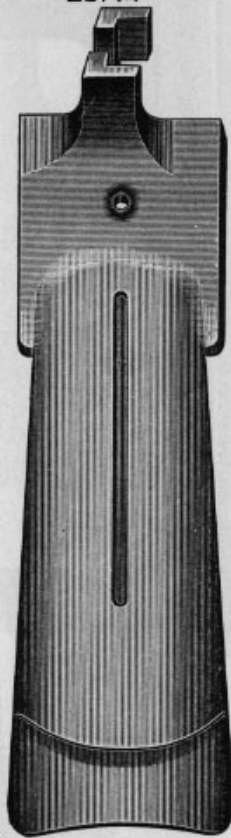


PLATE 2611—FULL SIZE

28708



28714



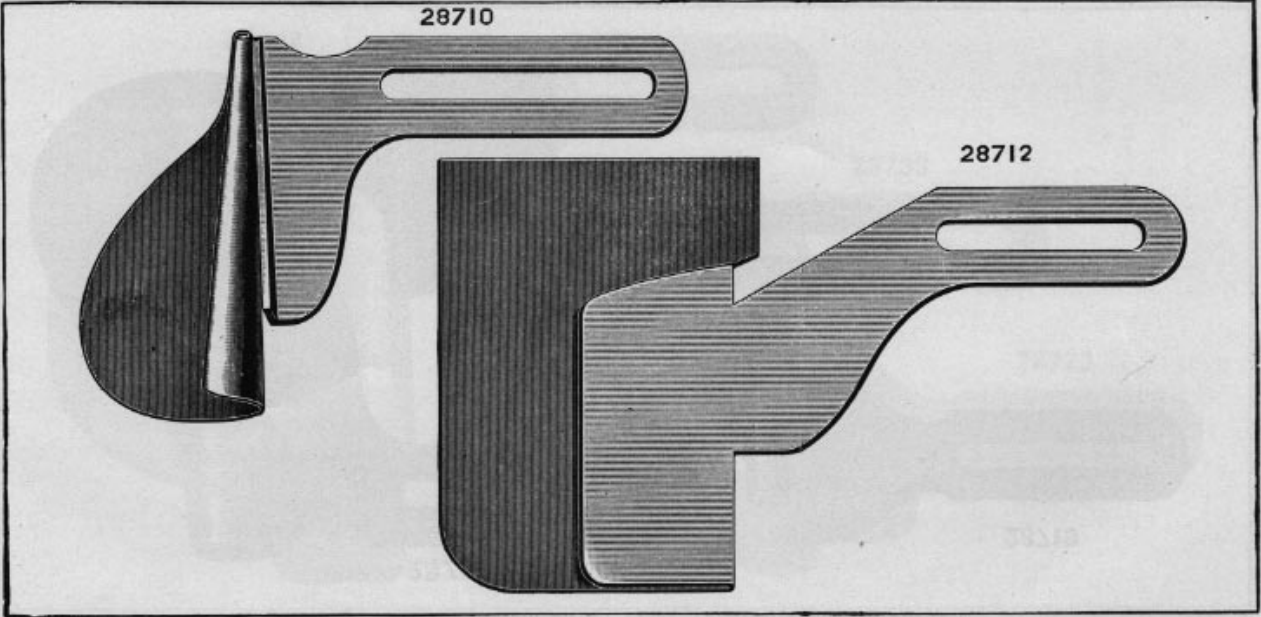


PLATE 2612—FULL SIZE



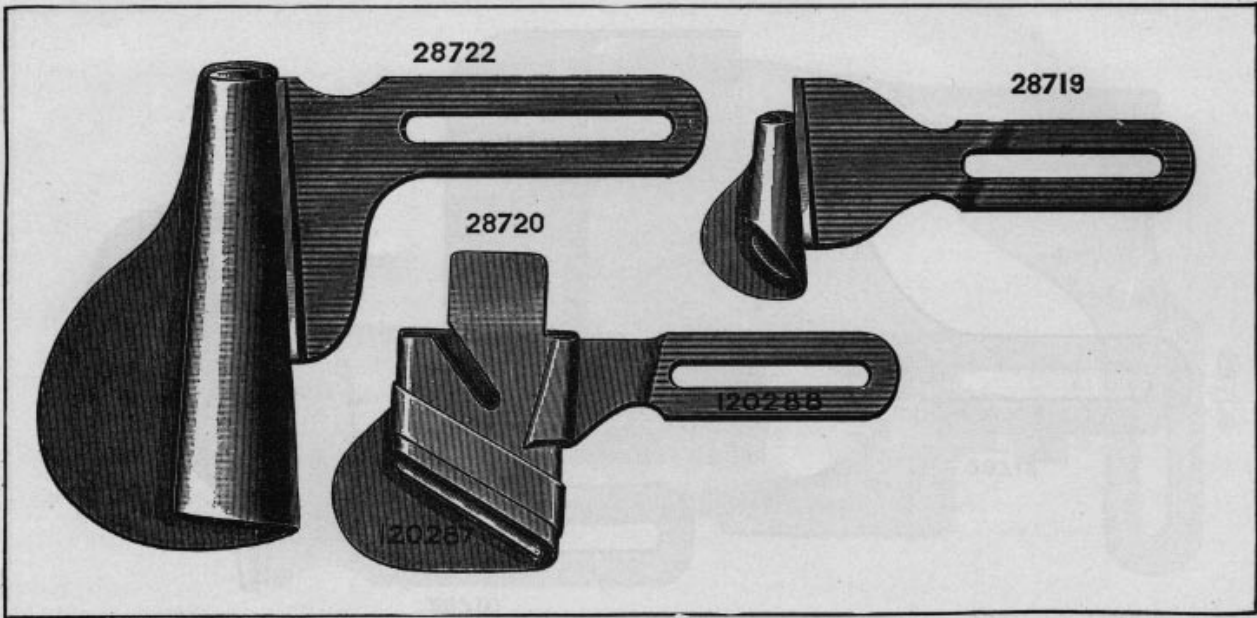


PLATE 2613—FULL SIZE

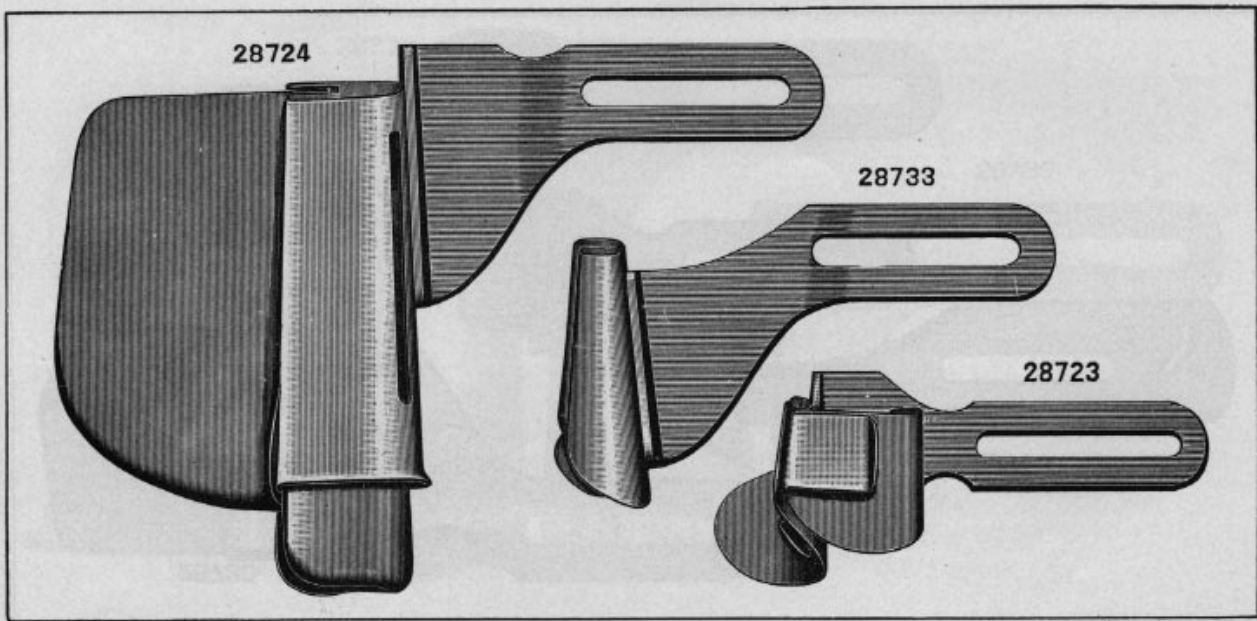


PLATE 2614—FULL SIZE

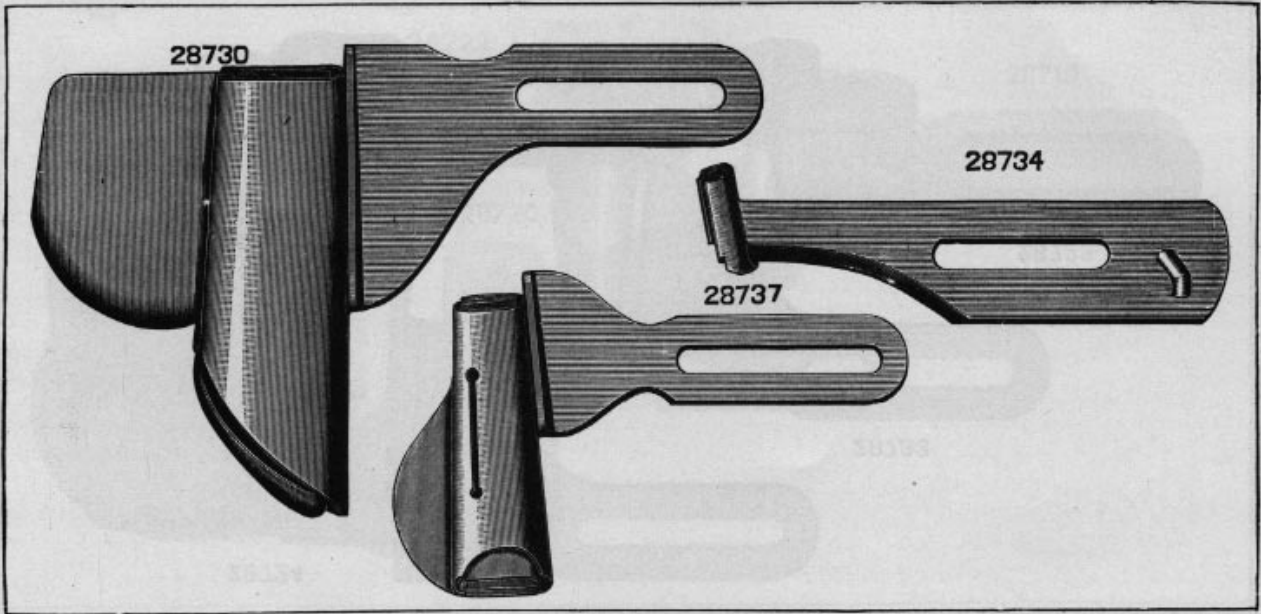


PLATE 2615—FULL SIZE

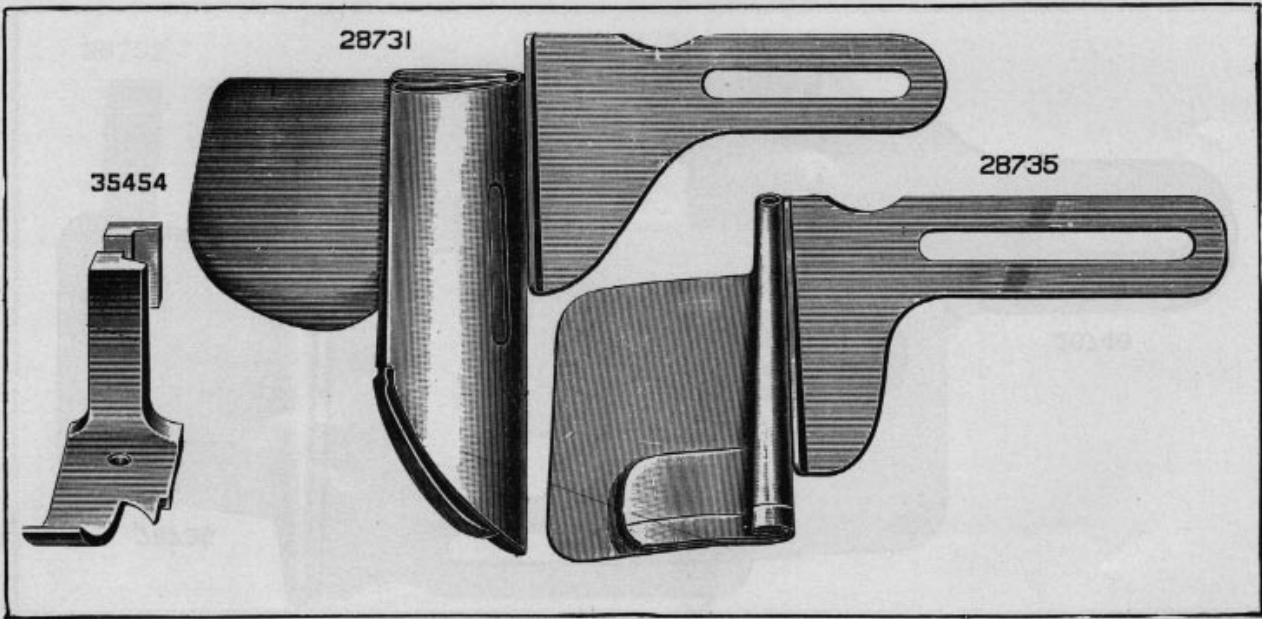
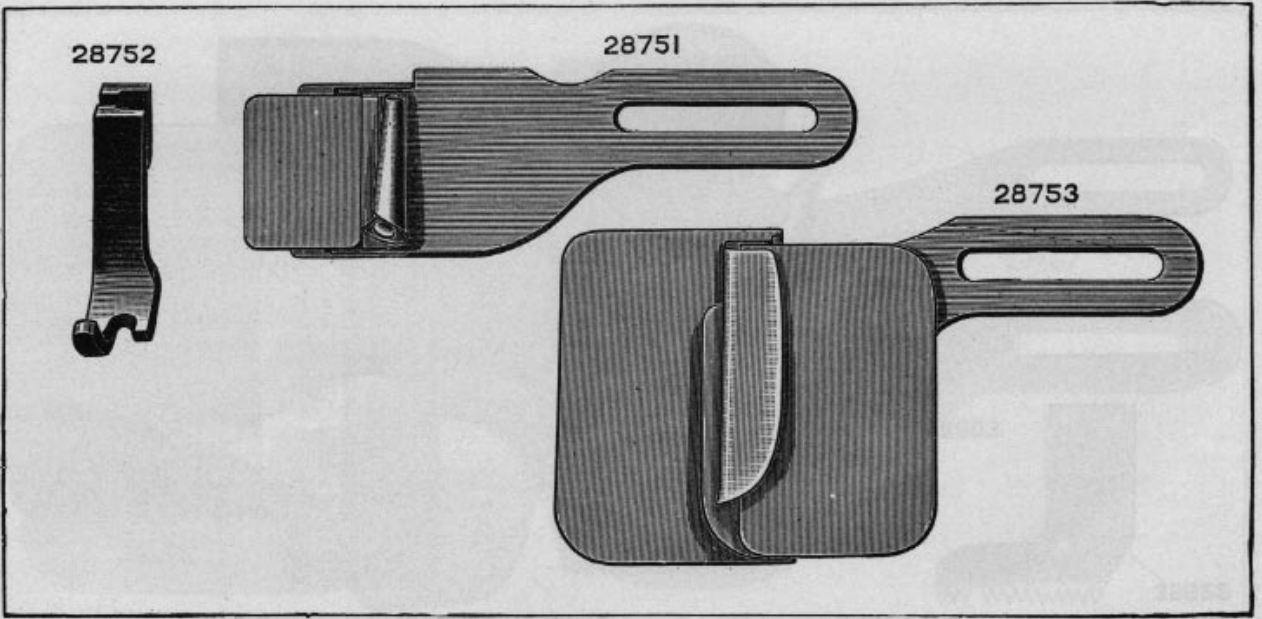
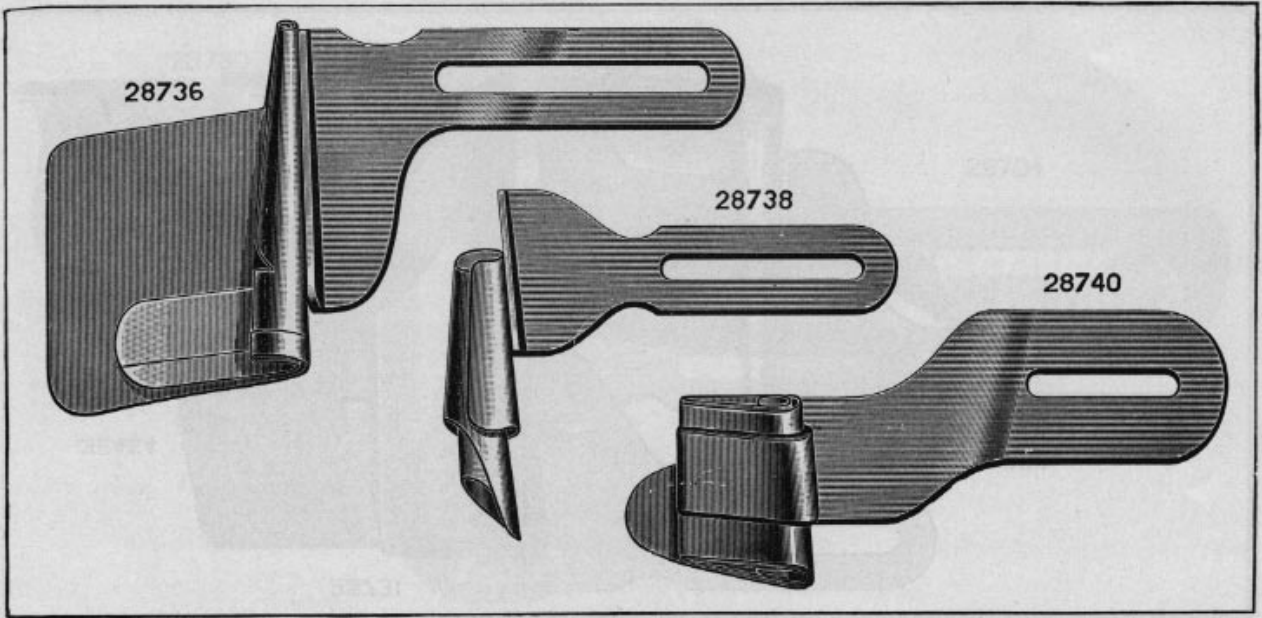
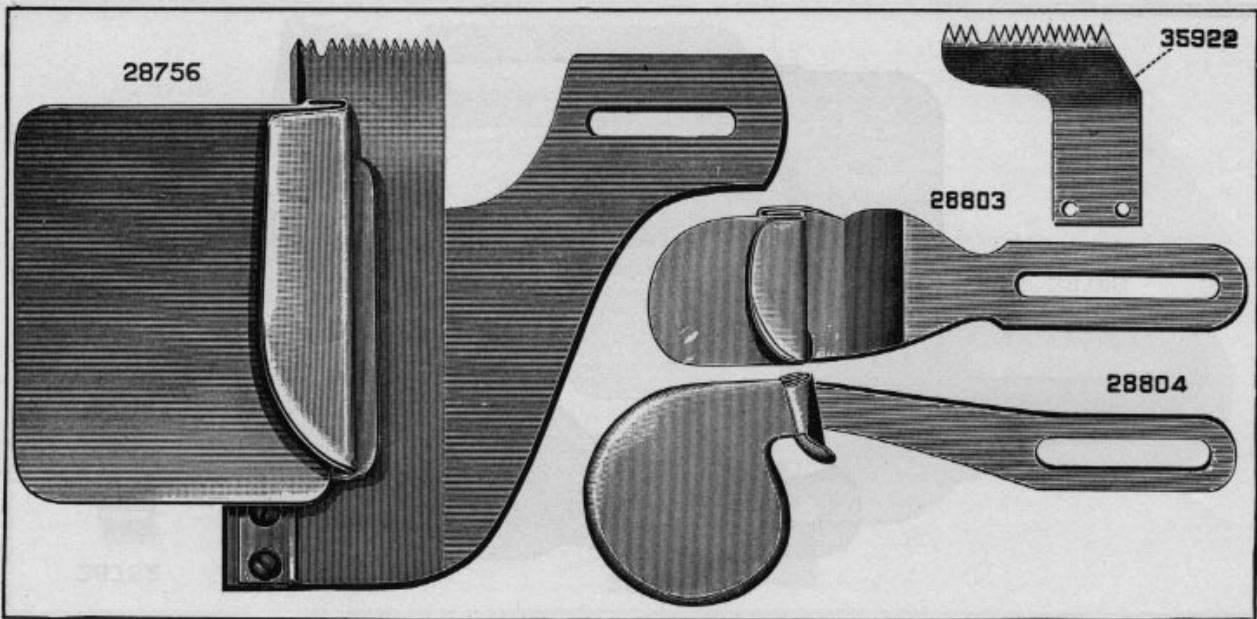


PLATE 2616—FULL SIZE







28756

35922

28803

28804

PLATE 2619—FULL SIZE

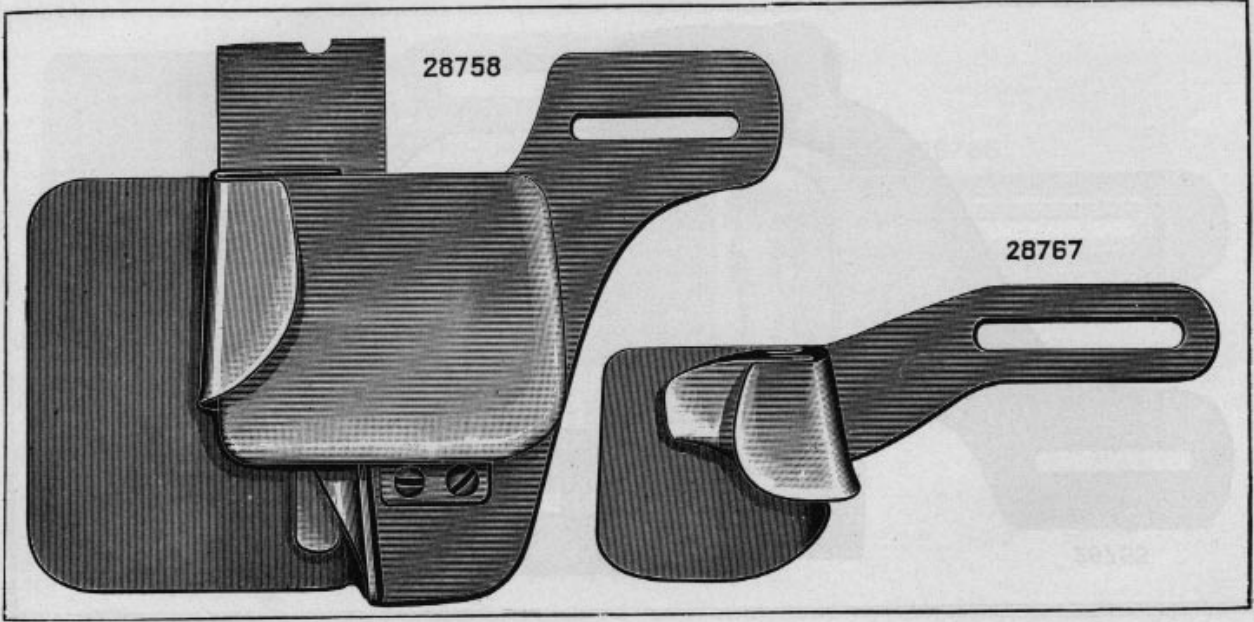
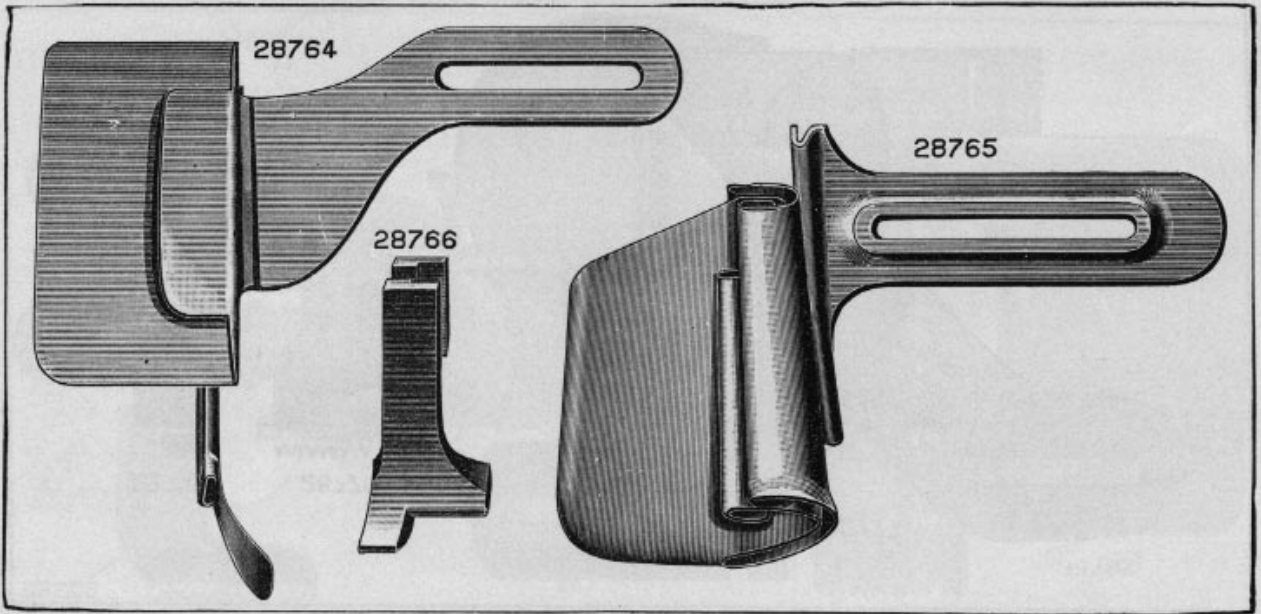
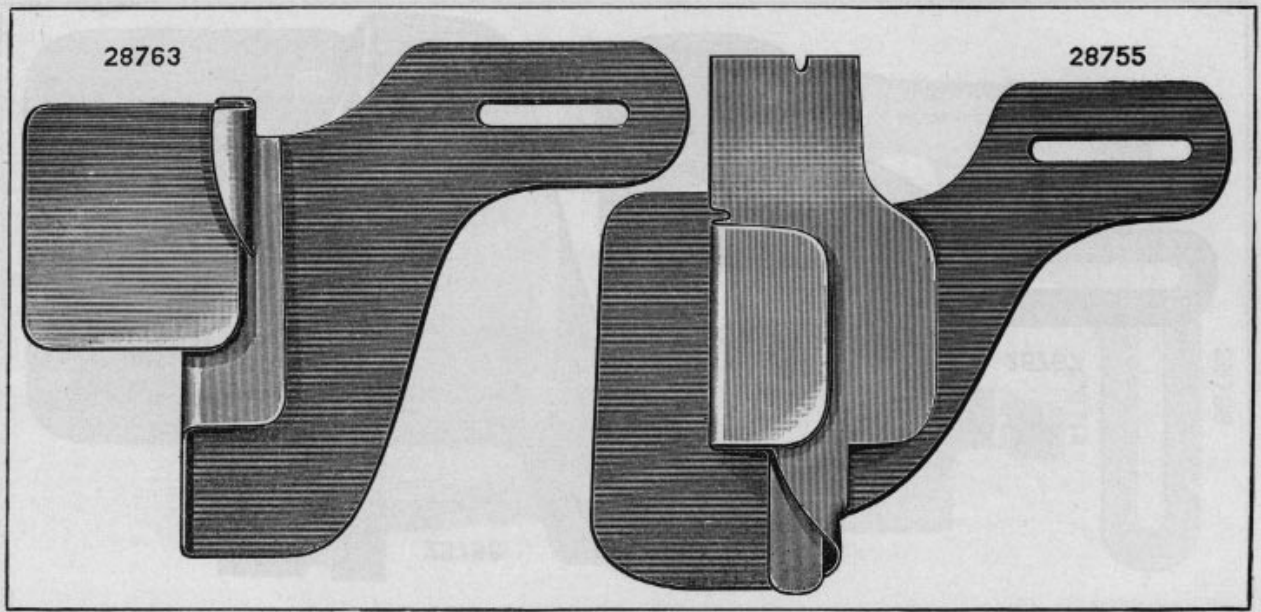


PLATE 2620—FULL SIZE



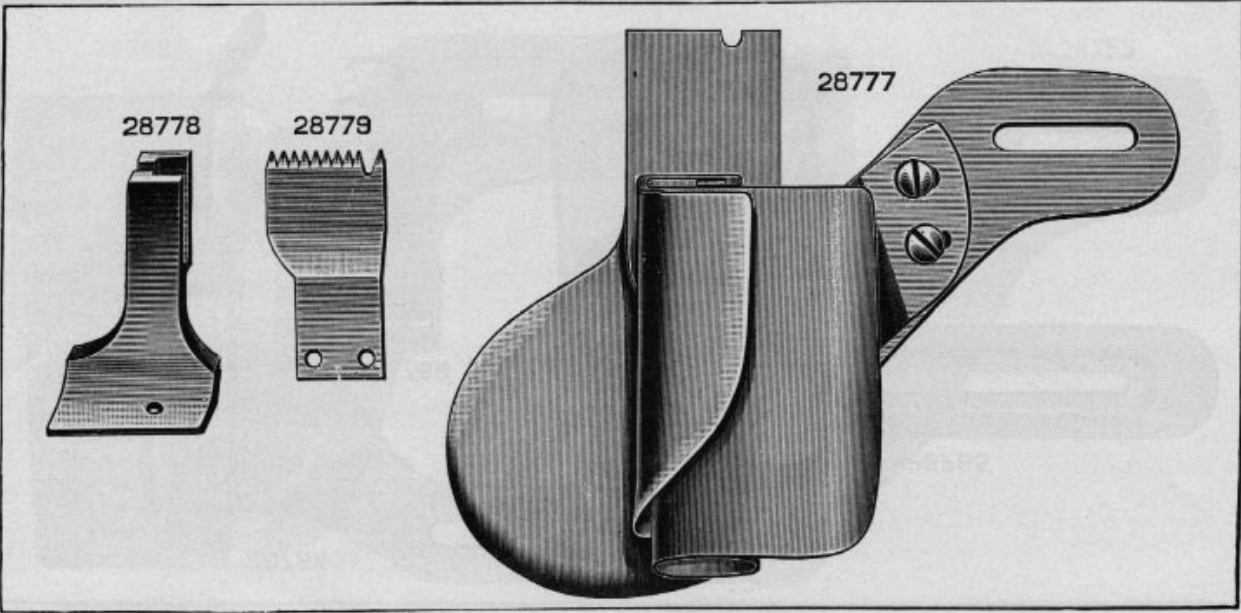


PLATE 2623—FULL SIZE

PLATE 2624—FULL SIZE

28358

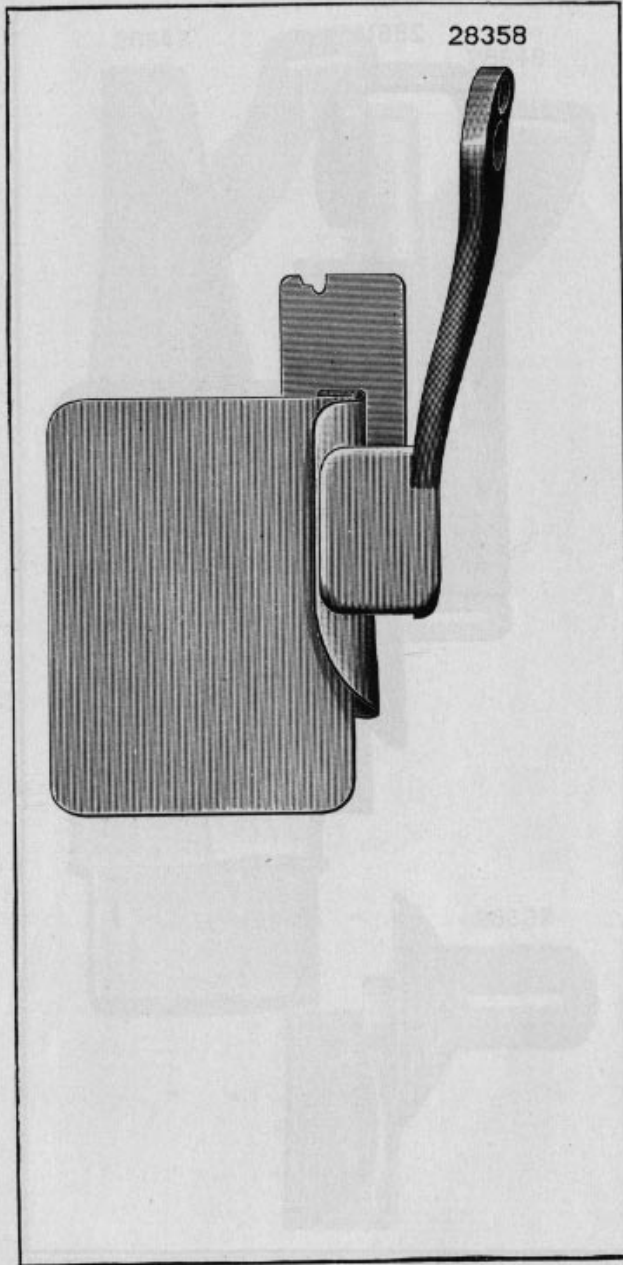




PLATE 2625—FULL SIZE

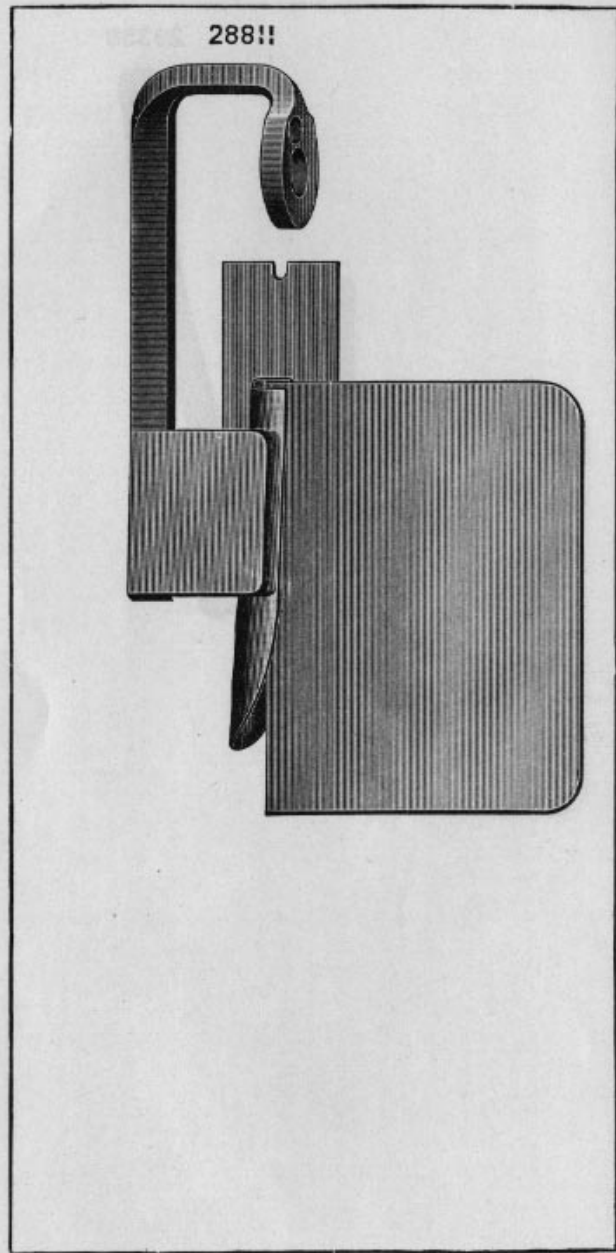


PLATE 2626—ONE-HALF SIZE

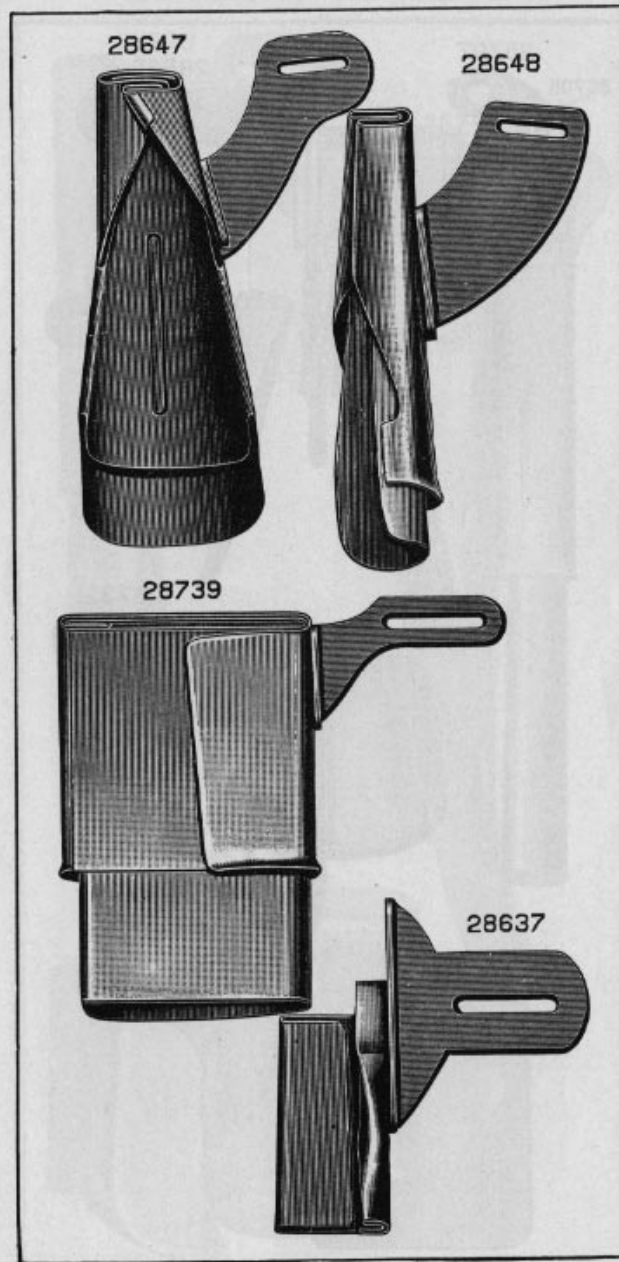


PLATE 2627—ONE-HALF SIZE

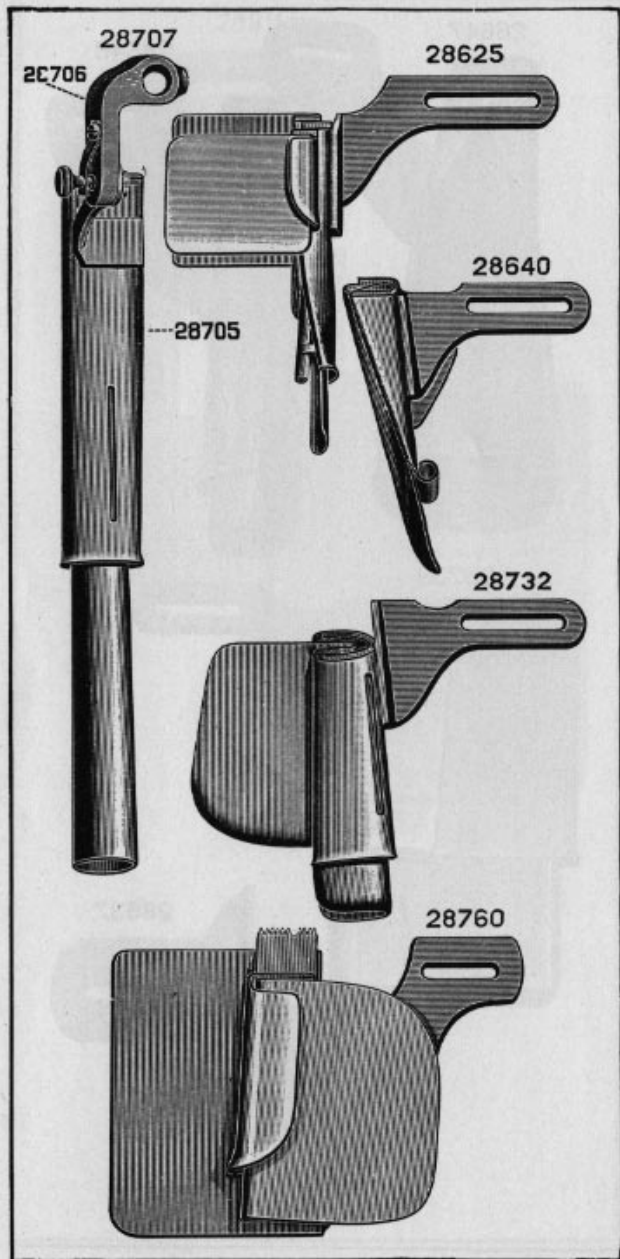


PLATE 2628—ONE-HALF SIZE

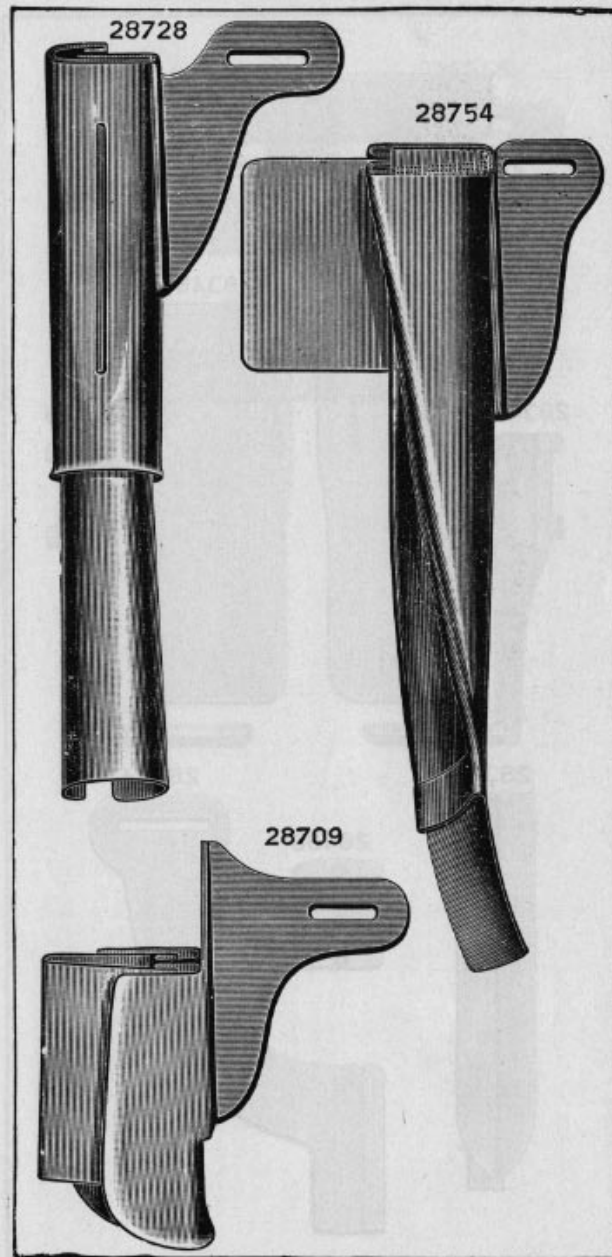




PLATE 2632—ONE-HALF SIZE

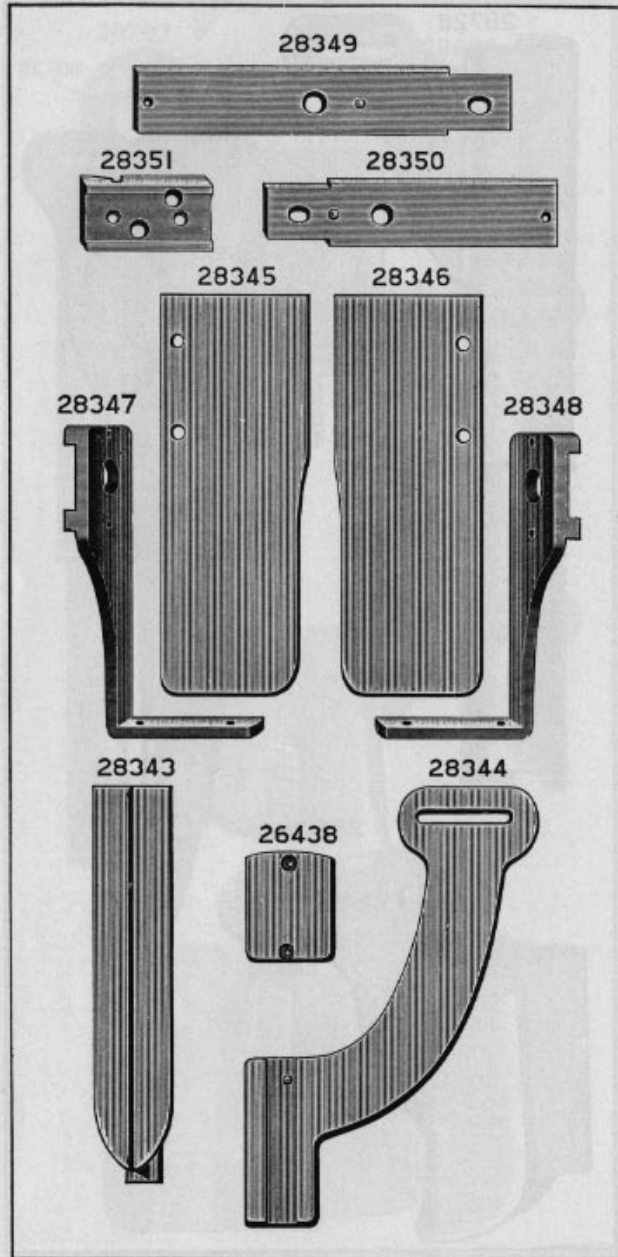


PLATE 2633—FULL SIZE

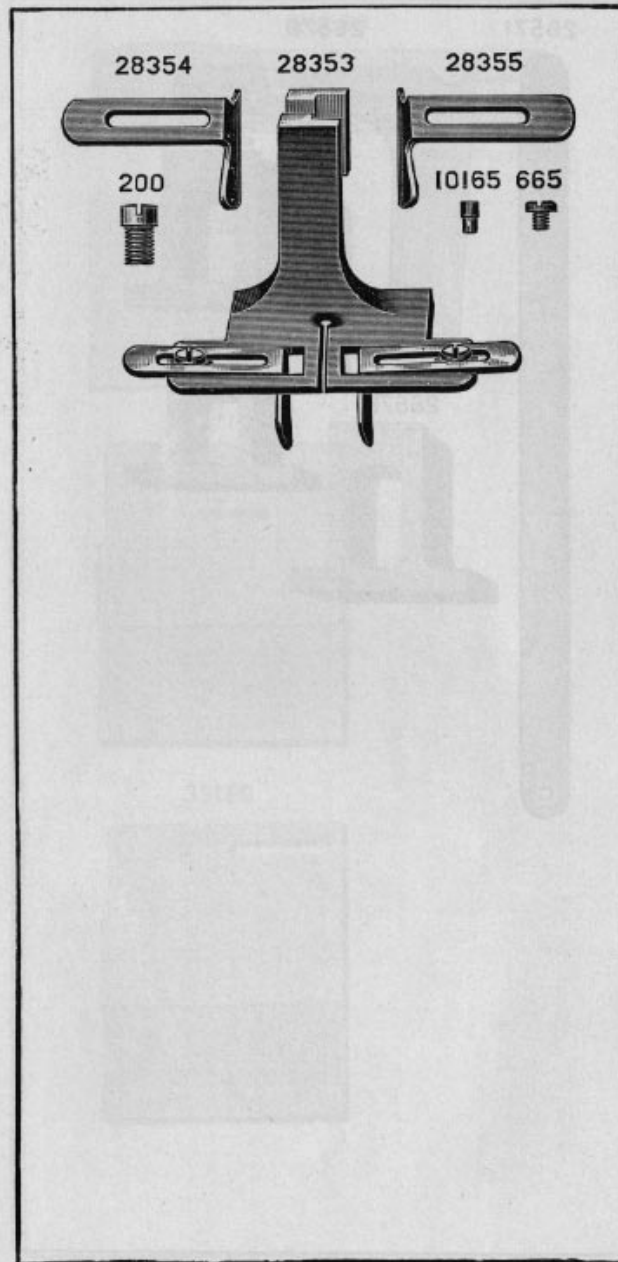


PLATE 2634—ONE-FOURTH SIZE

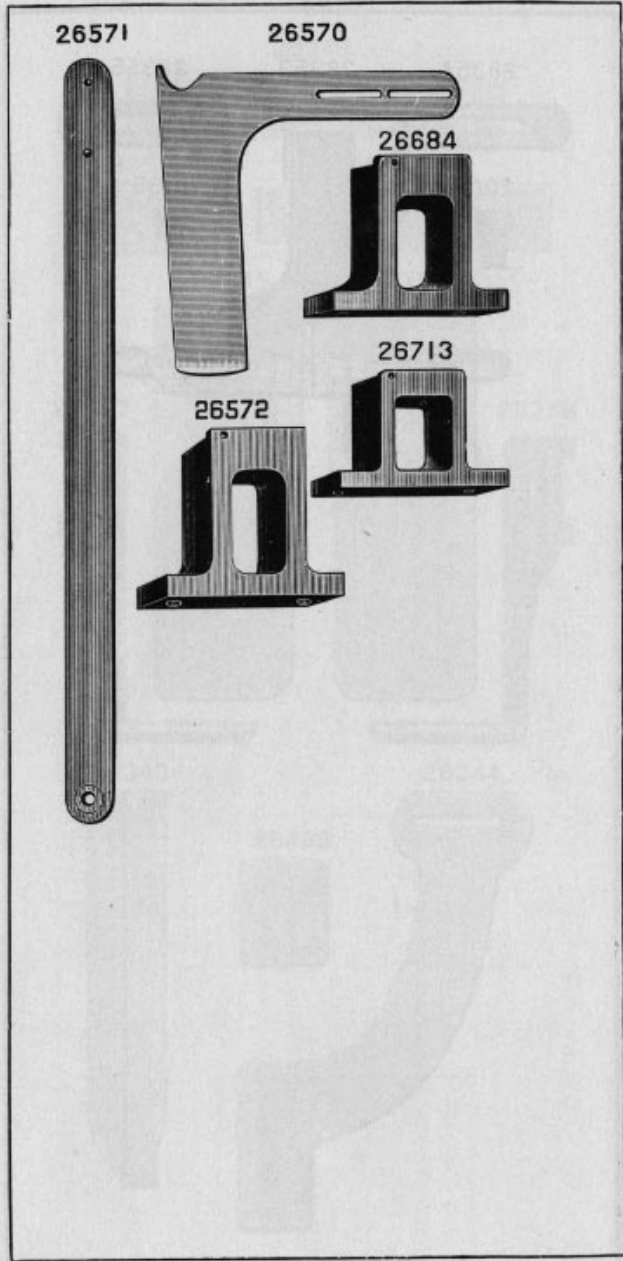


PLATE 2635—ONE-HALF SIZE

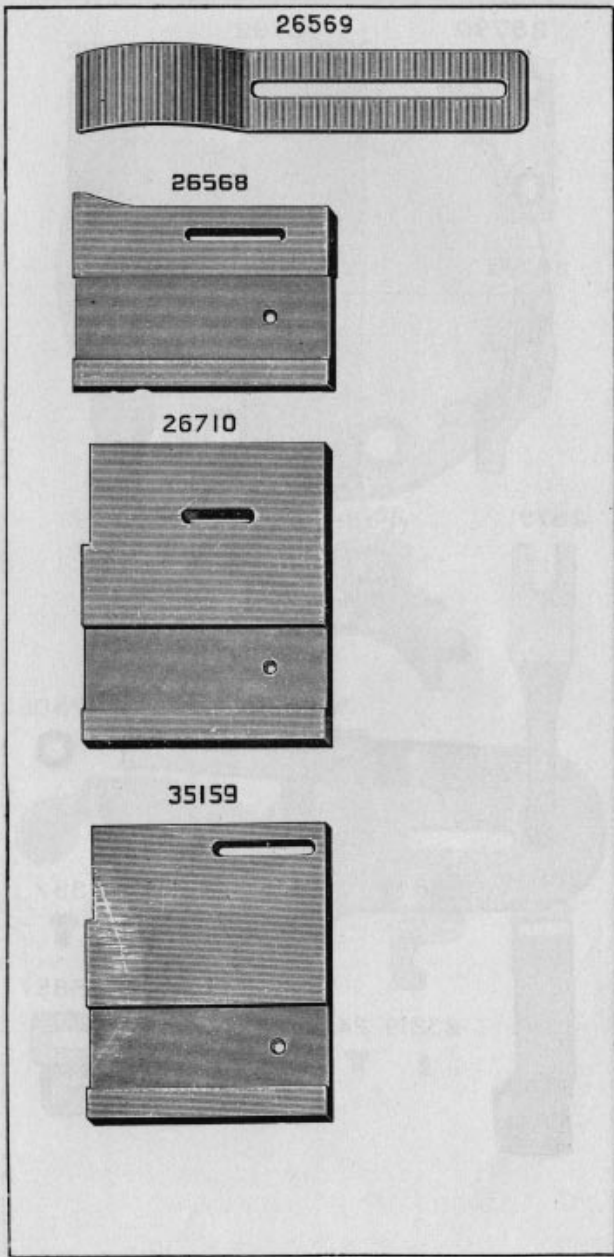


PLATE 2645—FULL SIZE

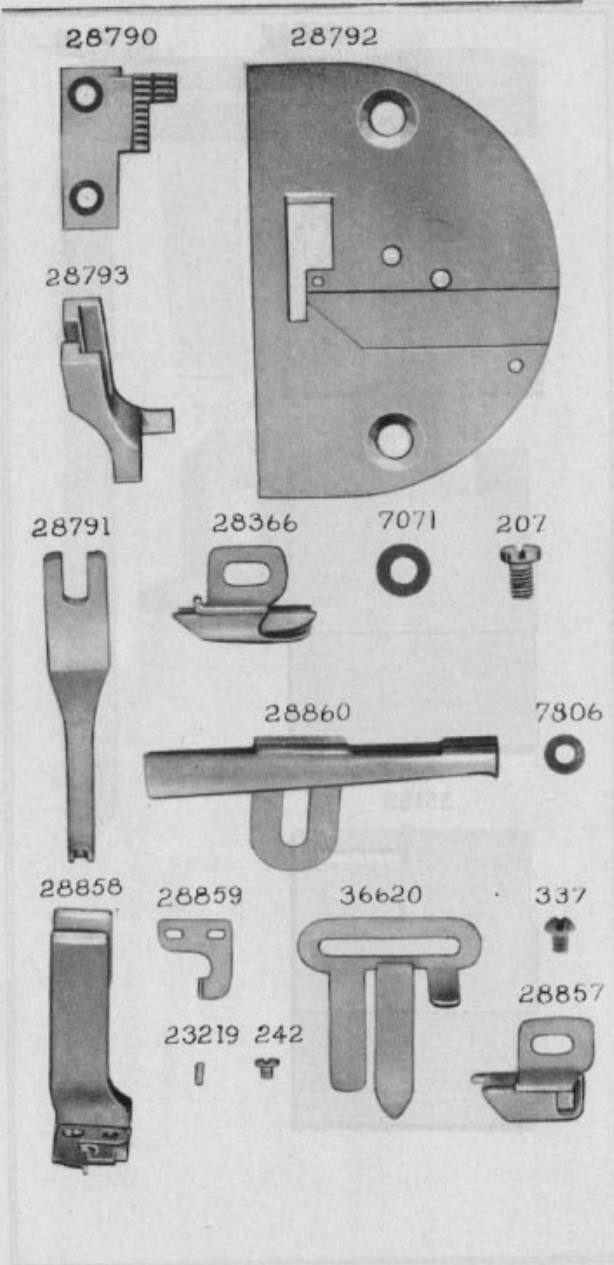
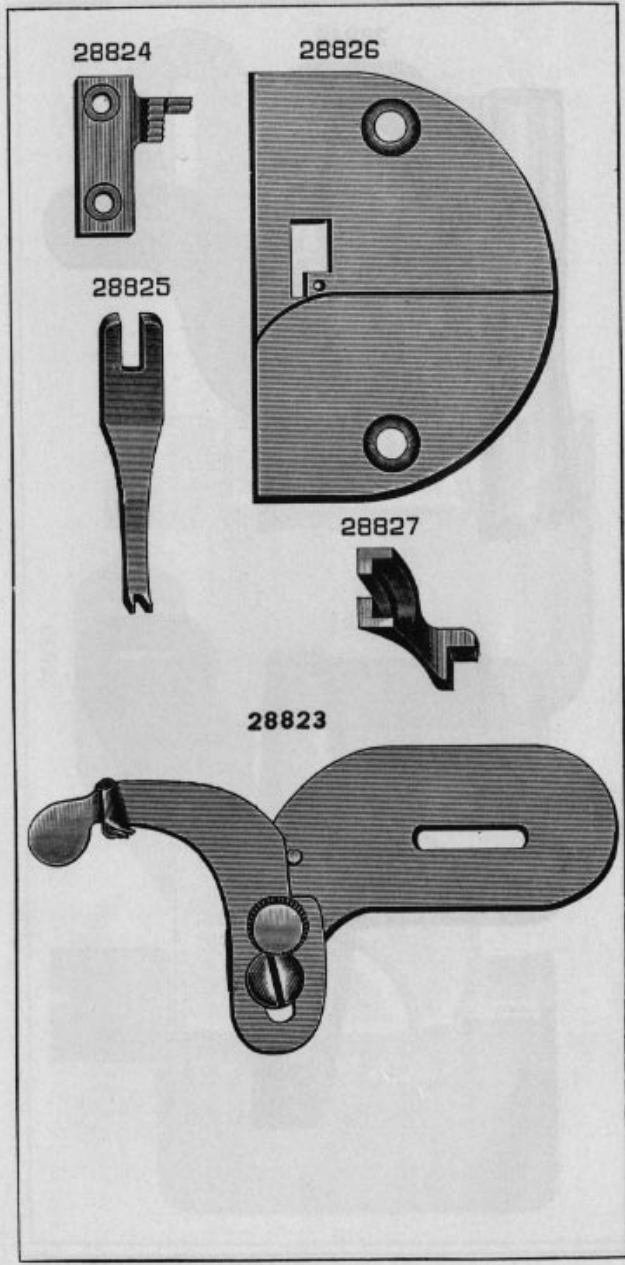
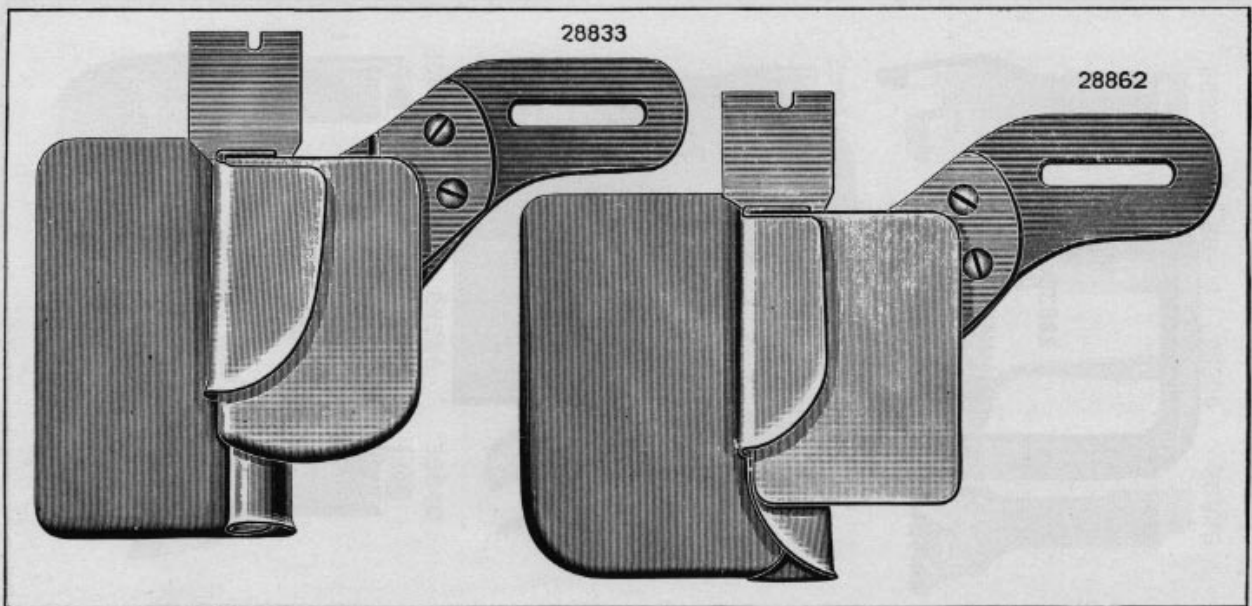


PLATE 2646—FULL SIZE





28833

28862

PLATE 2649—FULL SIZE

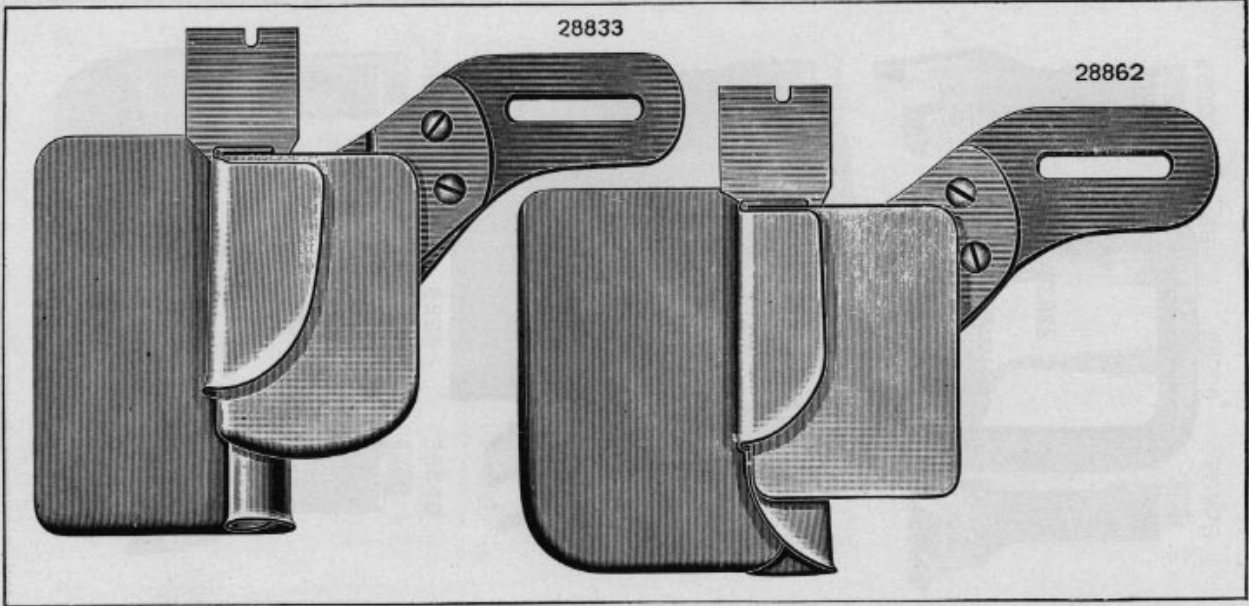


PLATE 2649—FULL SIZE



PLATE 2650—FULL SIZE

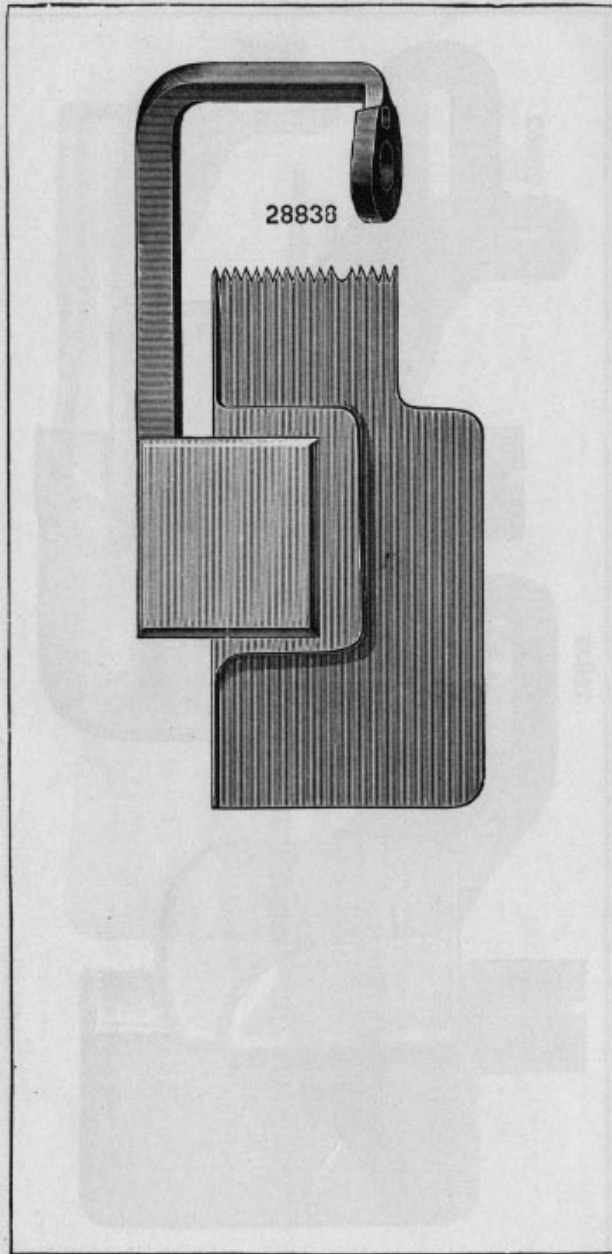
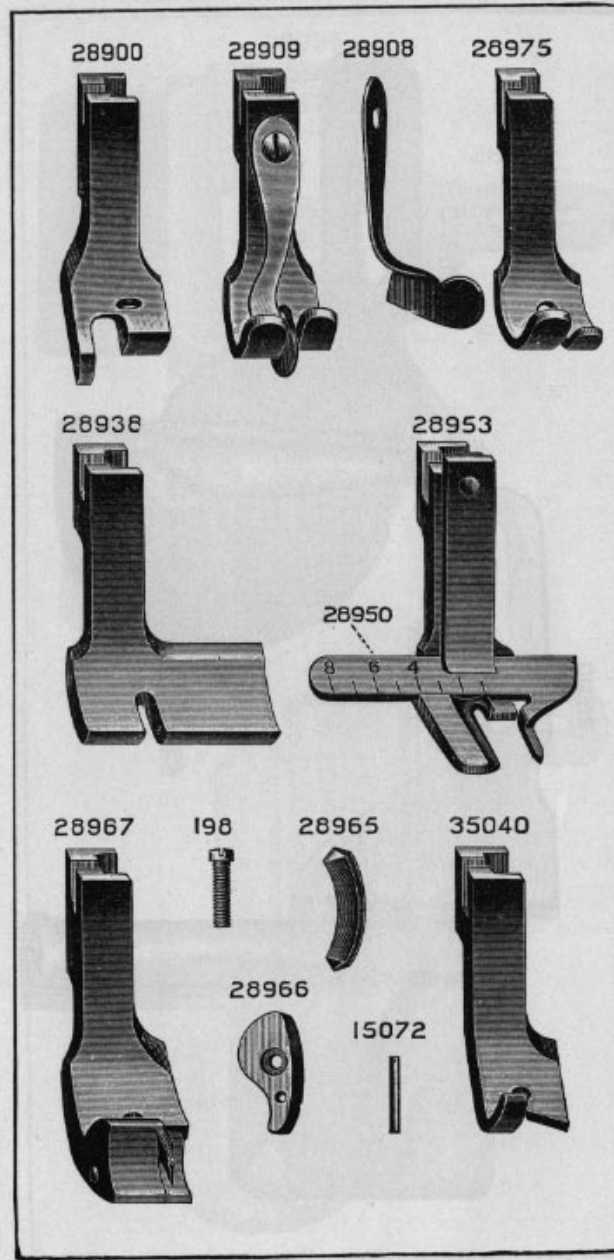
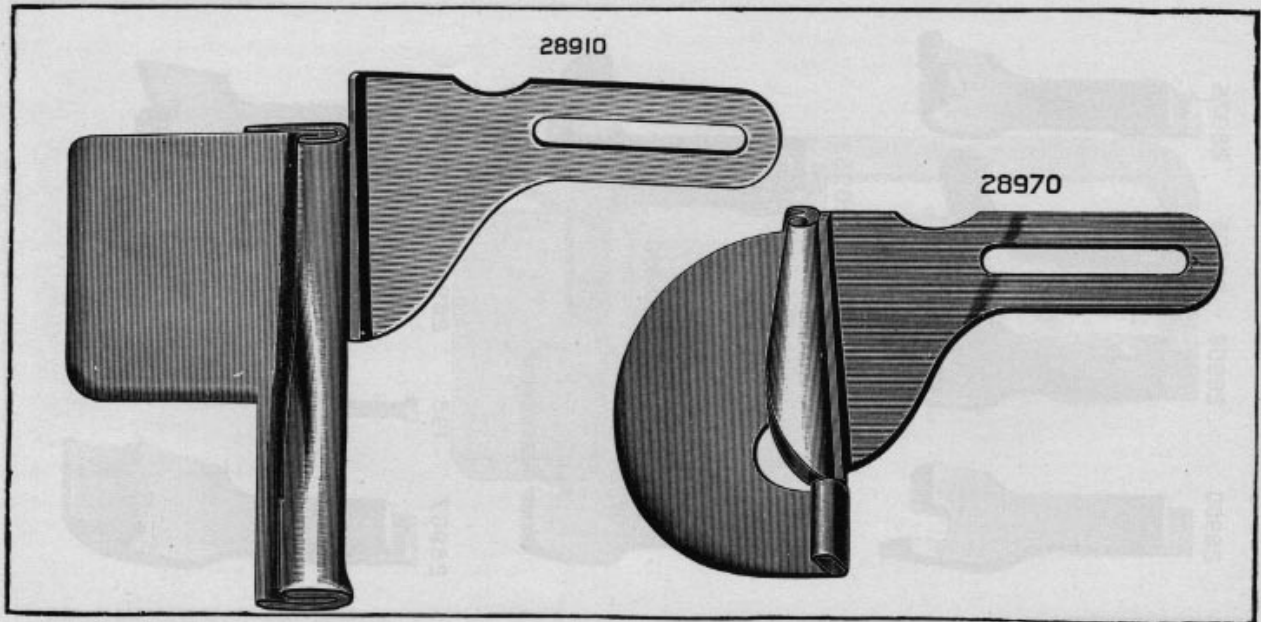


PLATE 2658—FULL SIZE





28910

28970

PLATE 2659—FULL SIZE

PLATE 2661—ONE-HALF SIZE

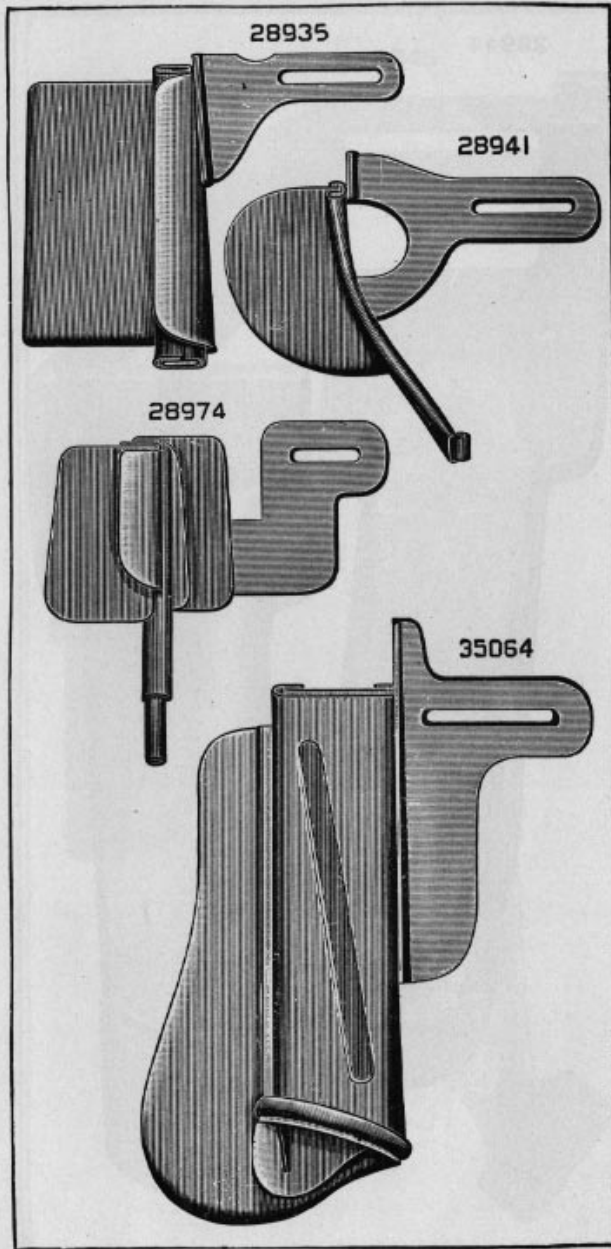




PLATE 2665—FULL SIZE

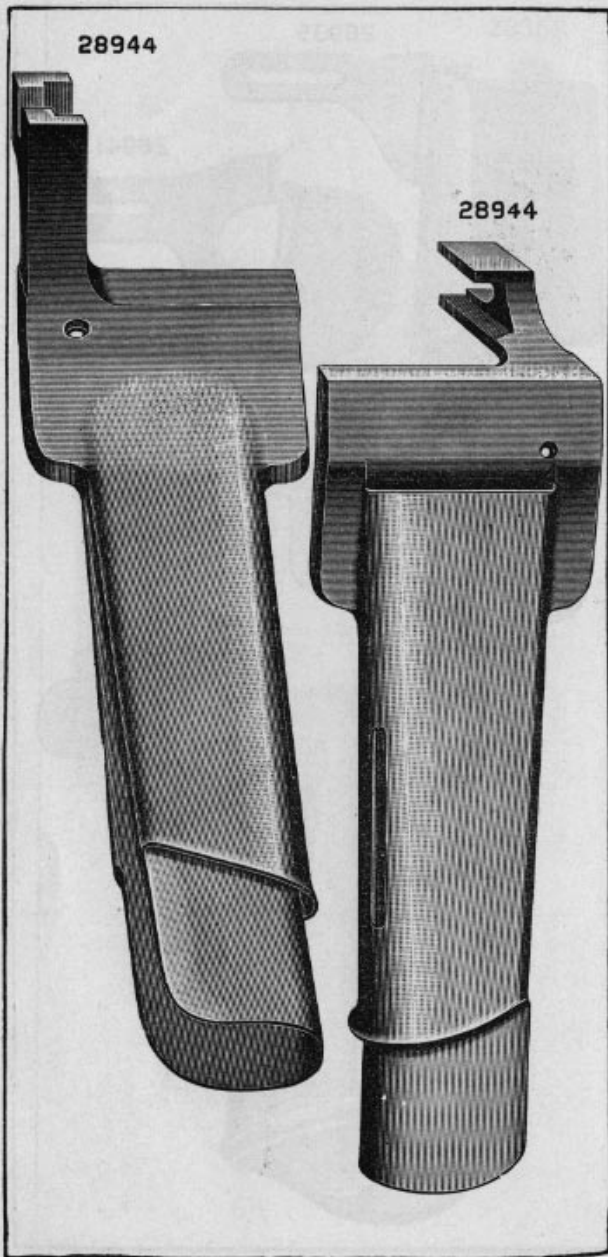
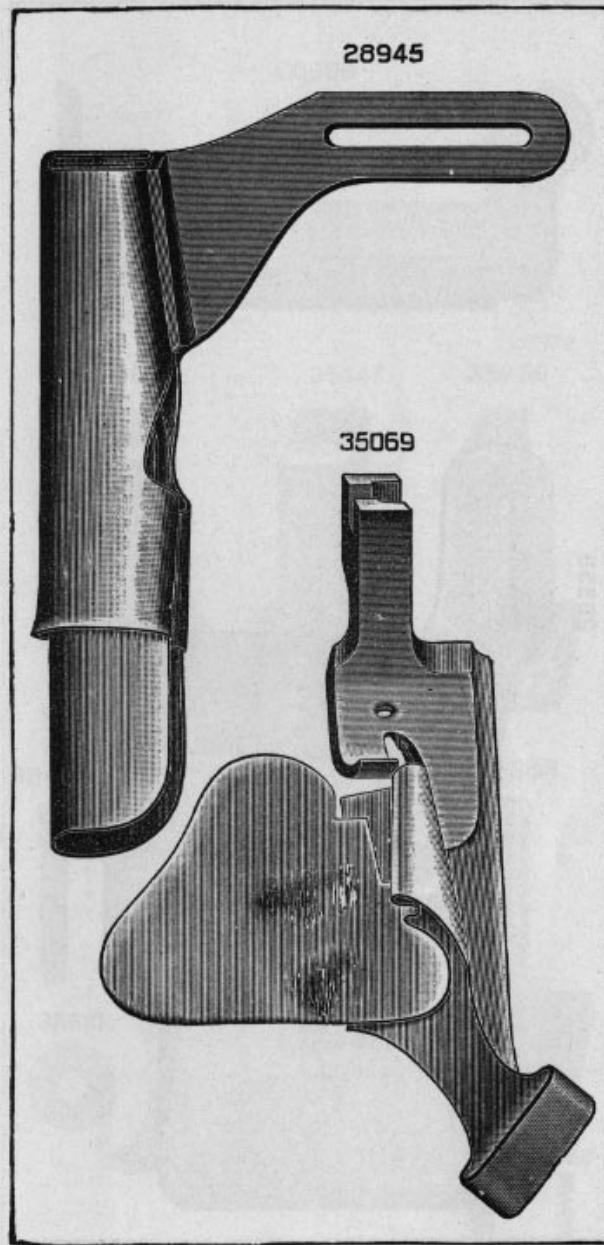
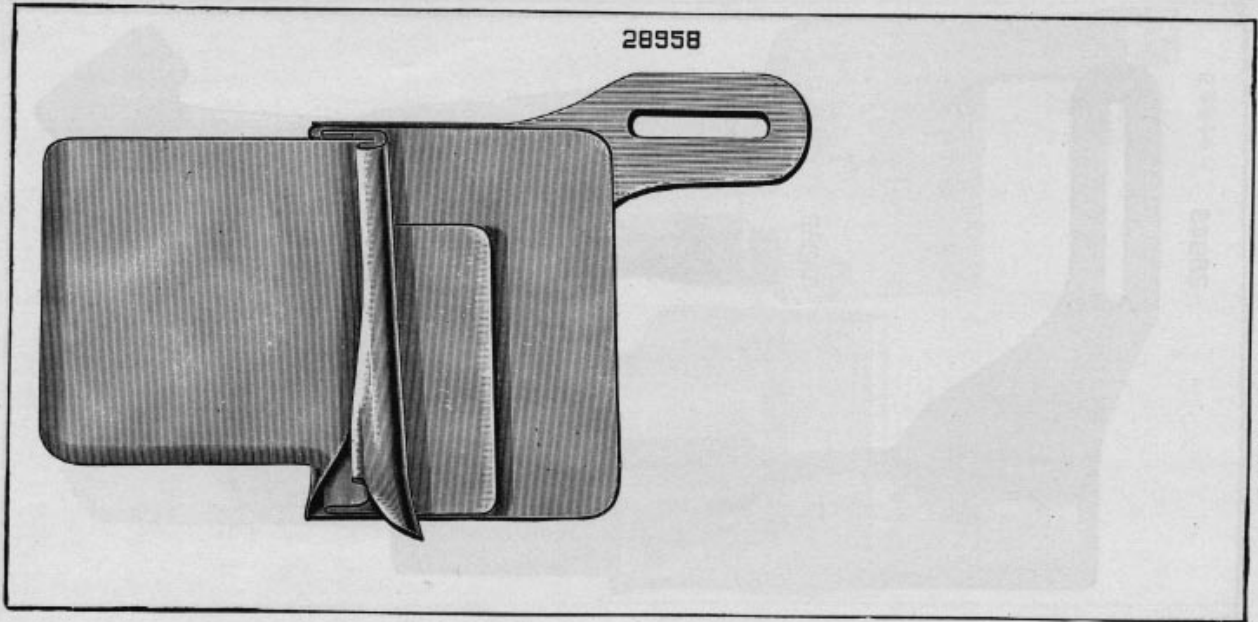


PLATE 2666—FULL SIZE





28958

PLATE 2668—FULL SIZE

PLATE 2669—FULL SIZE

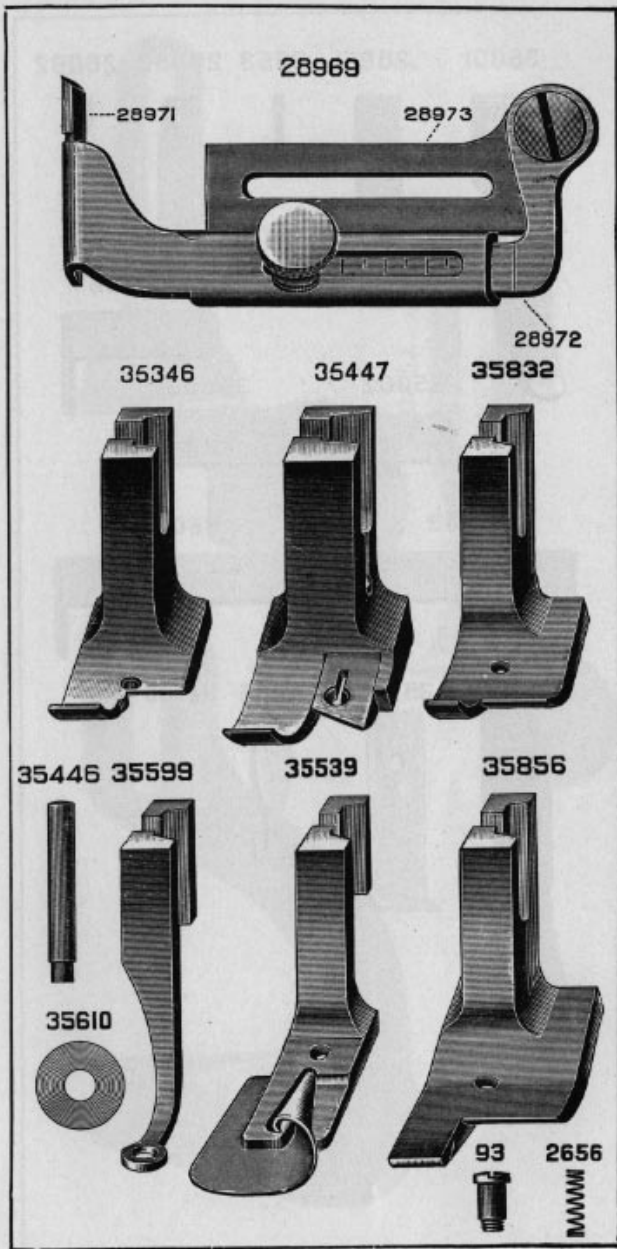
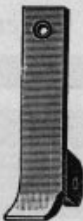
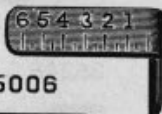


PLATE 2671—FULL SIZE

35001 28951 2653 28952 26092



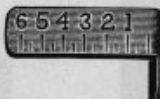
35006



35002



35006



35003



35004



35134



35135



35136



36696

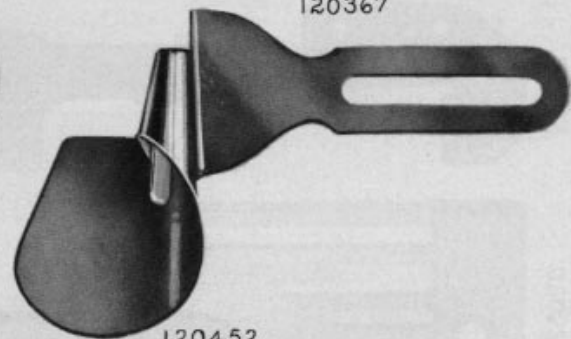


337

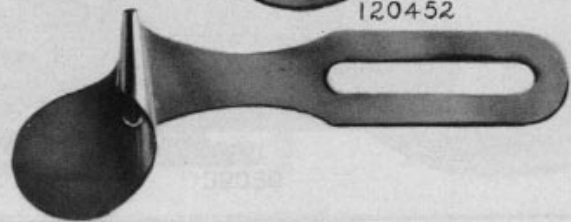




35023



120367

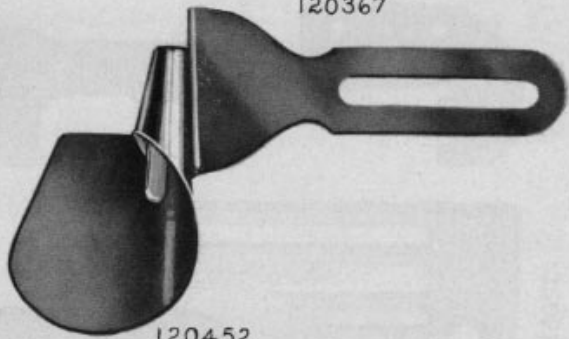


120452

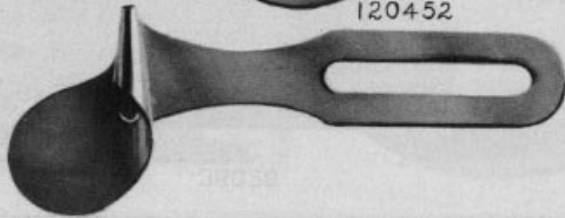
PLATE 2672-FULL SIZE



35023

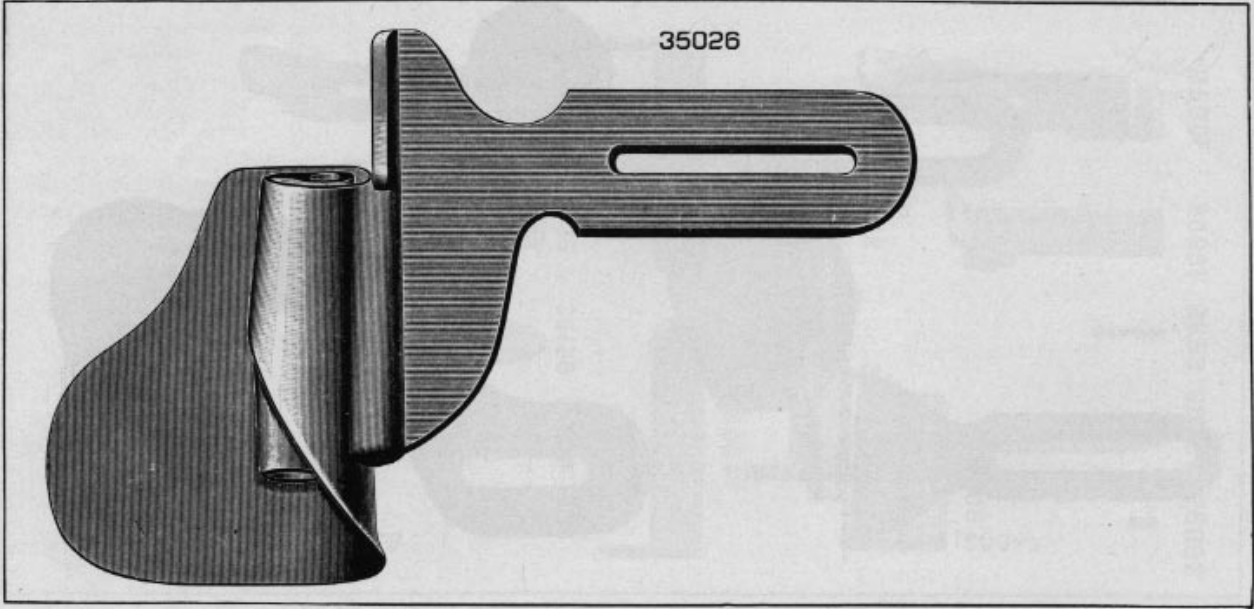


120367



120452

PLATE 2672-FULL SIZE



35026

PLATE 2673-FULL SIZE

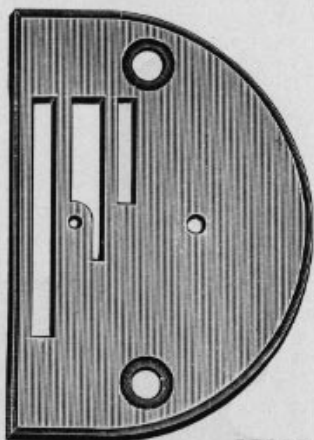


PLATE 2674—FULL SIZE

35027



35029



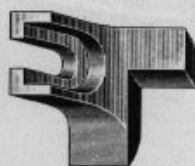
35028



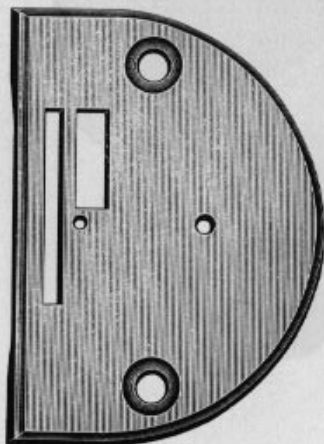
35232



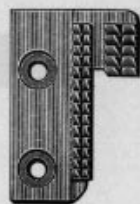
35233



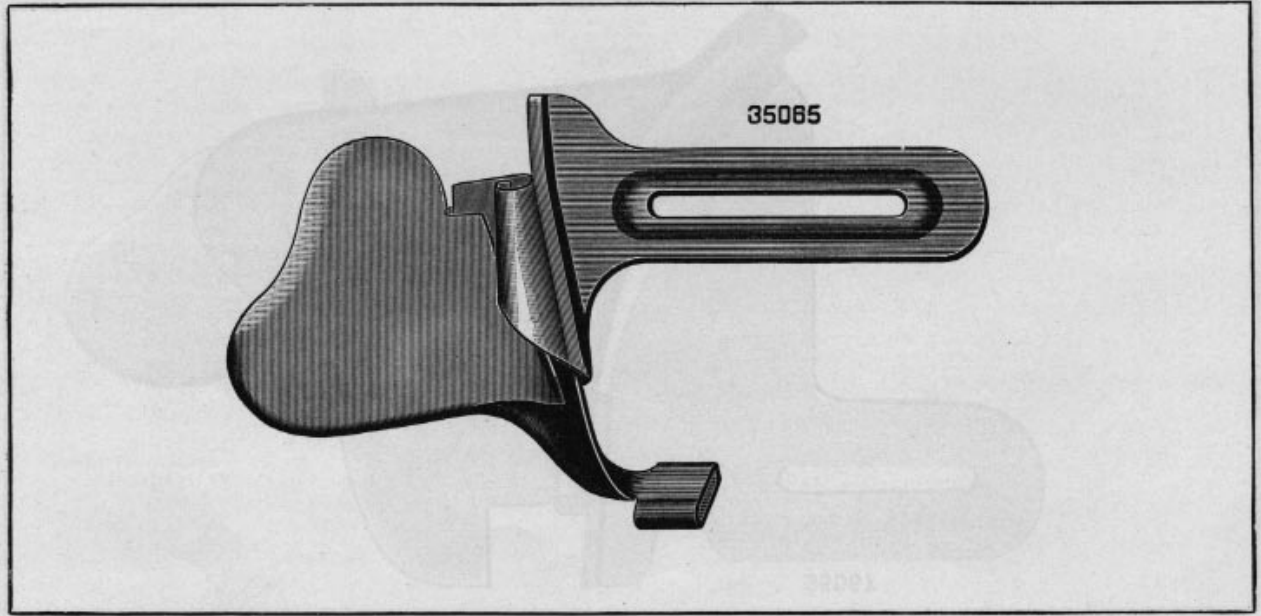
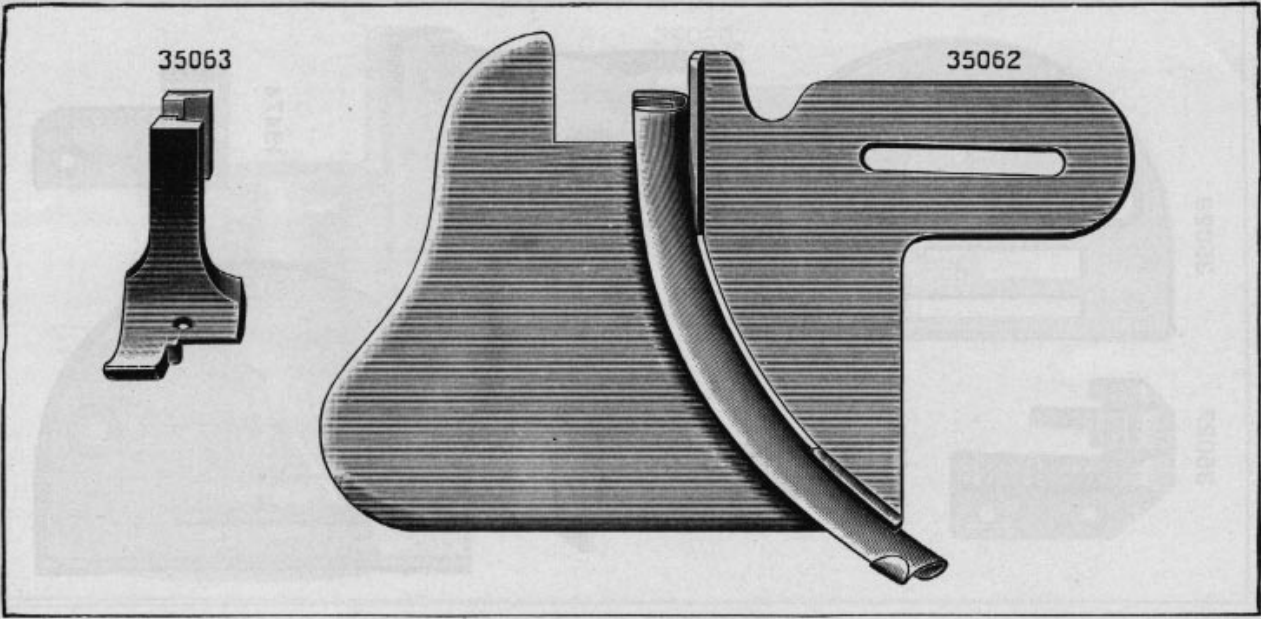
19475

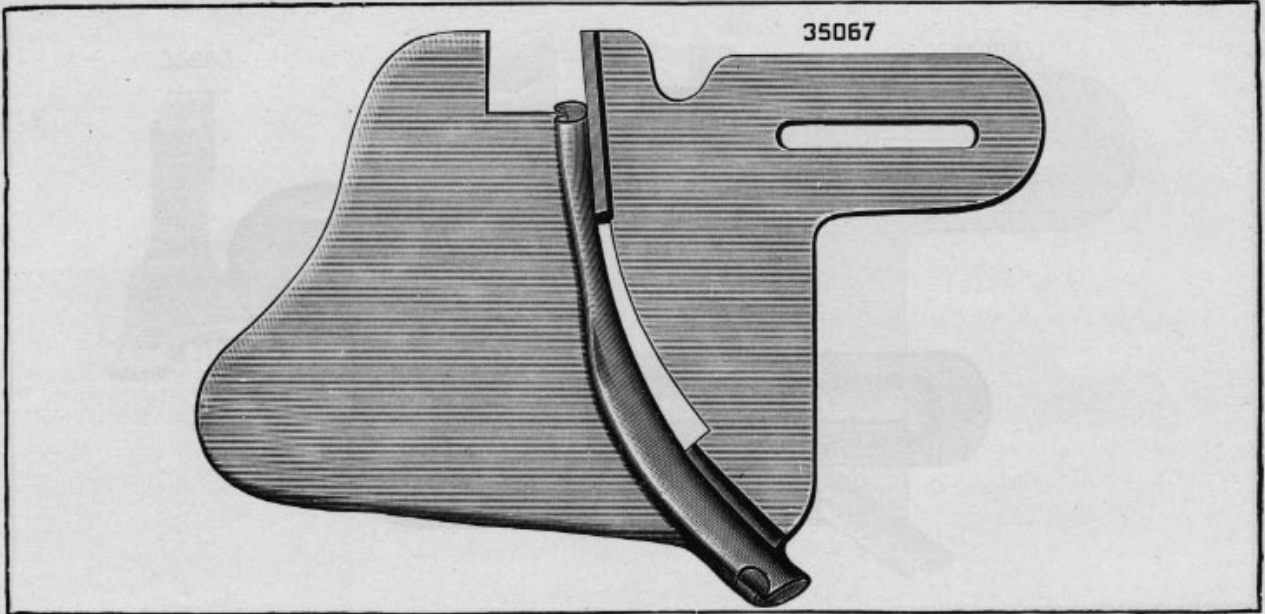


19474



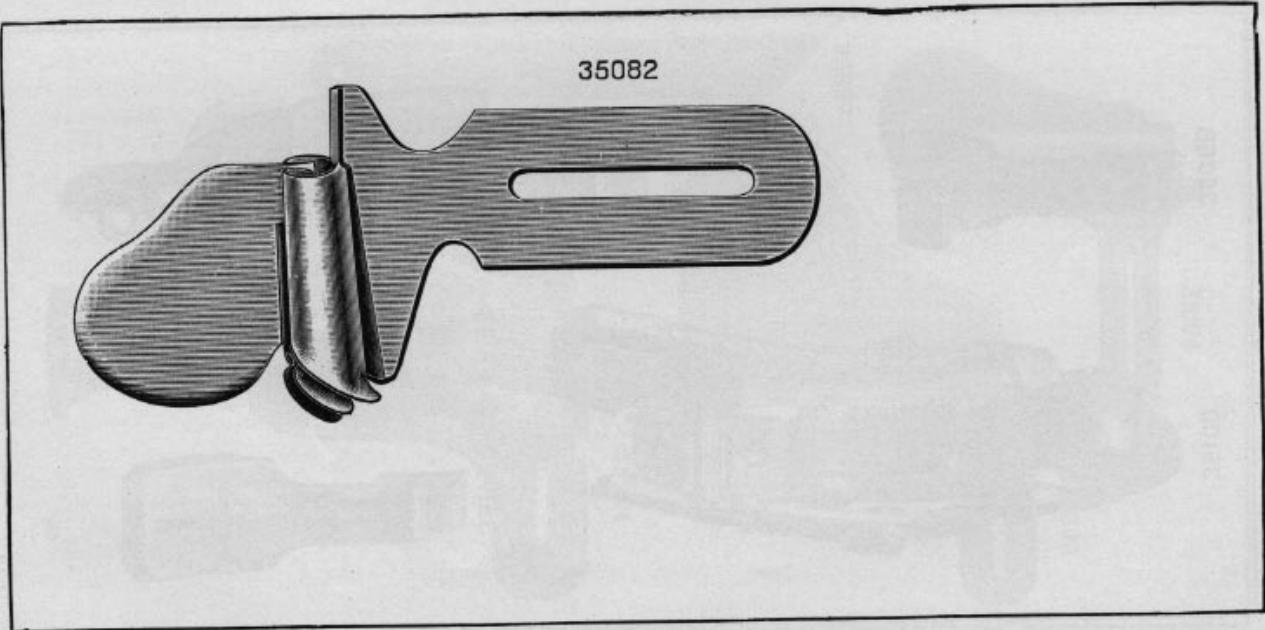






35067

PLATE 2678—FULL SIZE



35082

PLATE 2680—FULL SIZE

PLATE 2682—FULL SIZE

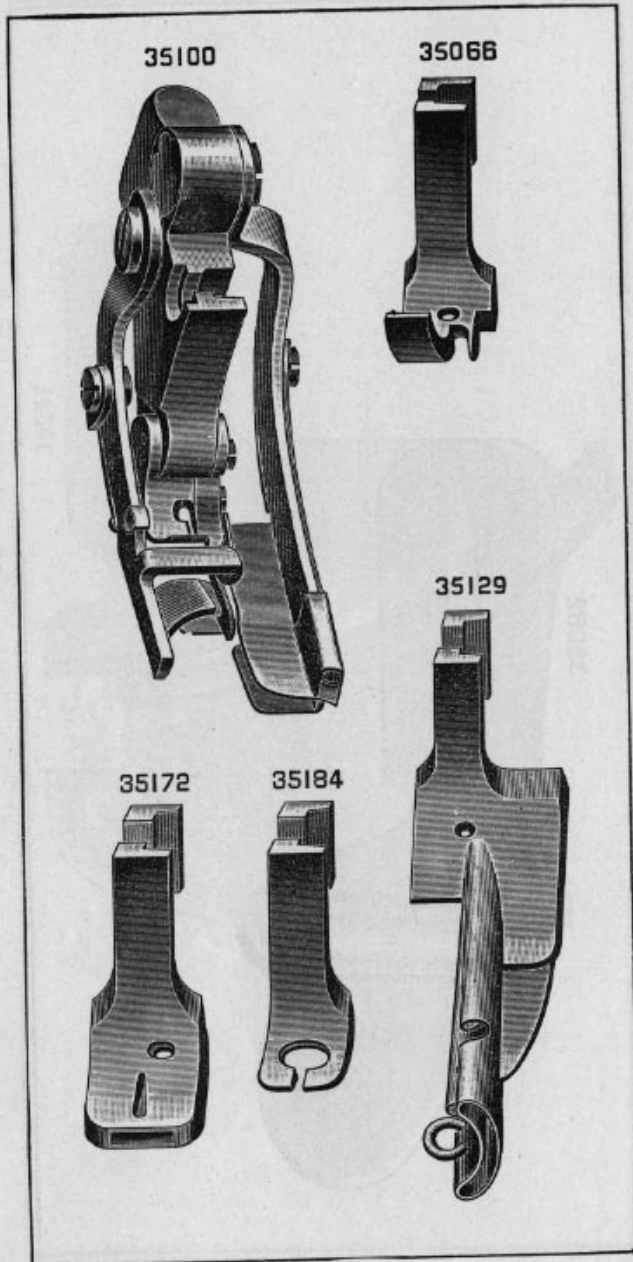
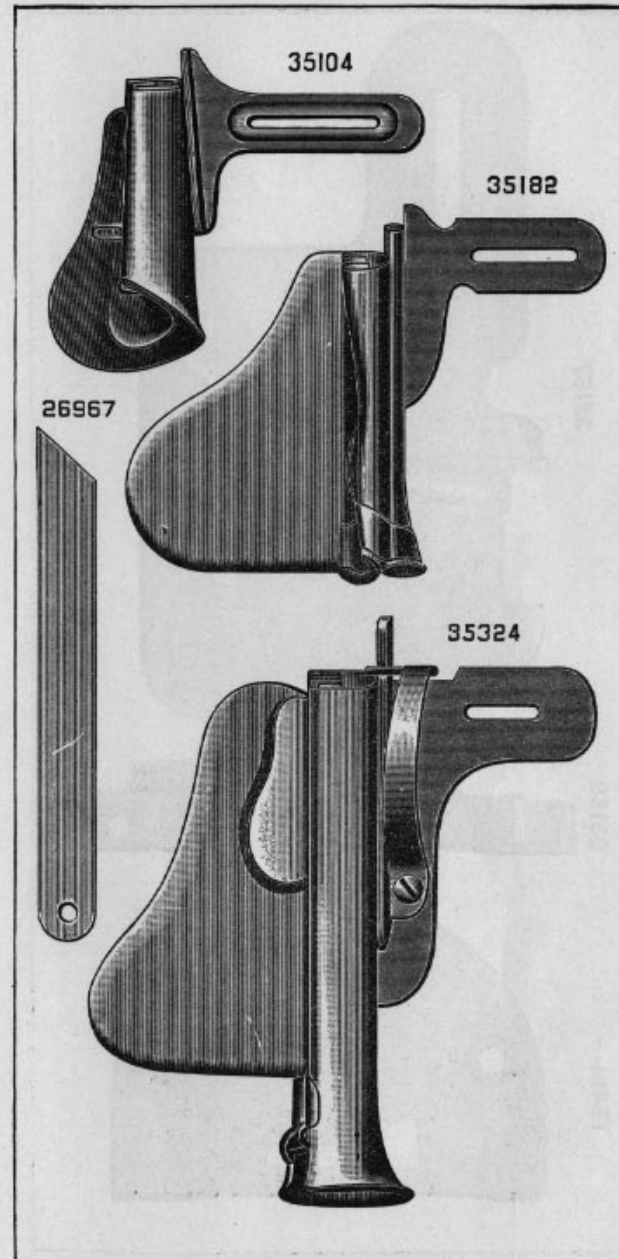


PLATE 2684—ONE-HALF SIZE



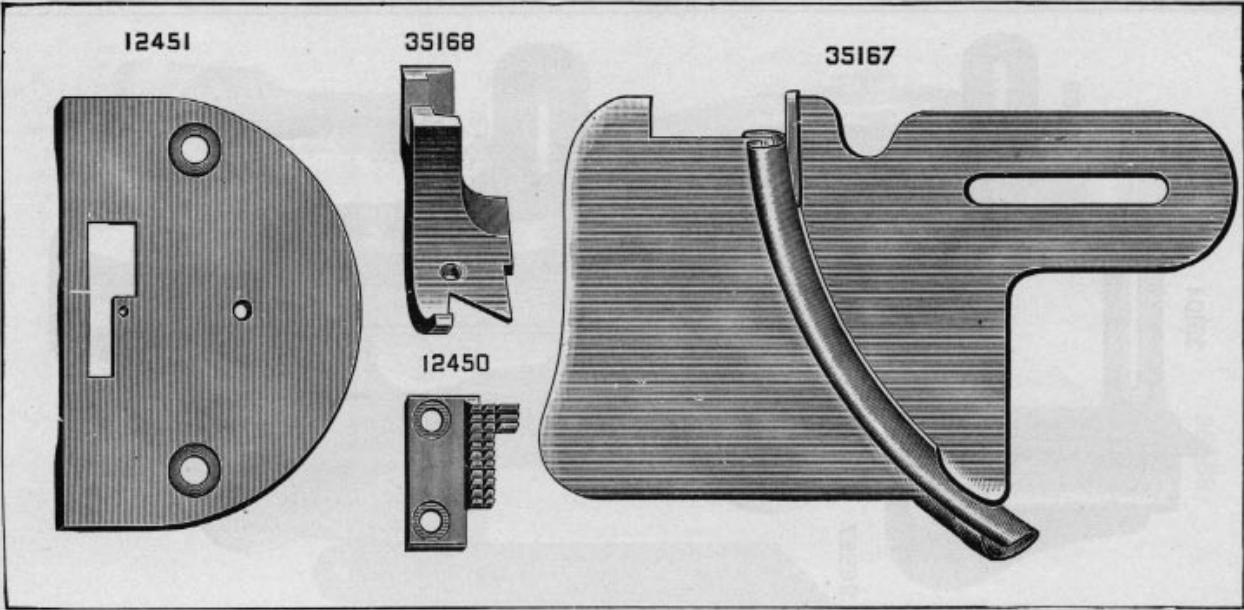


PLATE 2689—FULL SIZE

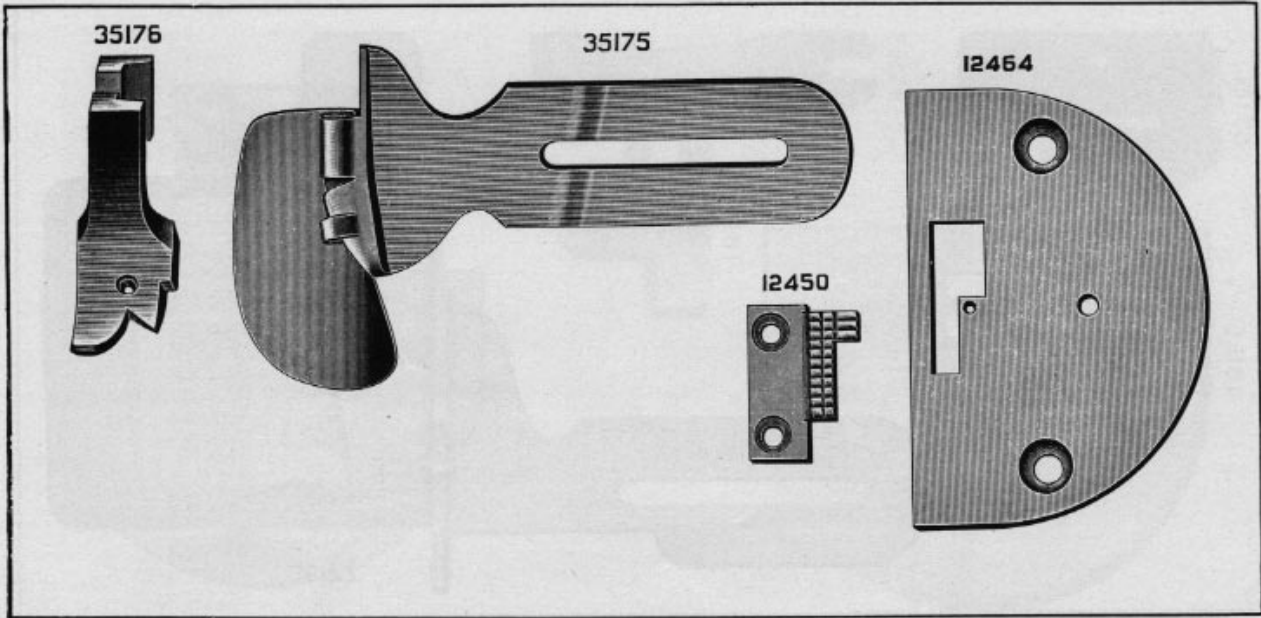


PLATE 2690—FULL SIZE

35177

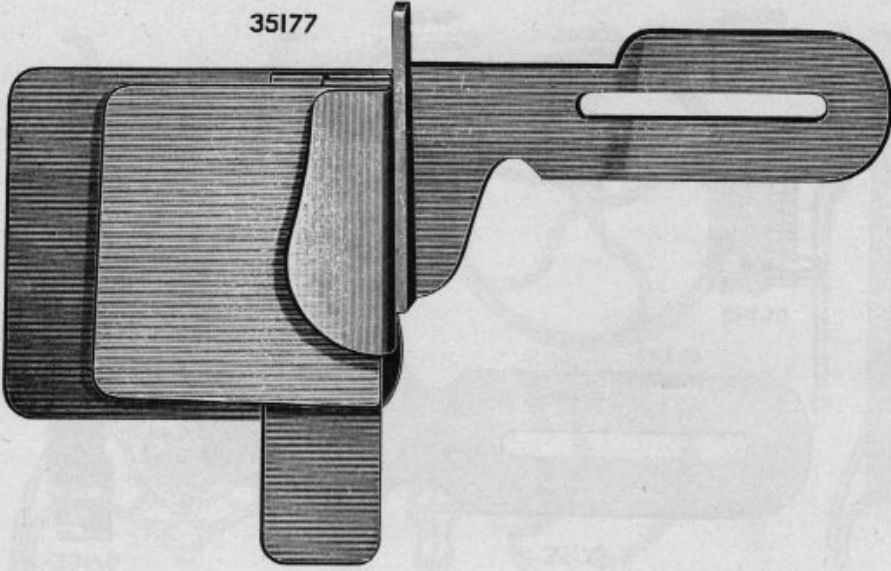
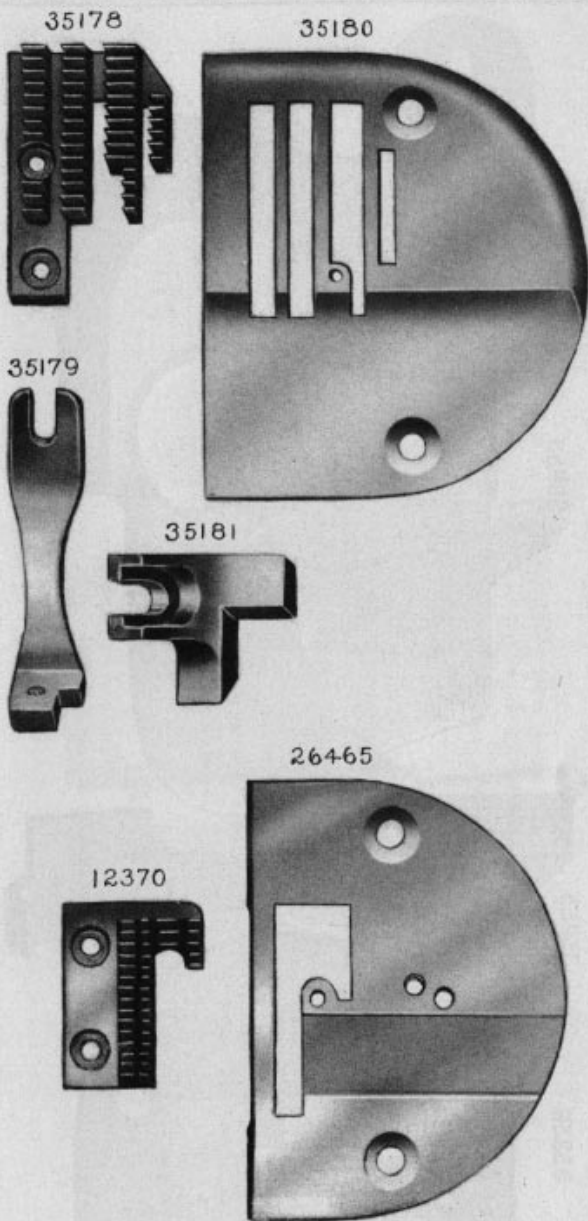


PLATE 2691—FULL SIZE



PLATE 2692—FULL SIZE



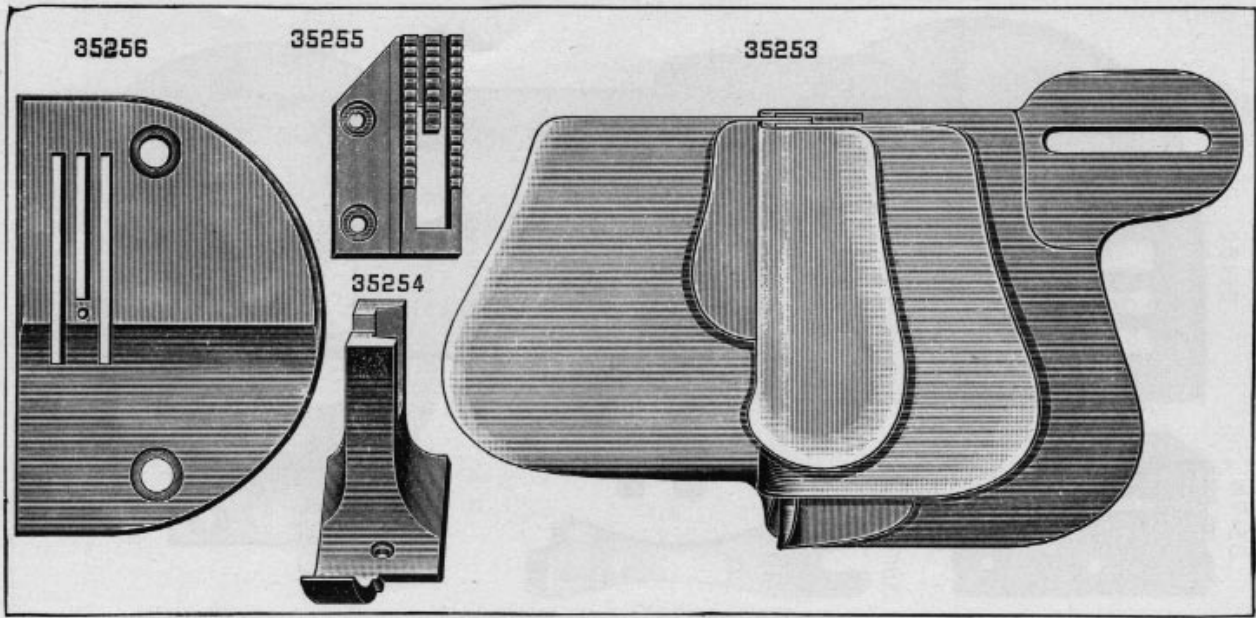


PLATE 2693—FULL SIZE

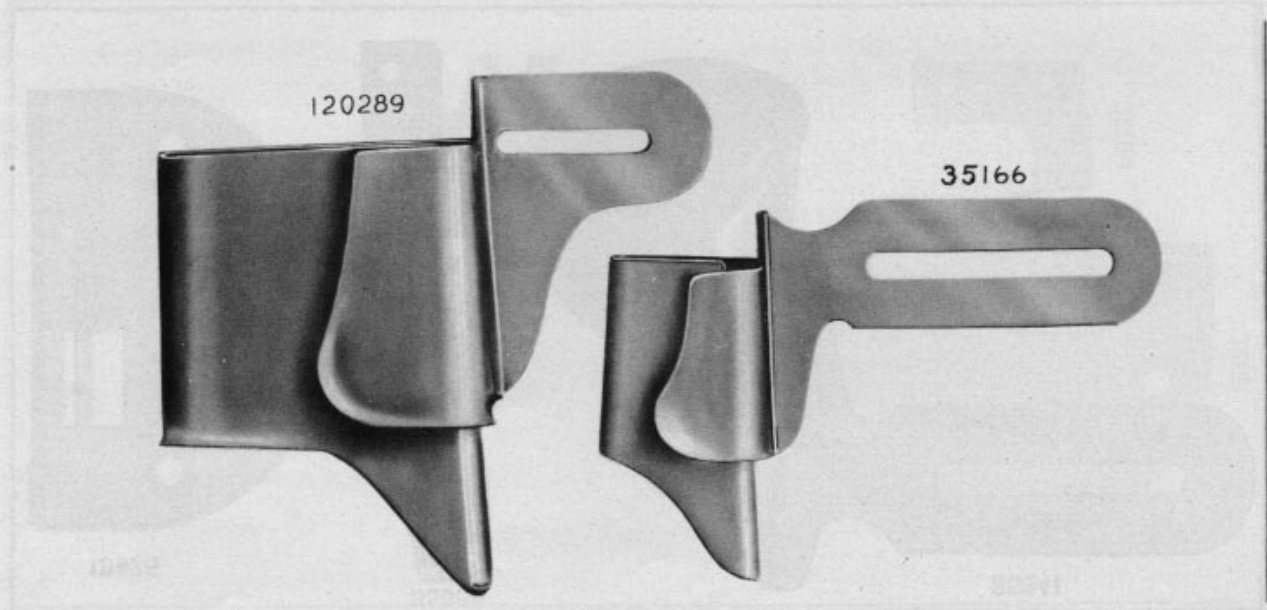


PLATE 2694—FULL SIZE

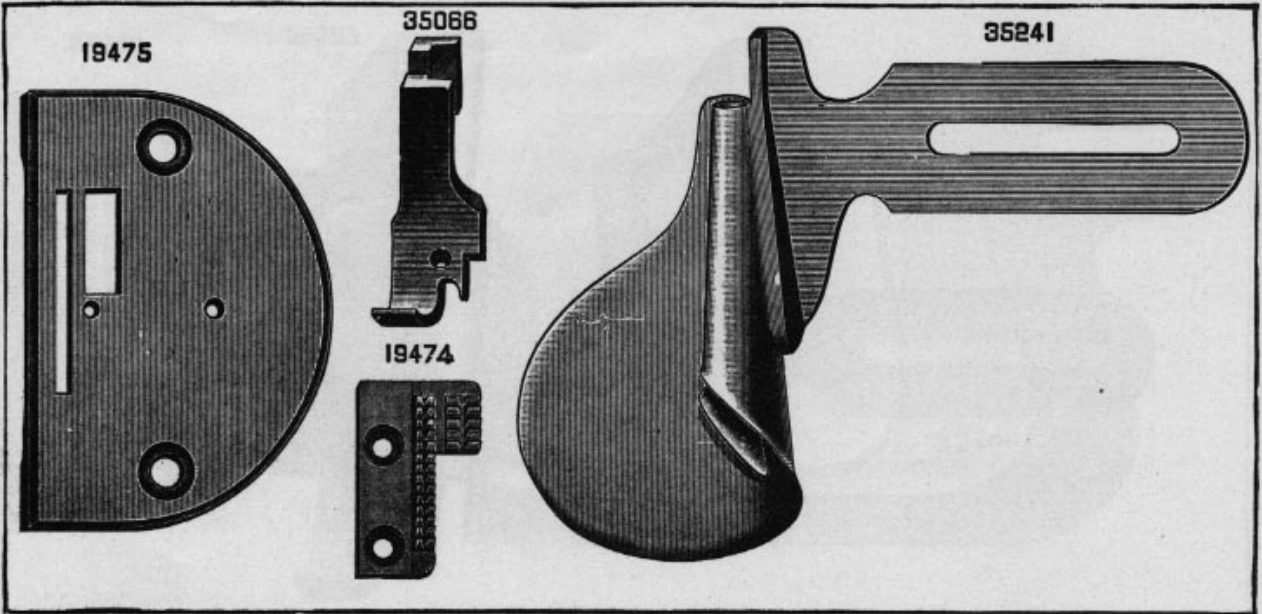


PLATE 2695—FULL SIZE



PLATE 2697—FULL SIZE

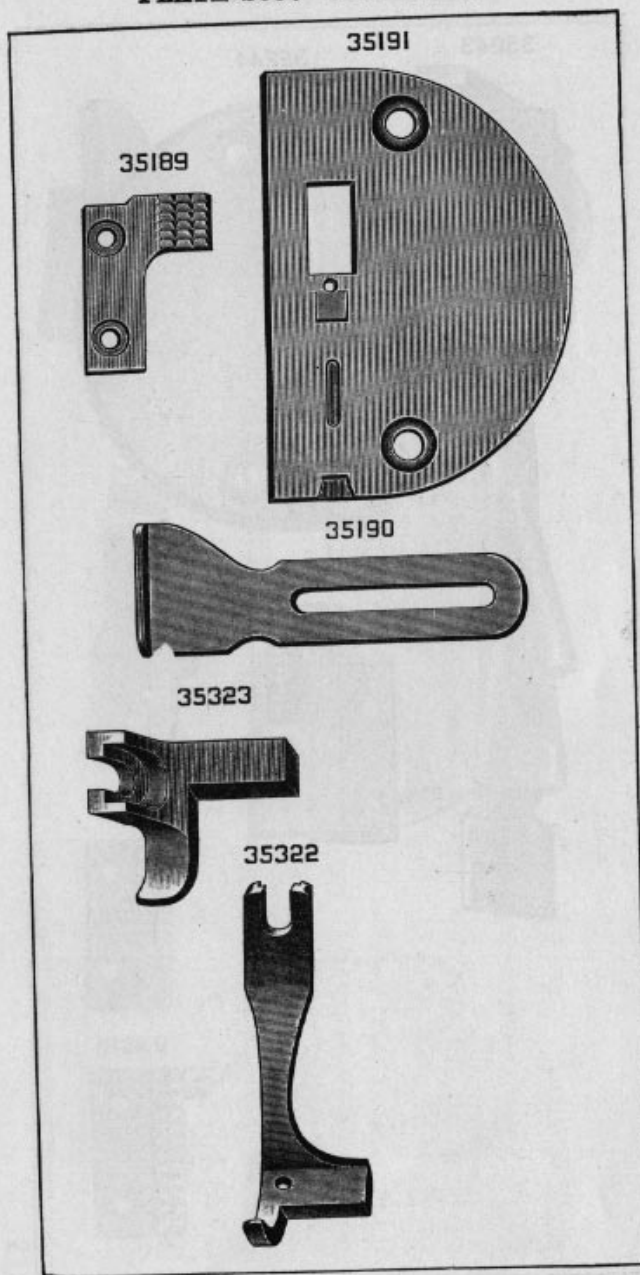


PLATE 2698—FULL SIZE

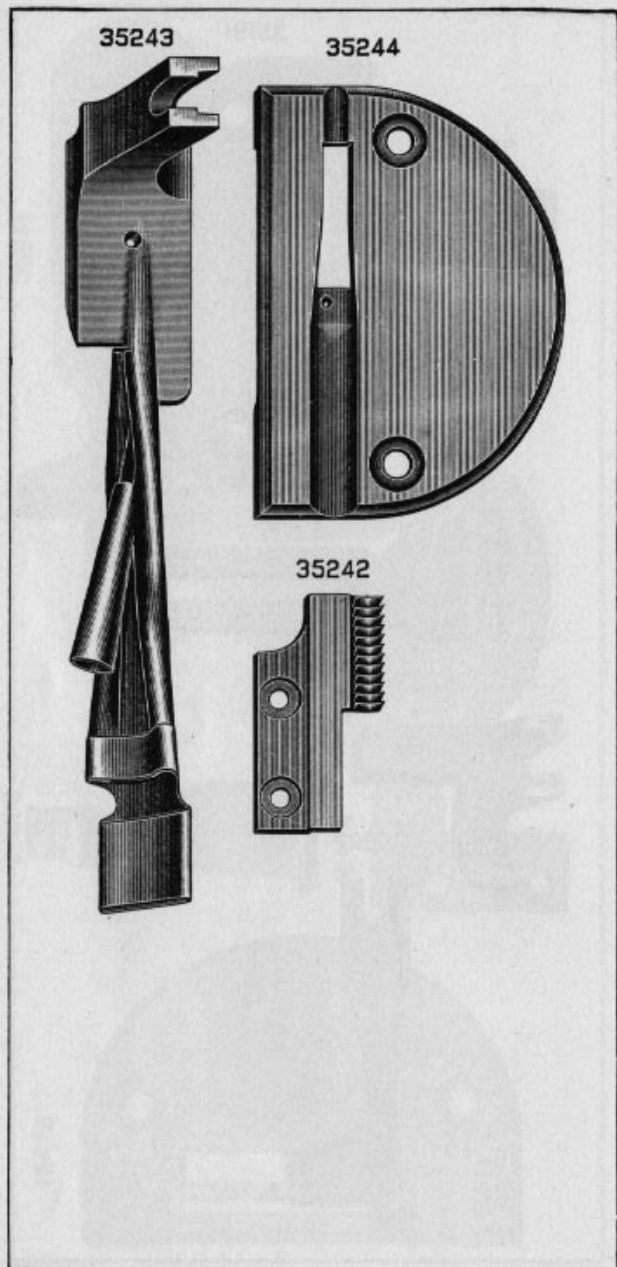
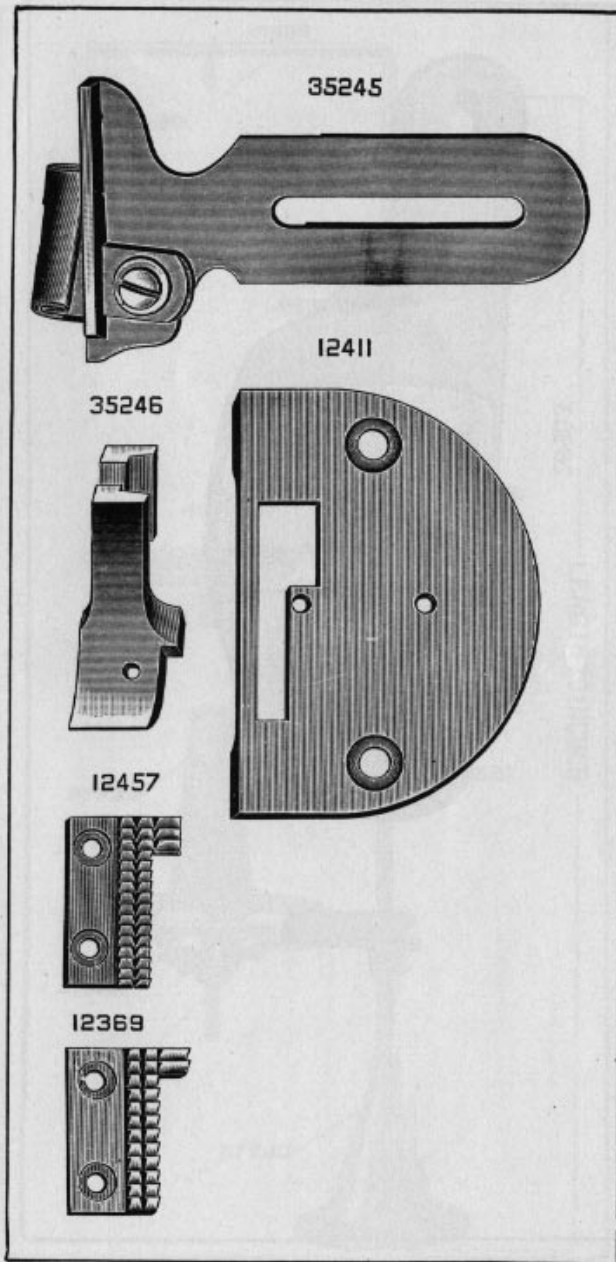


PLATE 2699—FULL SIZE



28903

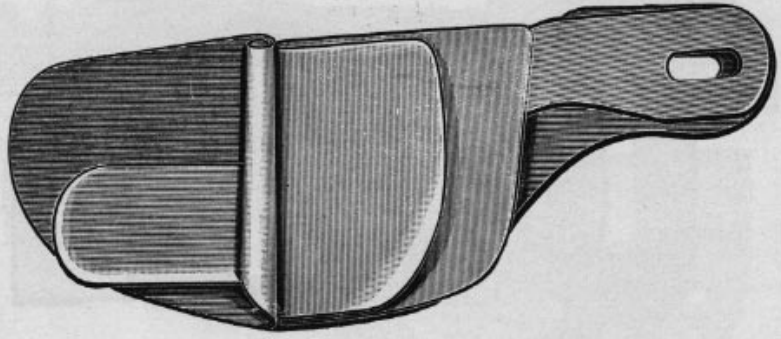


PLATE 2782—FULL SIZE

PLATE 2836—ONE-FOURTH SIZE

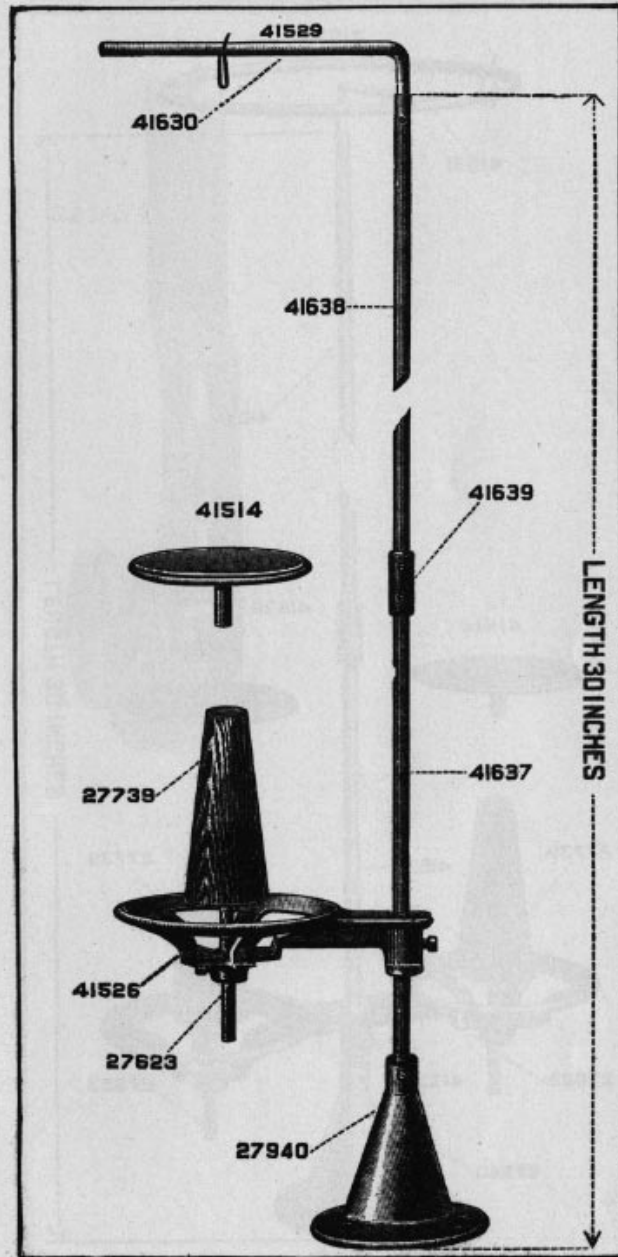


PLATE 2837—ONE-FOURTH SIZE

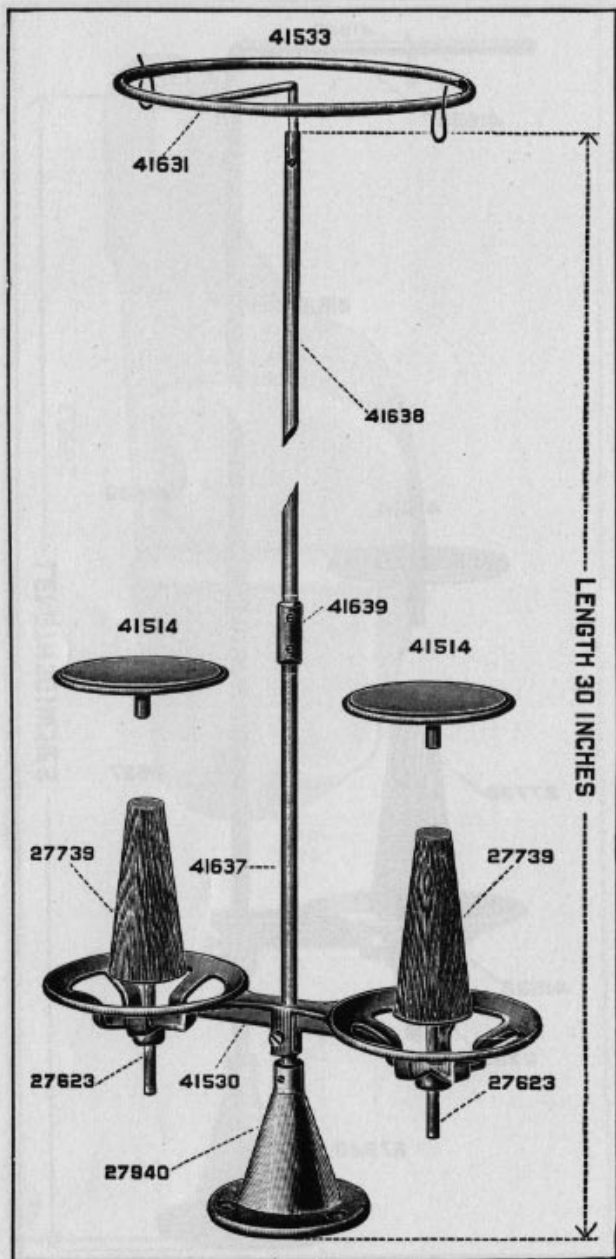


PLATE 3469—ONE-FOURTH SIZE

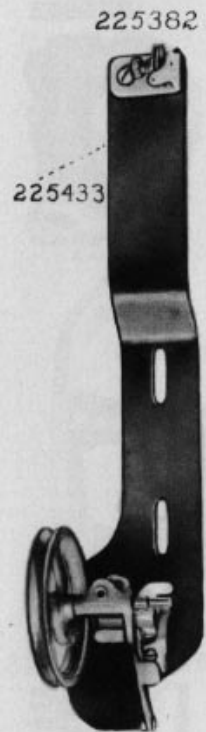


PLATE 3470—ONE-HALF SIZE

202473



225453

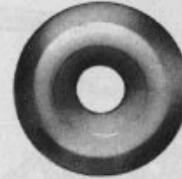


225381



PLATE 3471—FULL SIZE

2102



202407



201572



200082



202478



200299



225461



202104



225459



225460



200056



200380



225455



225454



225458



225444



225456



202277



225438





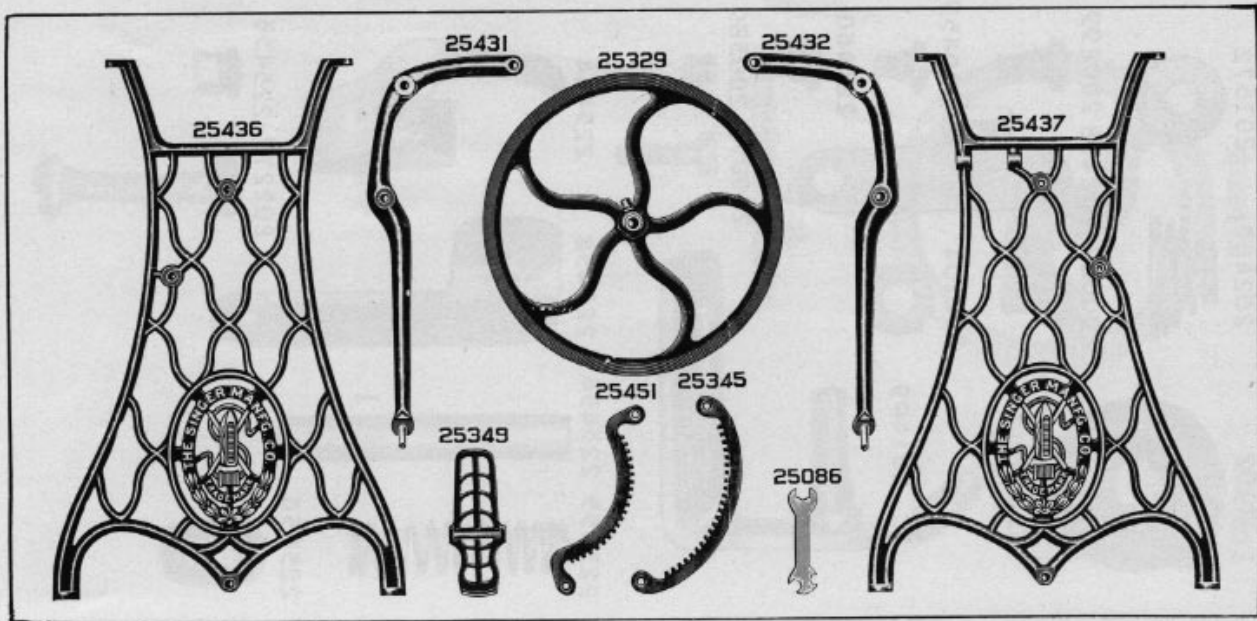


PLATE 3813—ONE-NINTH SIZE

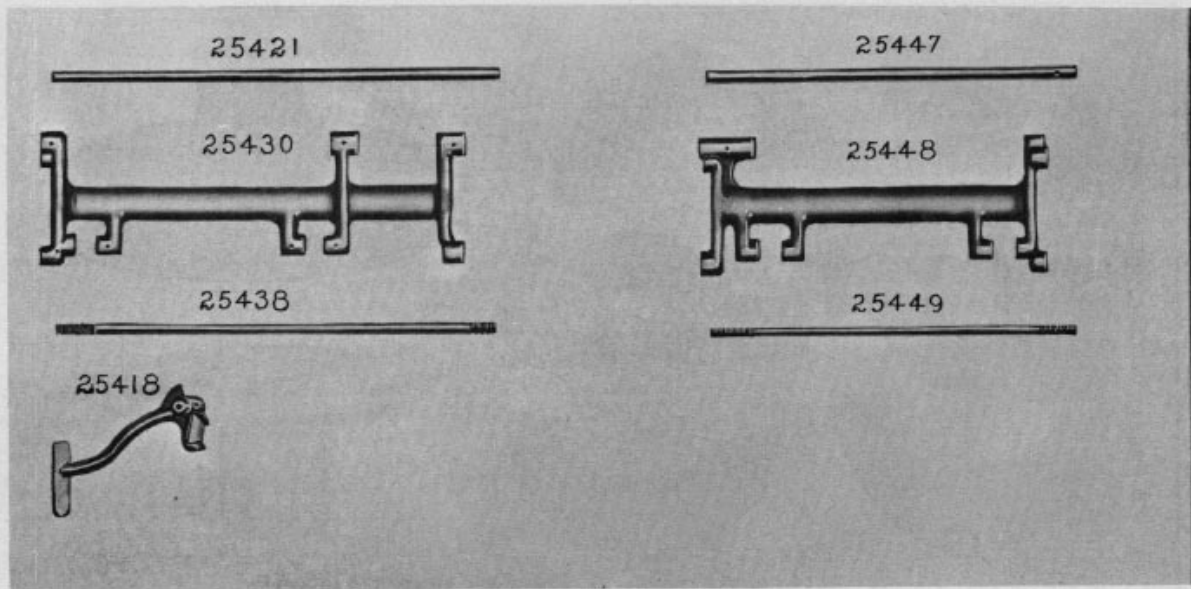


PLATE 3814—ONE-NINTH SIZE

PLATE 3815—ONE-HALF SIZE

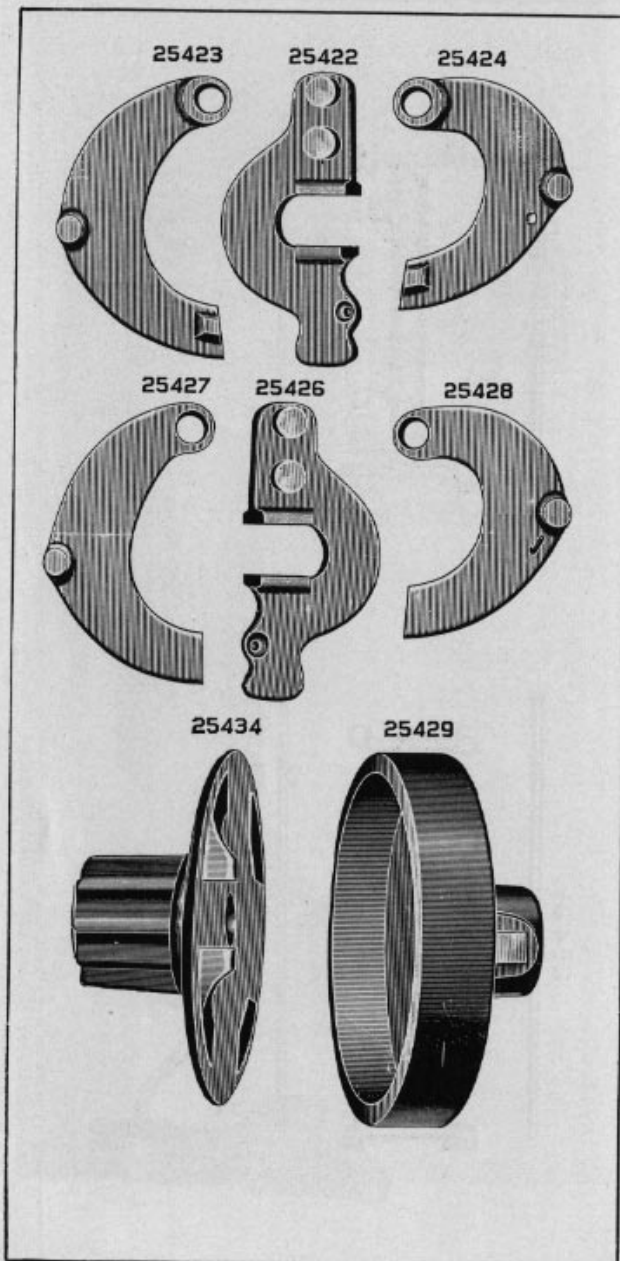


PLATE 3816—ONE-HALF SIZE

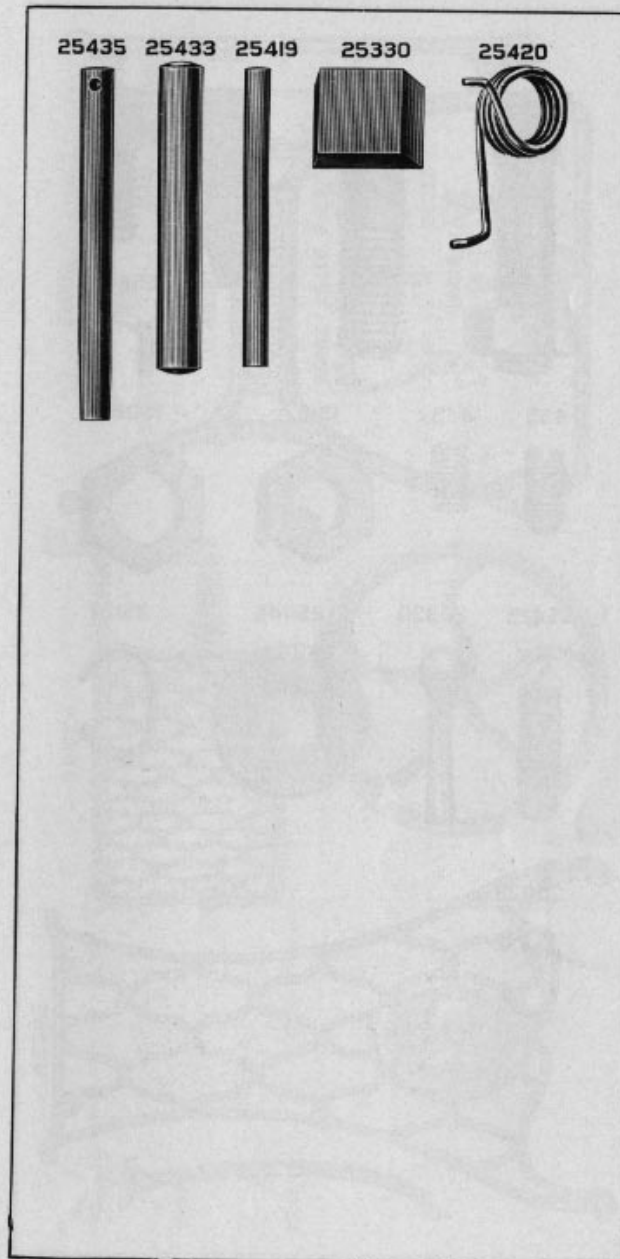
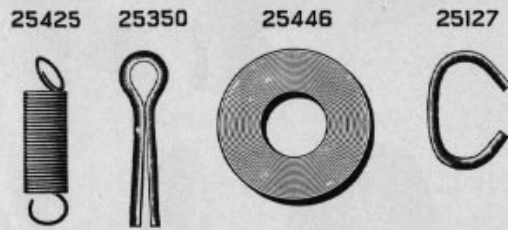
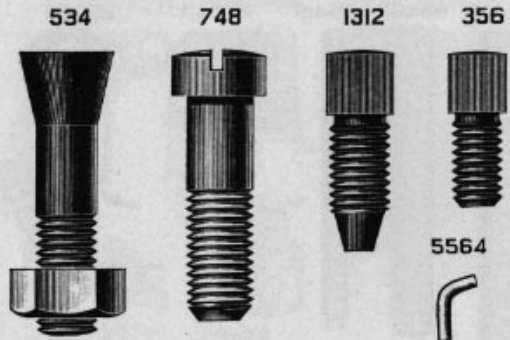




PLATE 3817—FULL SIZE



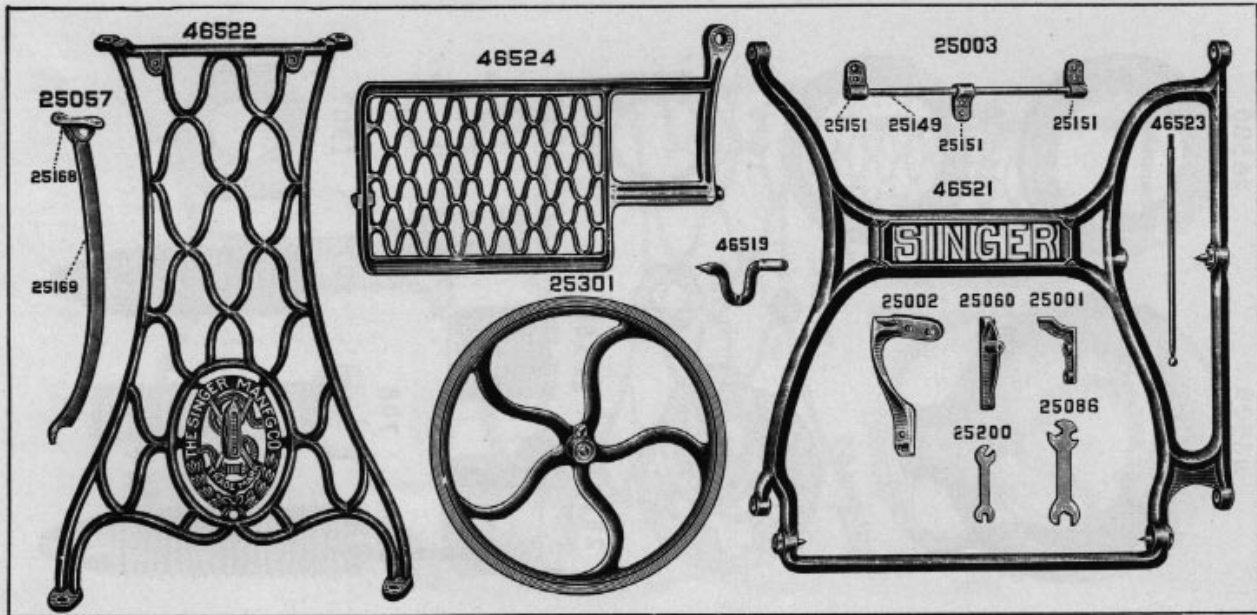


PLATE 3825—ONE-NINTH SIZE

PLATE 3826—FULL SIZE



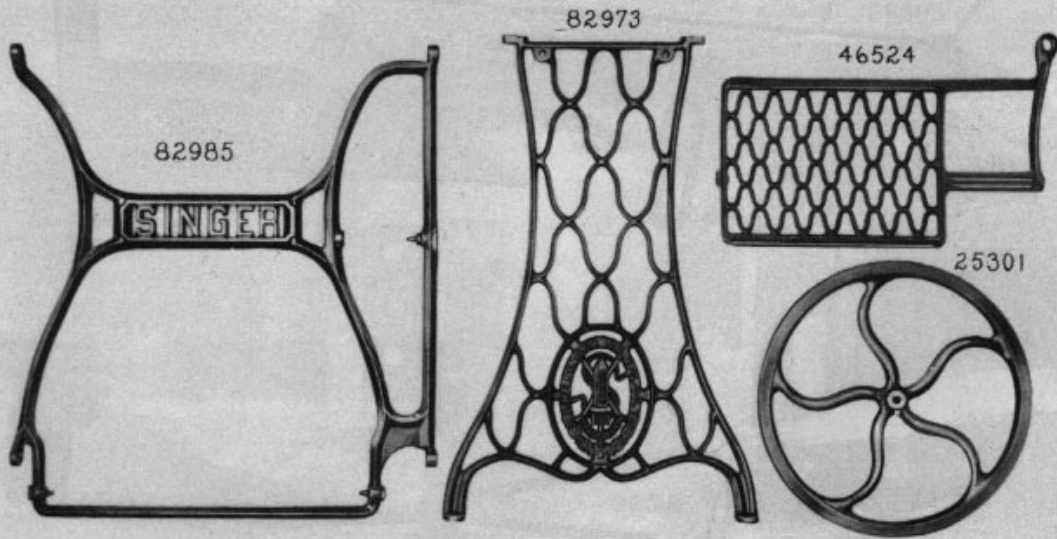


PLATE 5216—ONE-NINTH SIZE

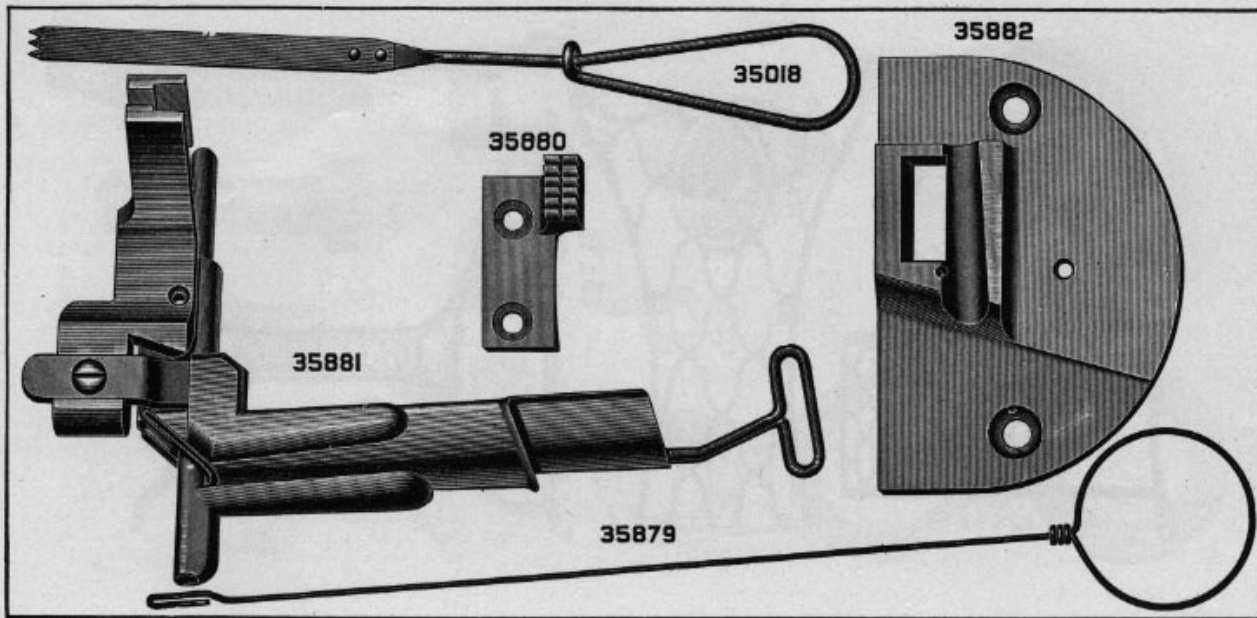


PLATE 5643-FULL SIZE

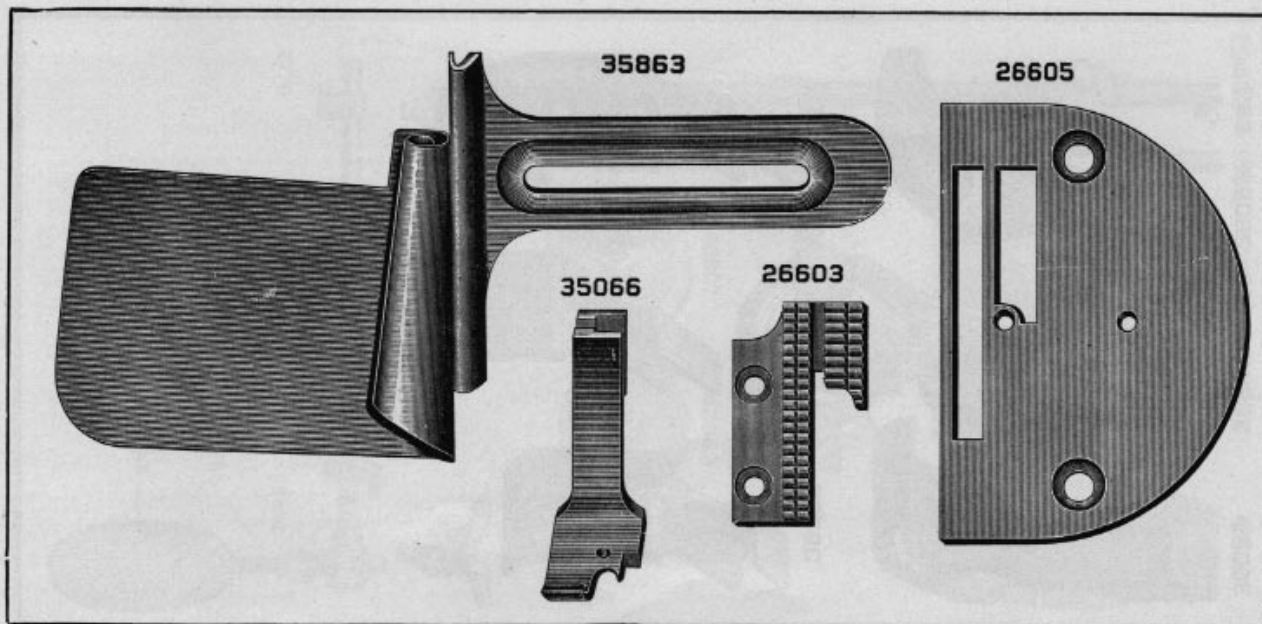


PLATE 5644-FULL SIZE

PLATE 5645—FULL SIZE

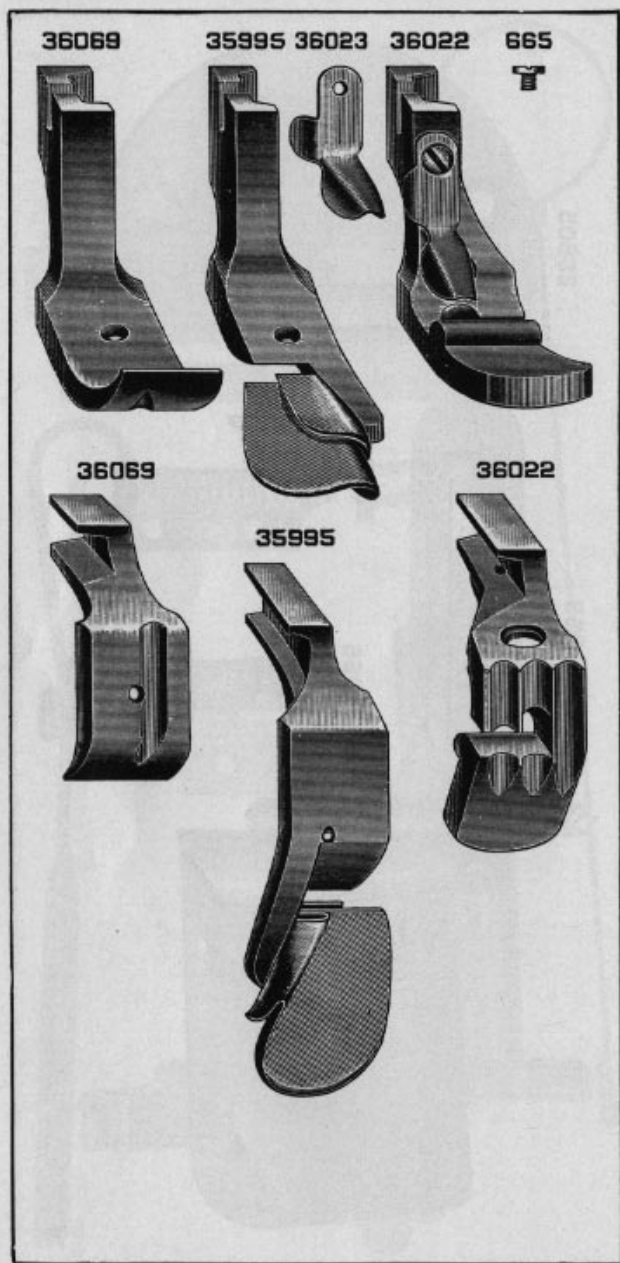


PLATE 5735—ONE-FOURTH SIZE

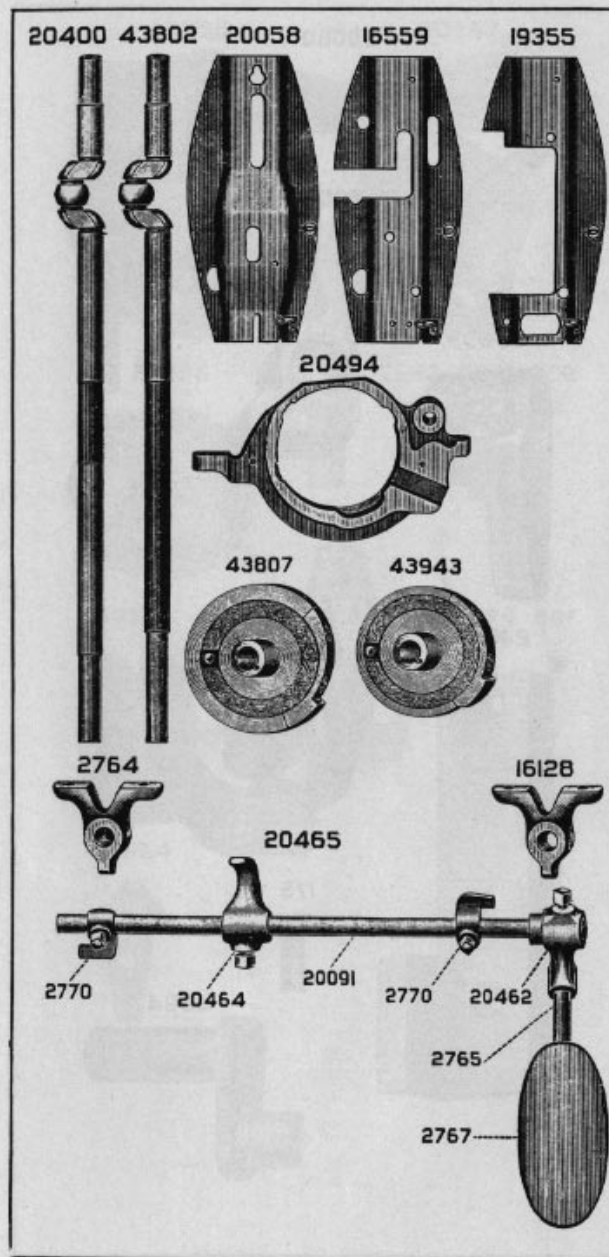




PLATE 5736—FULL SIZE

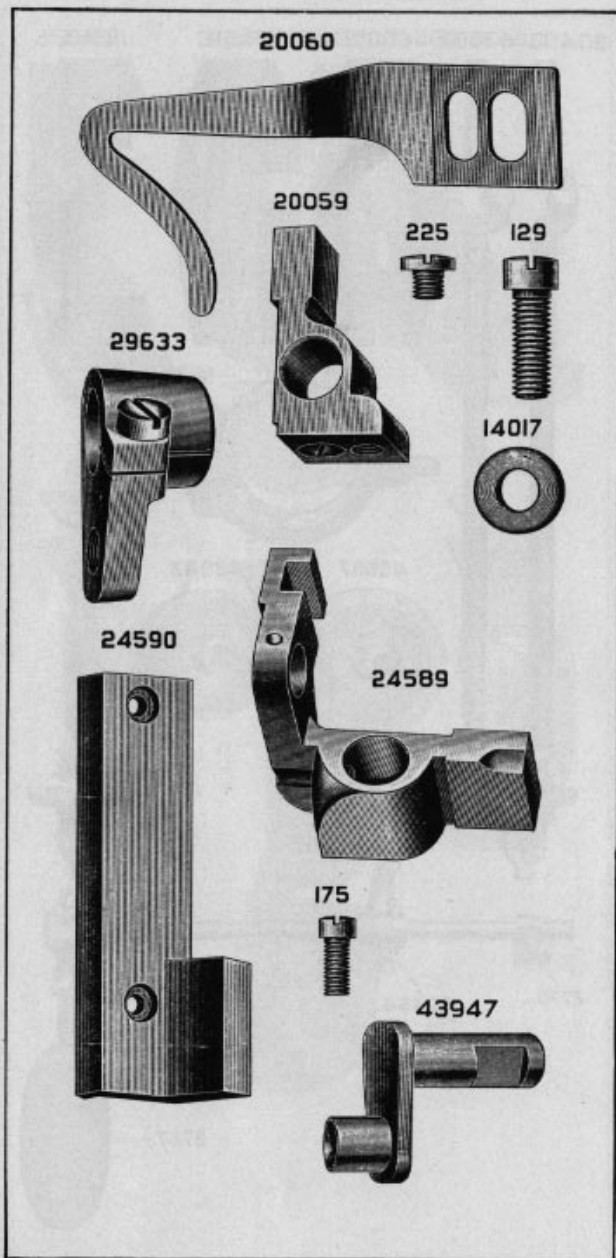


PLATE 5737—FULL SIZE

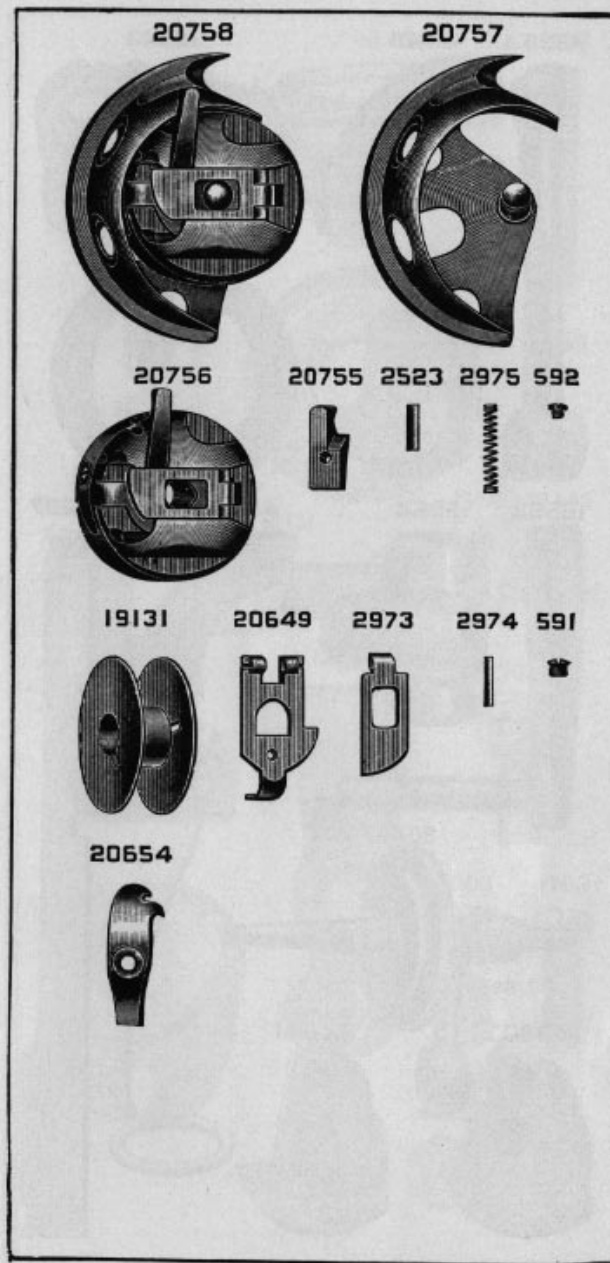


PLATE 5738—ONE-HALF SIZE

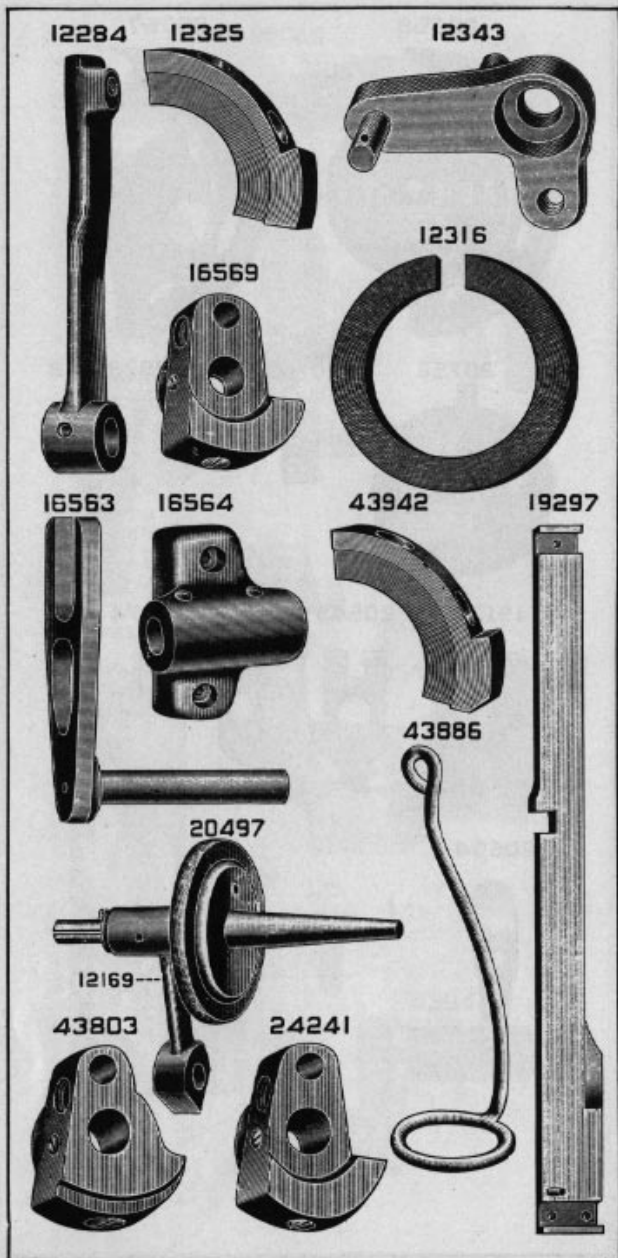


PLATE 5739—FULL SIZE

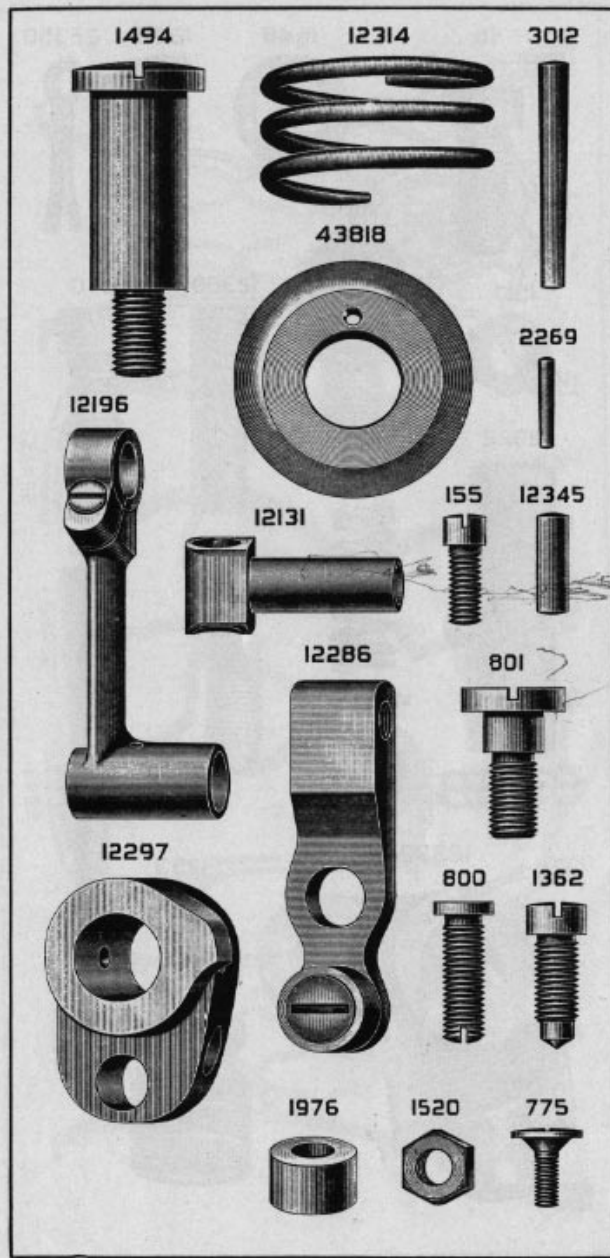




PLATE 5740—FULL SIZE

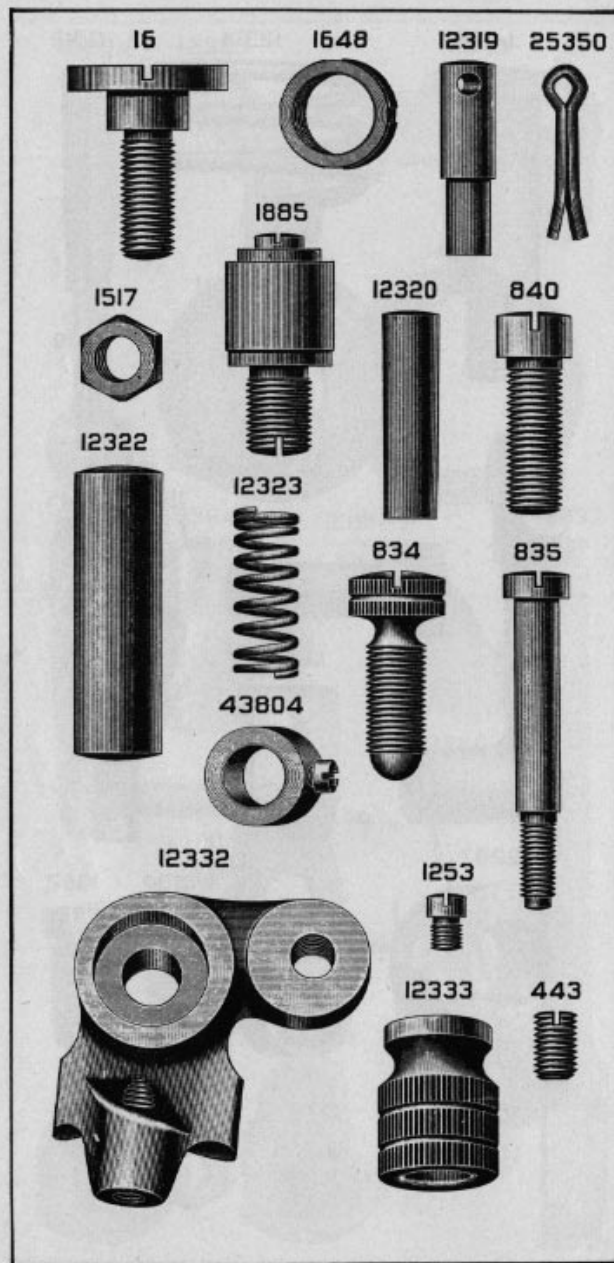


PLATE 5741—FULL SIZE

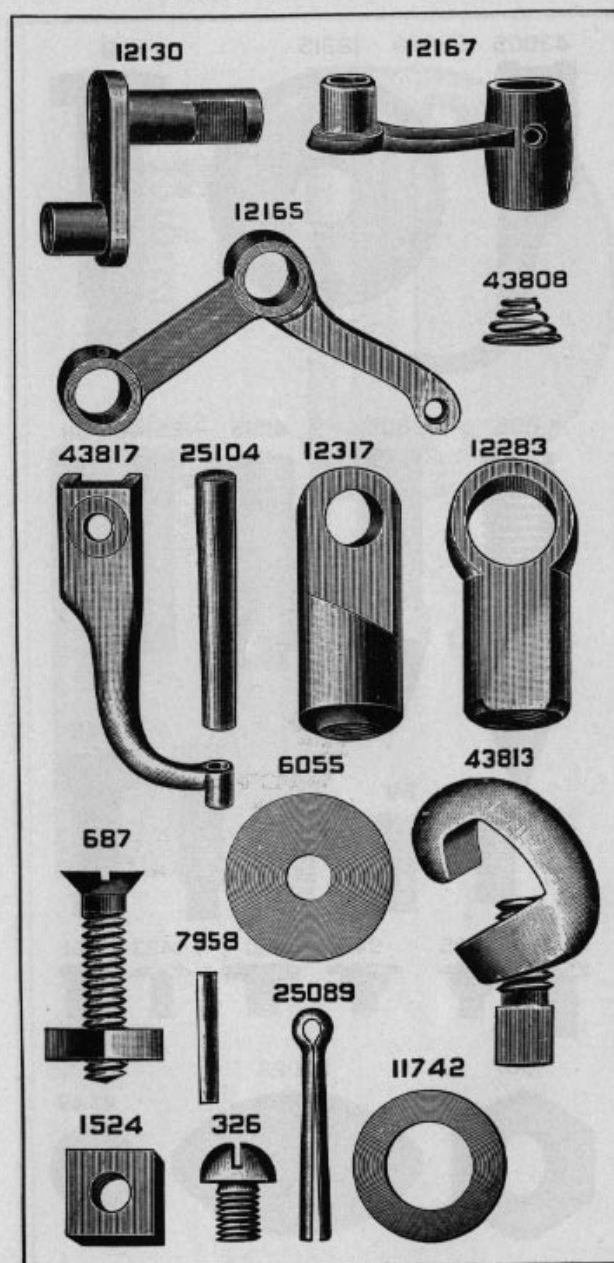


PLATE 5742—FULL SIZE

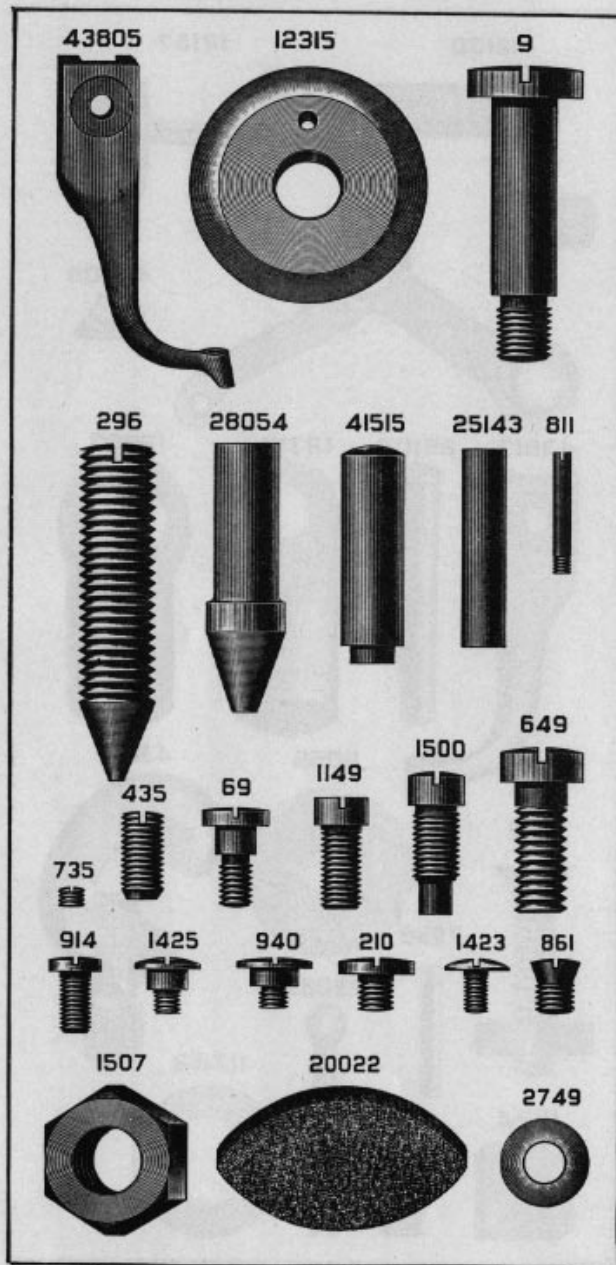


PLATE 5743—FULL SIZE

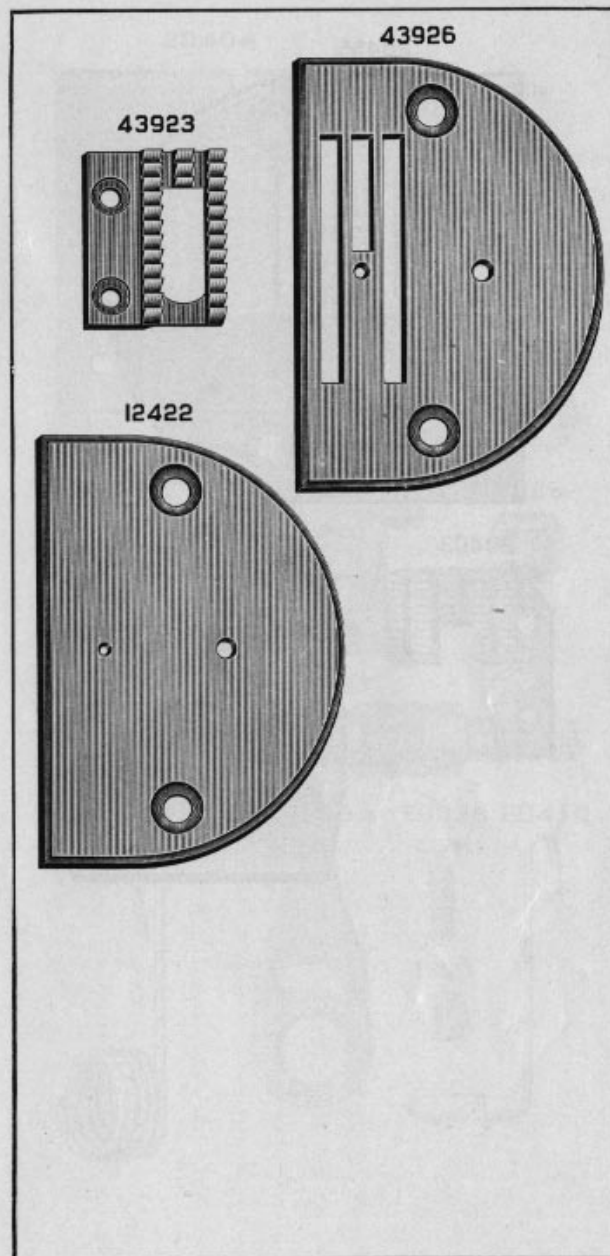


PLATE 5744—FULL SIZE

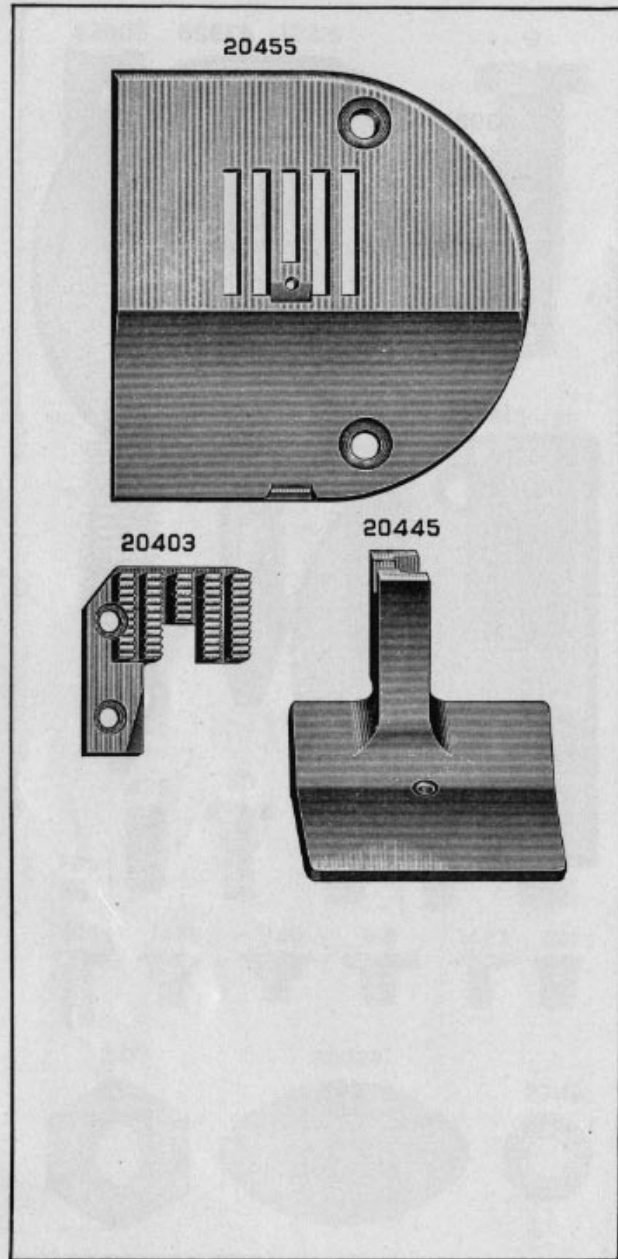


PLATE 5745—FULL SIZE

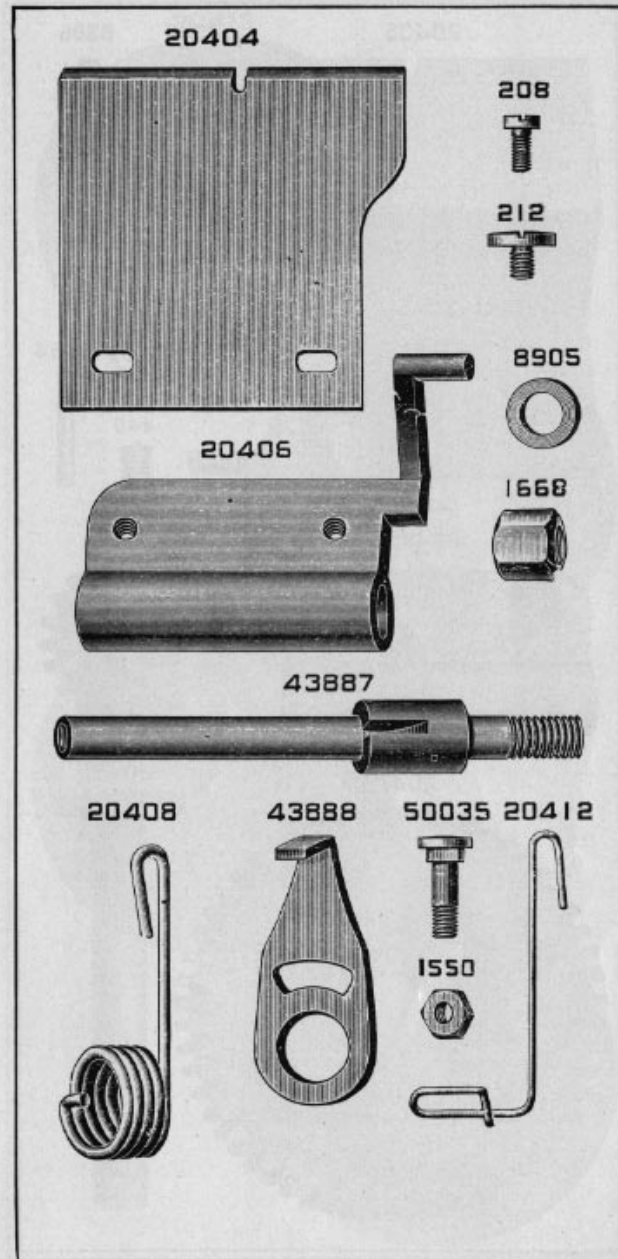


PLATE 5746—FULL SIZE

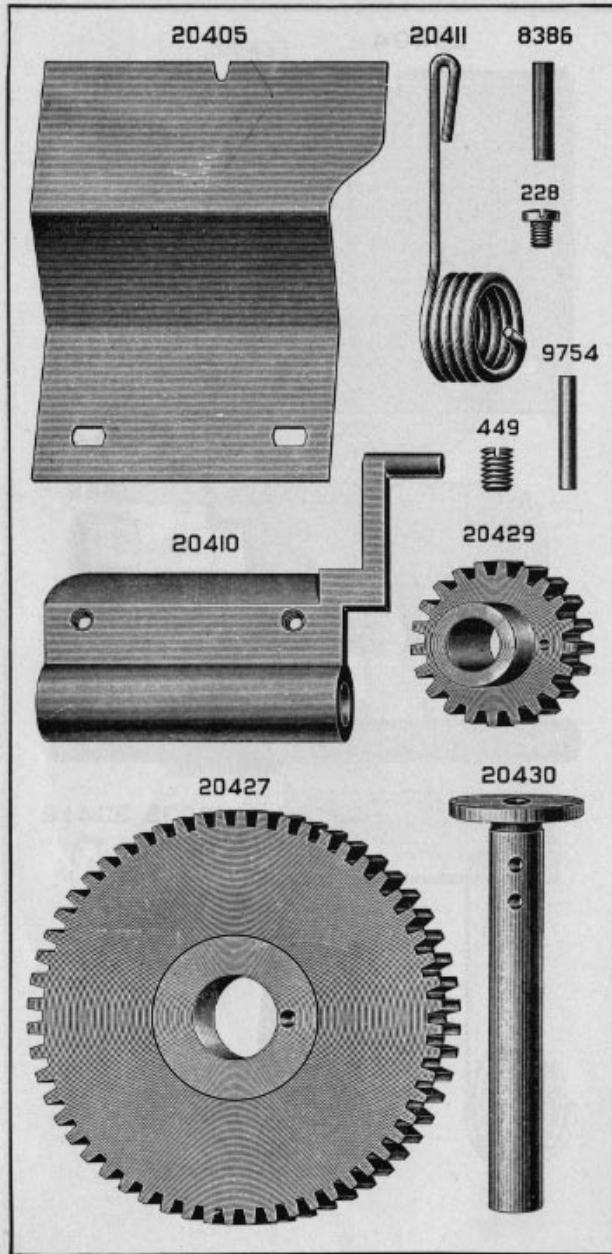


PLATE 5747—ONE-HALF SIZE

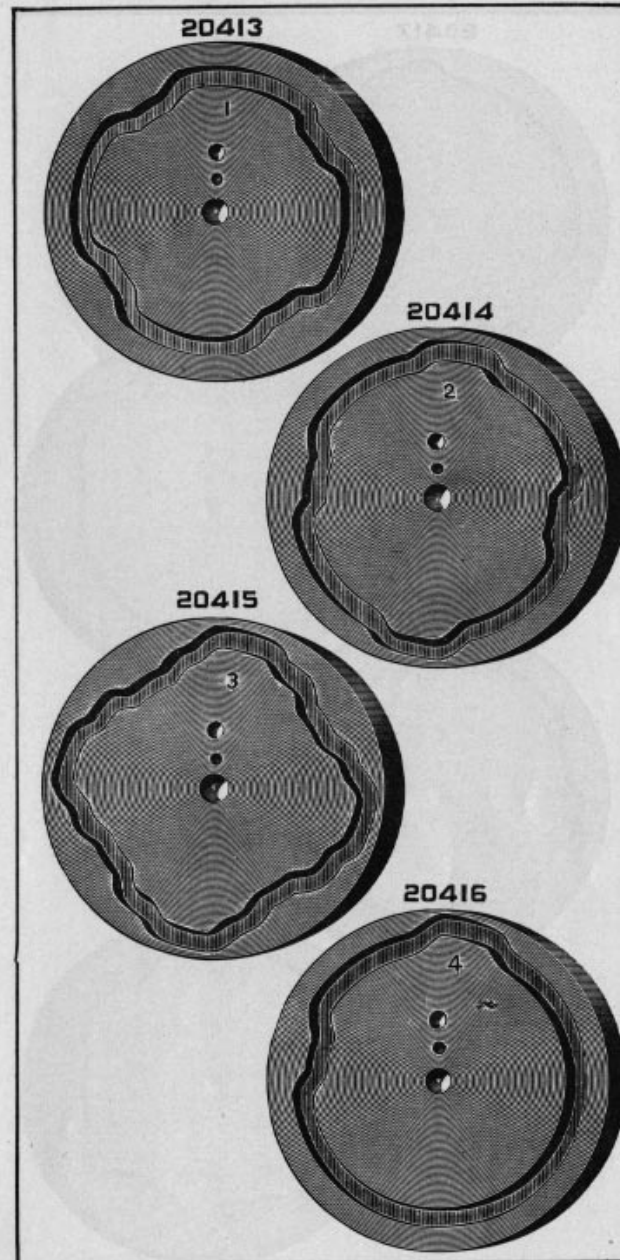




PLATE 5748—ONE-HALF SIZE

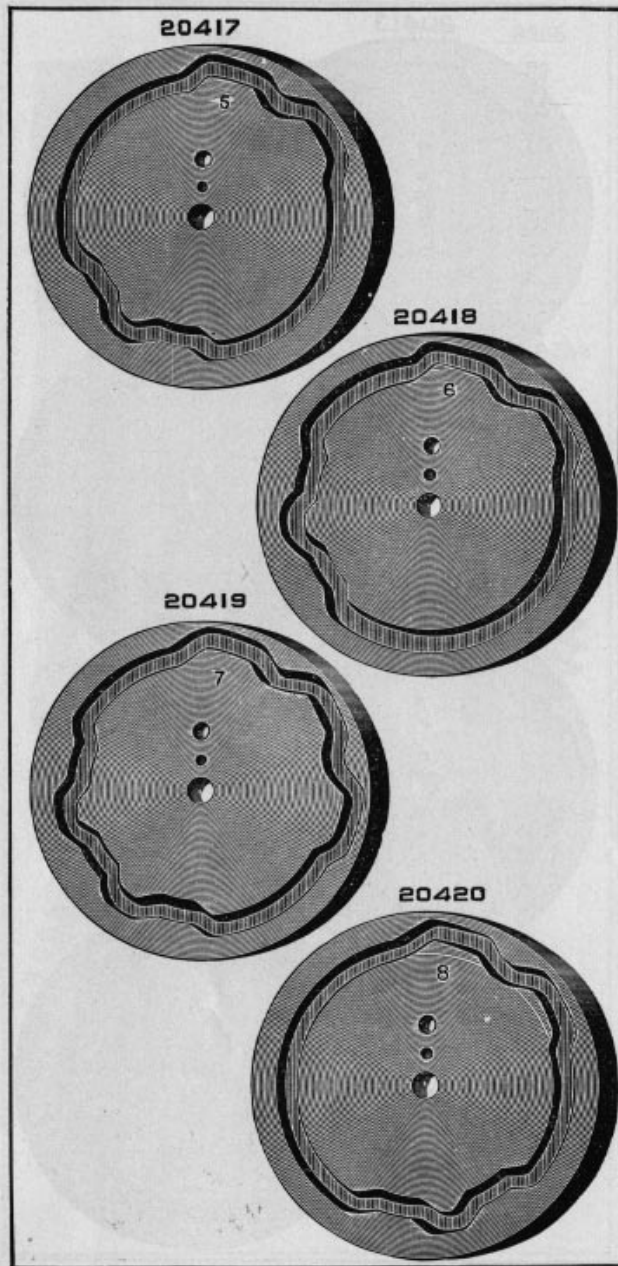


PLATE 5749—ONE-HALF SIZE

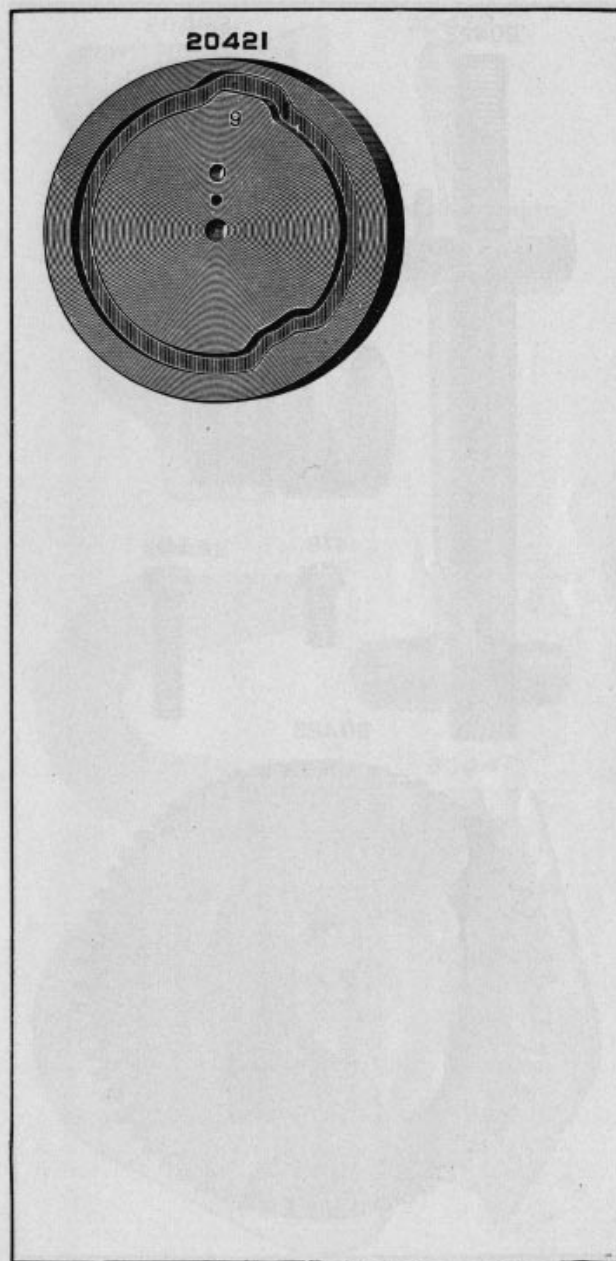


PLATE 5750—FULL SIZE

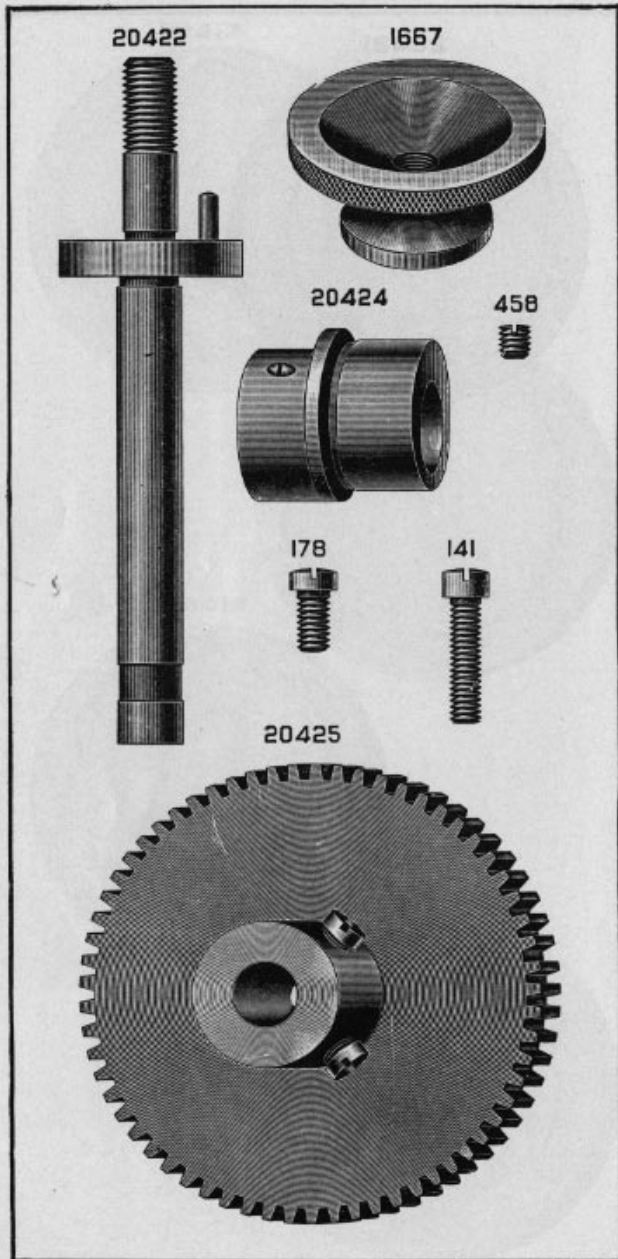


PLATE 5751—ONE-HALF SIZE

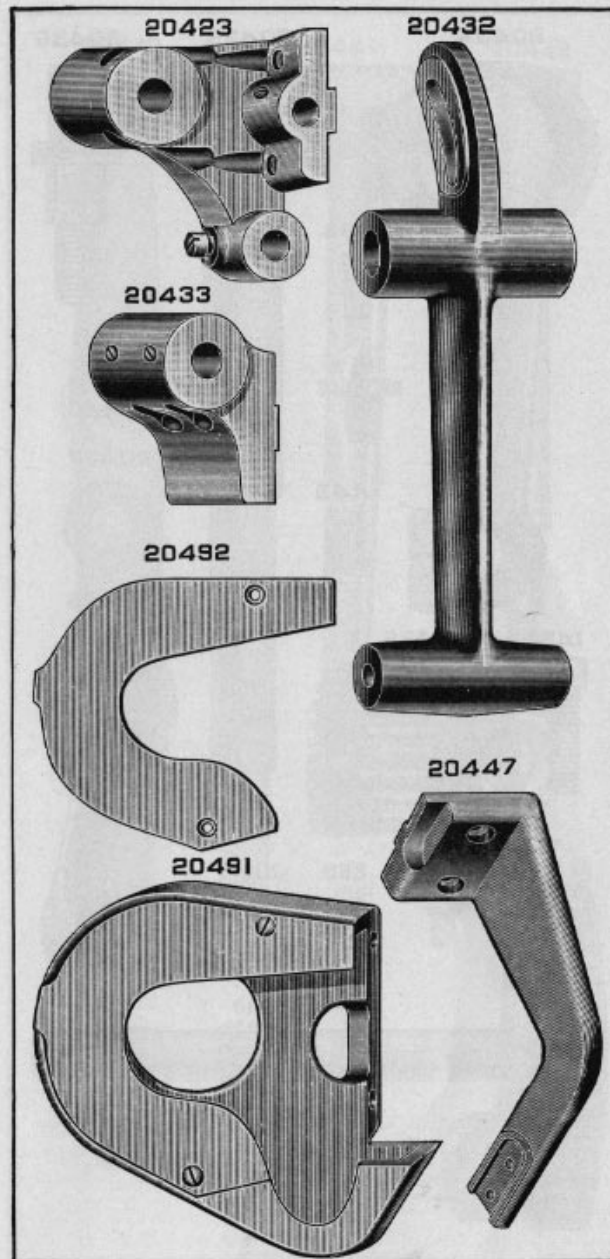


PLATE 5752—FULL SIZE

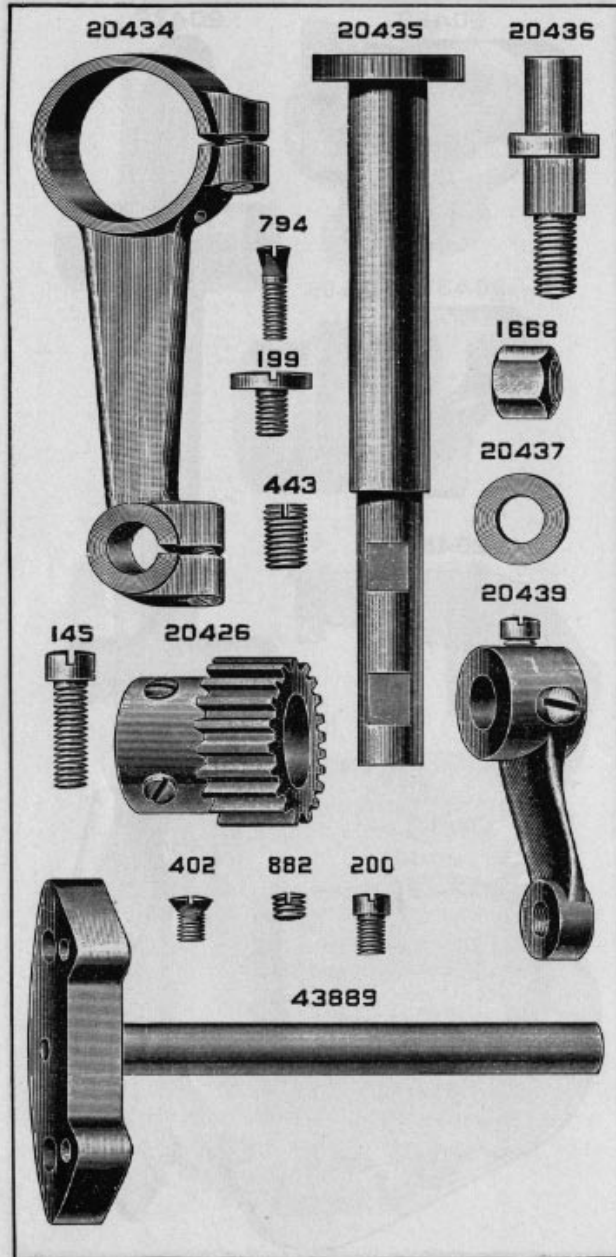


PLATE 5753—FULL SIZE

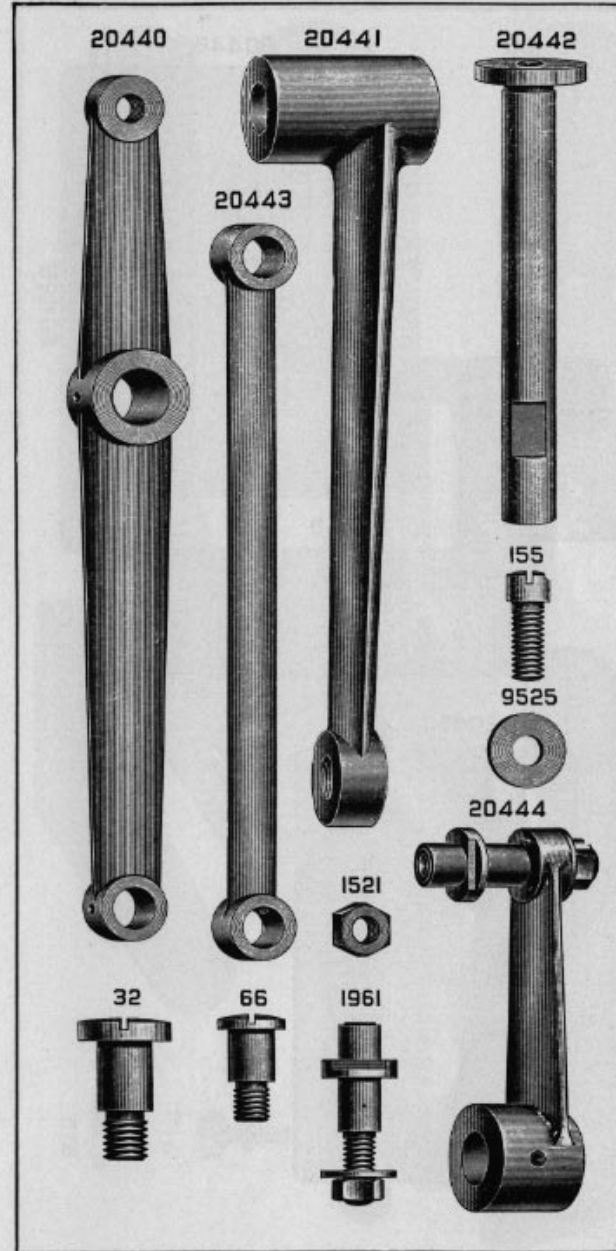
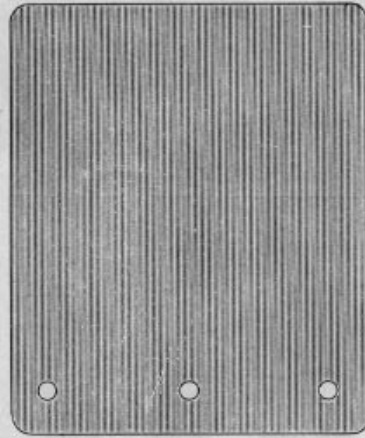


PLATE 5754—FULL SIZE

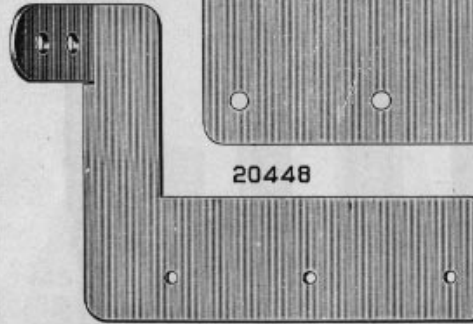
185



20446

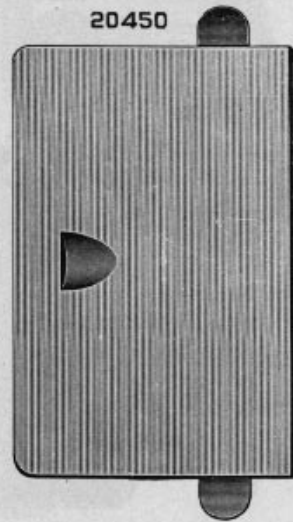


241



20448

20450





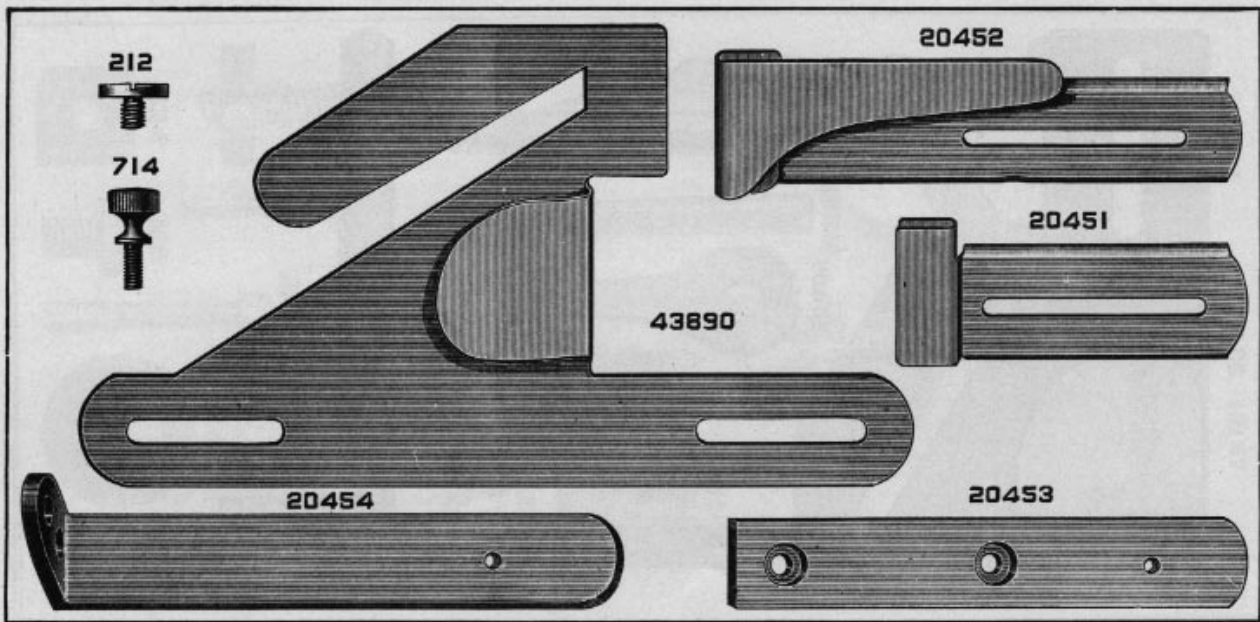


PLATE 5765—FULL SIZE

PLATE 5756—FULL SIZE

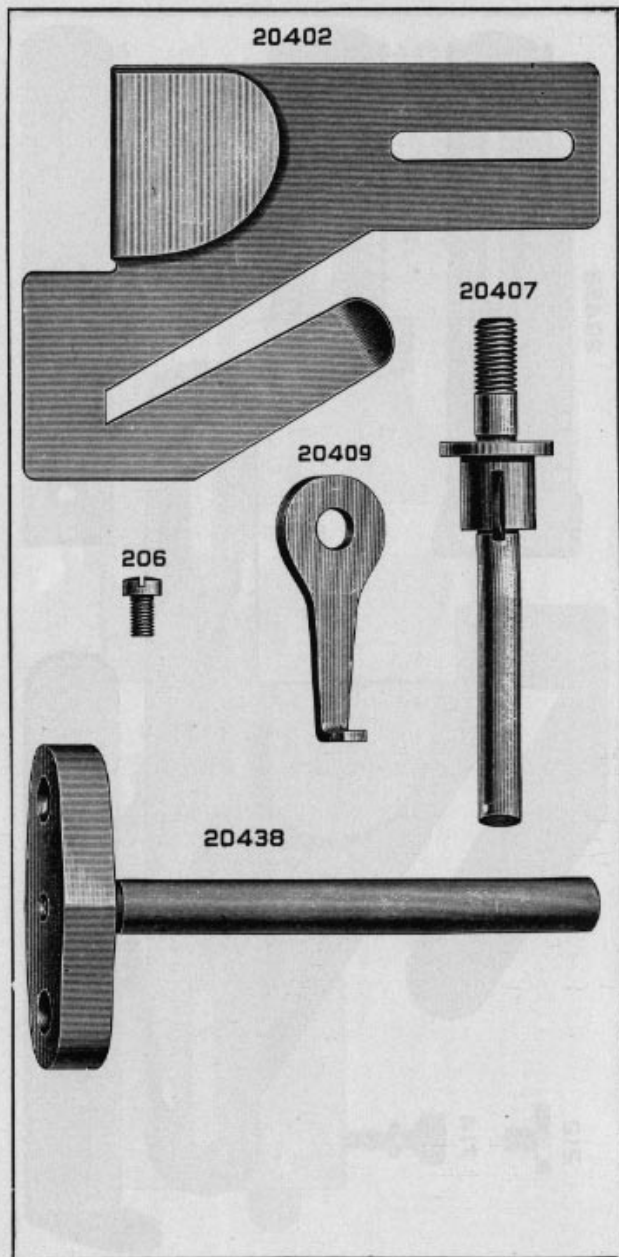
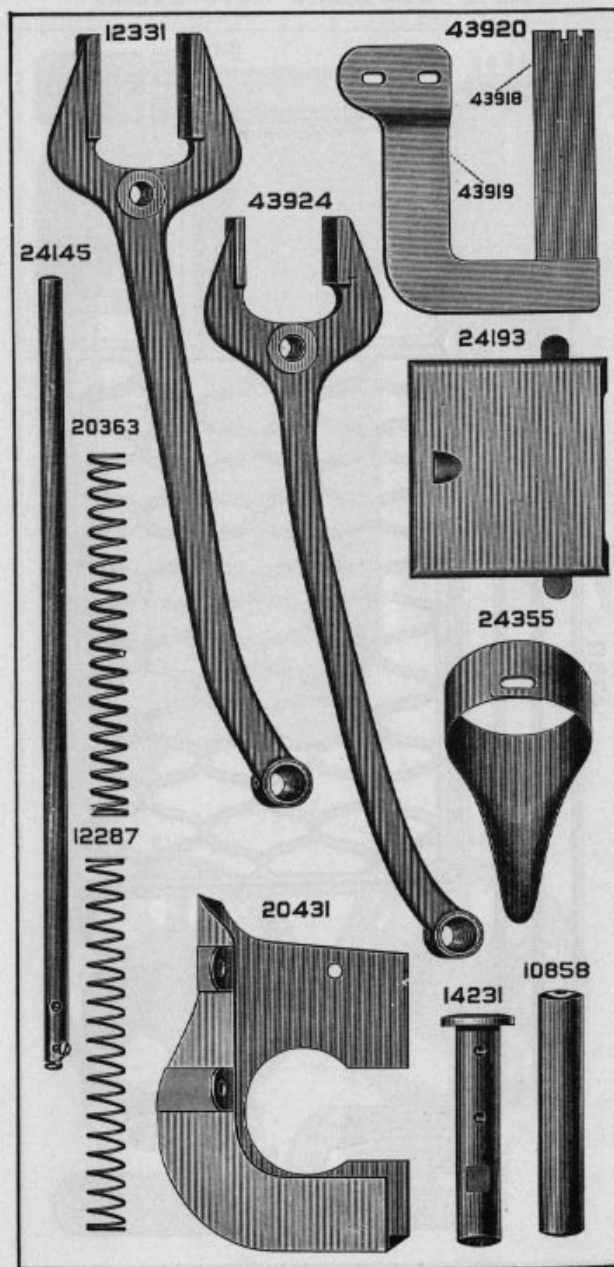


PLATE 5757—ONE-HALF SIZE



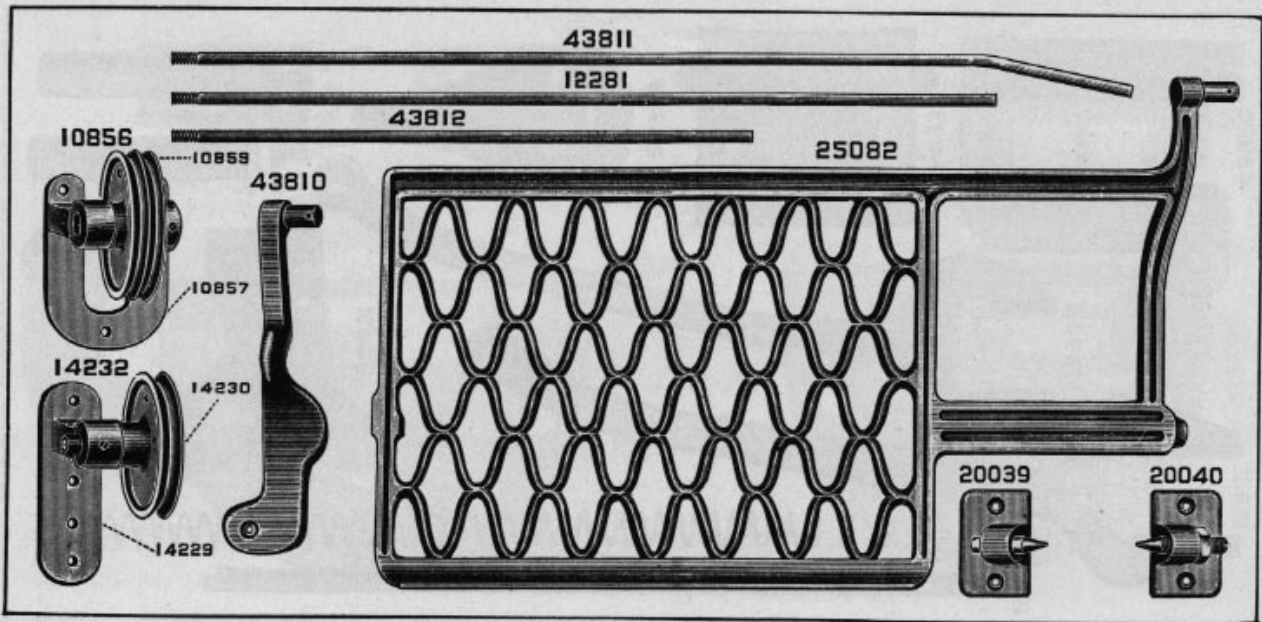
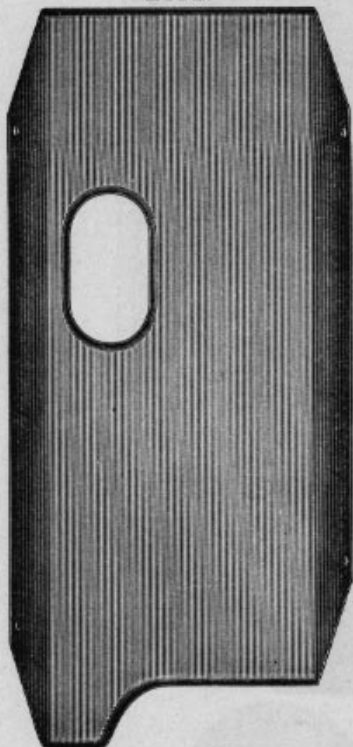


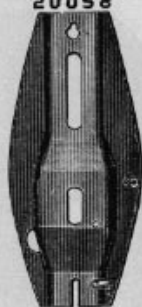
PLATE 5760—ONE-FOURTH SIZE

PLATE 5761—ONE-FOURTH SIZE

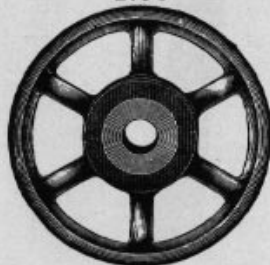
20021



20058



2135



4370

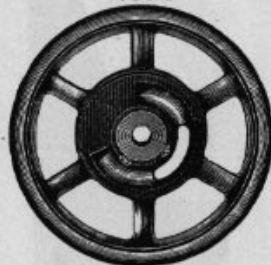


PLATE 5762—ONE-FOURTH SIZE

20467

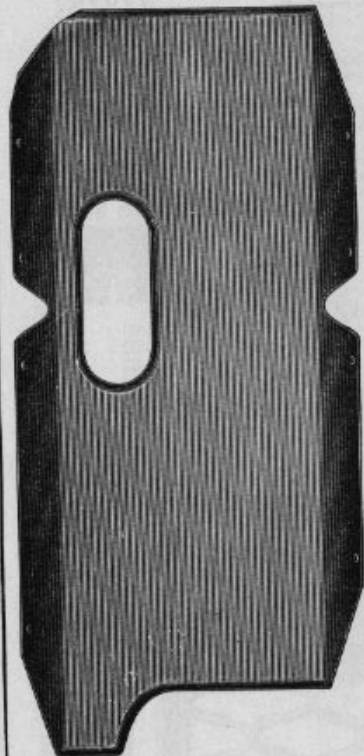
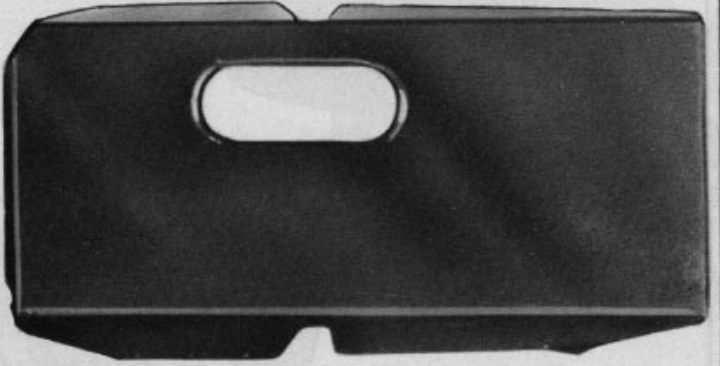


PLATE 5763—ONE-FOURTH SIZE



43940

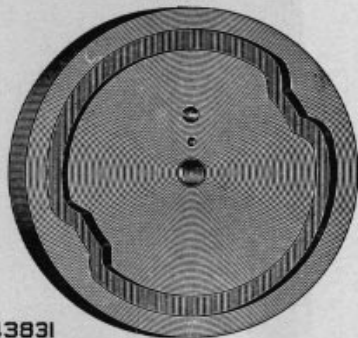


126356

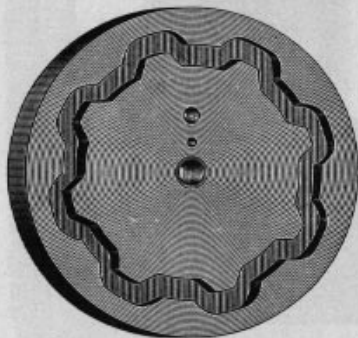


PLATE 5784—ONE-HALF SIZE

43830



43831



43832



43833



PLATE 5785—ONE-HALF SIZE

43834



PLATE 5804—ONE-HALF SIZE

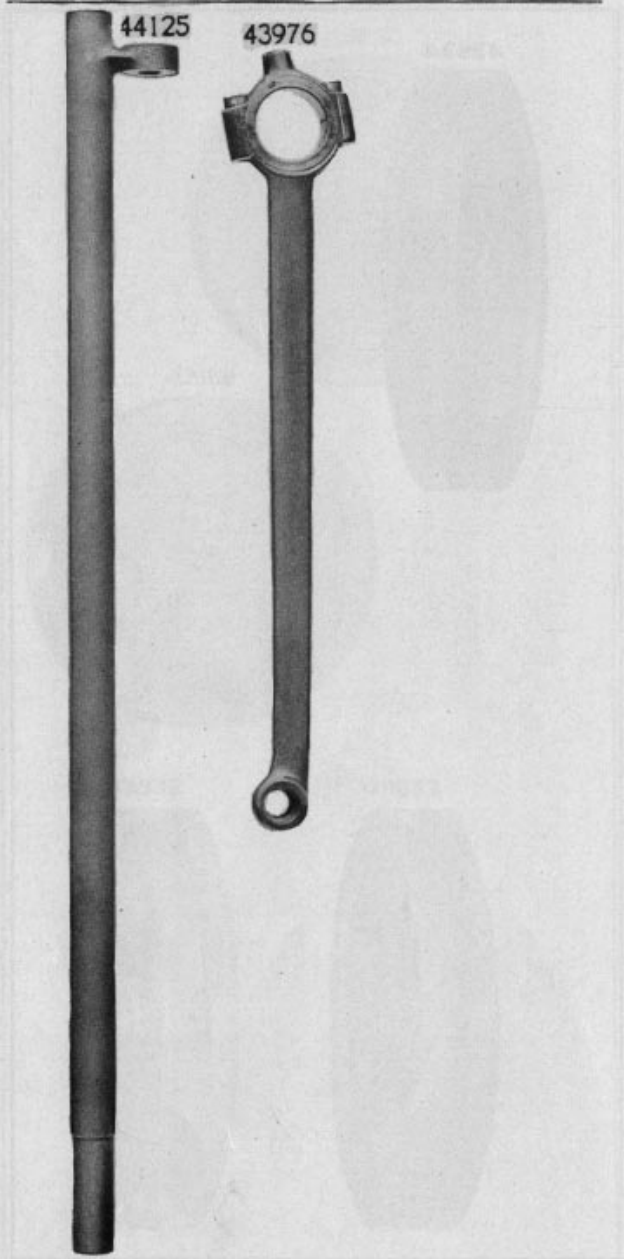
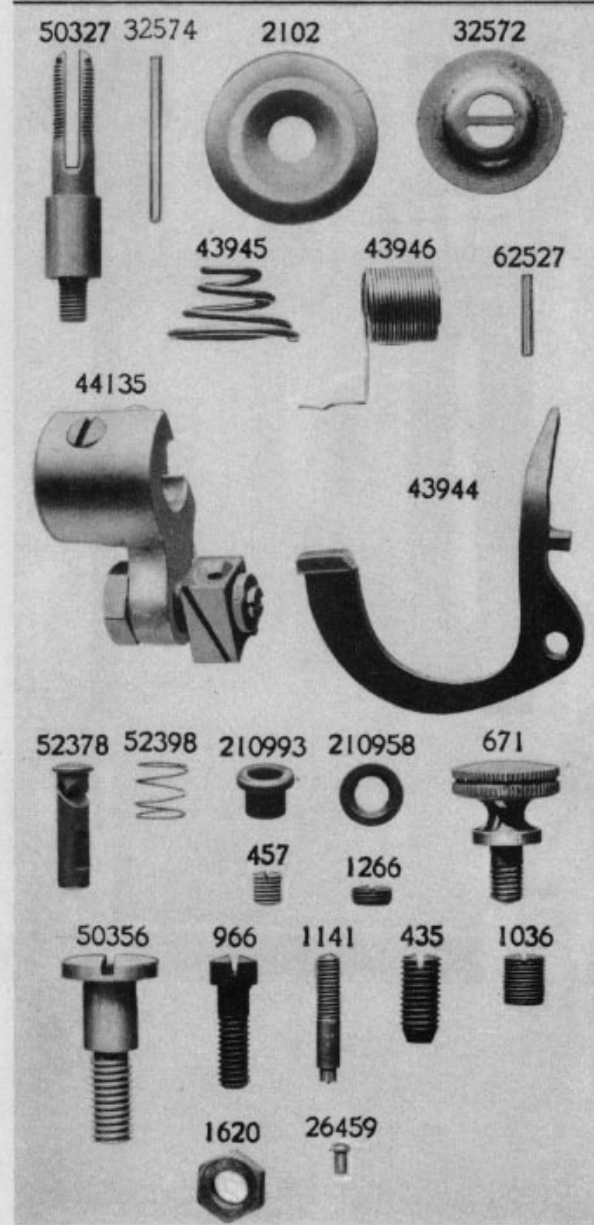


PLATE 5806—FULL SIZE





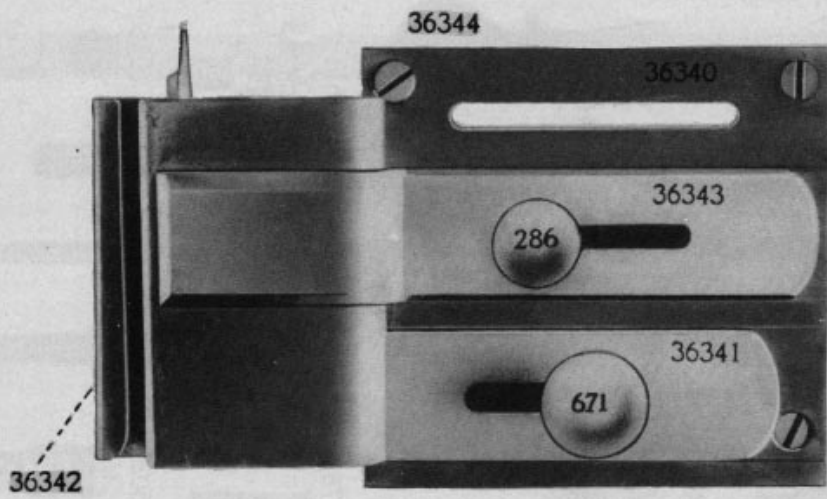


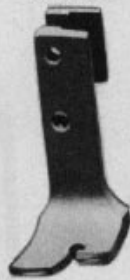
PLATE 5807—FULL SIZE

PLATE 5808—FULL SIZE

36623



36622



36576



50202



36700



36182

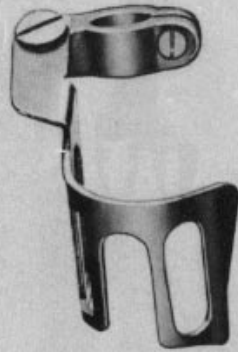


36183



PLATE 5809—FULL SIZE

36821



36818



36819



36820



50316



196



50302



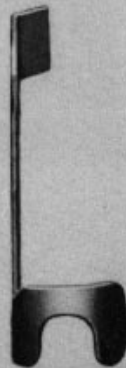
236



120498



120496



120497



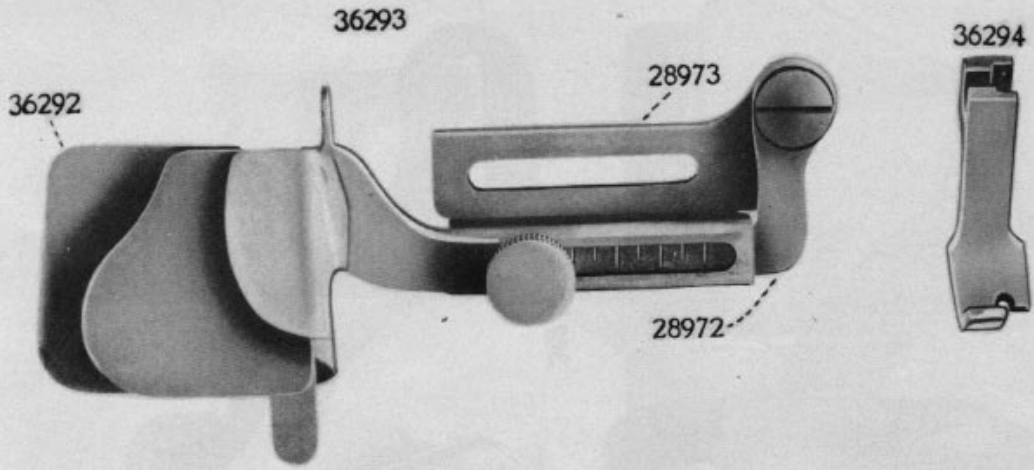
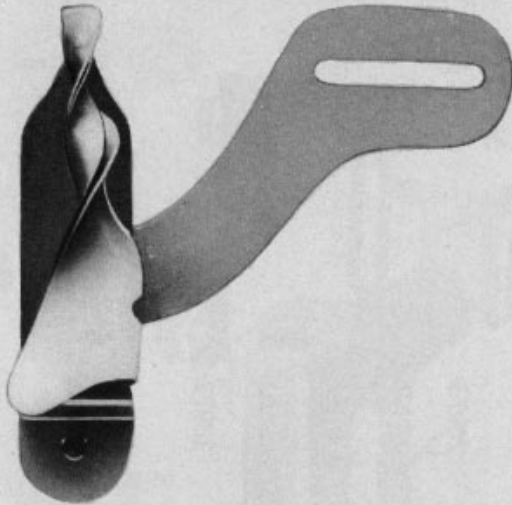


PLATE 5810—FULL SIZE

PLATE 5811—FULL SIZE

---

36521



36712

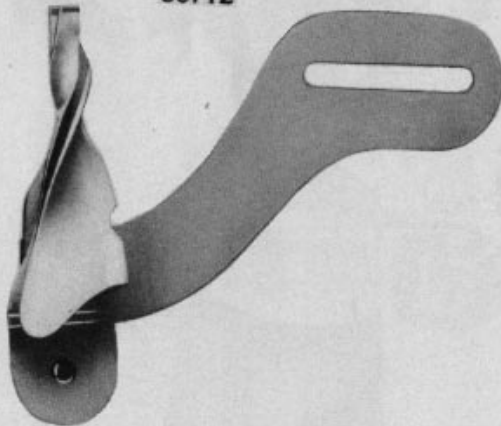
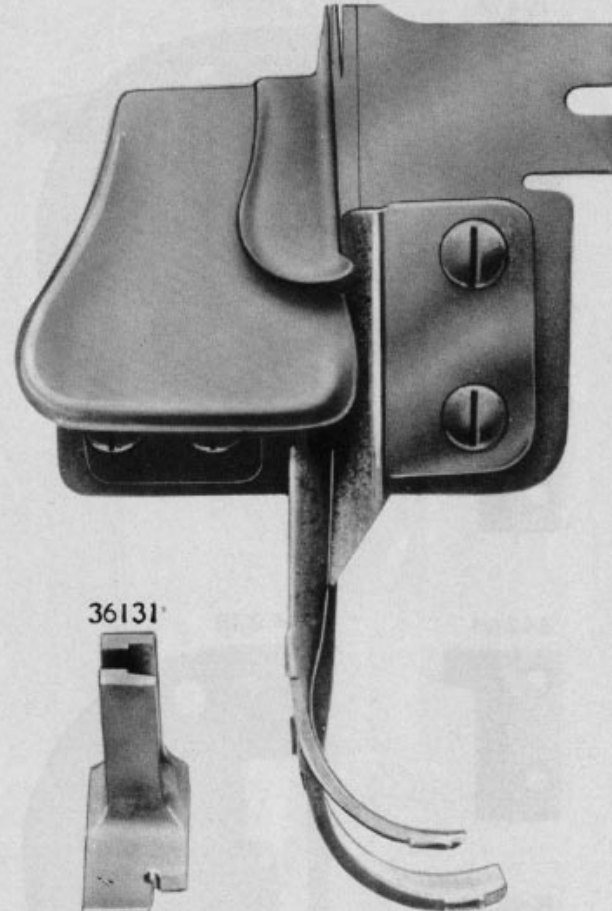


PLATE 5812—FULL SIZE

---

36129



36131

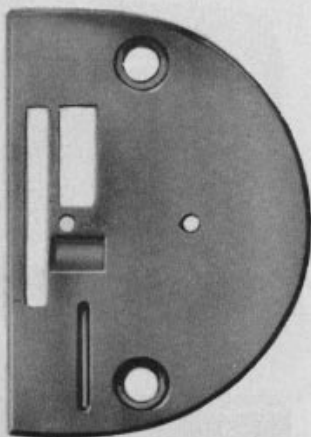


PLATE 5813—FULL SIZE

19474



36906



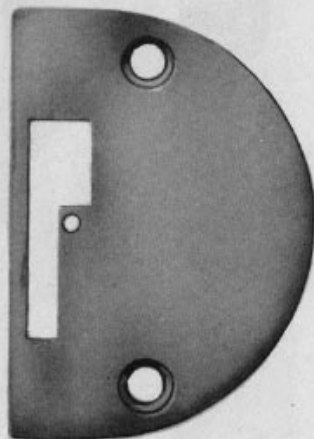
44252



44253



44255

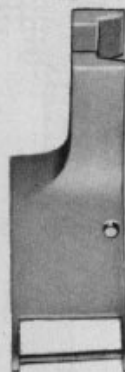


44254



PLATE 5837—FULL SIZE

12348



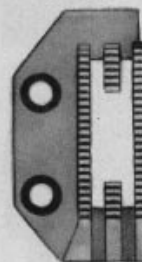
12311



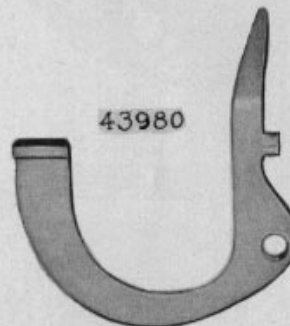
24489



44156



43980



1054



5968



24414



578

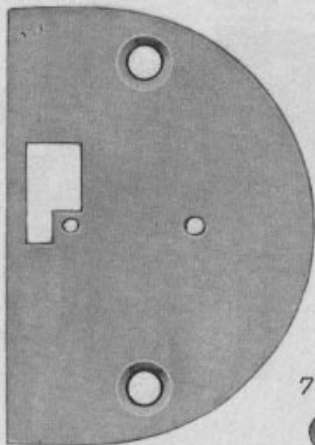


21202

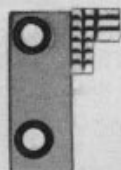


PLATE 5838—FULL SIZE

120126



120124



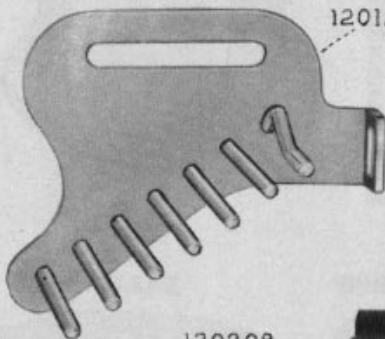
120125



7806



120123

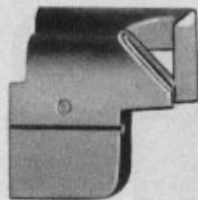


120122

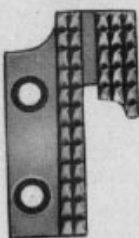
120121



120120



120001



120208





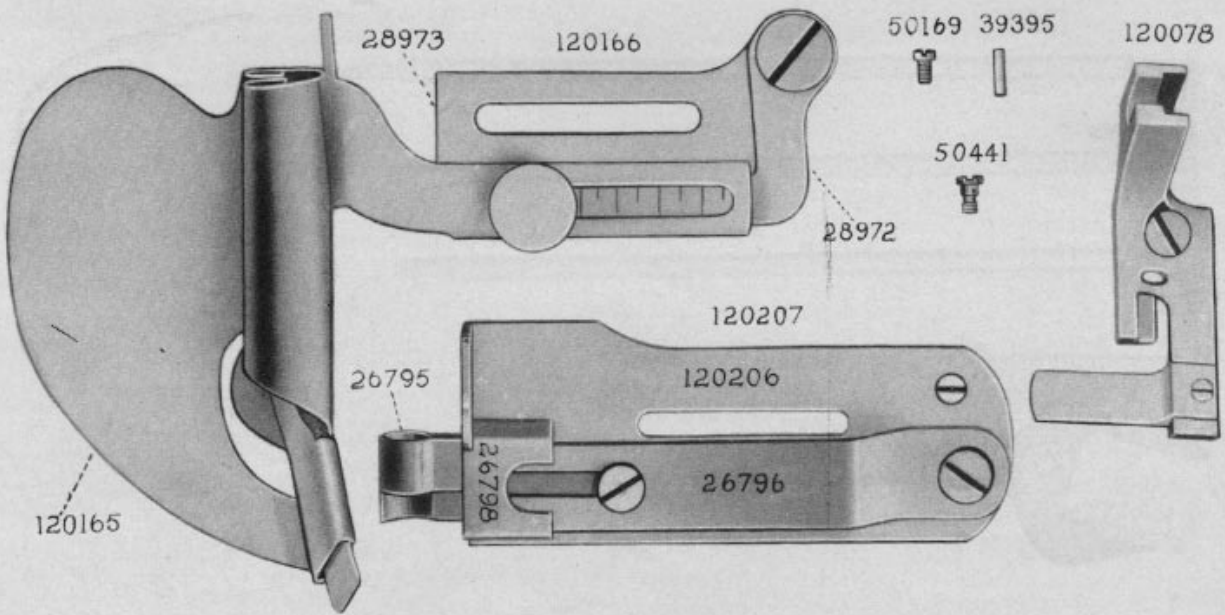
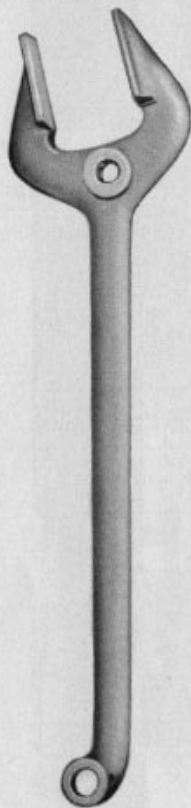


PLATE 5839—FULL SIZE



PLATE 5840—ONE-HALF SIZE

44003



44009



PLATE 5841—ONE-HALF SIZE

46659



16568



19265



24431



10875



27638



PLATE 5842—FULL SIZE

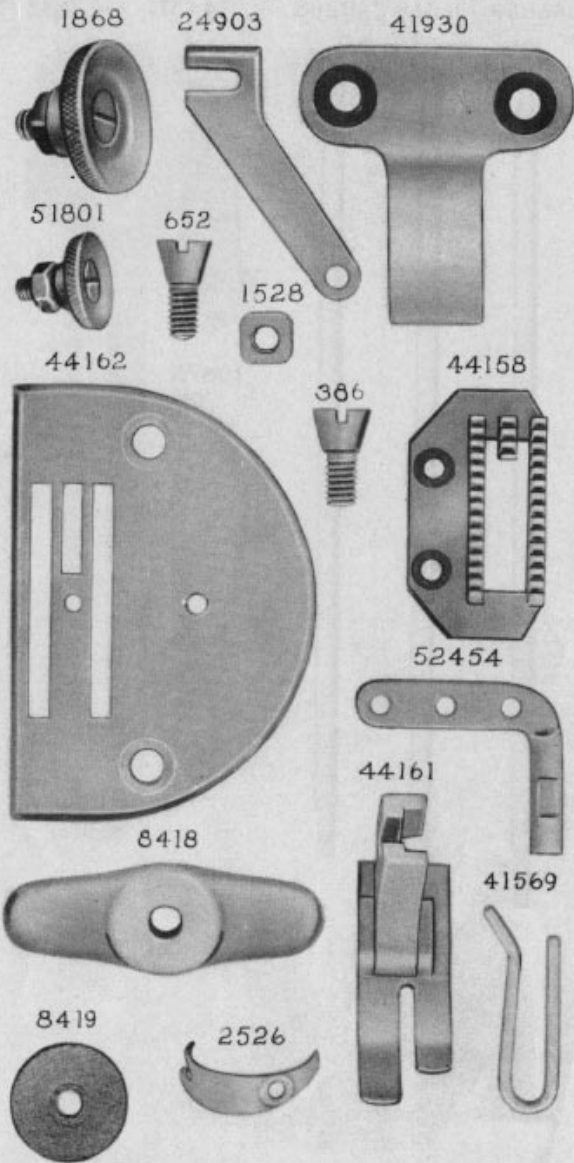


PLATE 5843—FULL SIZE

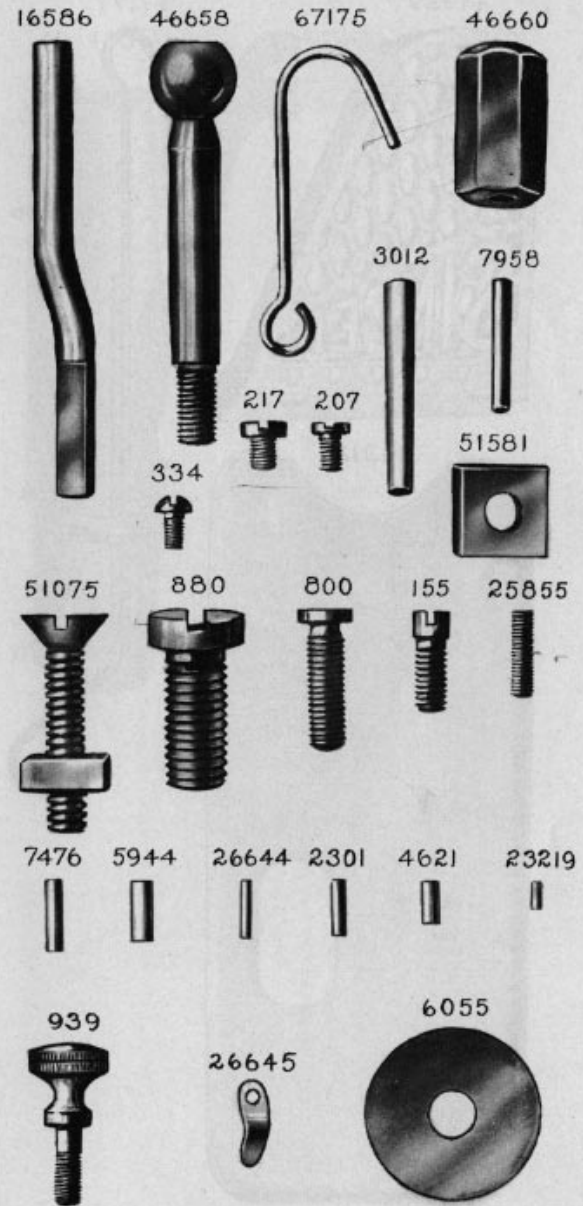
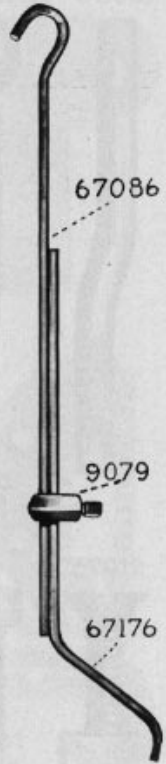


PLATE 5844—ONE-FOURTH SIZE

41929



67177



67086

9079

67176

44212



PLATE 5845—ONE-HALF SIZE

120191

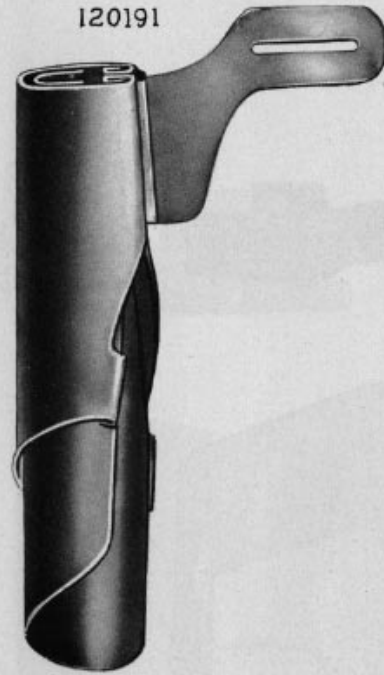


PLATE 5846—FULL SIZE

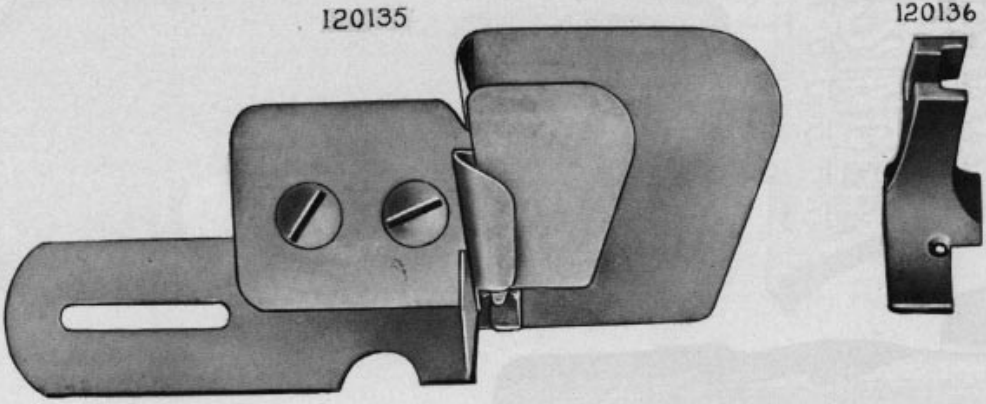
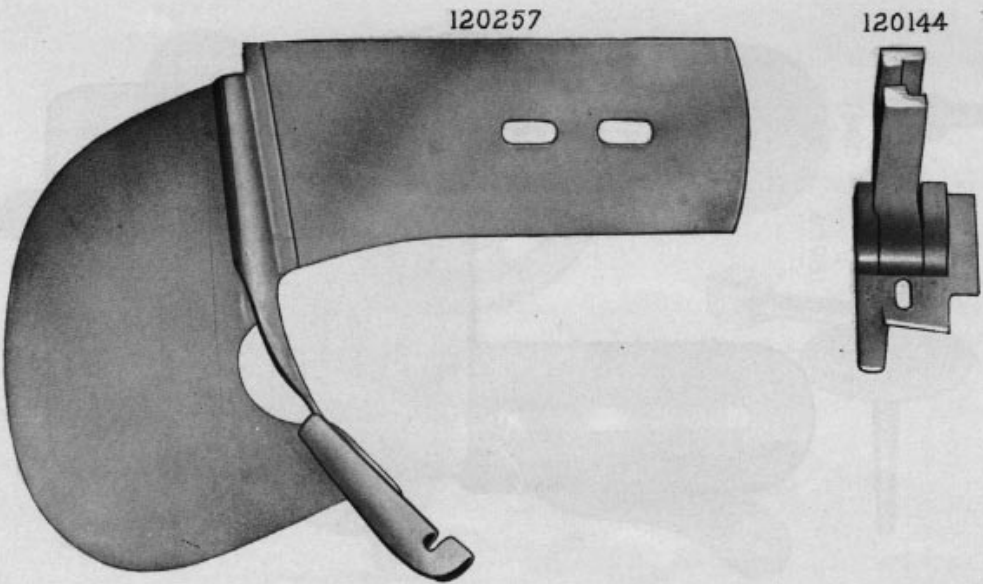
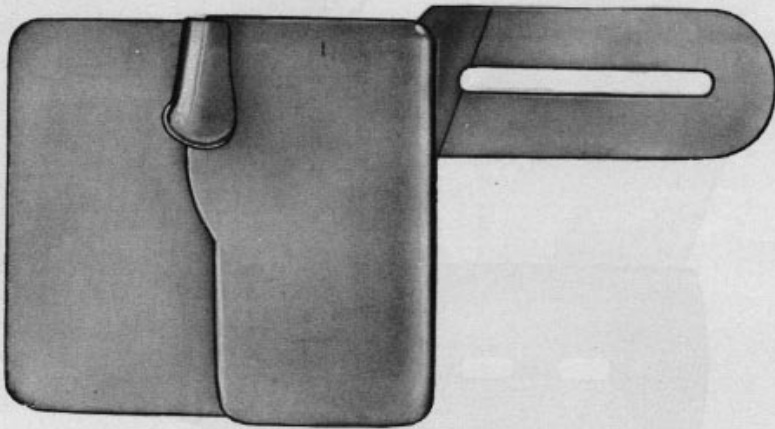


PLATE 5847—FULL SIZE



120197



---

PLATE 5848—FULL SIZE



PLATE 6119—ONE-HALF SIZE

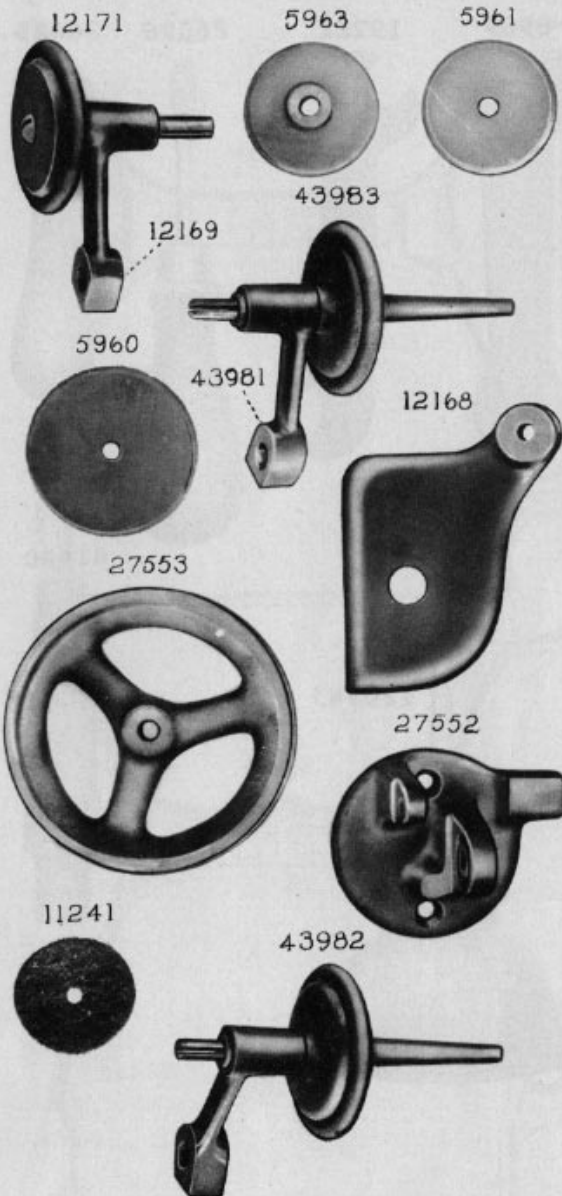


PLATE 6120—ONE-HALF SIZE

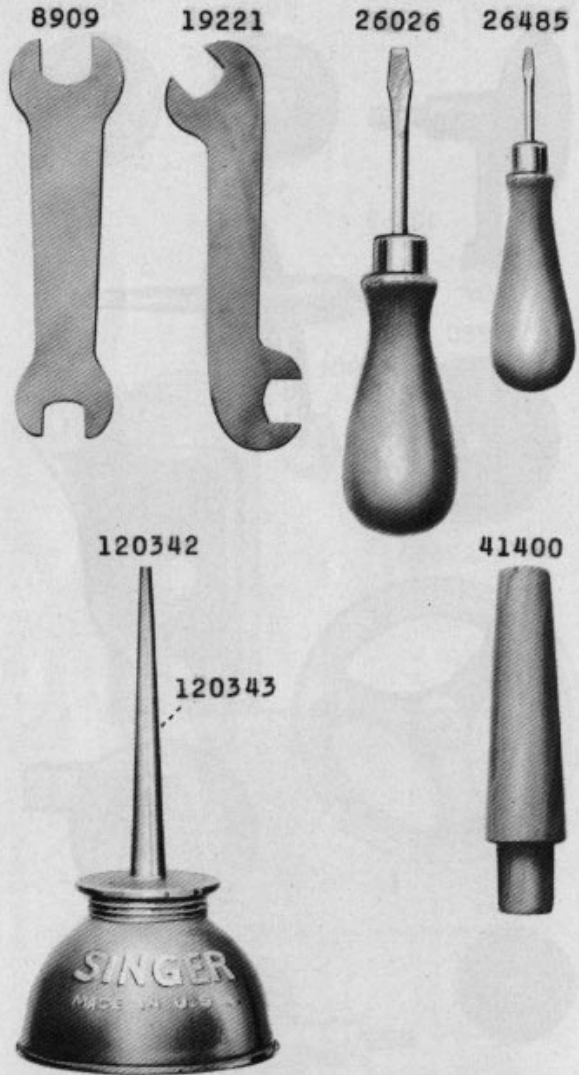


PLATE 6142—ONE-EIGHTH SIZE

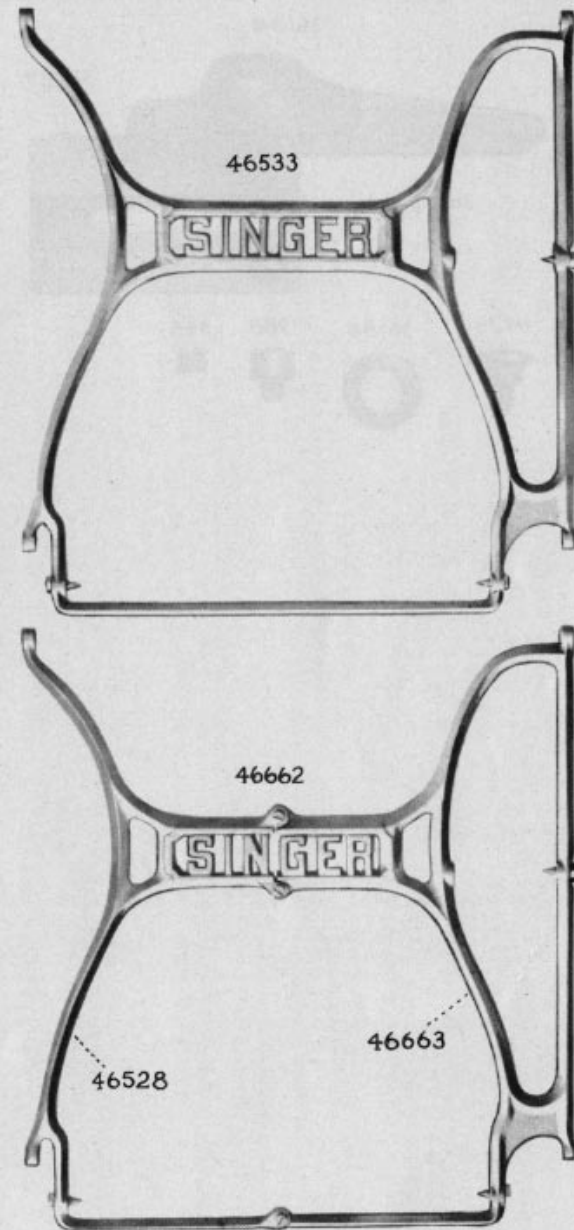
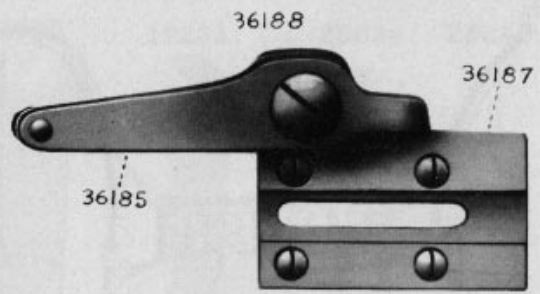


PLATE 6252-FULL SIZE





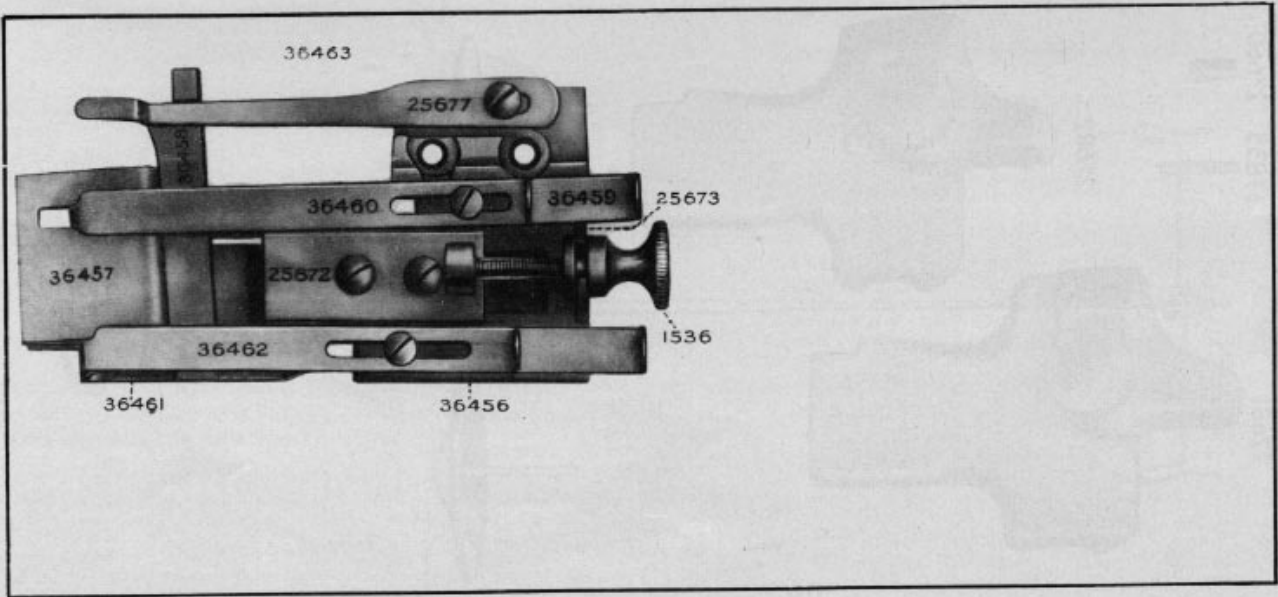
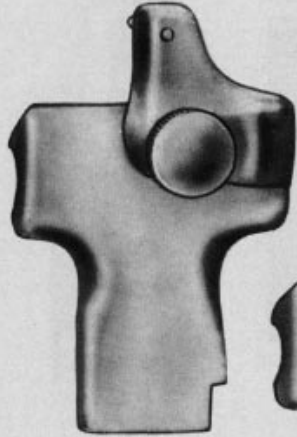


PLATE 6254 - FULL SIZE

PLATE 6255—FULL SIZE

27681



11833



27660



27682

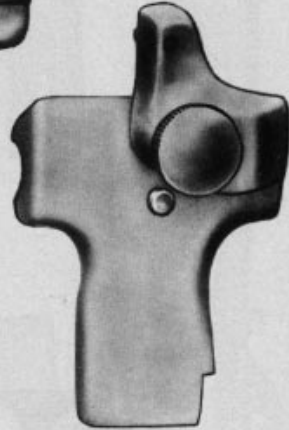


PLATE 7233—ONE-FOURTH SIZE

225396

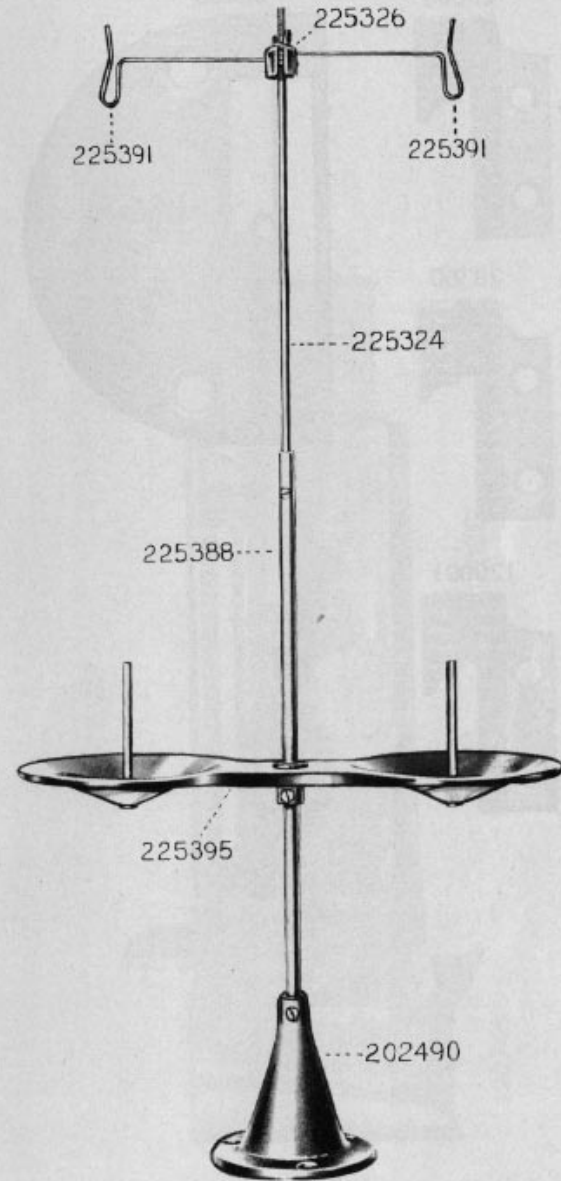
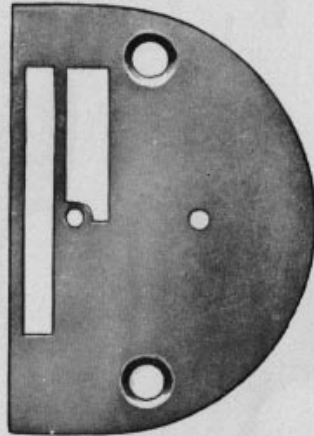


PLATE 7696—FULL SIZE

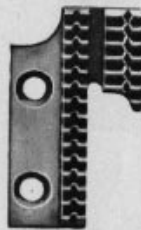
26603



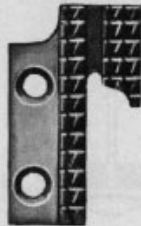
26605



28360



120001



52427



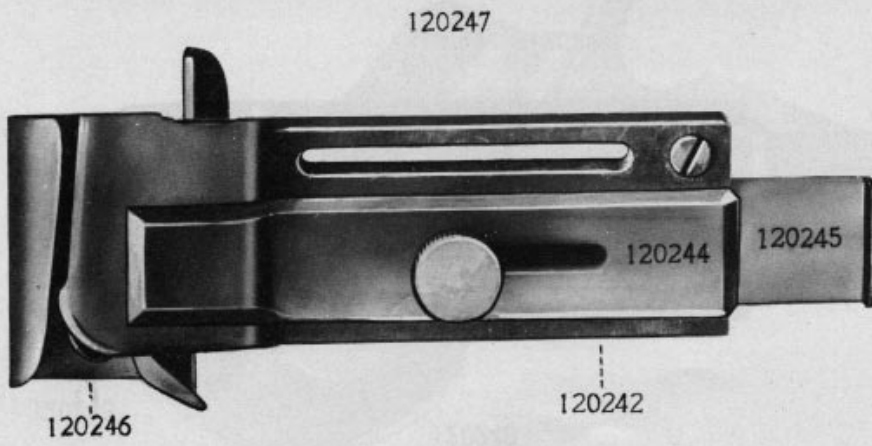
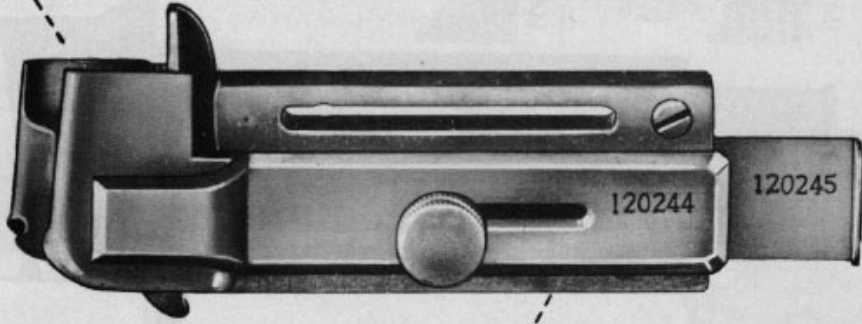


PLATE 7790—FULL SIZE

120243

120248



120242

120244

120245

PLATE 7791—FULL SIZE

120337

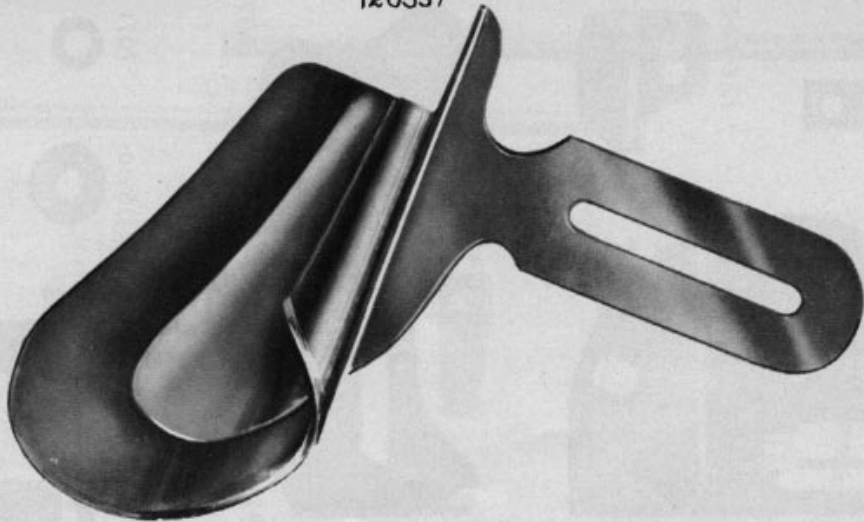
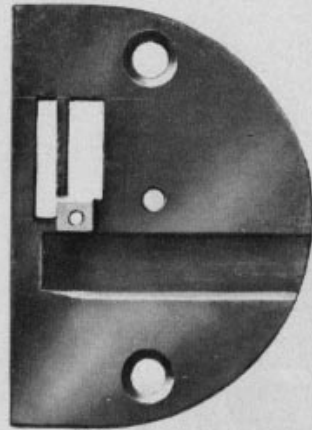


PLATE 8210—FULL SIZE

PLATE 8211—FULL SIZE

120436



120434

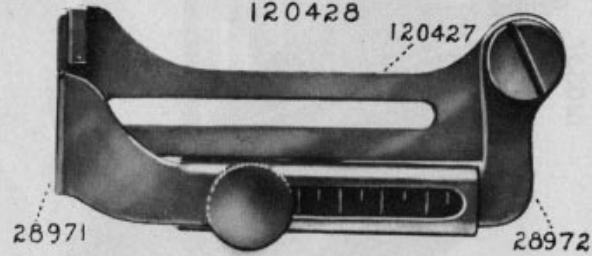


120433



120428

120427



28971

28972

120435



120458



35610



286



7071



940



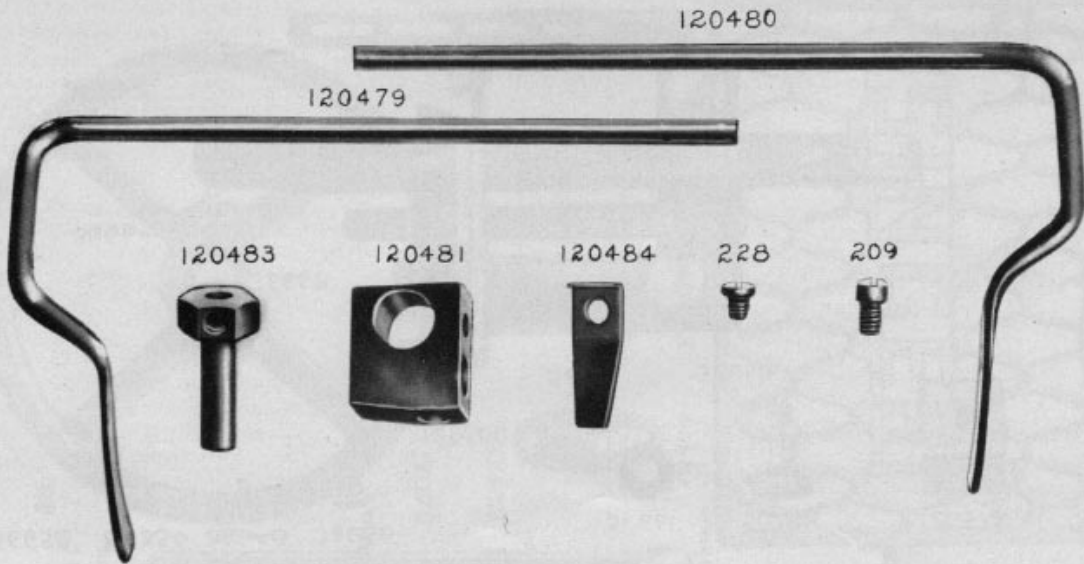
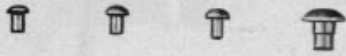


PLATE 8212—FULL SIZE



36658 86354 36648 36656



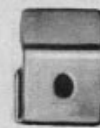
36661



502.38



120572



36657



120500

36561

36660

36667

36664

36662

36655

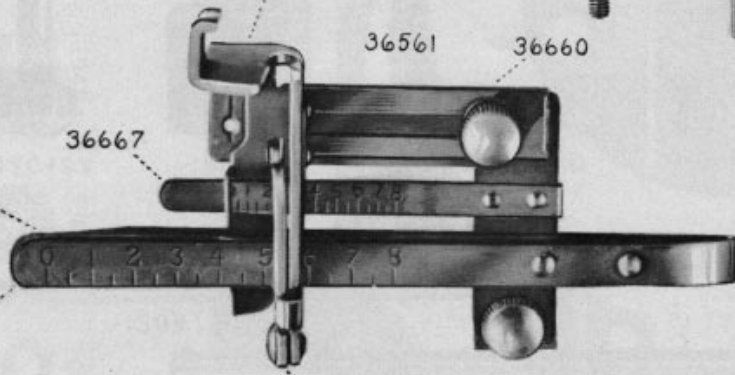


PLATE 8213—FULL SIZE



PLATE 8497—ONE-FOURTH SIZE

126036



126038



126205



60858



46681



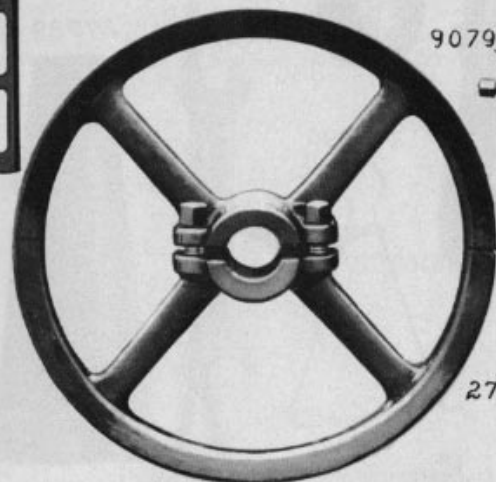
60626



27070

27639

9079



27639

PLATE 8520—ONE-HALF SIZE



PLATE 8523—ONE-SIXTH SIZE

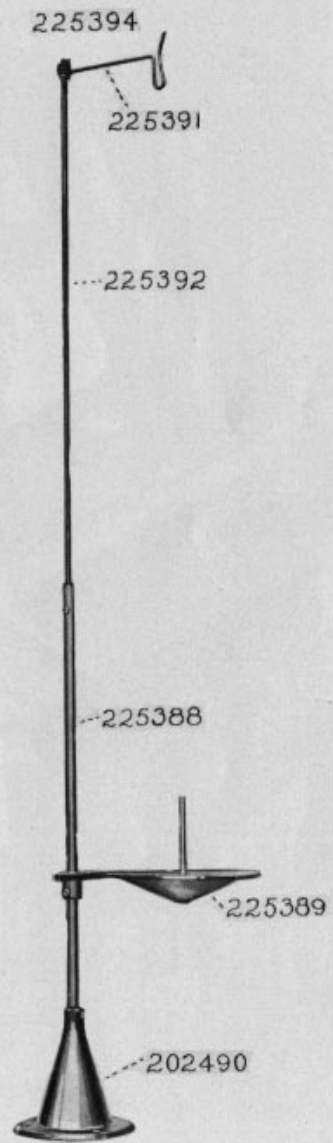


PLATE 8625—FULL SIZE

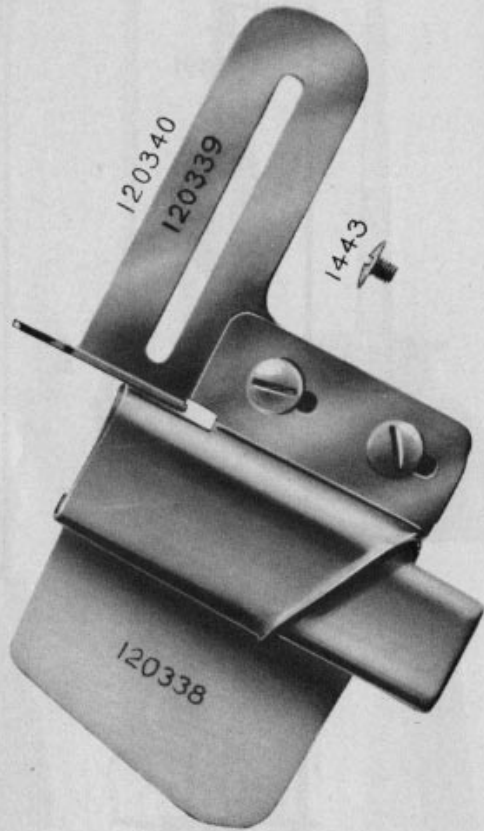


PLATE 8627—FULL SIZE

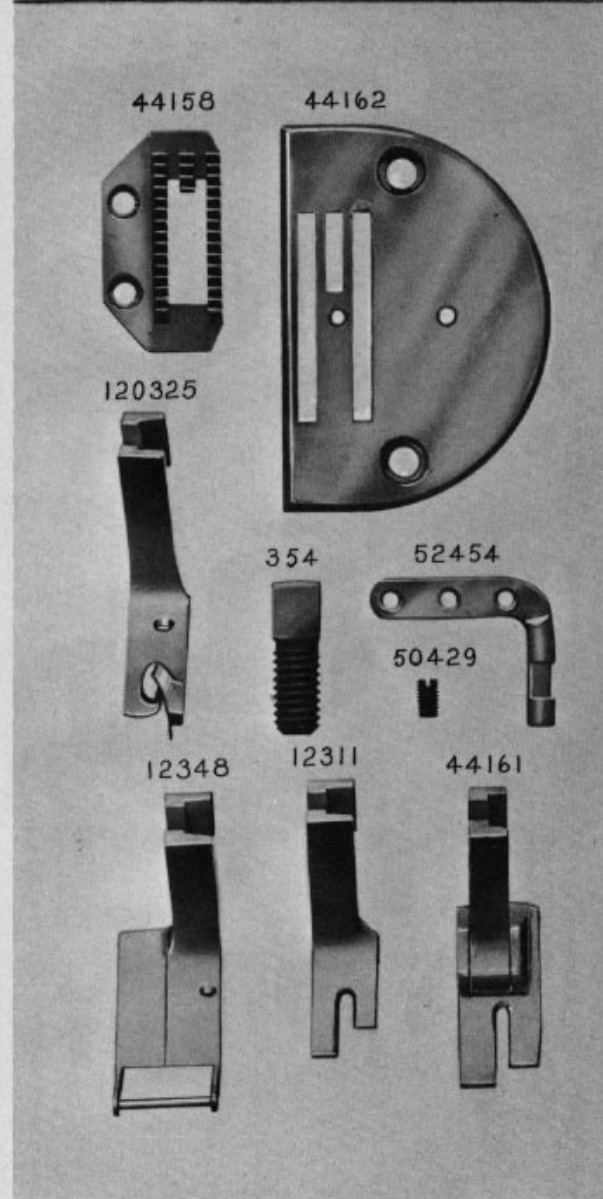


PLATE 8628—FULL SIZE



PLATE 8629—ONE-HALF SIZE

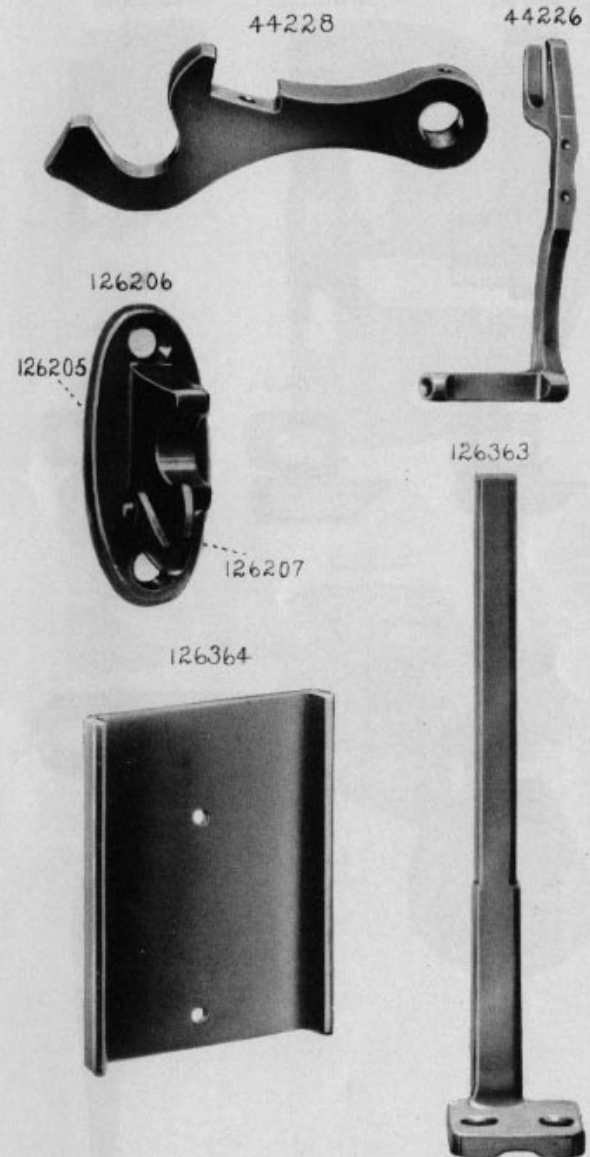


PLATE 8630—FULL SIZE

35350



26686



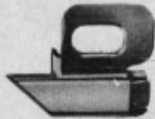
120466



120493



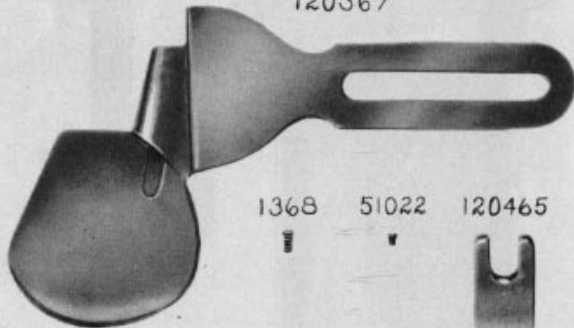
120494



120495



120367



1368



51022



120465

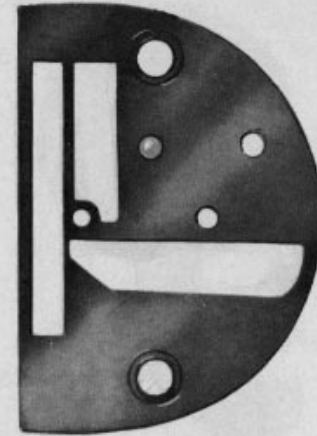


1886  
PLATE 8631—FULL SIZE

26603



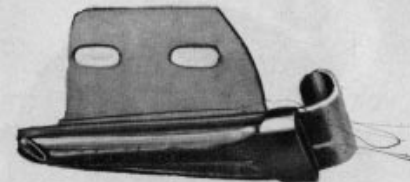
120540



120534



120532



51097



11656



43525





PLATE 8632—ONE-HALF SIZE

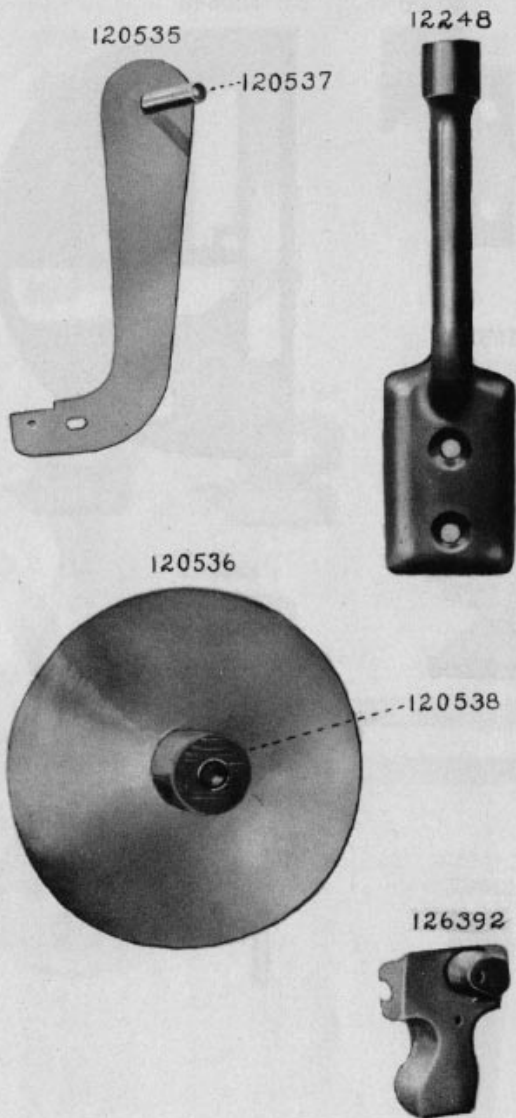


PLATE 8633—FULL SIZE

