

SINGER
81K1,K13,K20,K24

Form K5563
(110)
Printed in Great Britain

ILLUSTRATED
LIST OF PARTS
FOR
CLASS 81K MACHINES
(81K1 to 81K13 and 81K20 to 81K21)

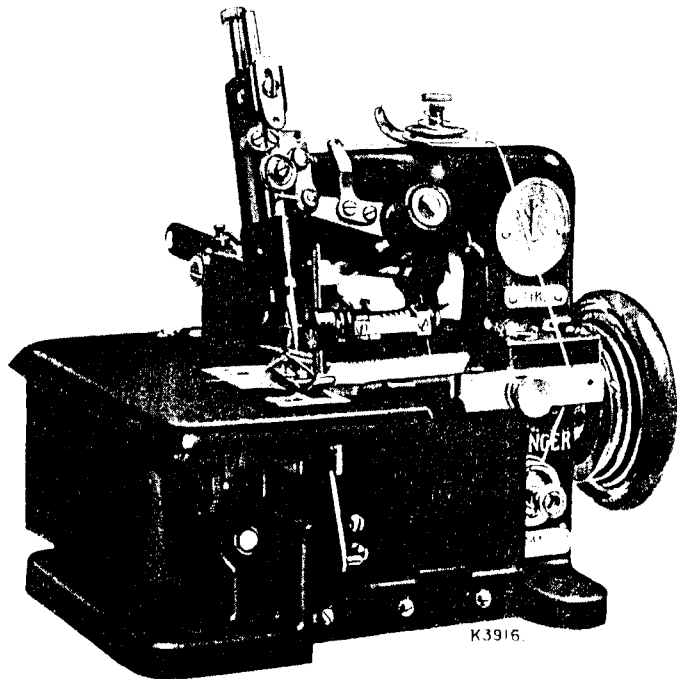

Machine No. 81K3

THE SINGER MANUFACTURING COMPANY

All Rights Reserved

42362

42266

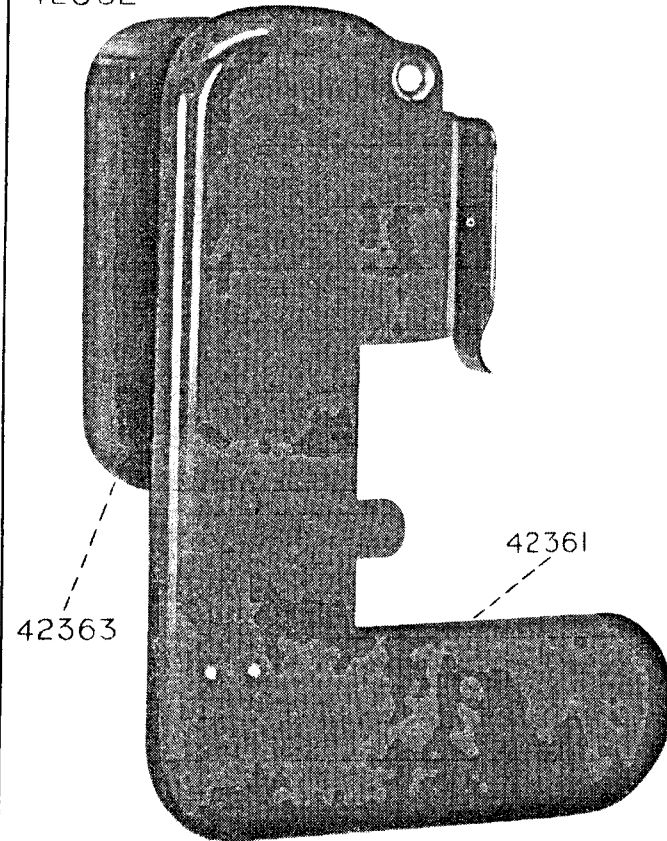

42363

42361

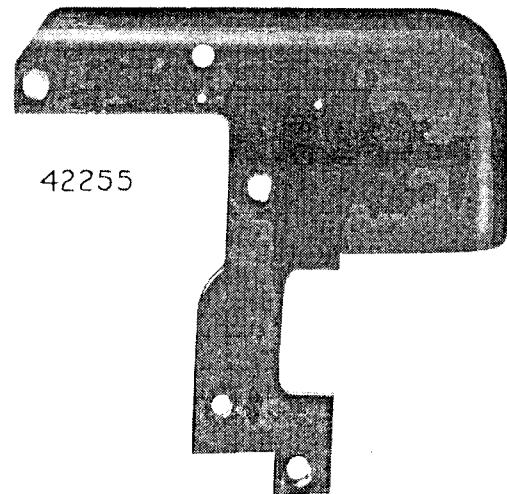
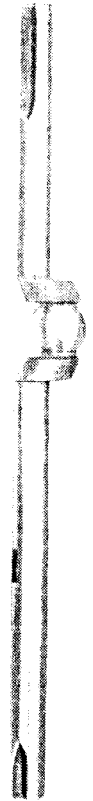

42255

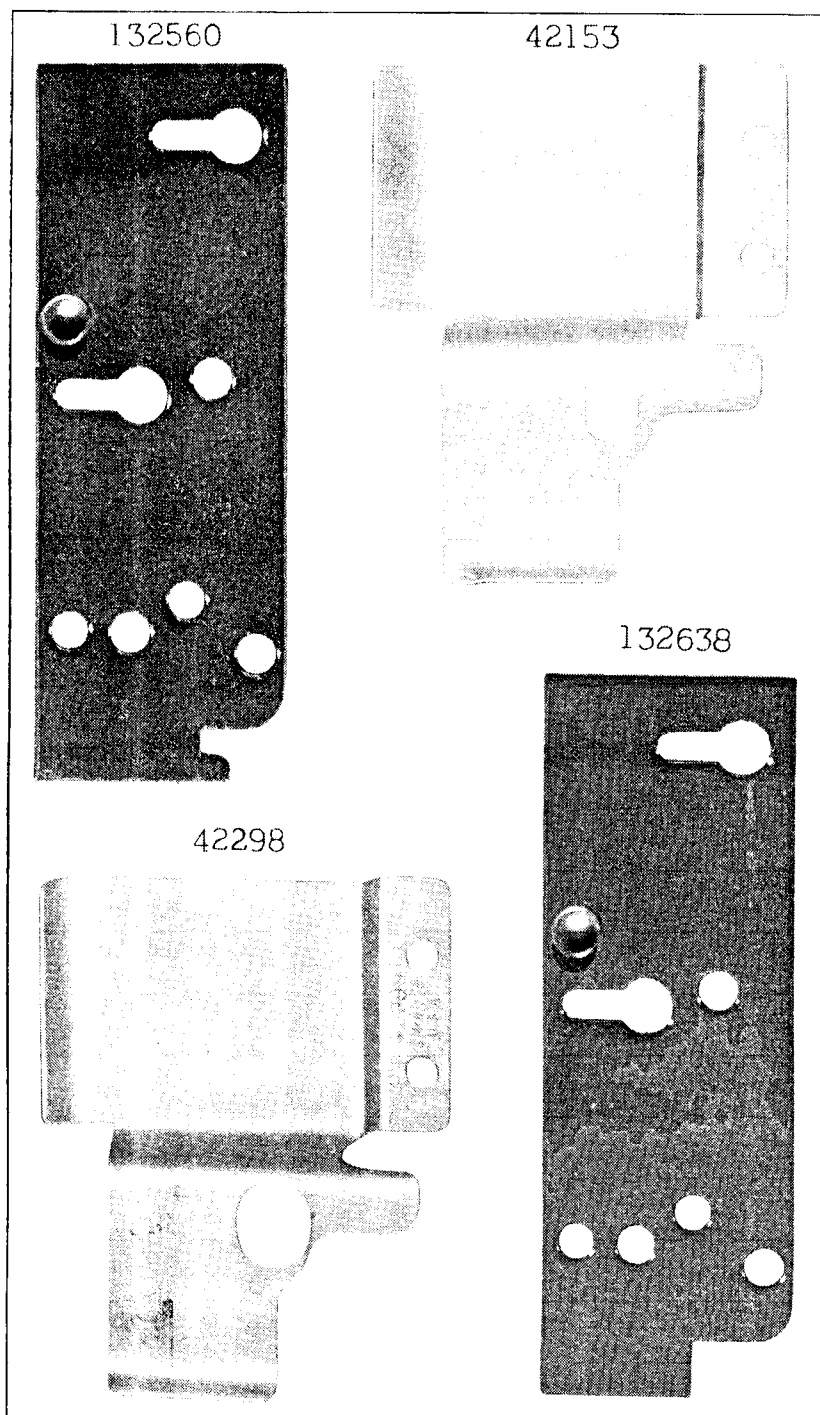
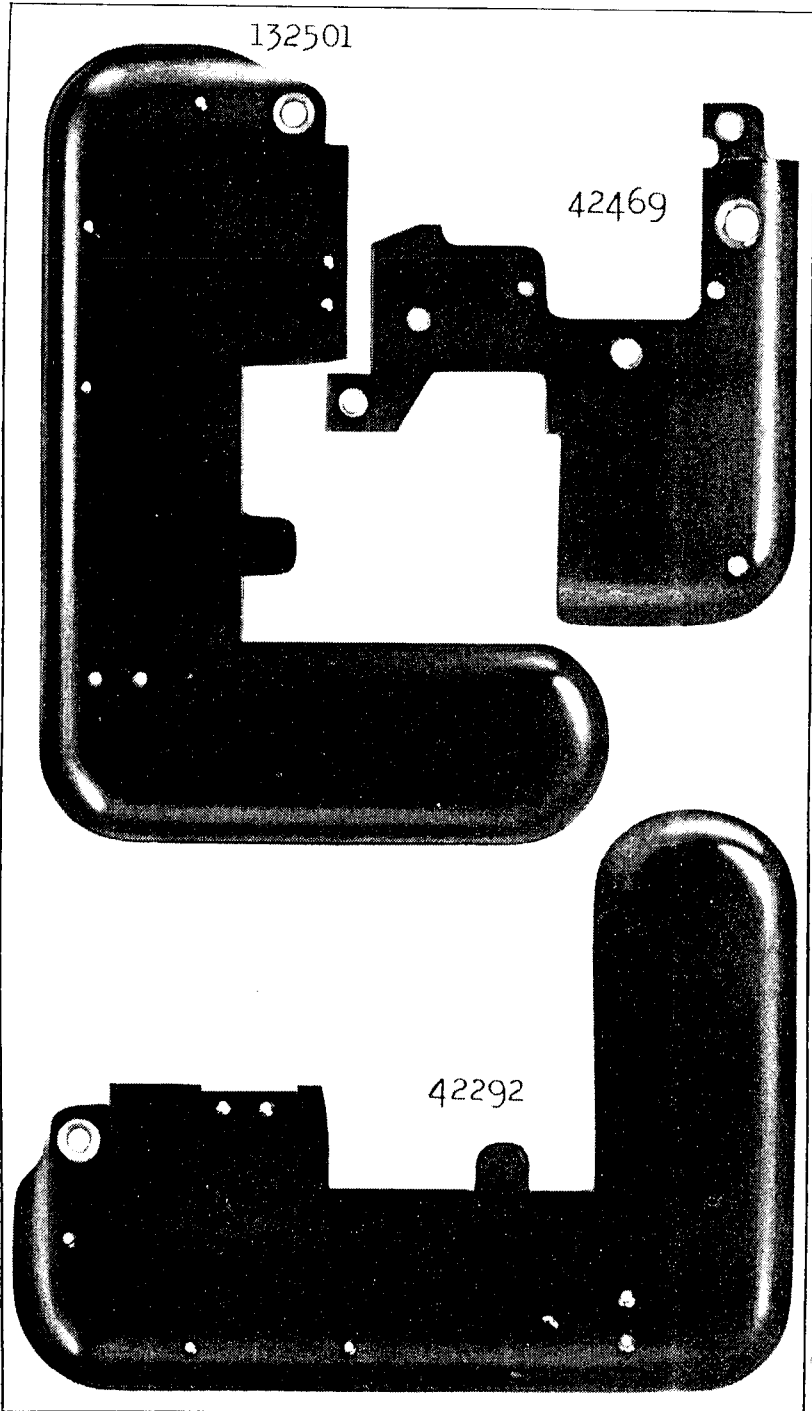

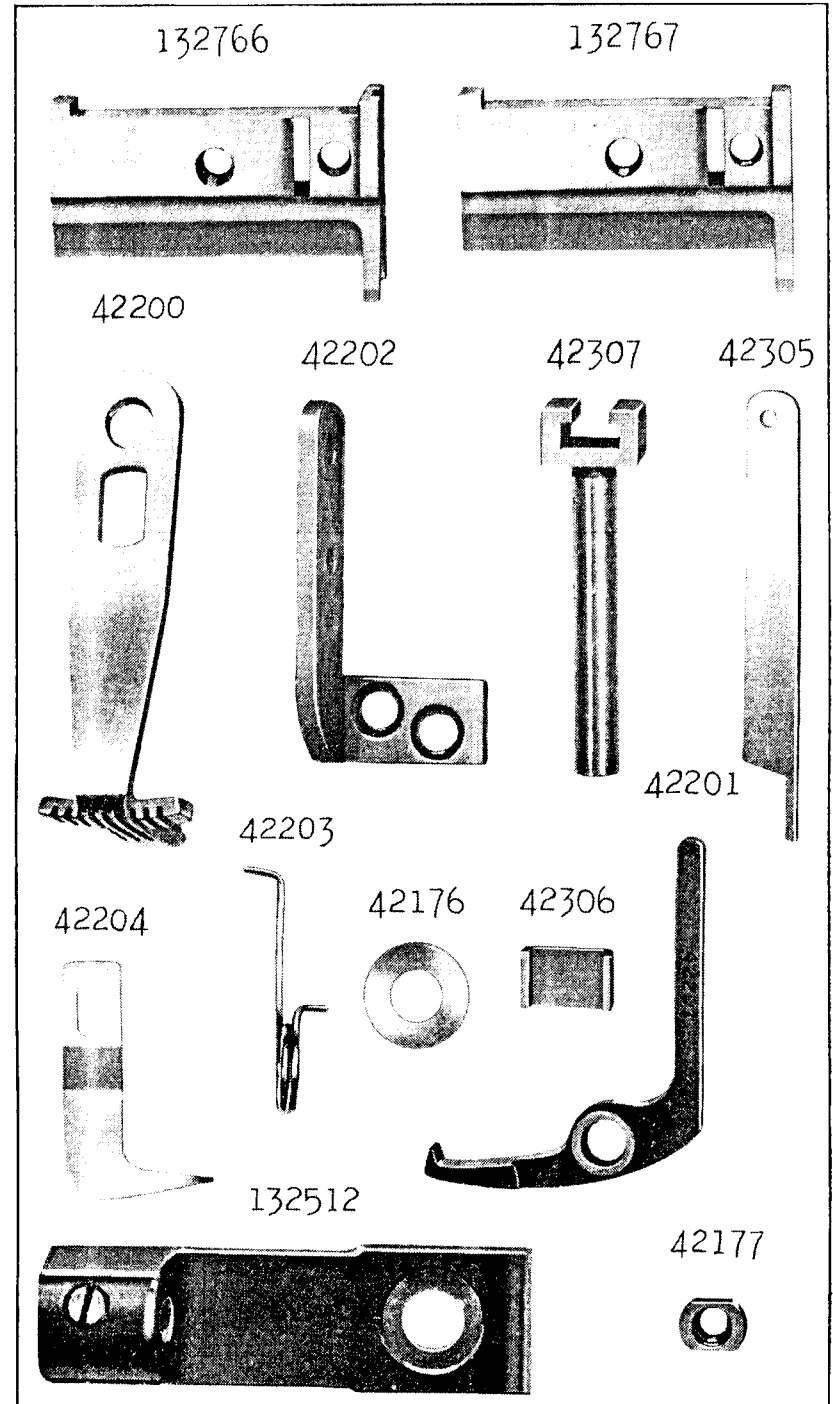
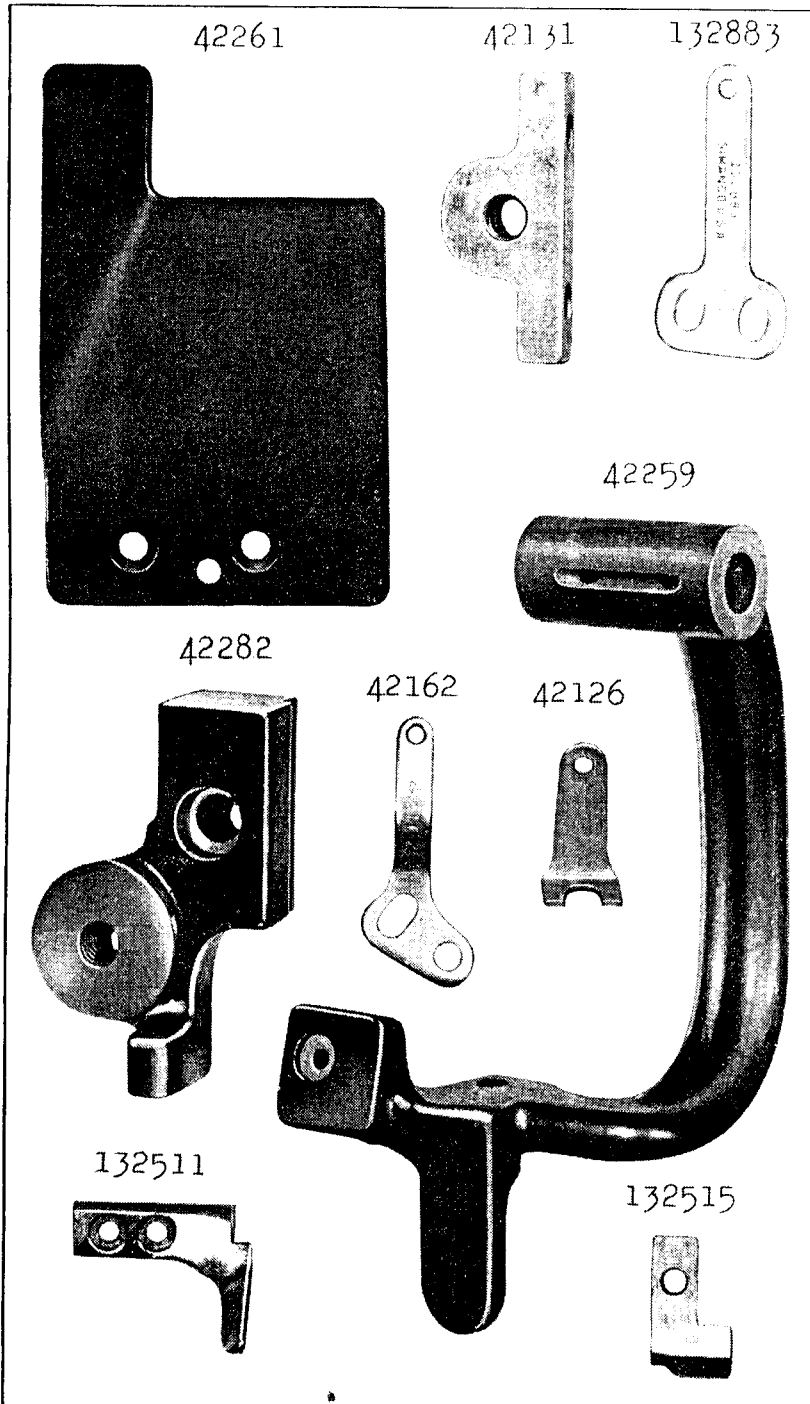

42296

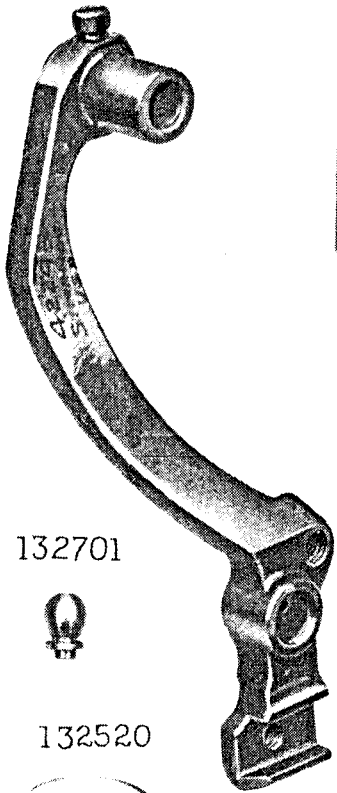

132505

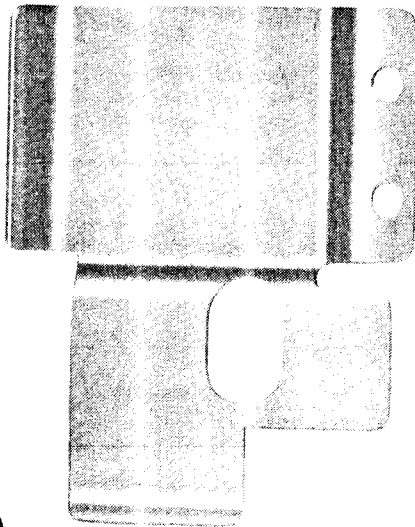

132701



132650

132098

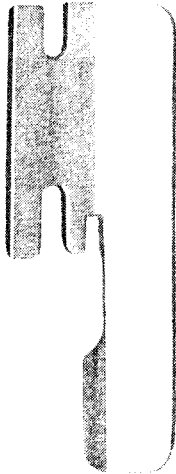

132520

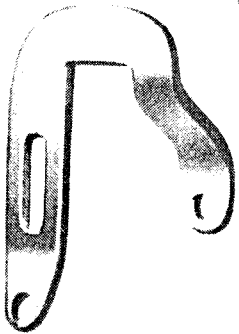

132506

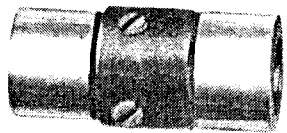

42260

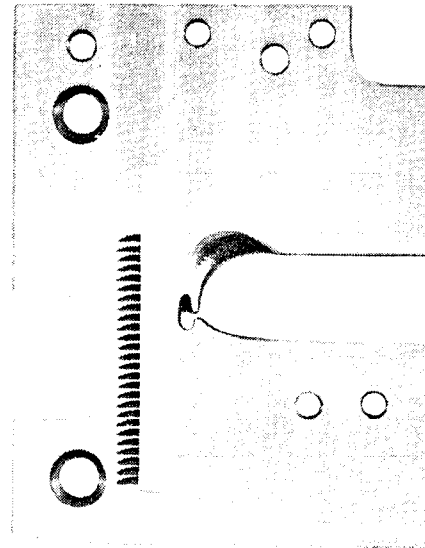

42257

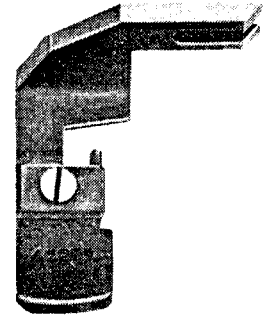

132663

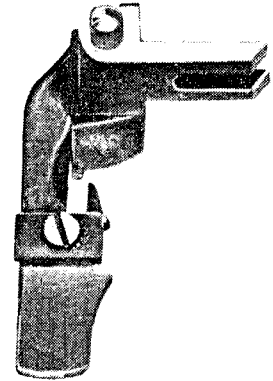

42482

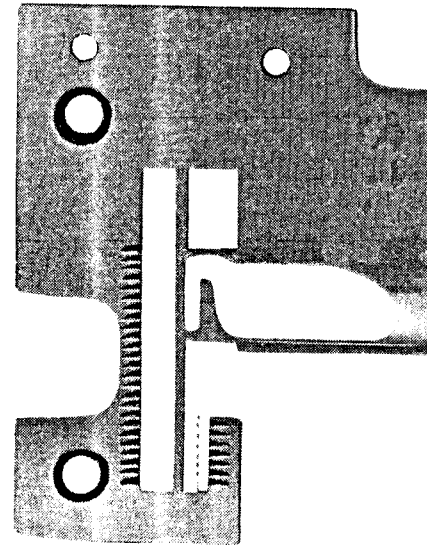

42481

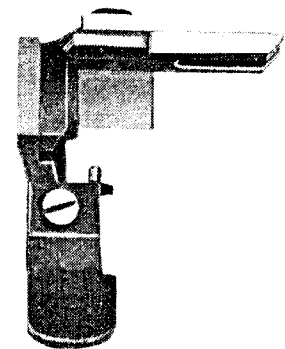

42472

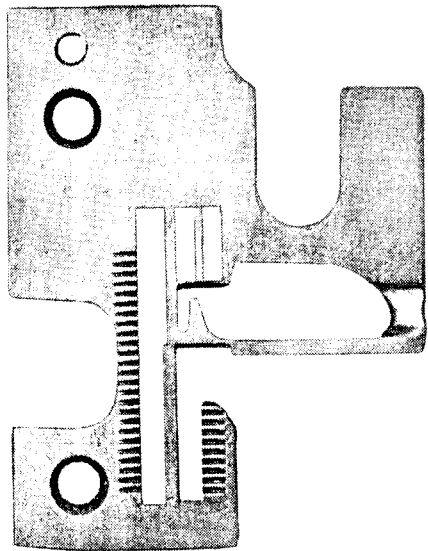

42471

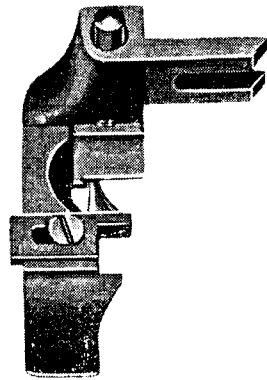

42460

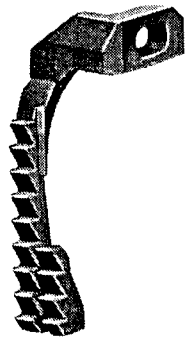

42075

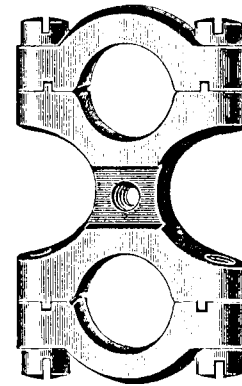

35864

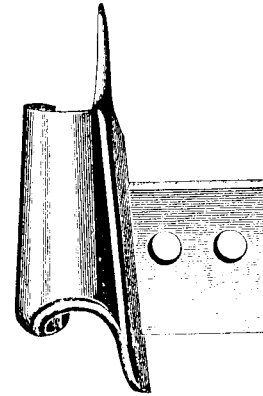

42227

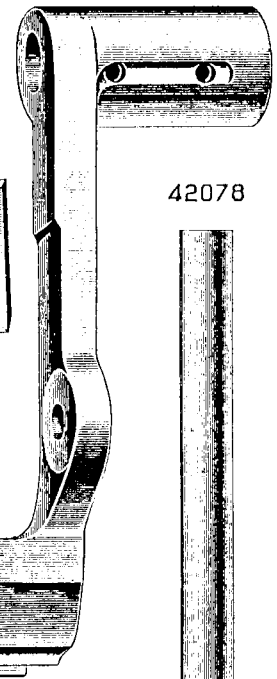

42078

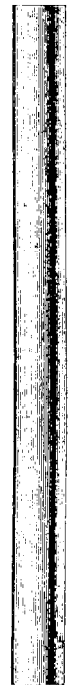

42073

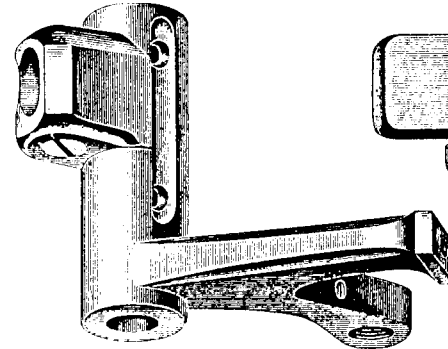

42052

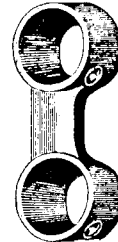

42074



42077

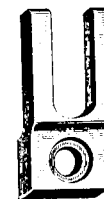

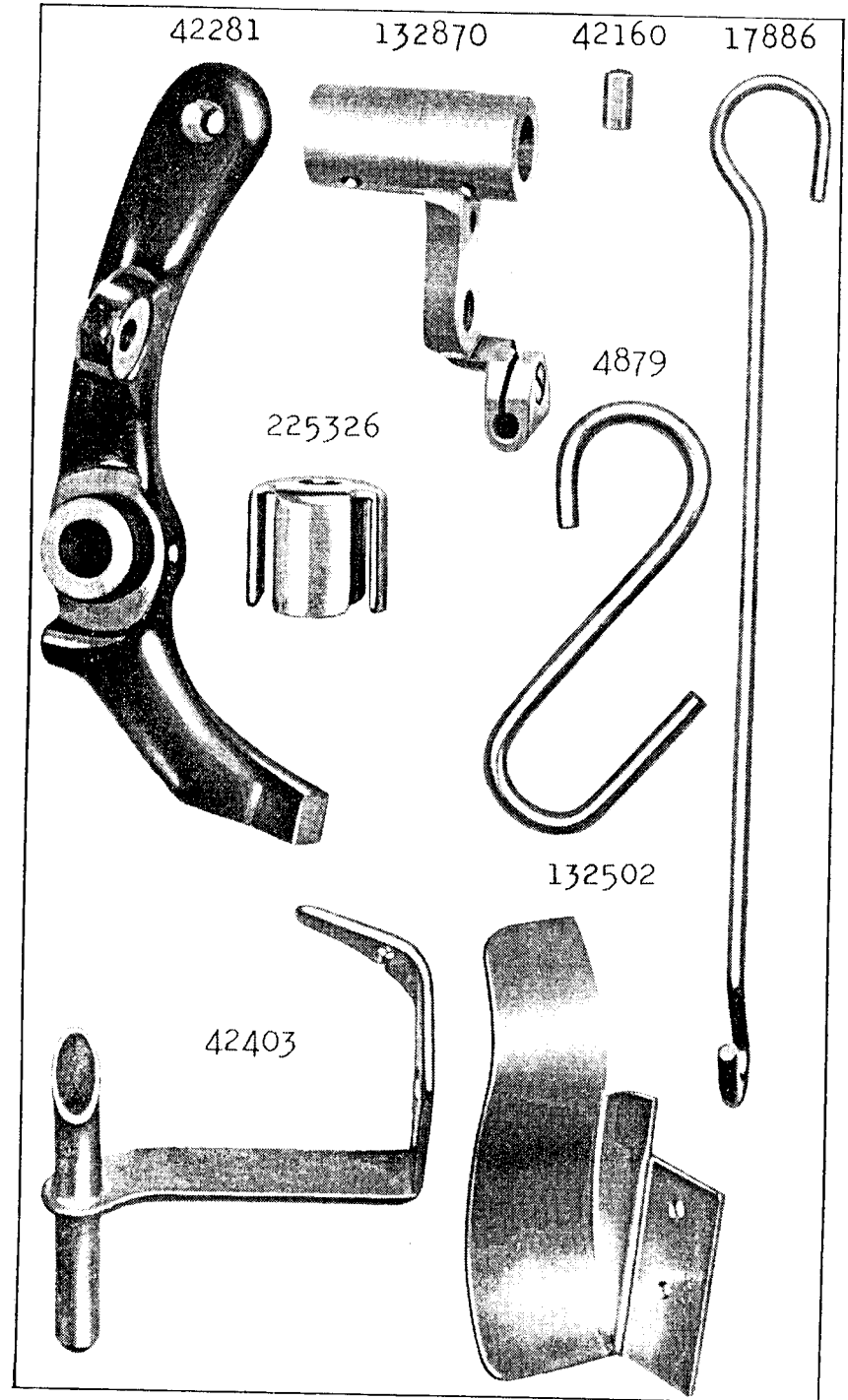
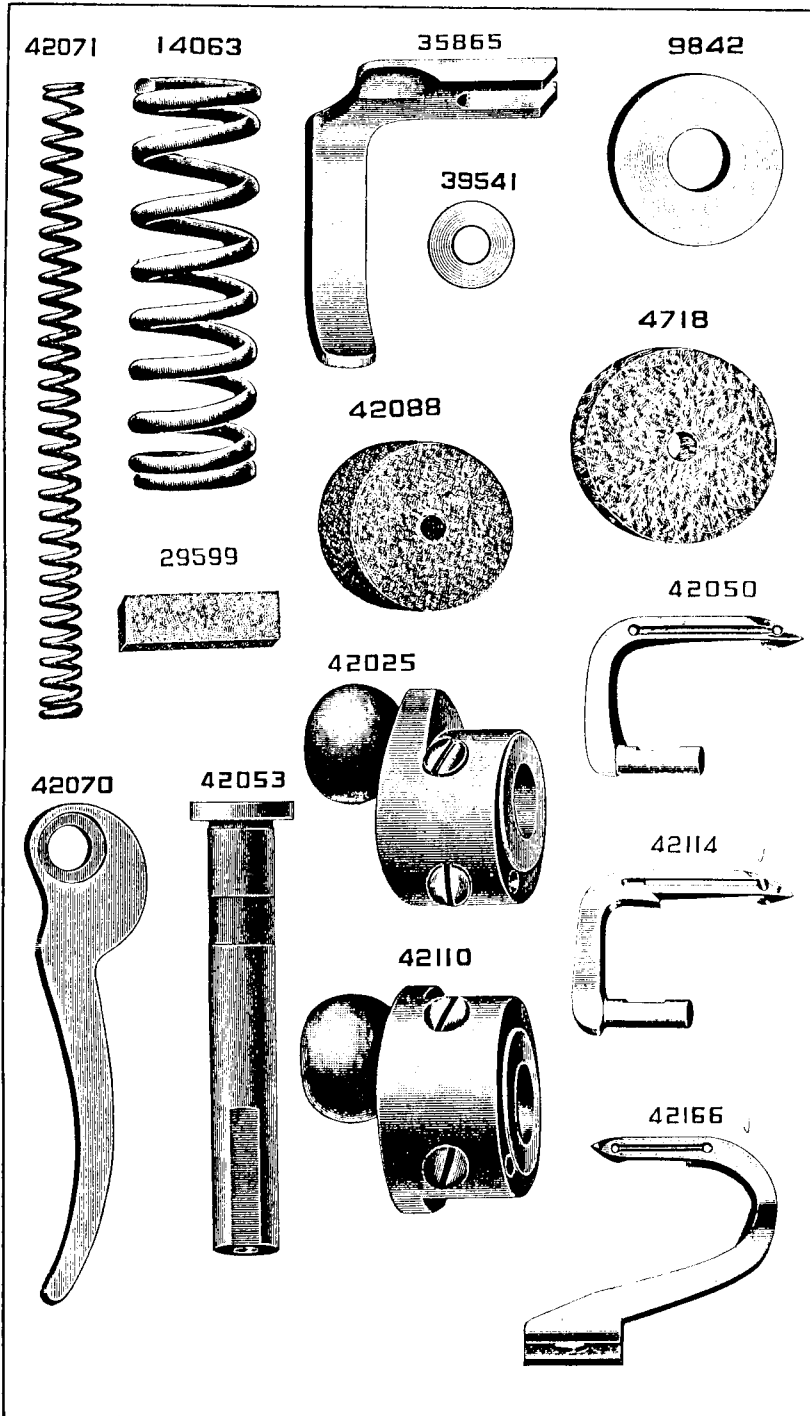

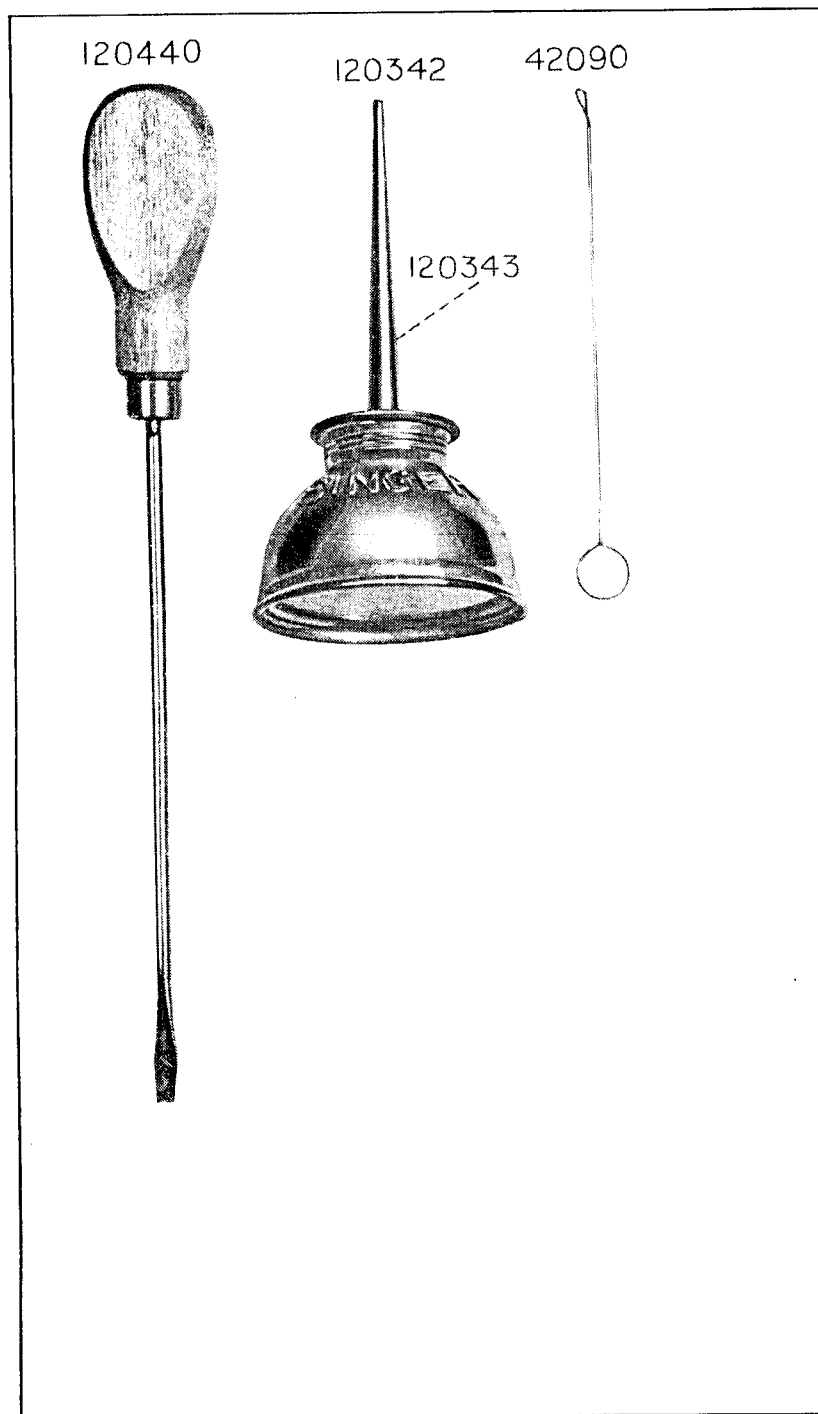
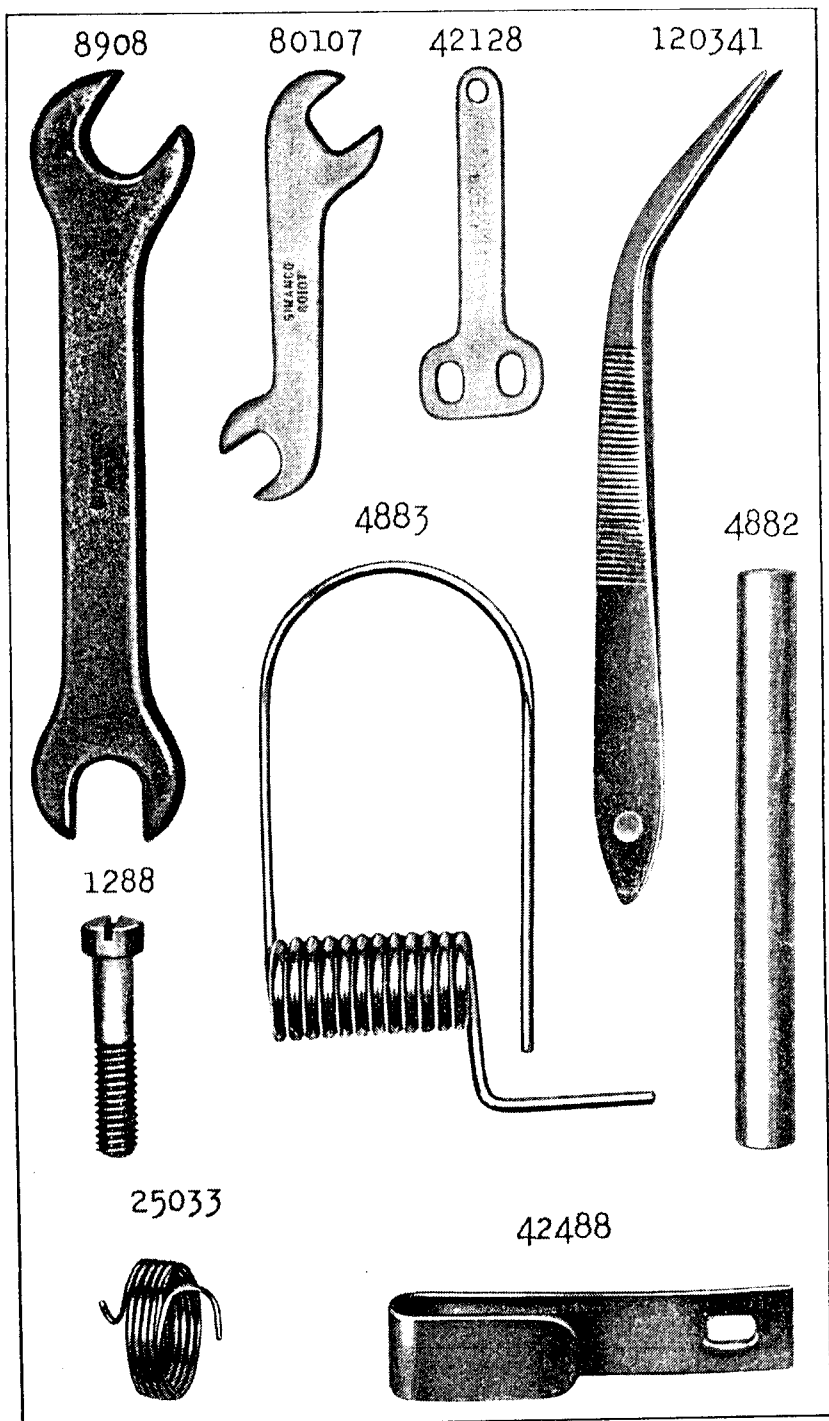

42089

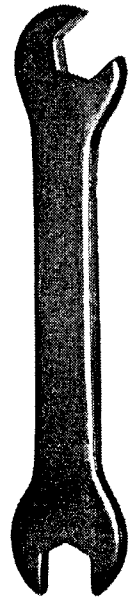

132631

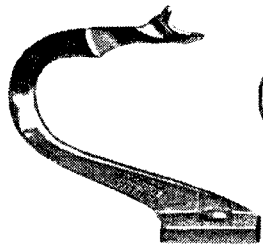

42256

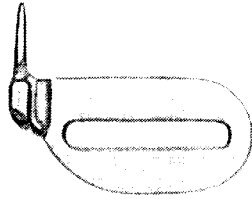

14058



9525



225322



213



464



1231



1240



1250



50117



201696



35

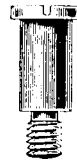

85



164



172



193



208



229



236



330



356



424



742

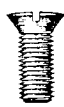

935



949



1354



1375



1377



1378

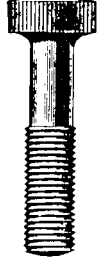

1437

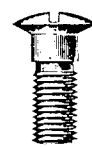

1655



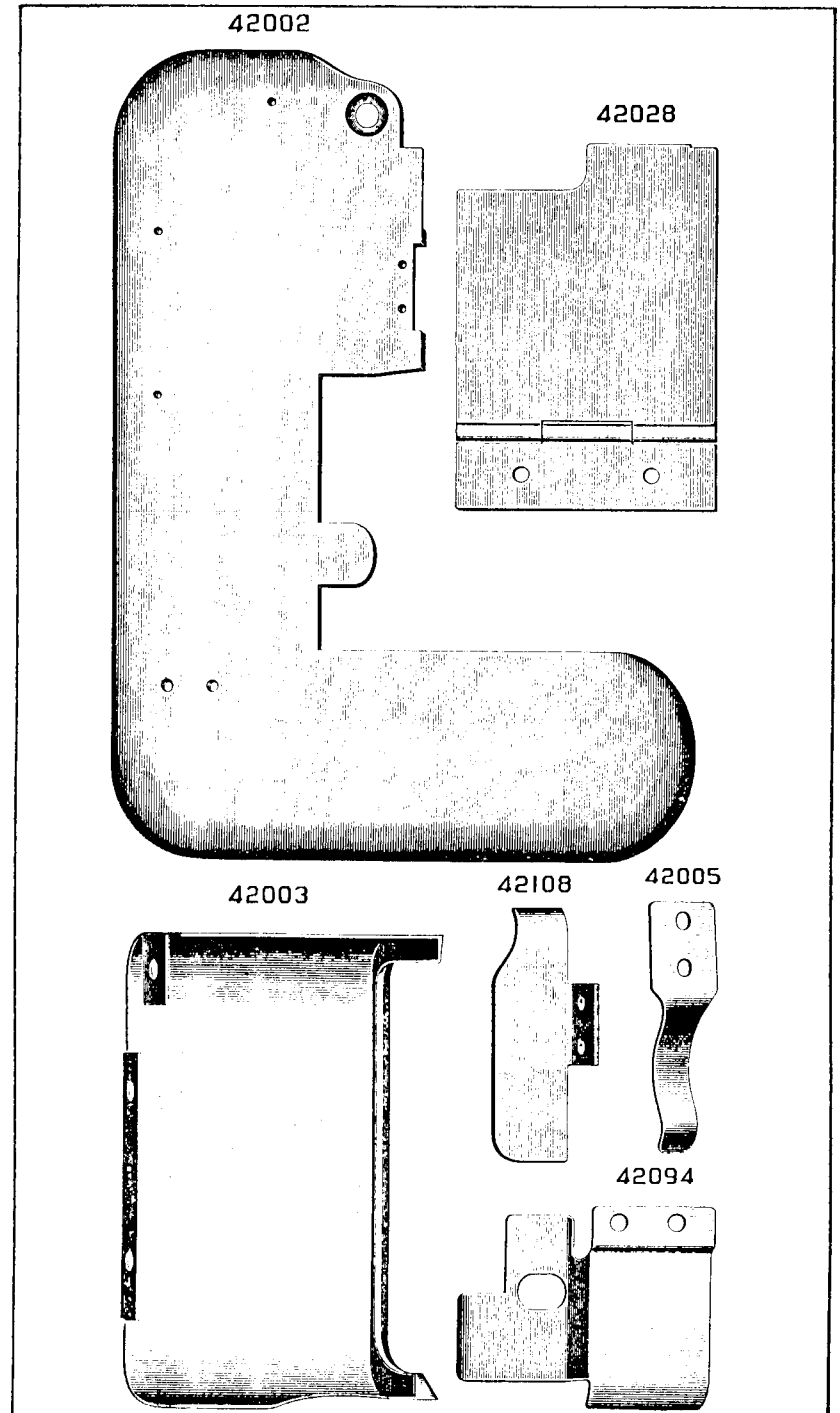

42229

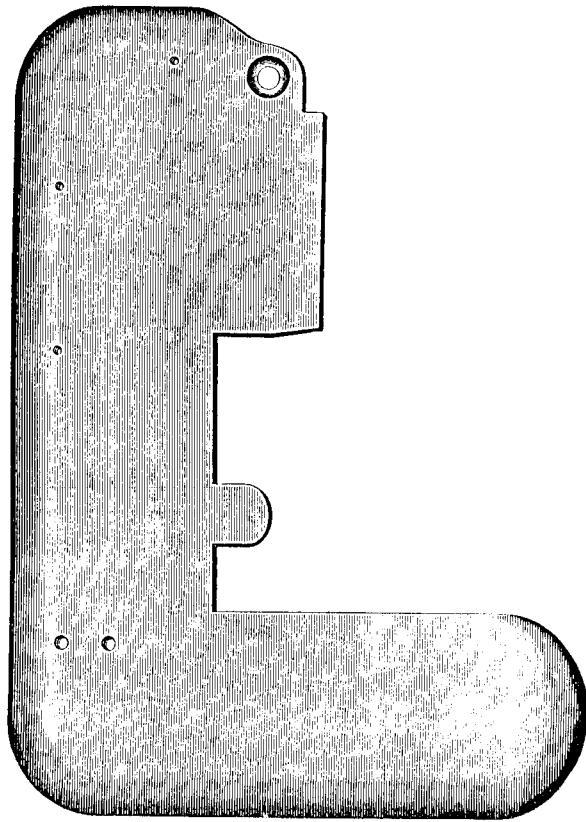

42231

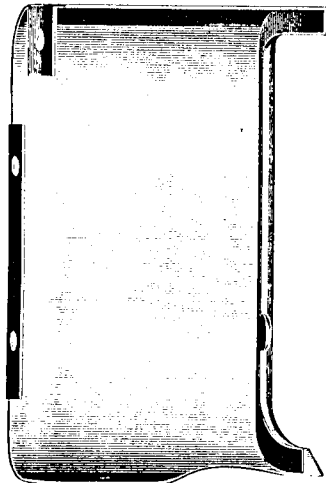

42007

42006

42008

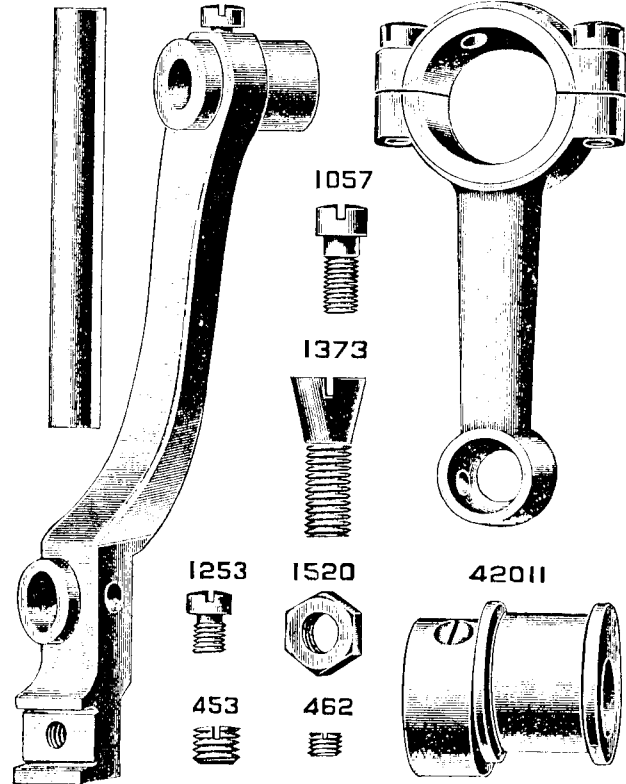

42012

42015

42017

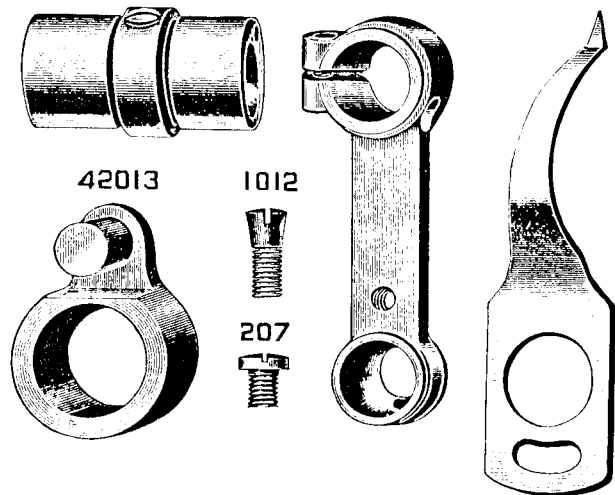

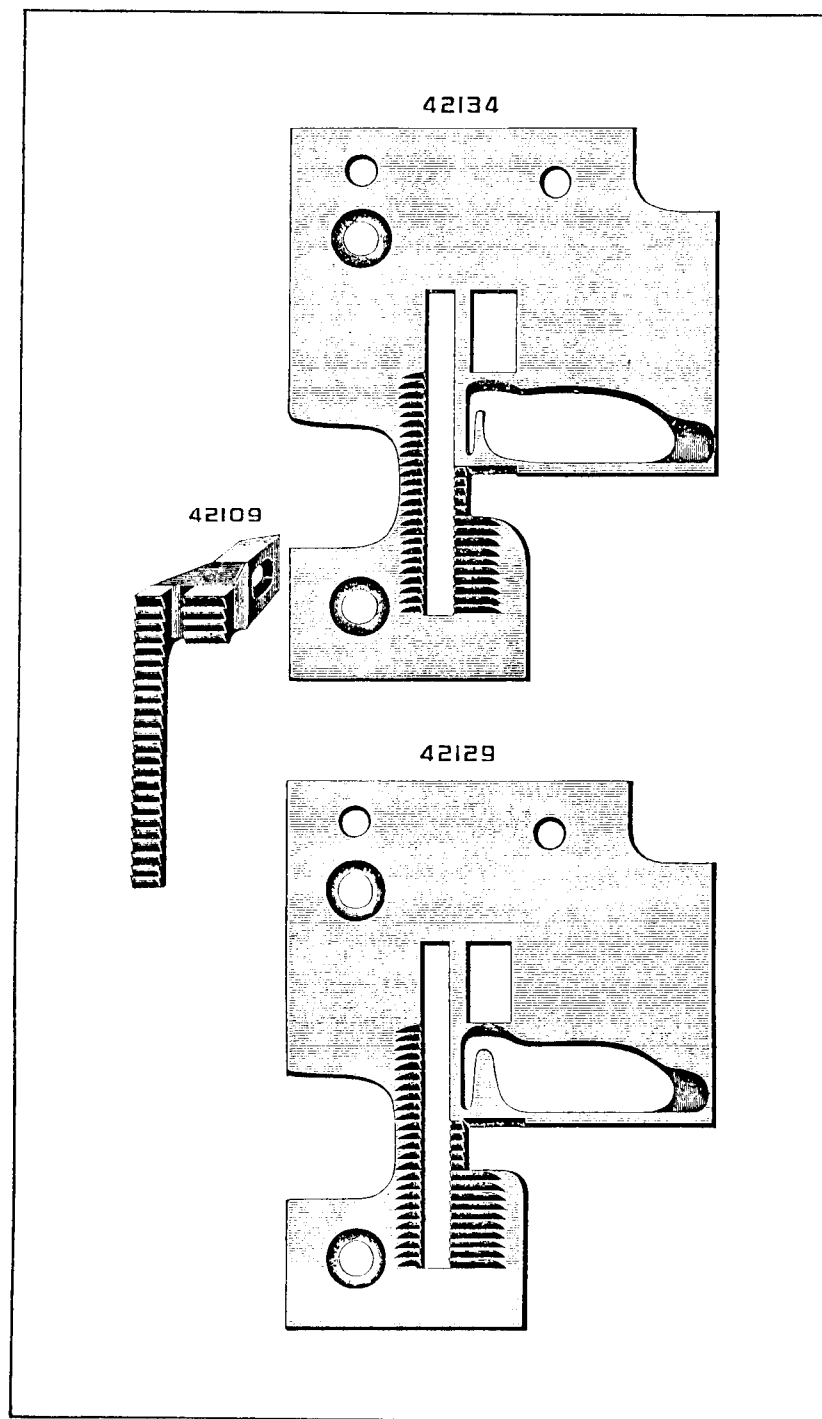
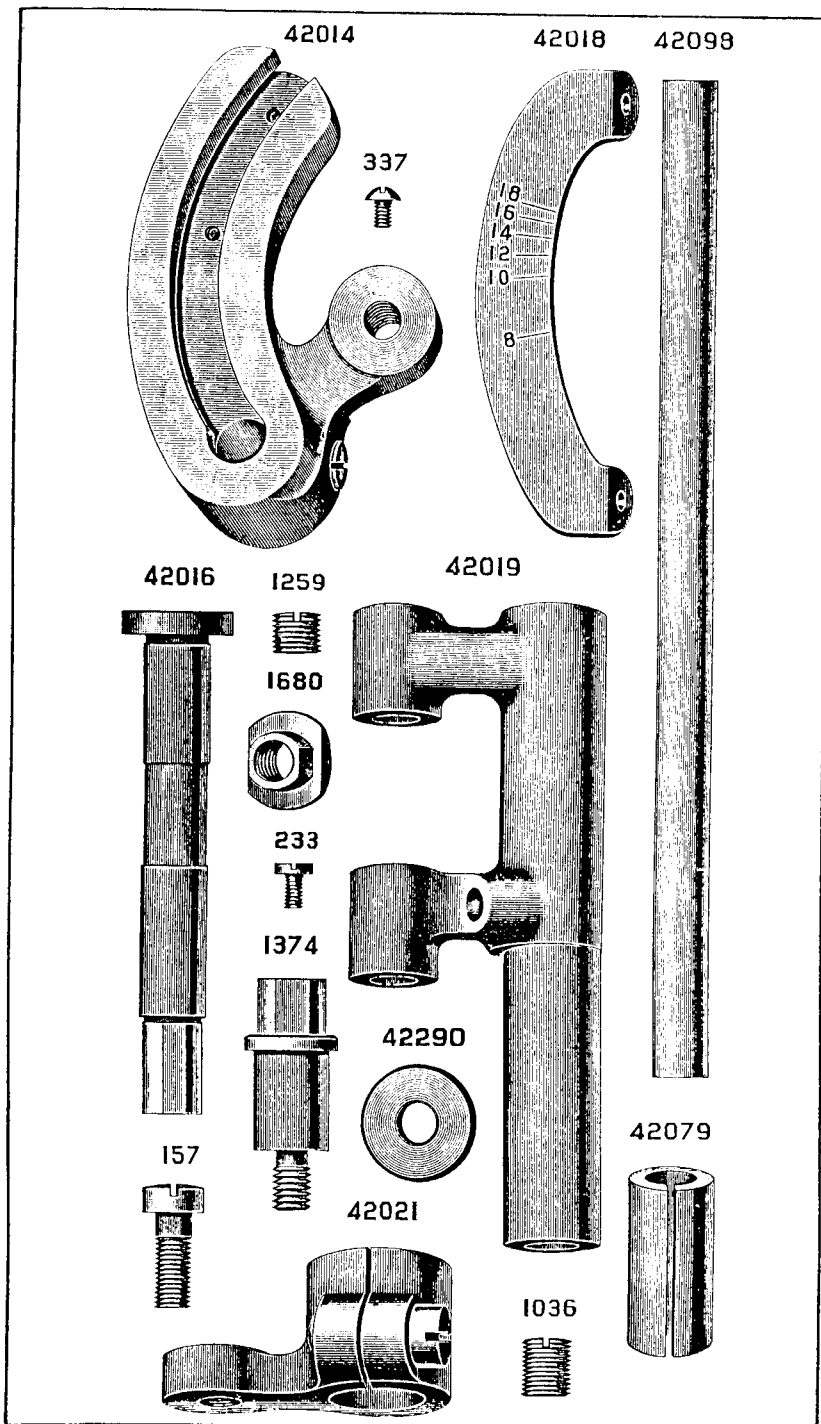

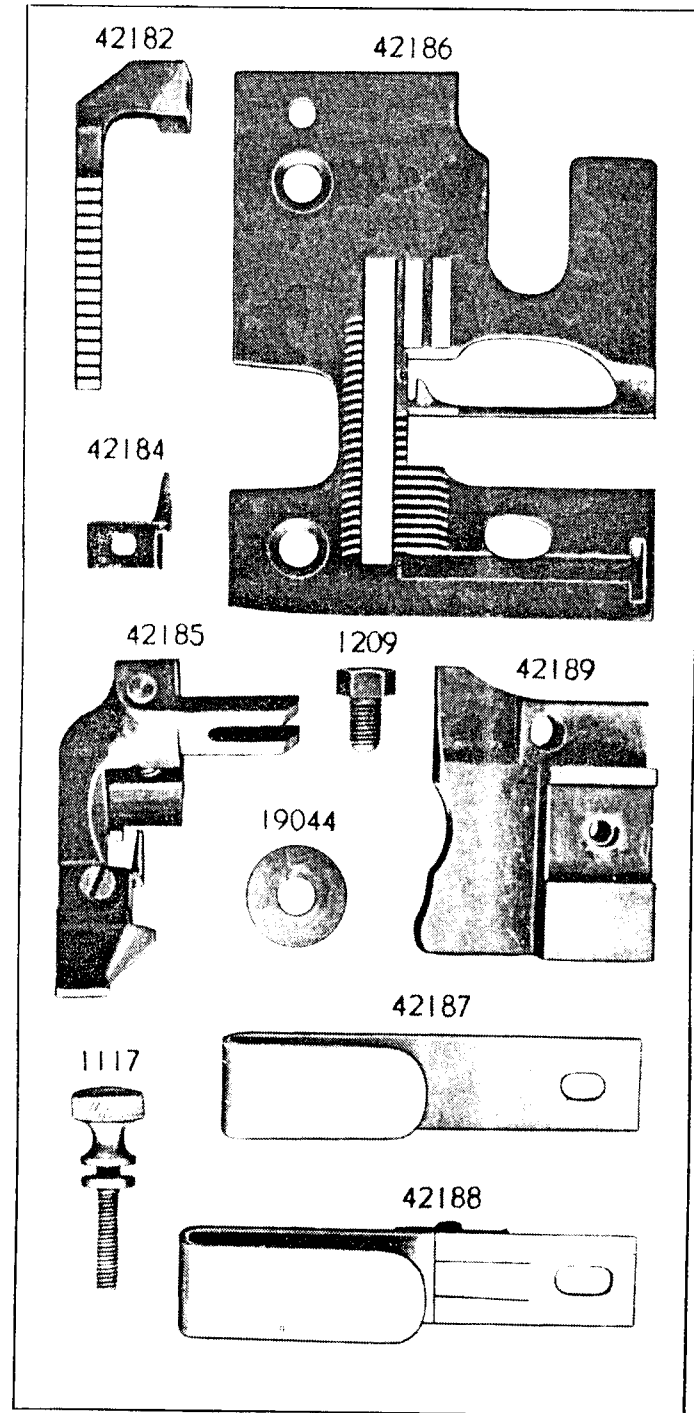
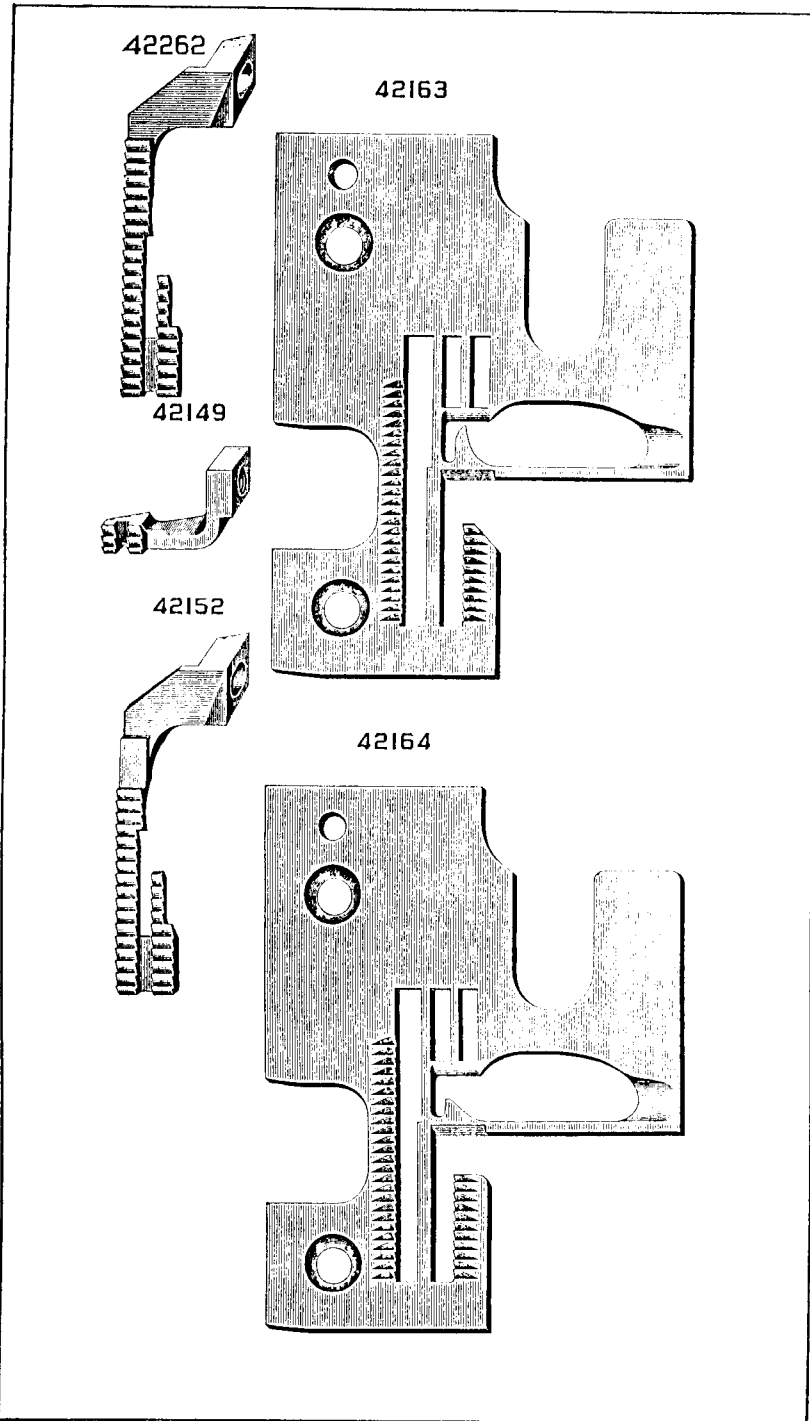

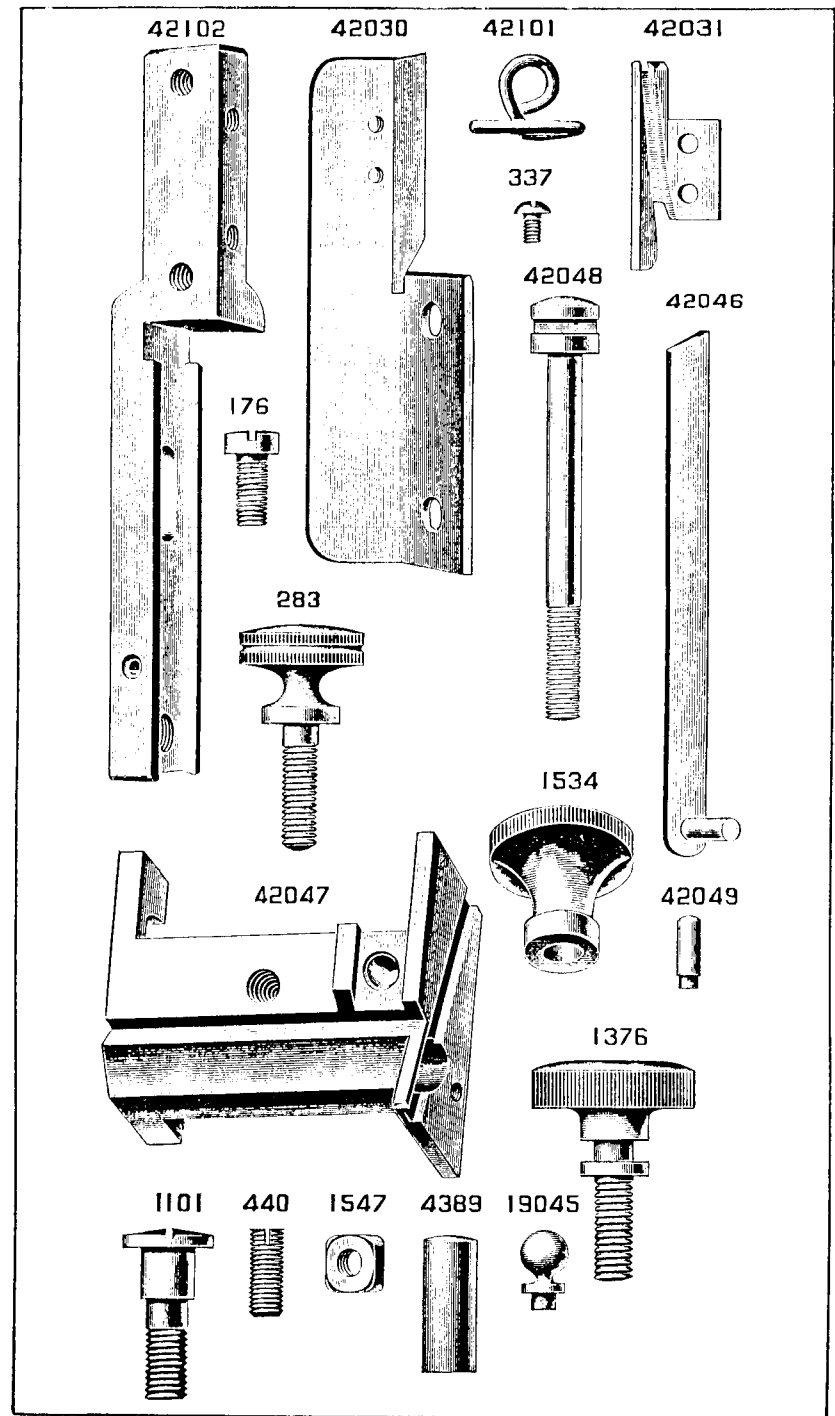
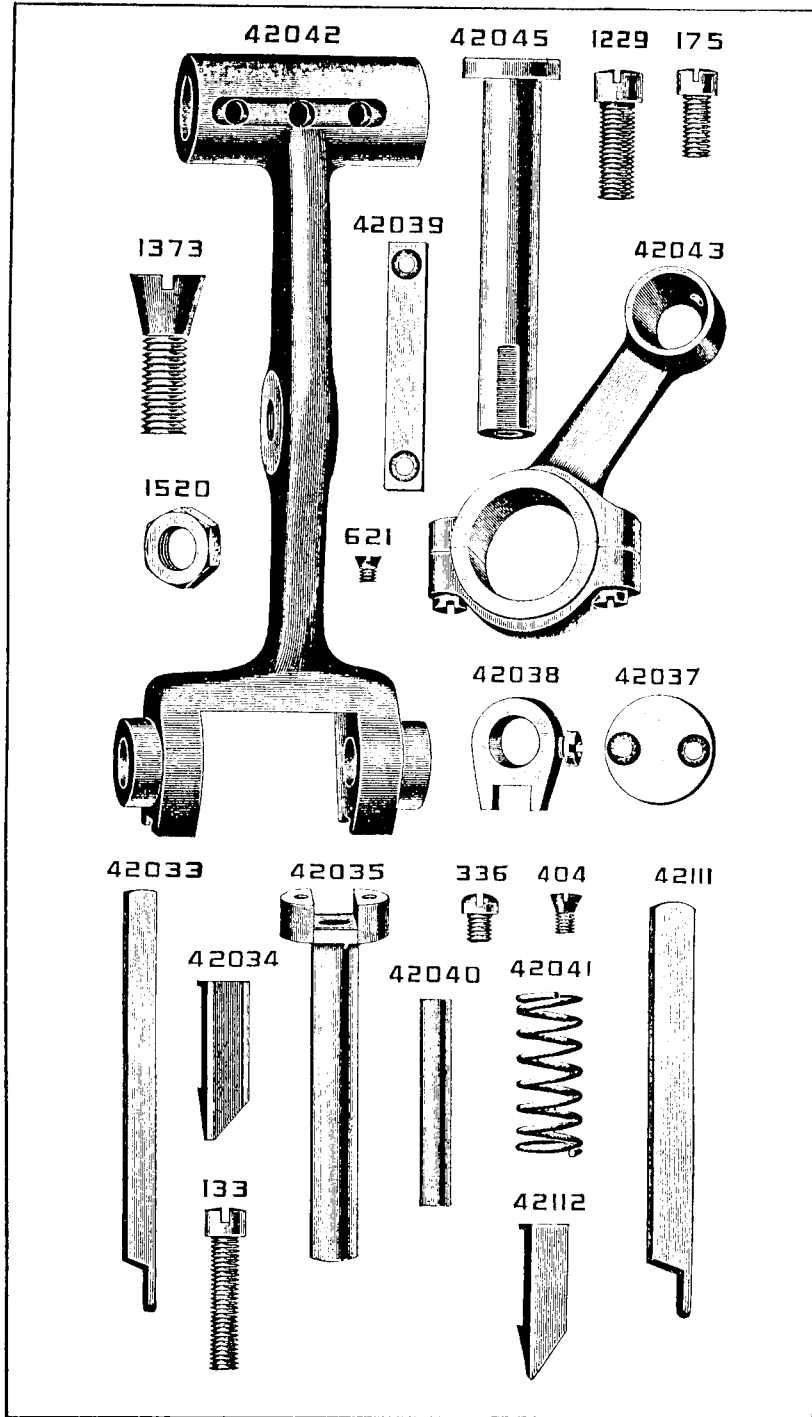

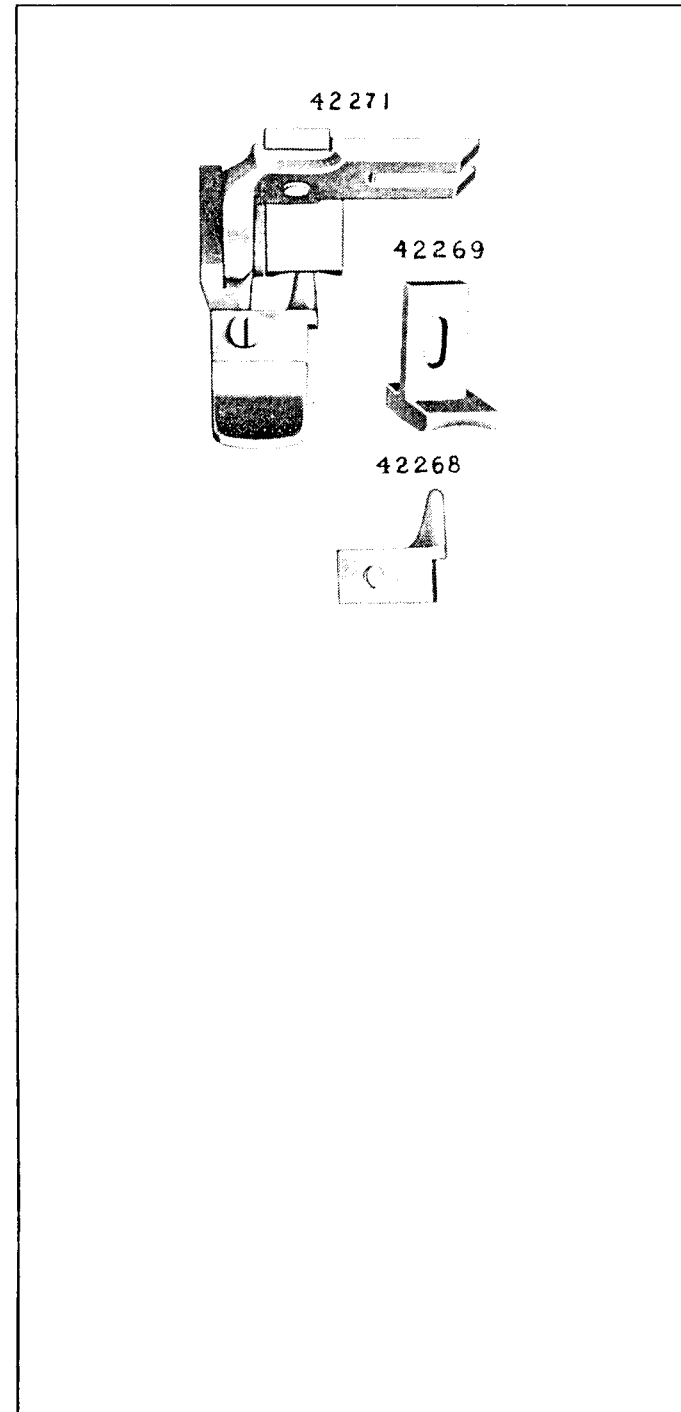
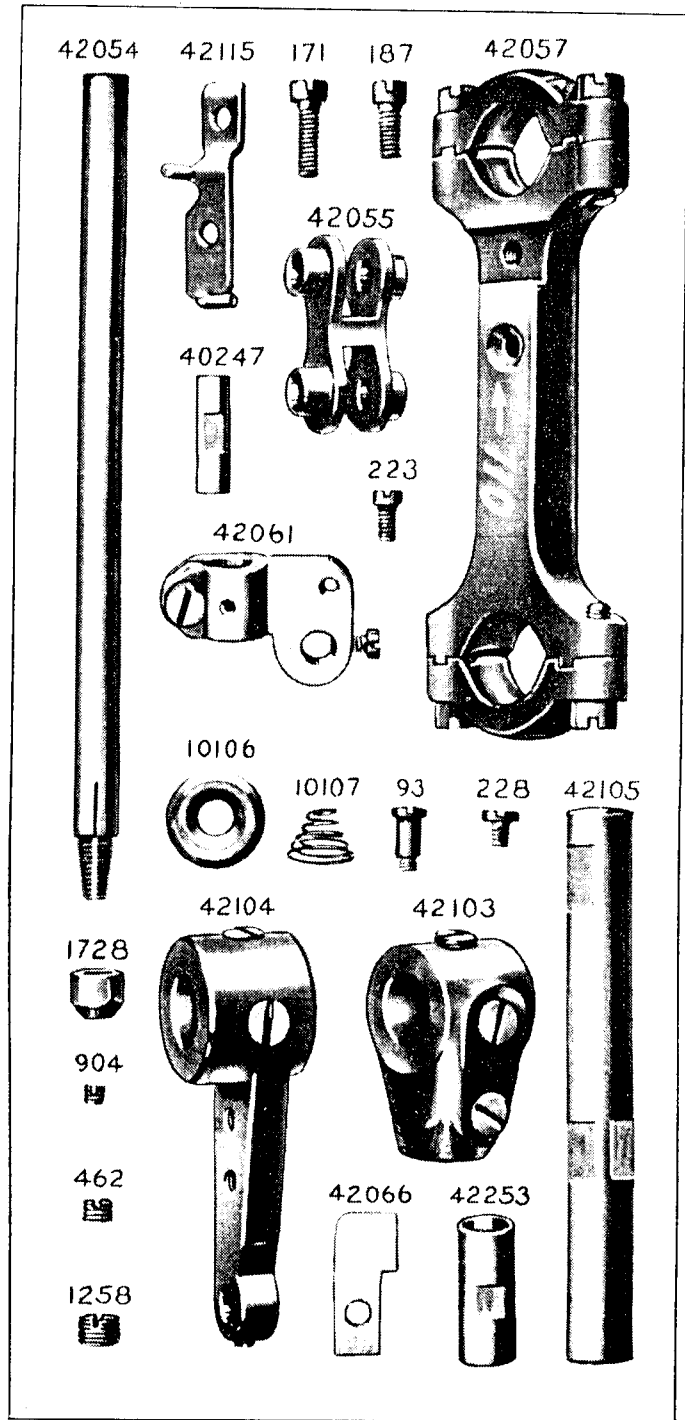

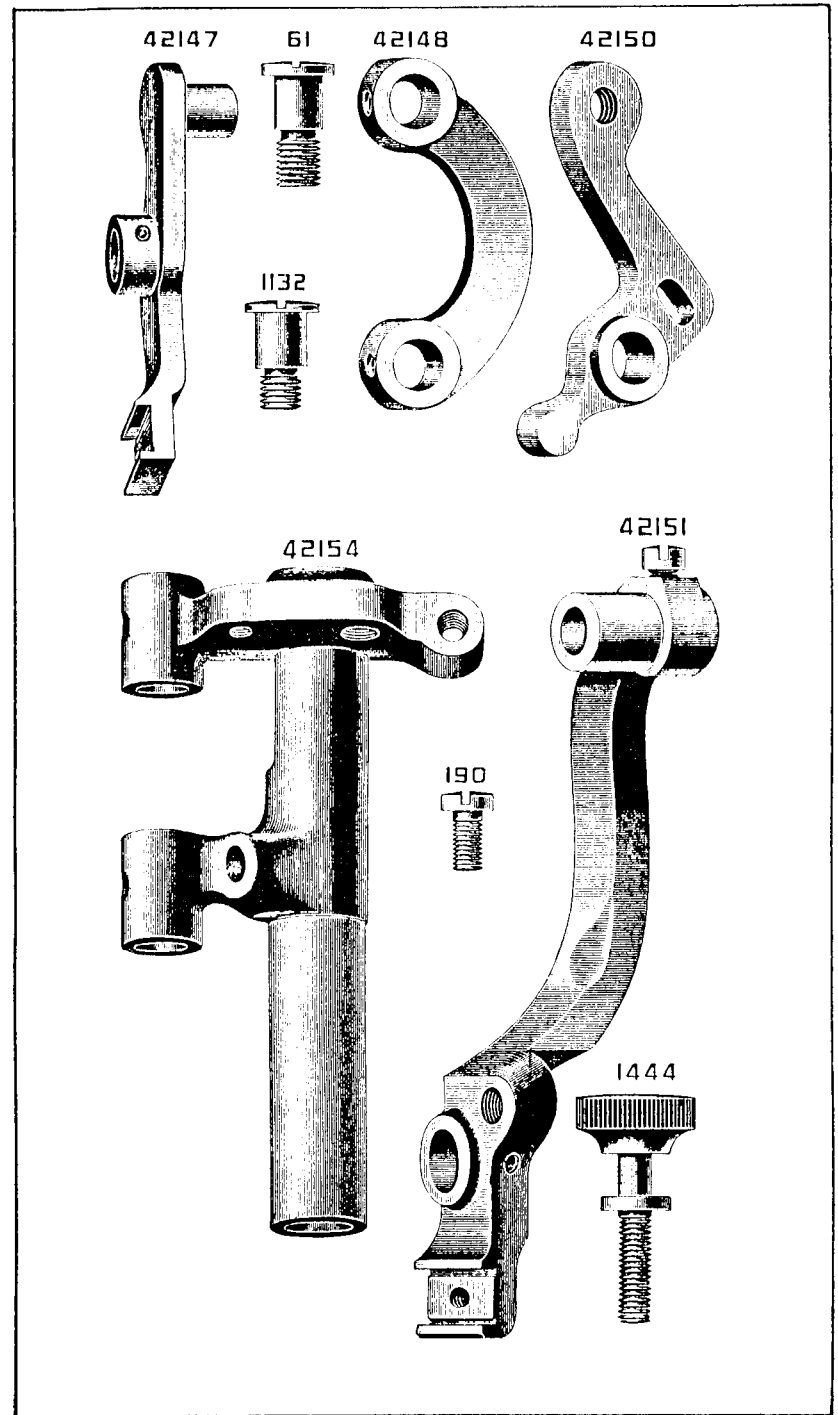
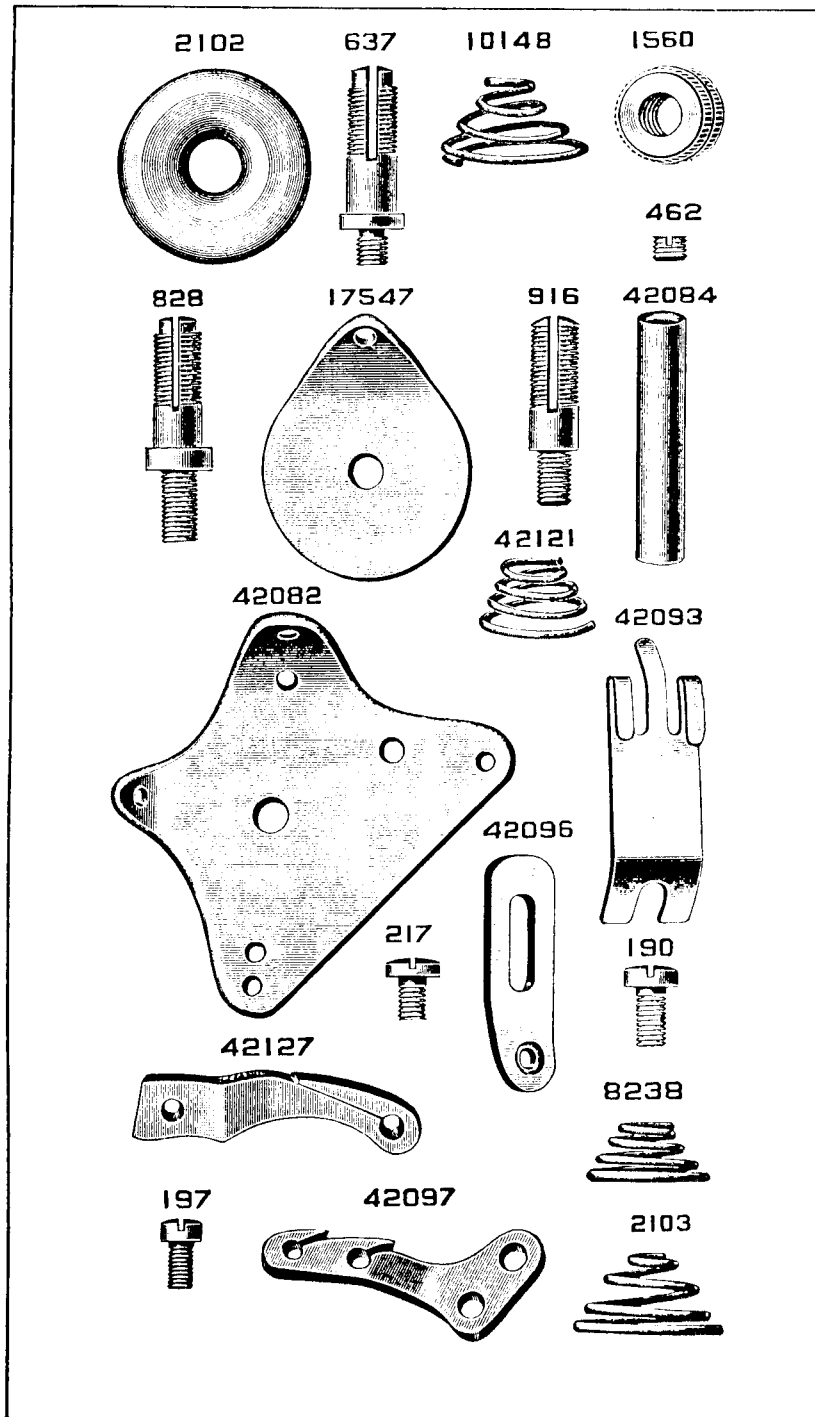

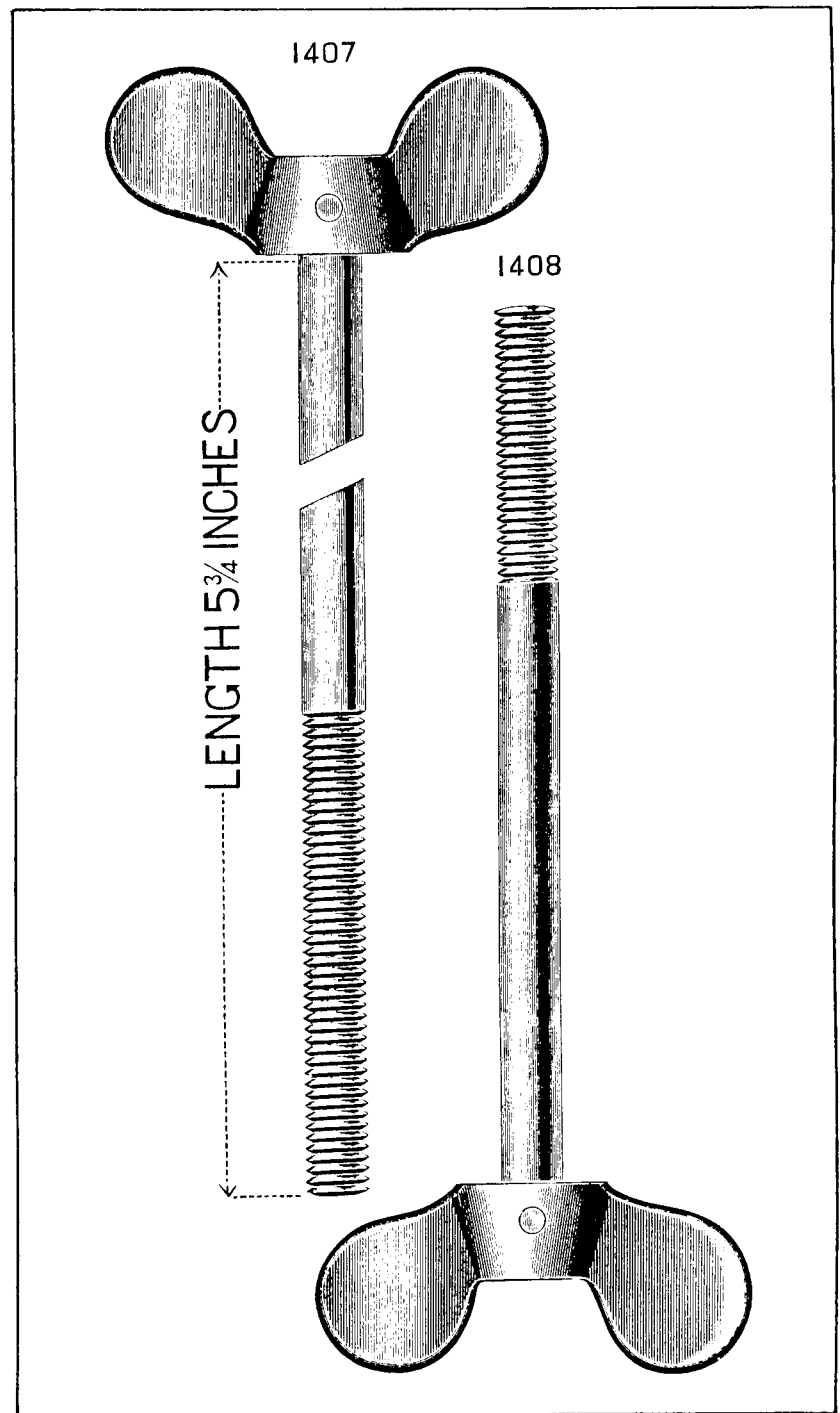
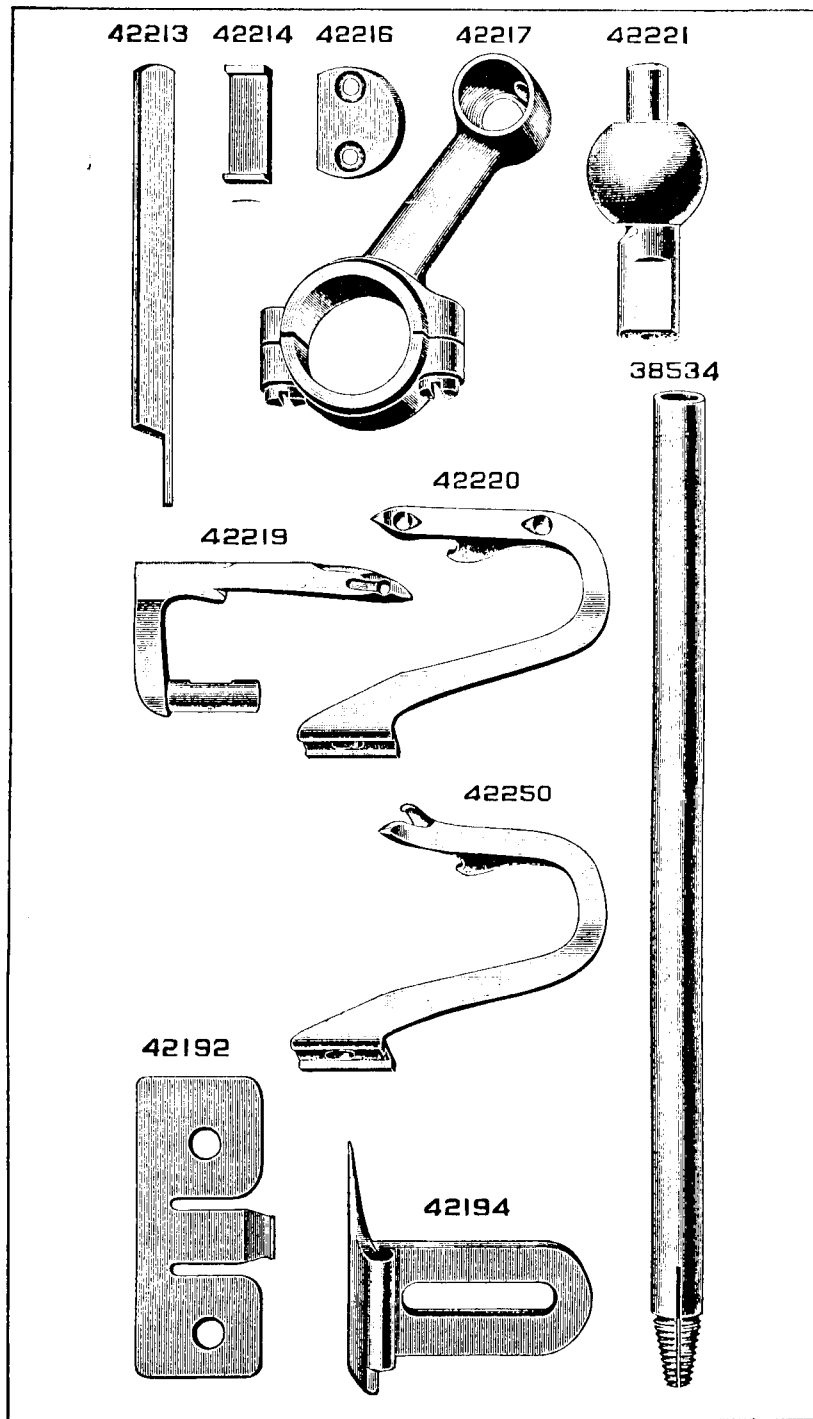

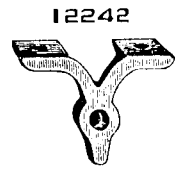
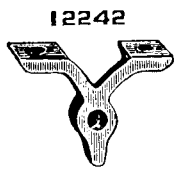

42143

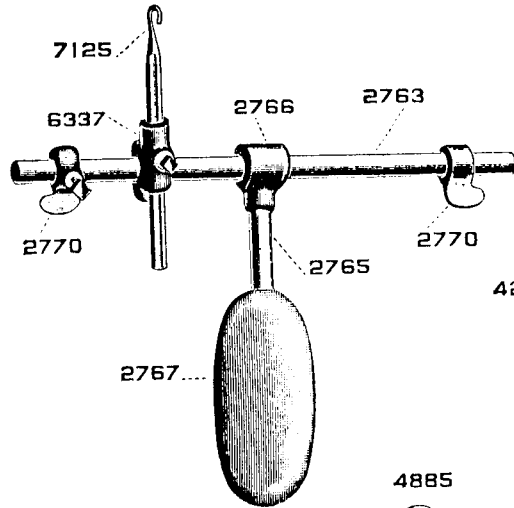

42142



42086

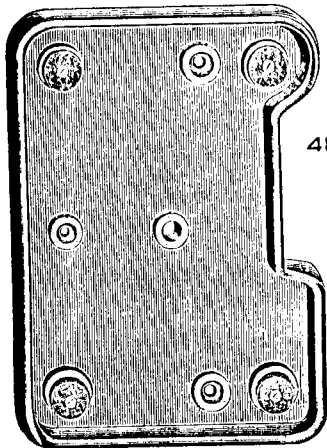

4881

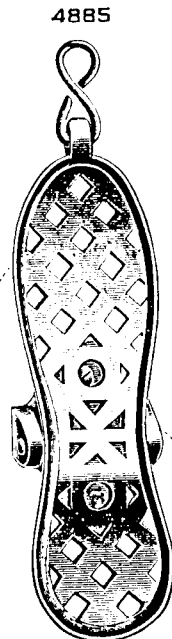

4884

41329

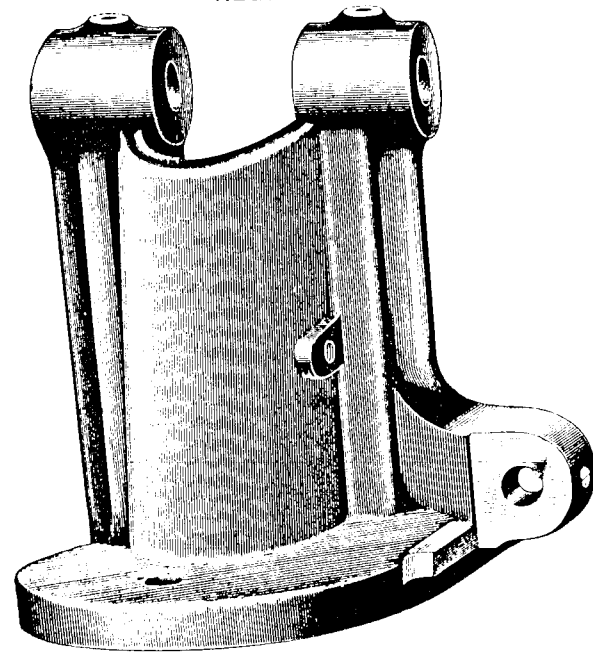

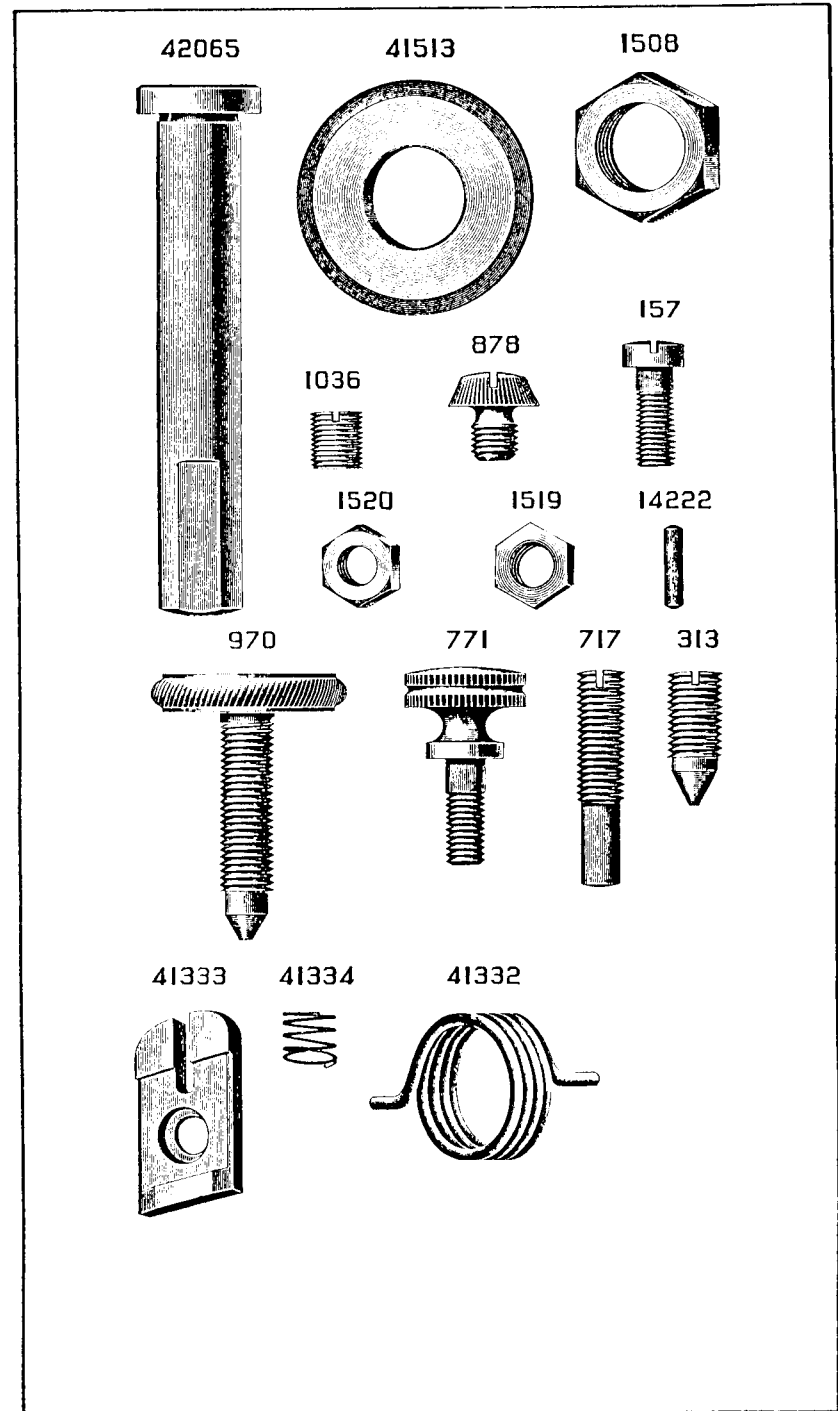
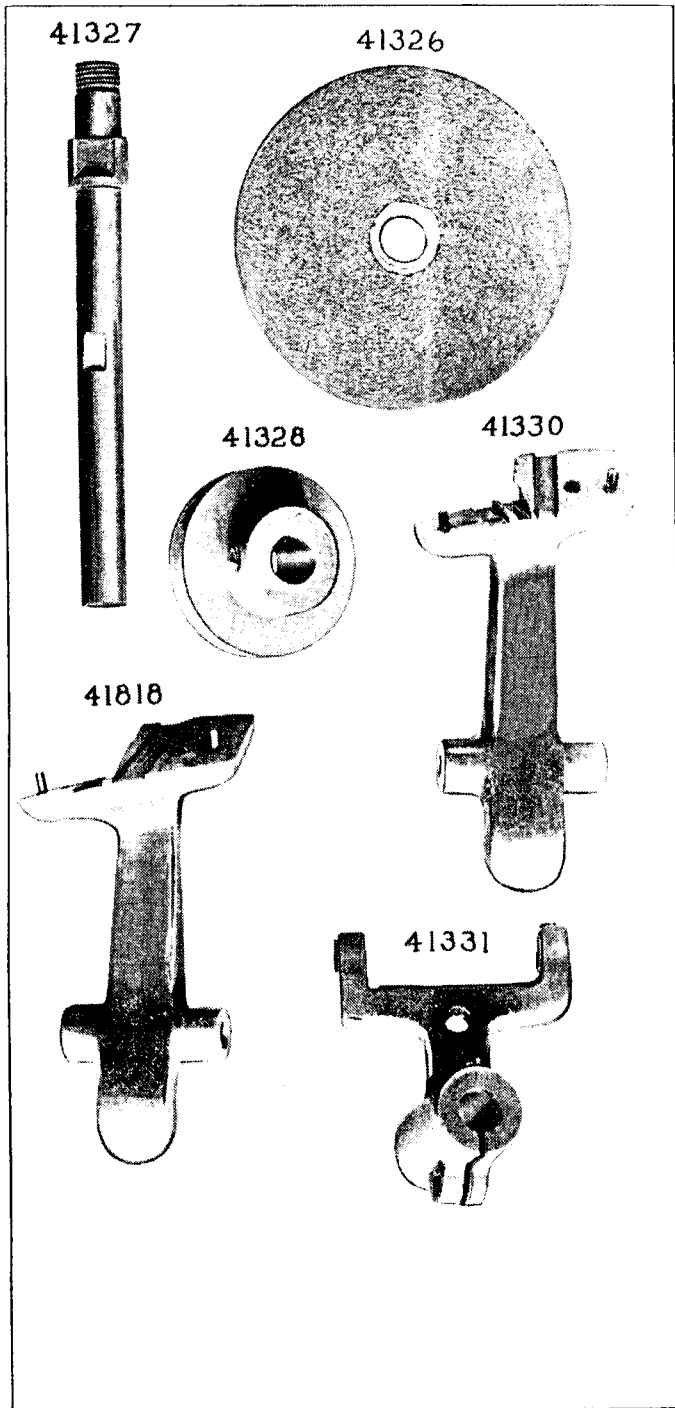

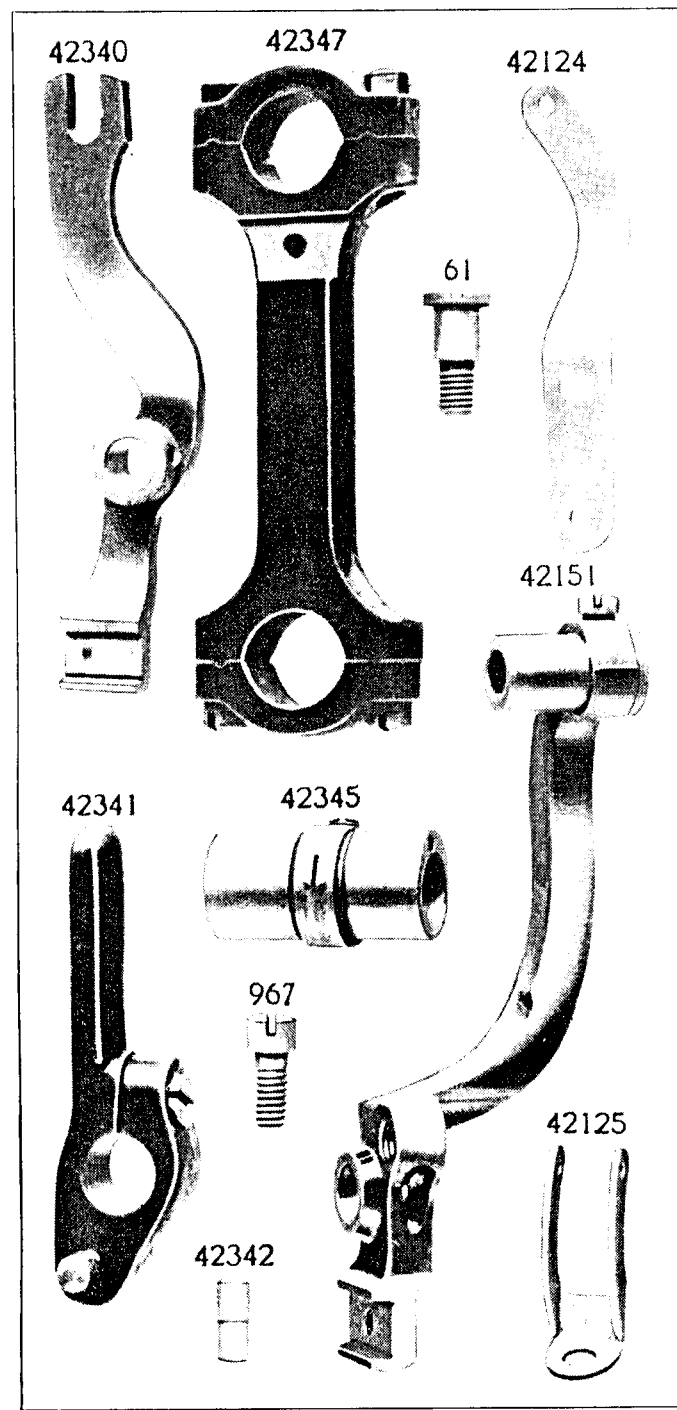
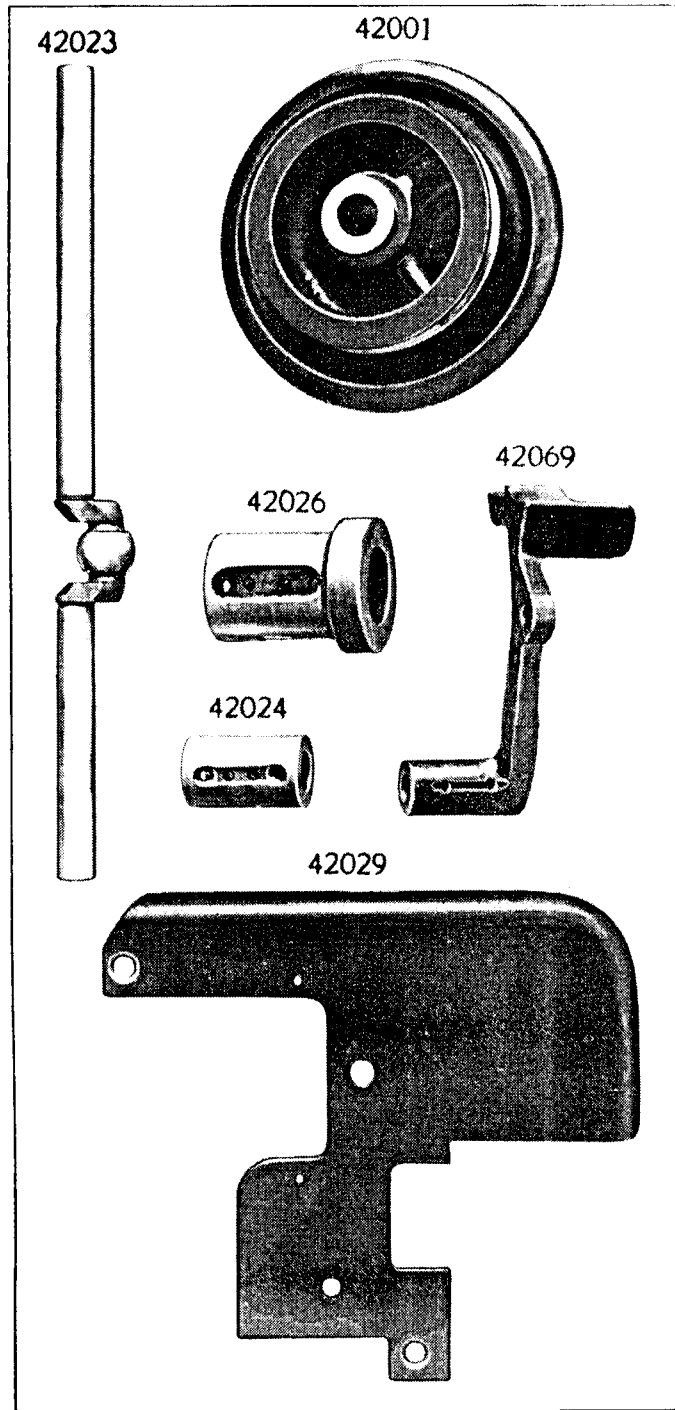

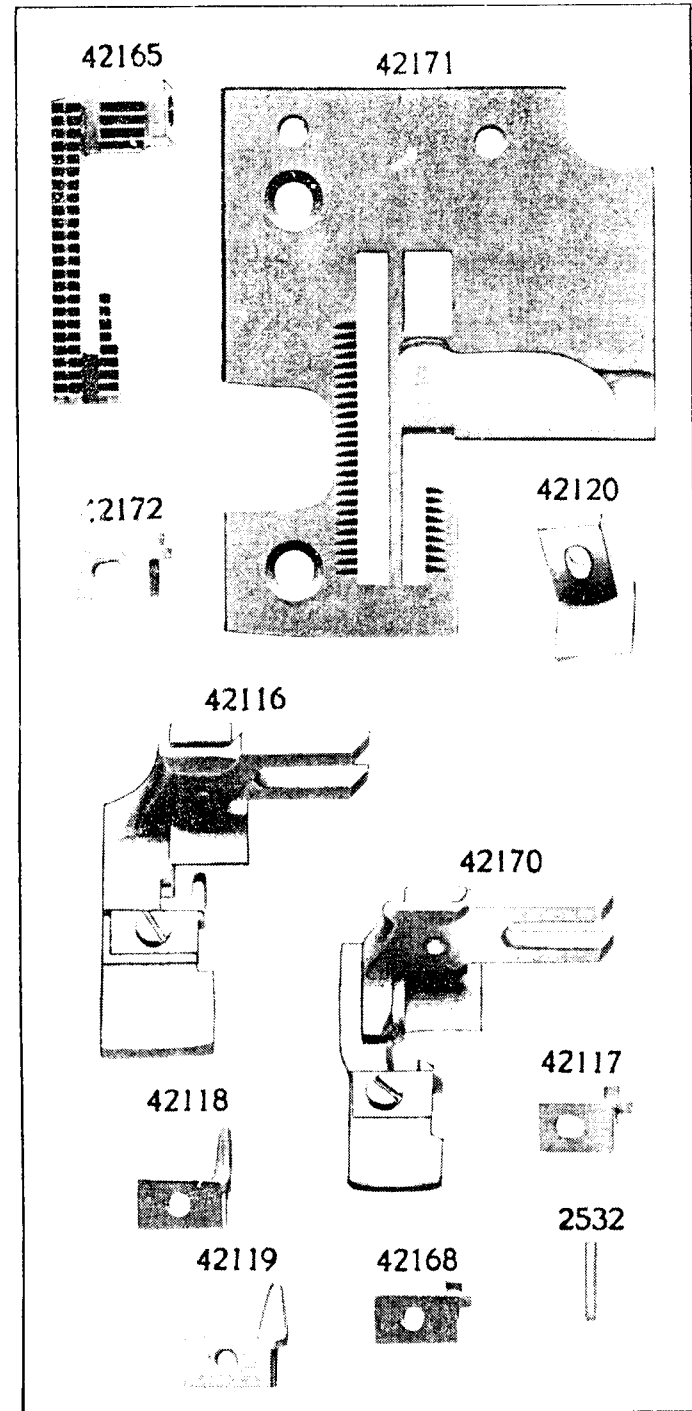
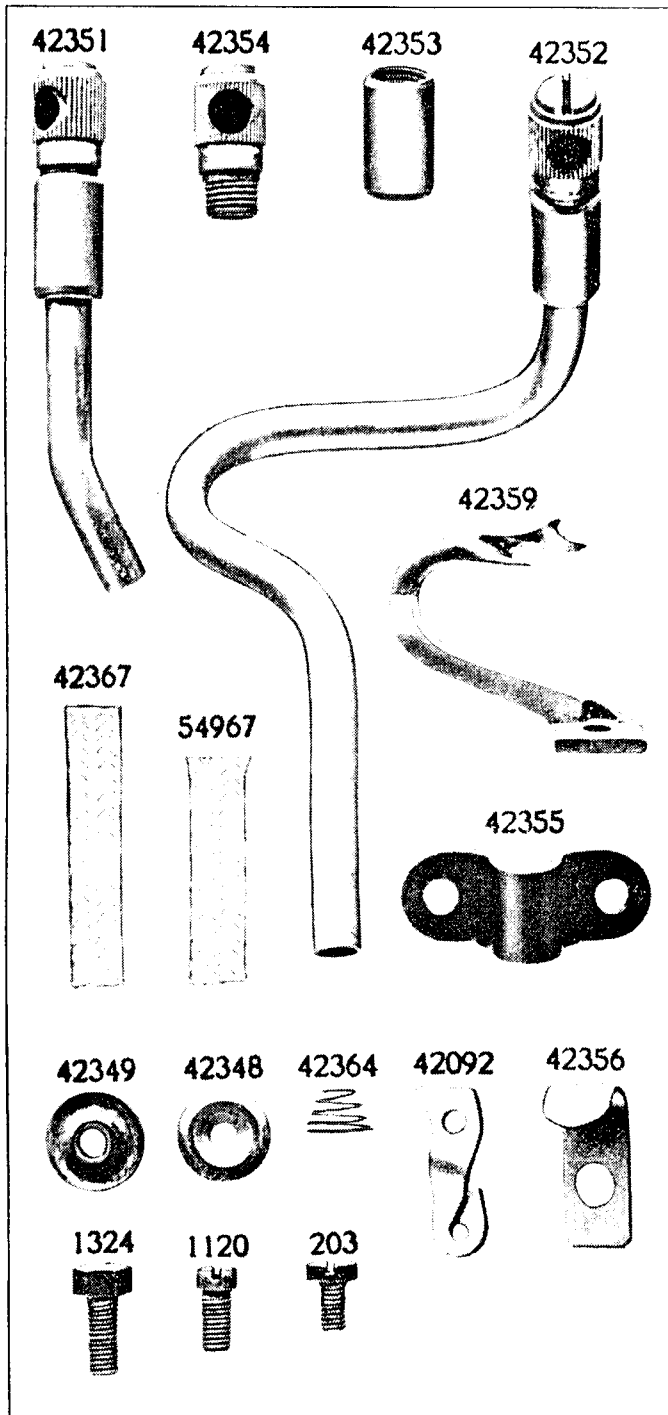

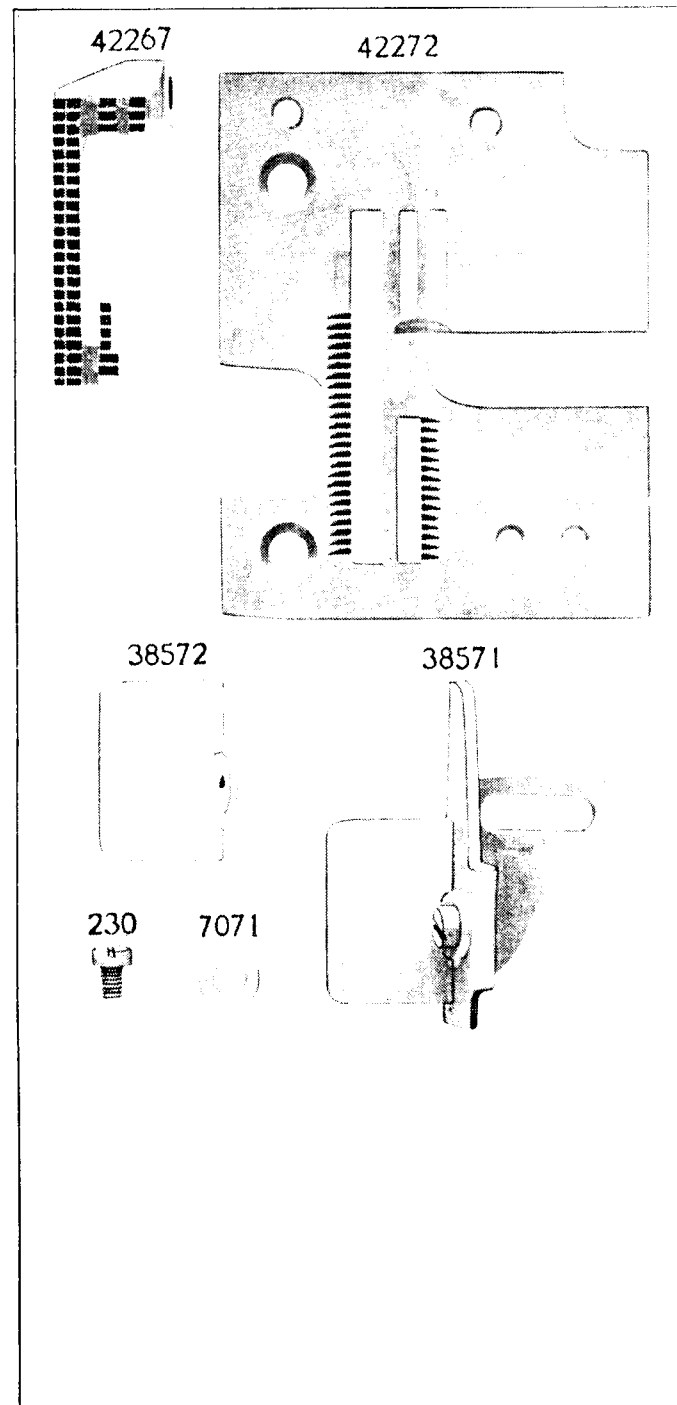
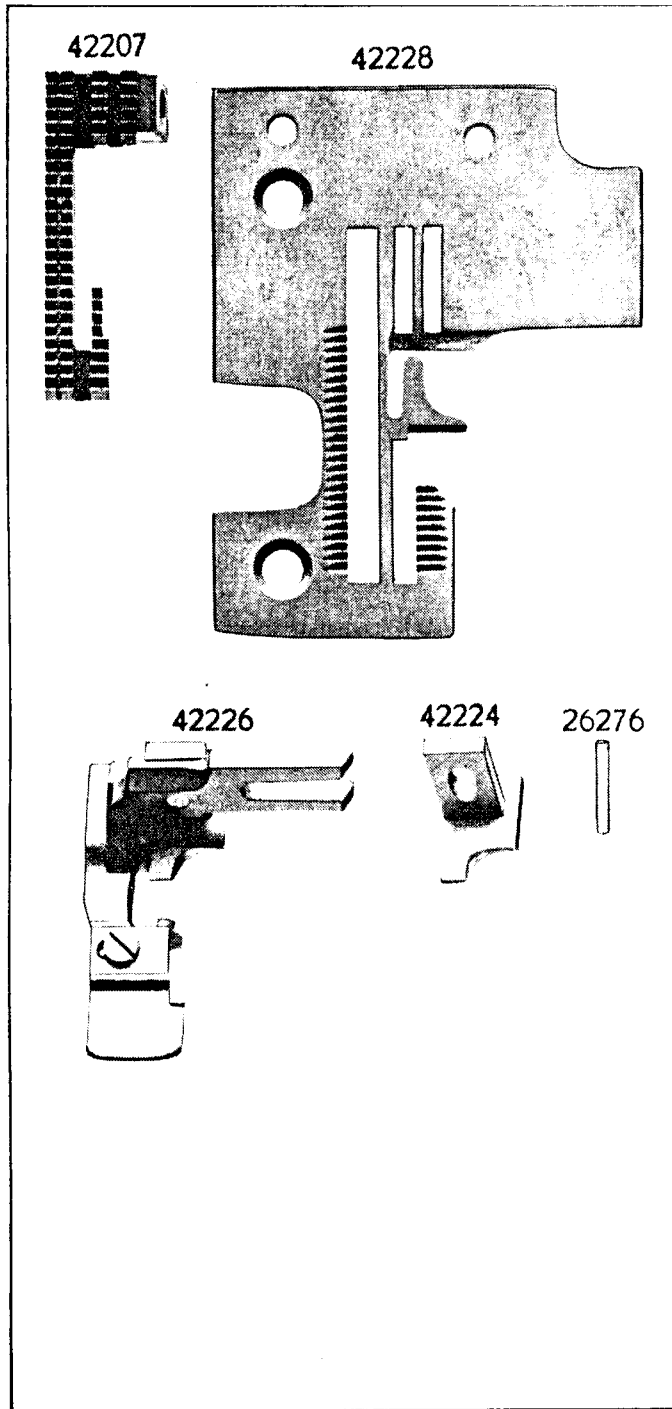

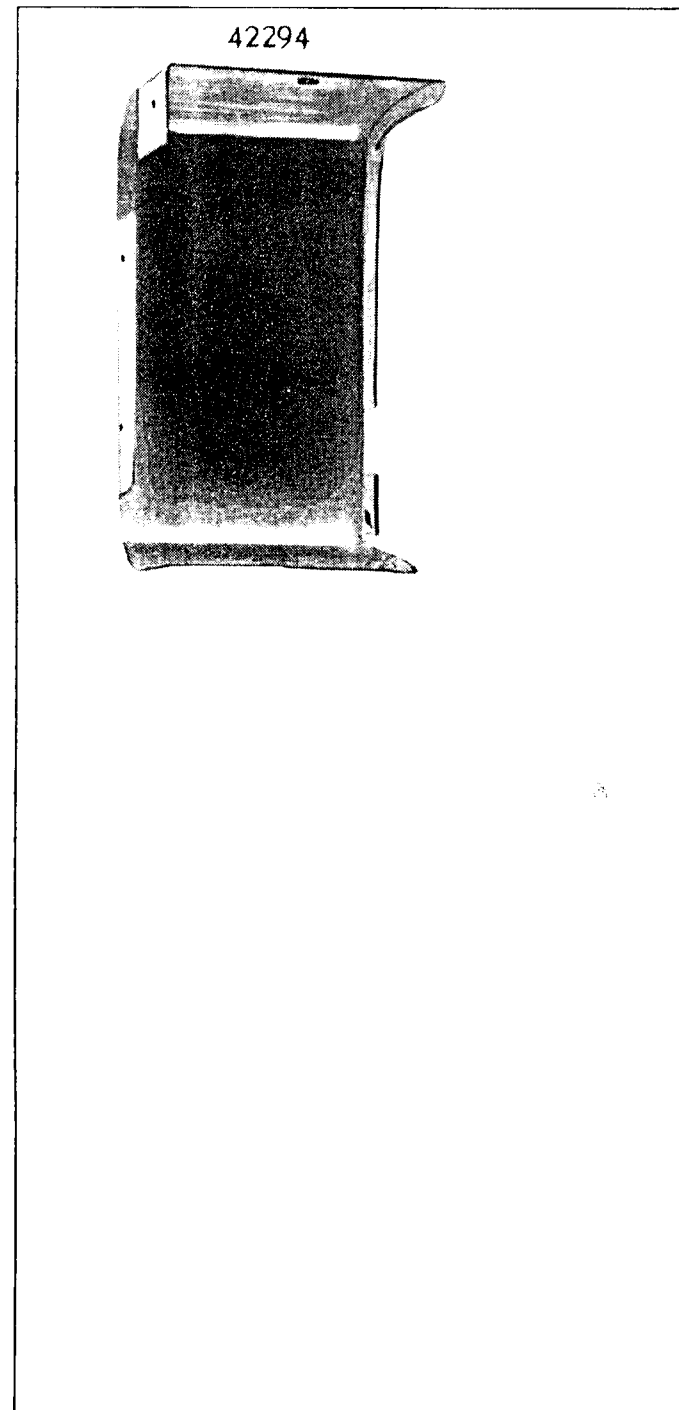
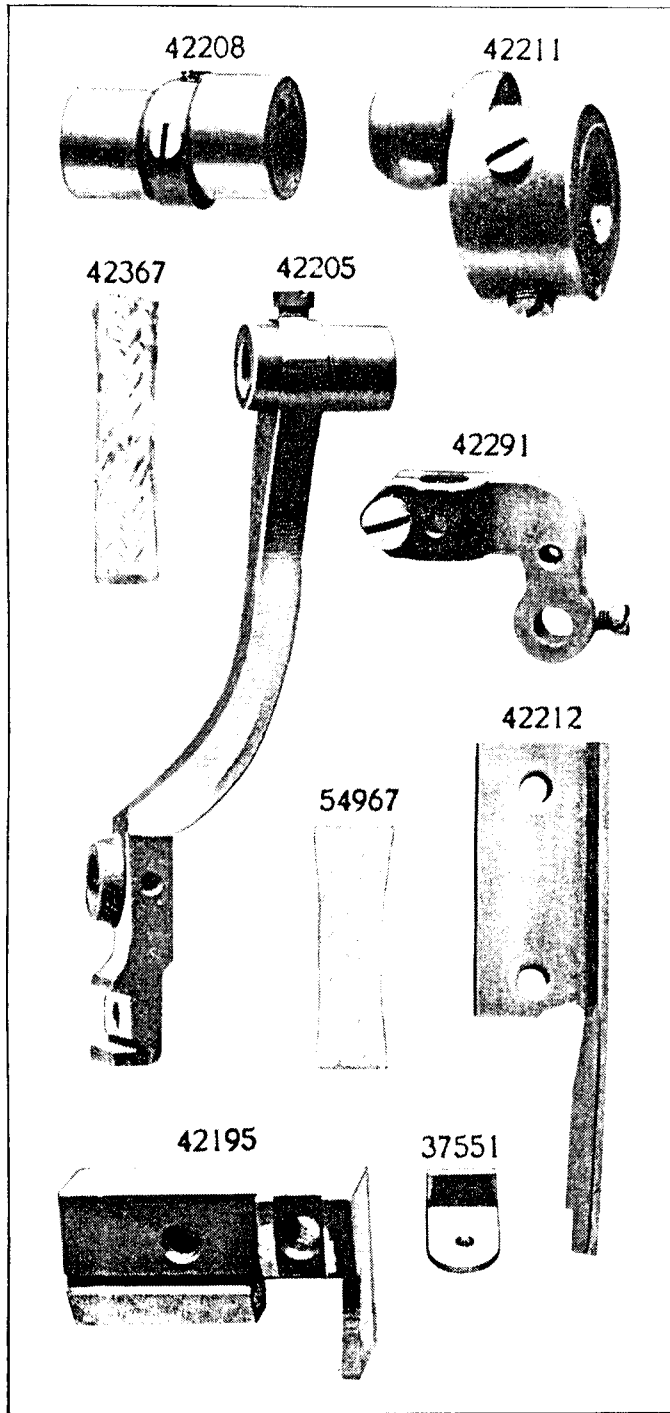

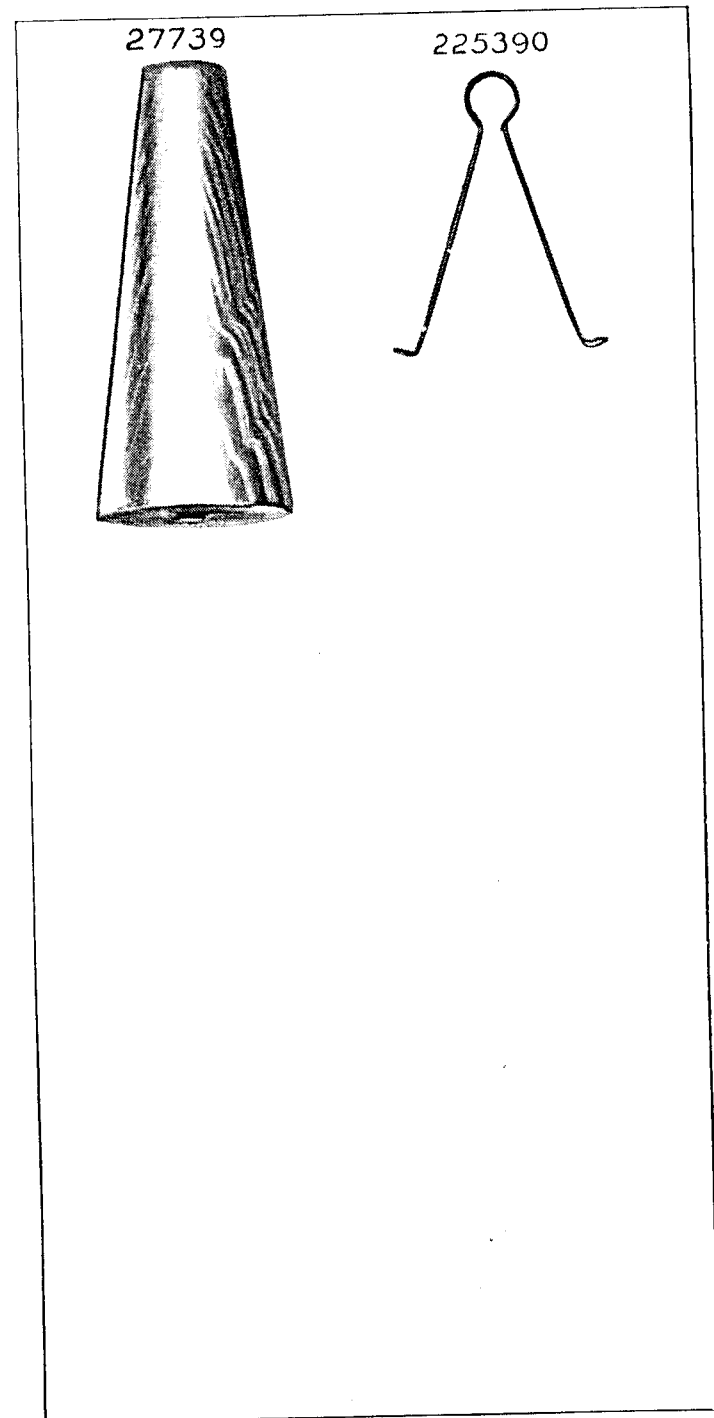
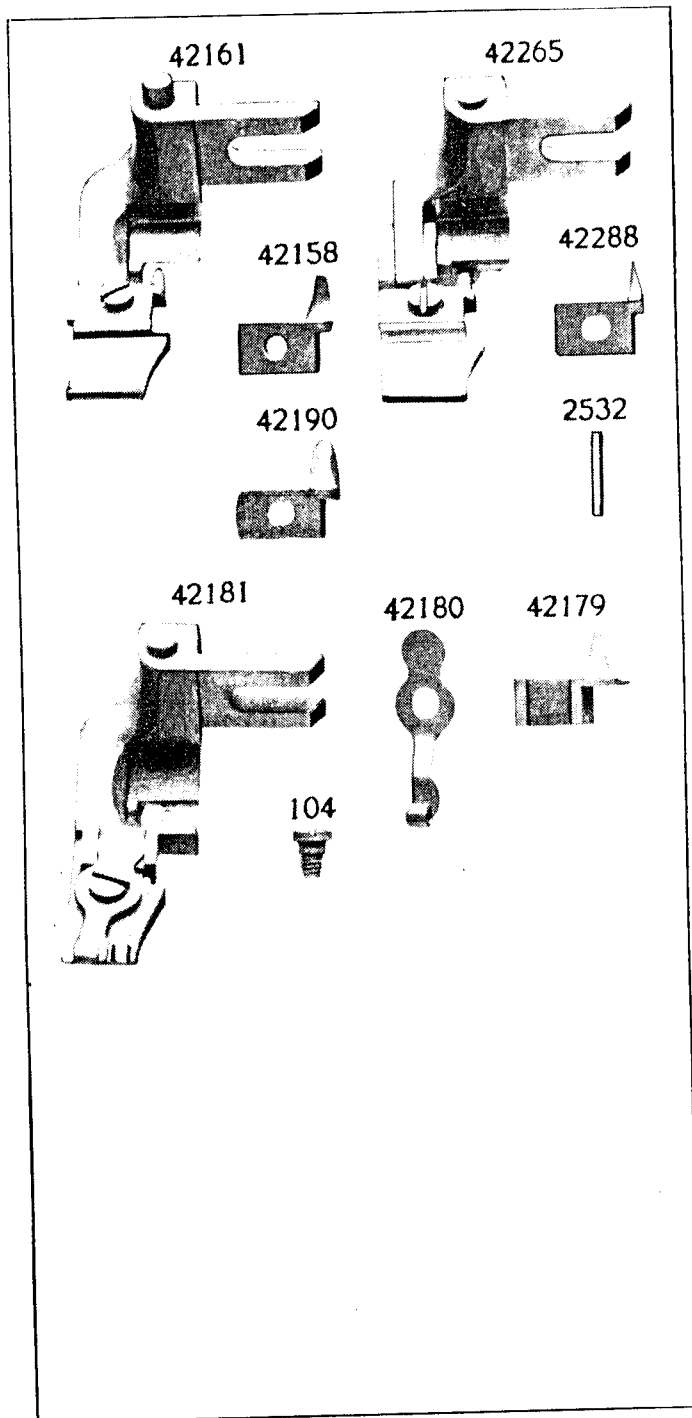

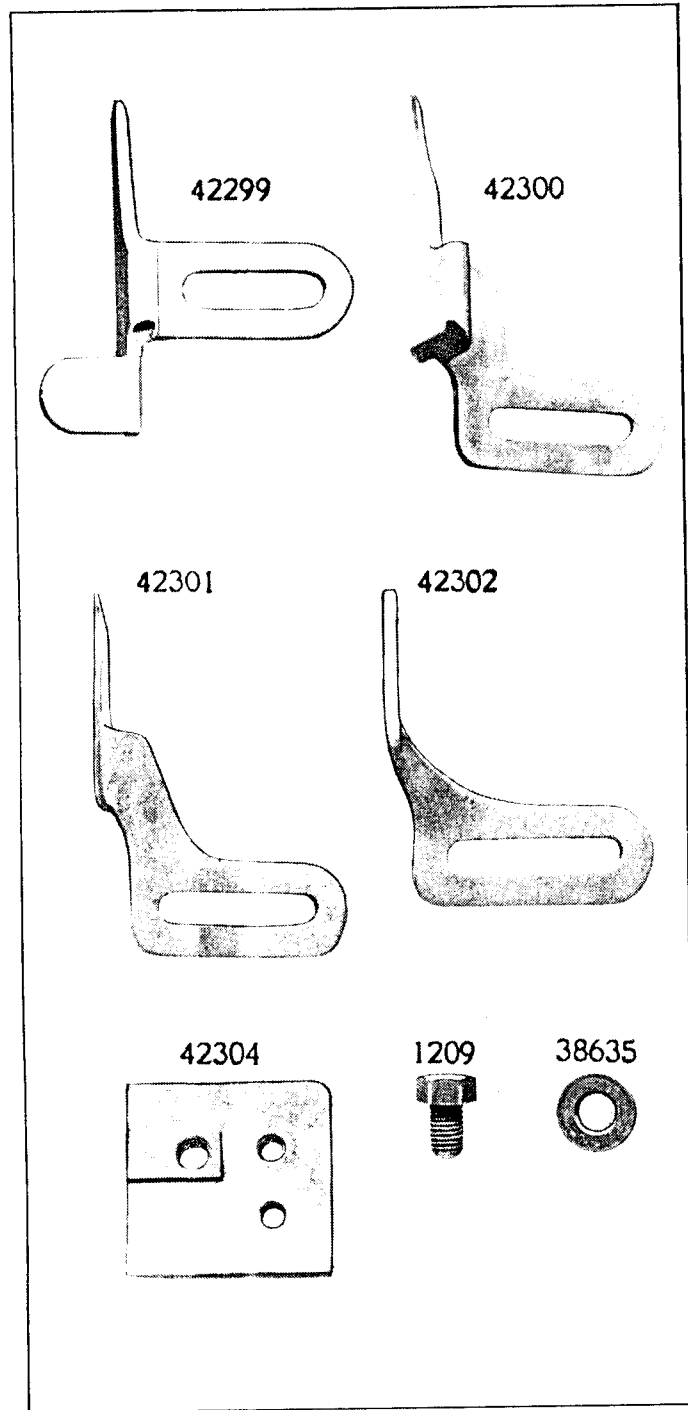
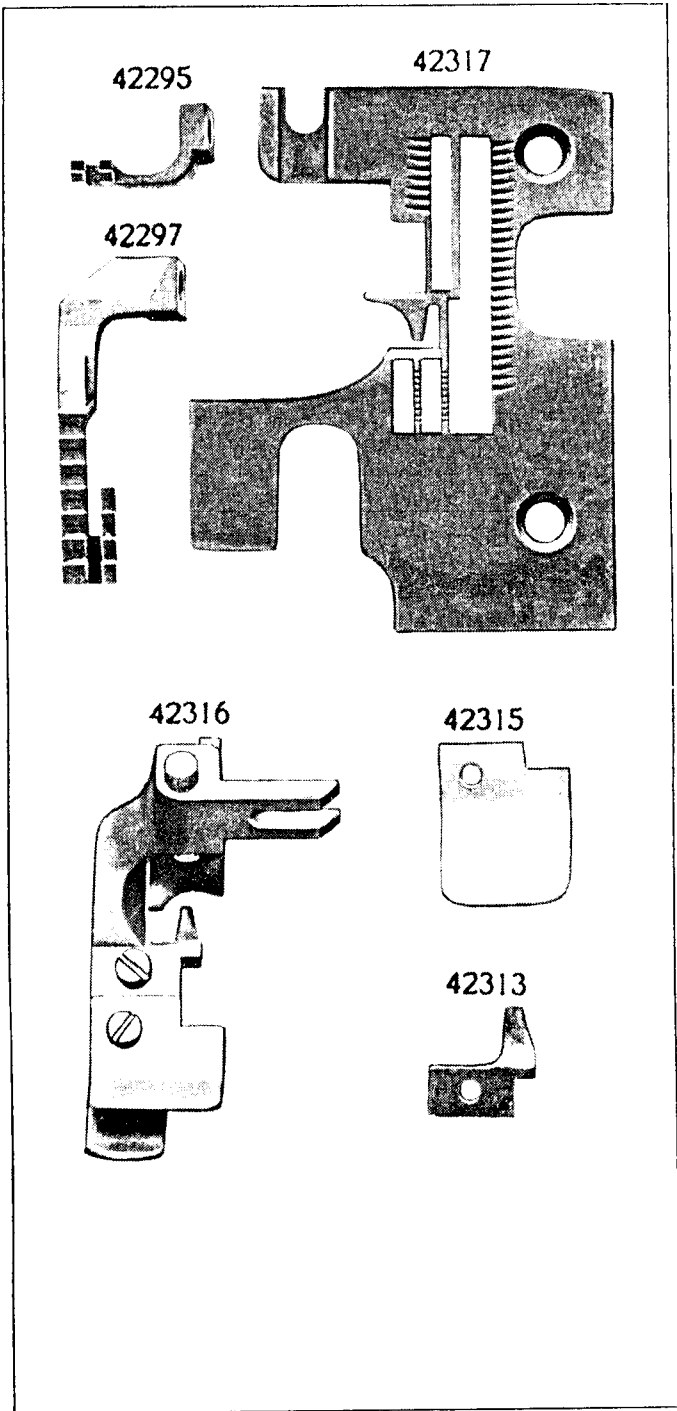

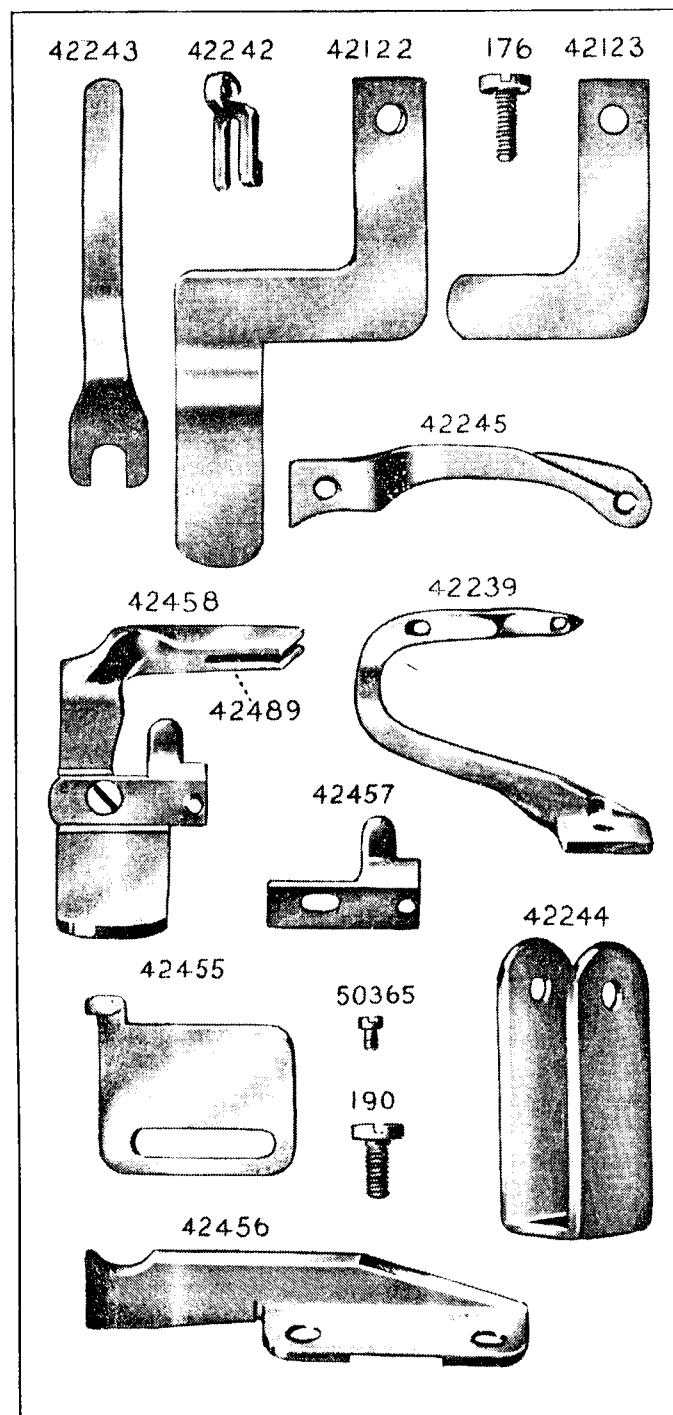
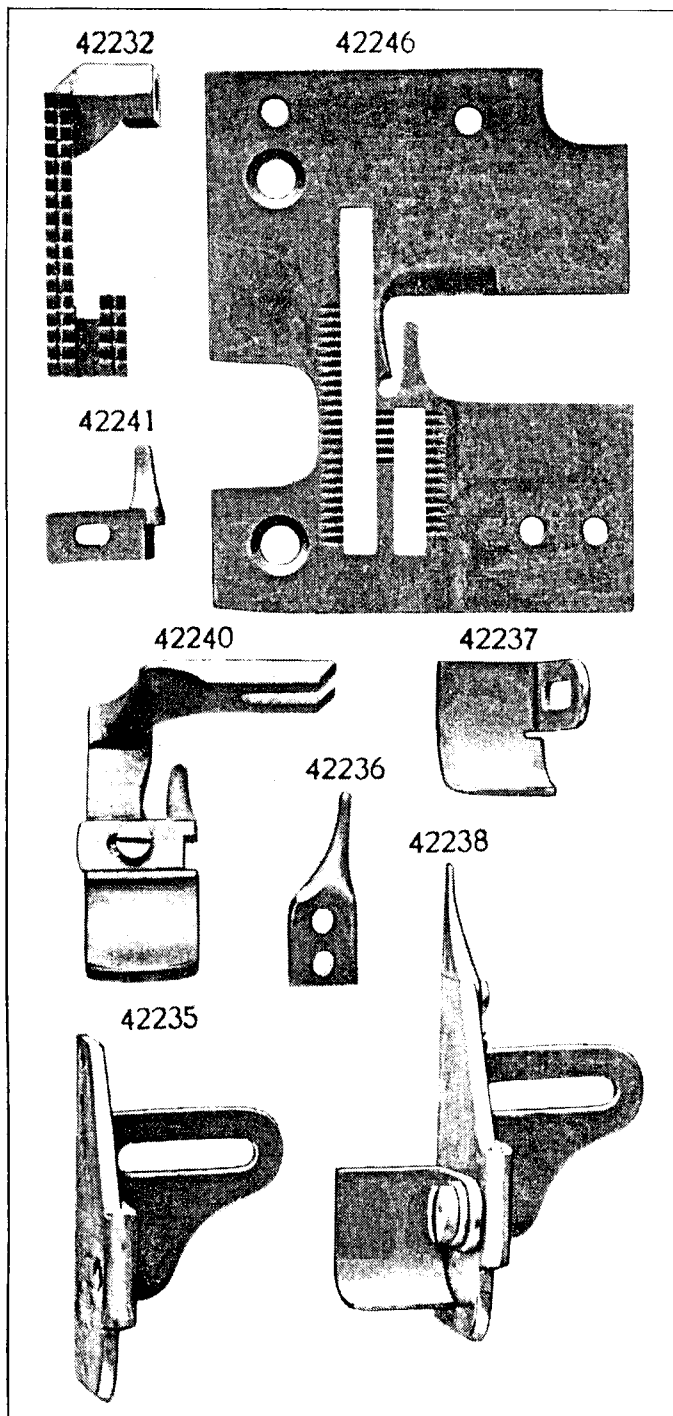

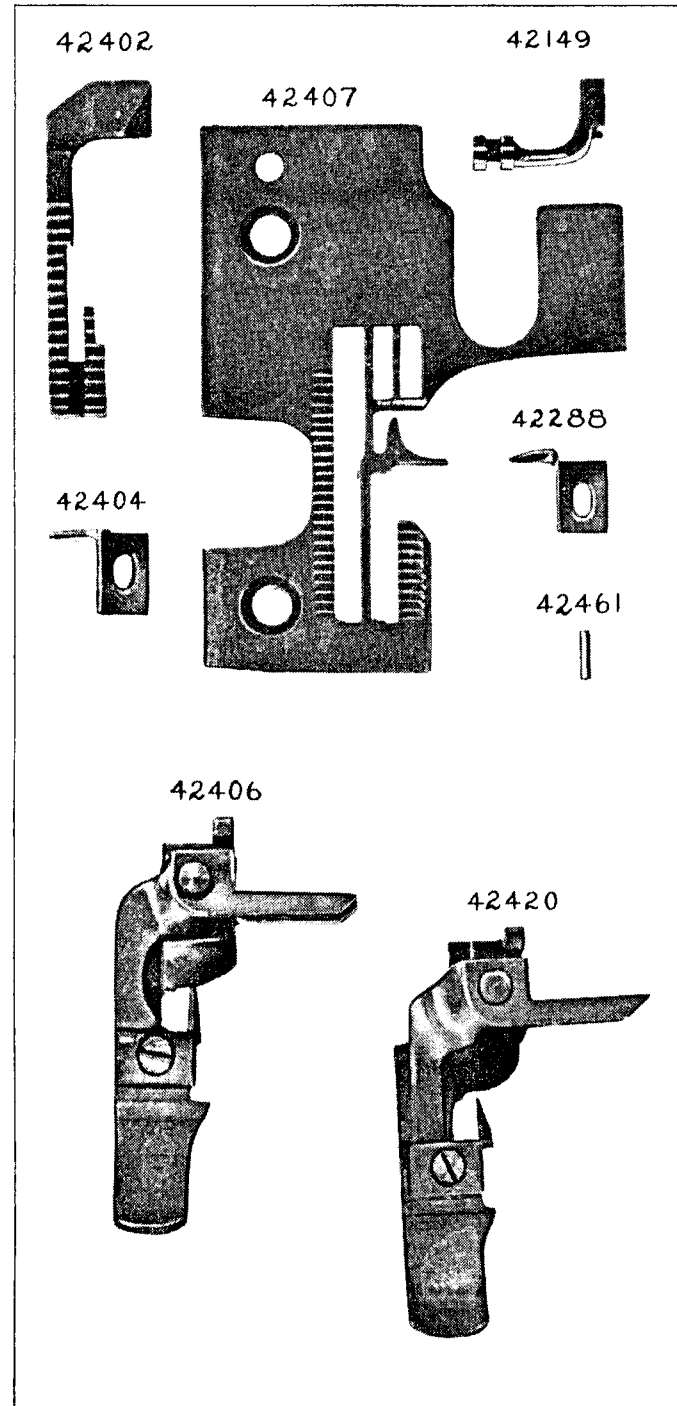
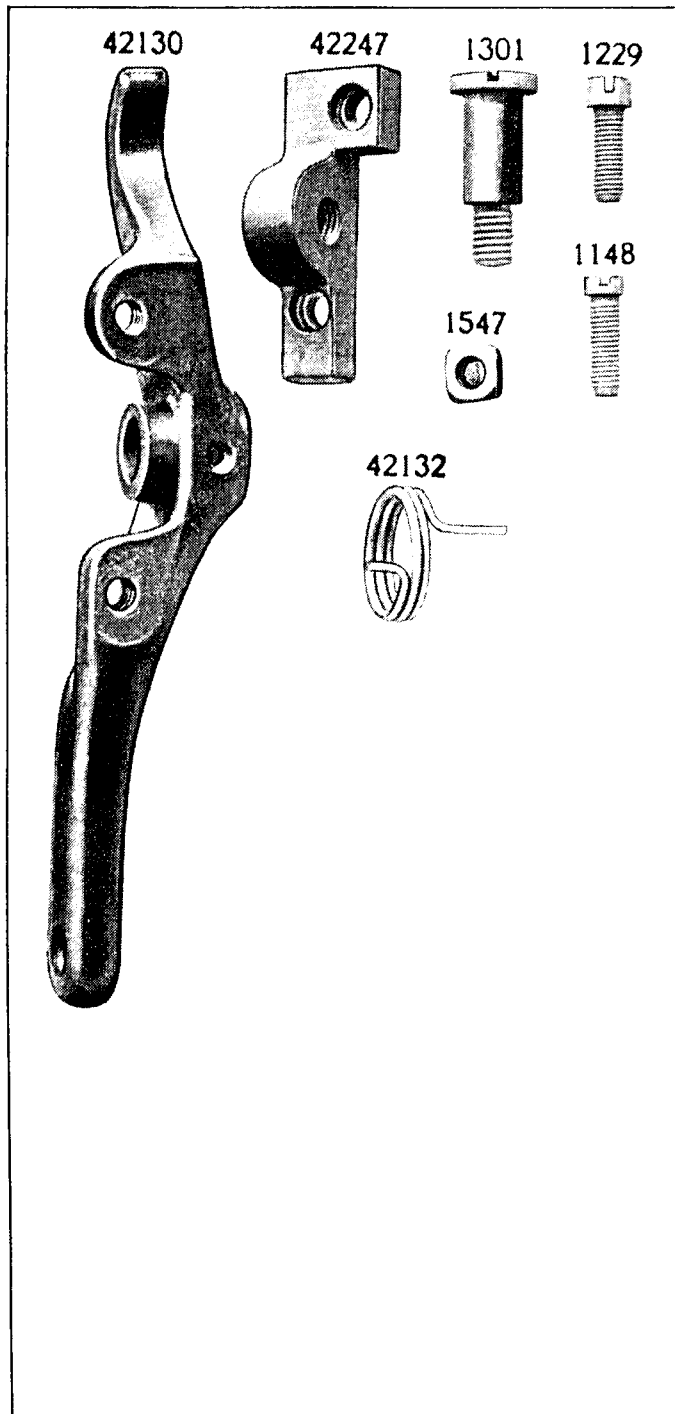

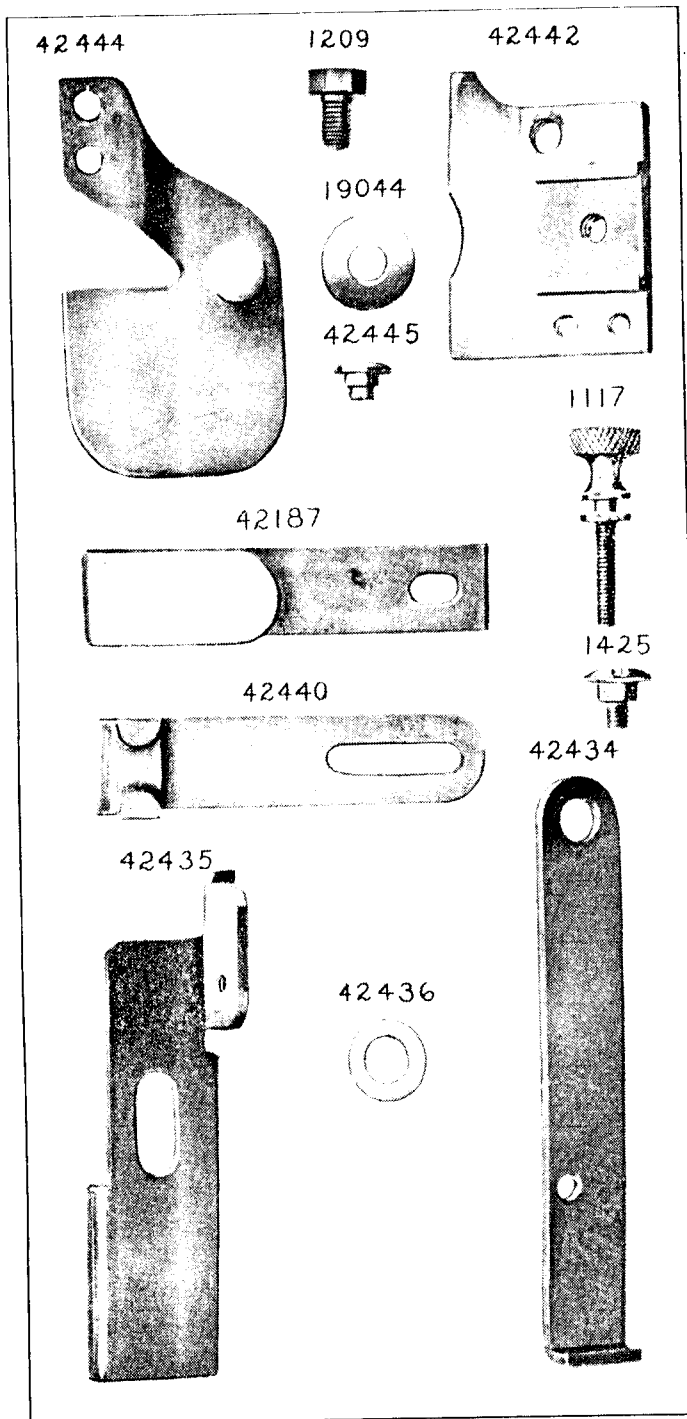
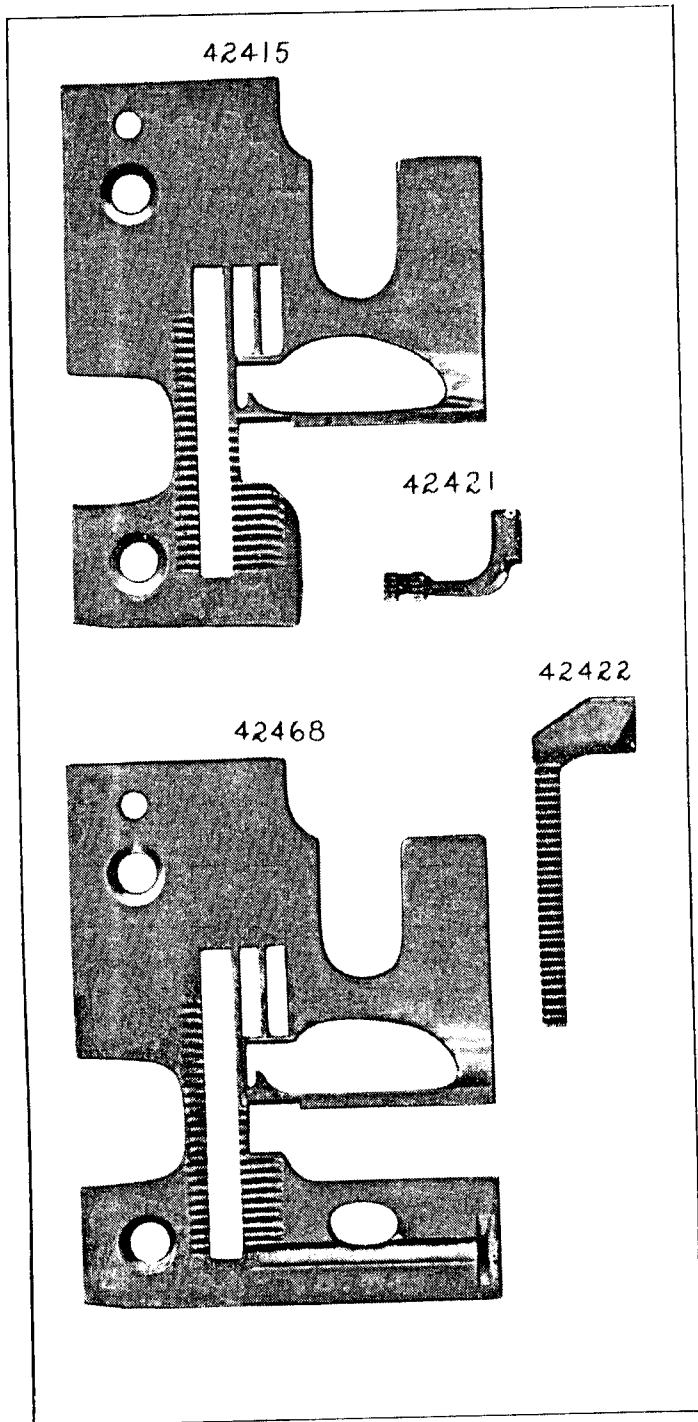

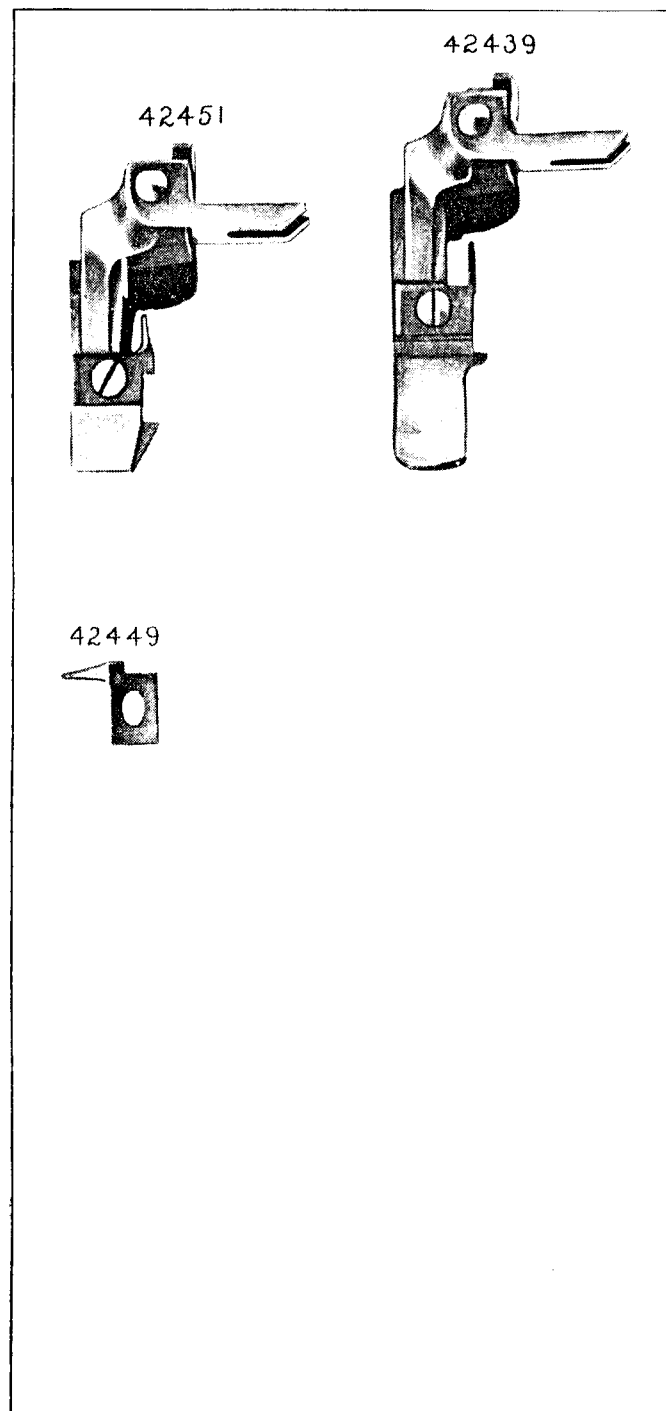
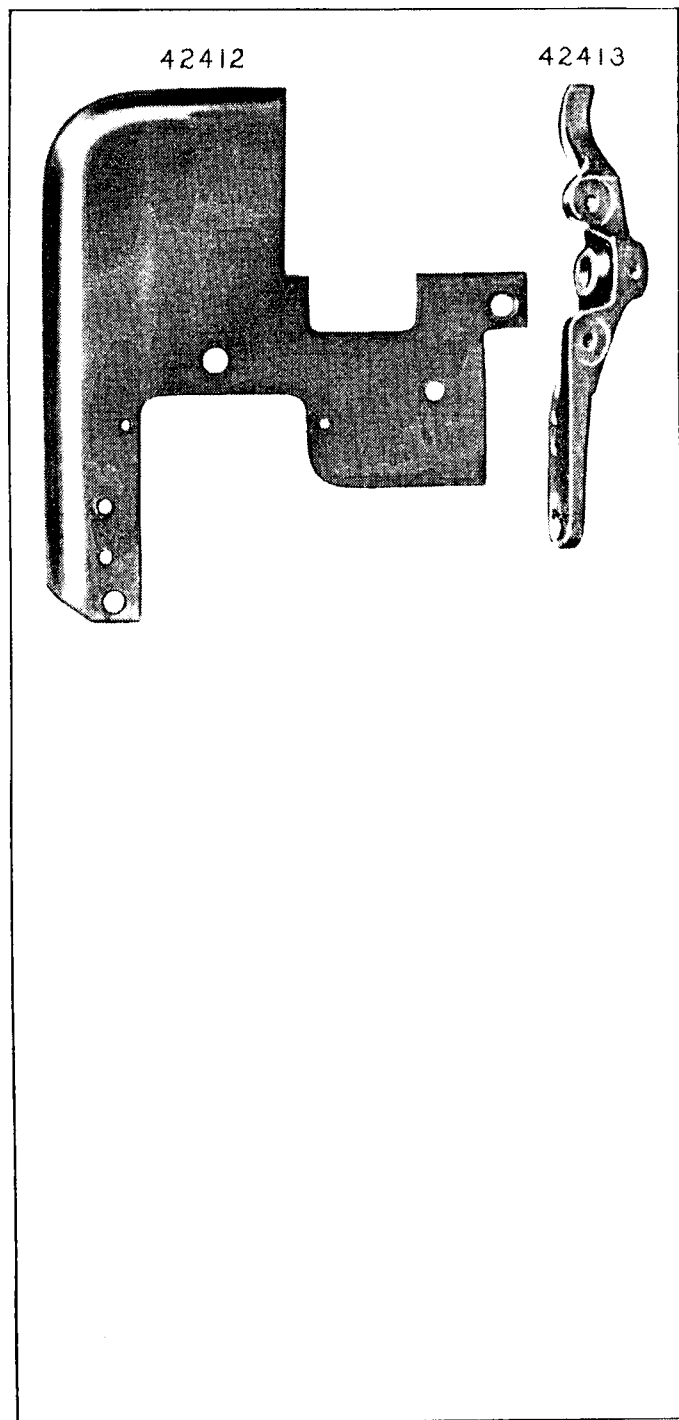

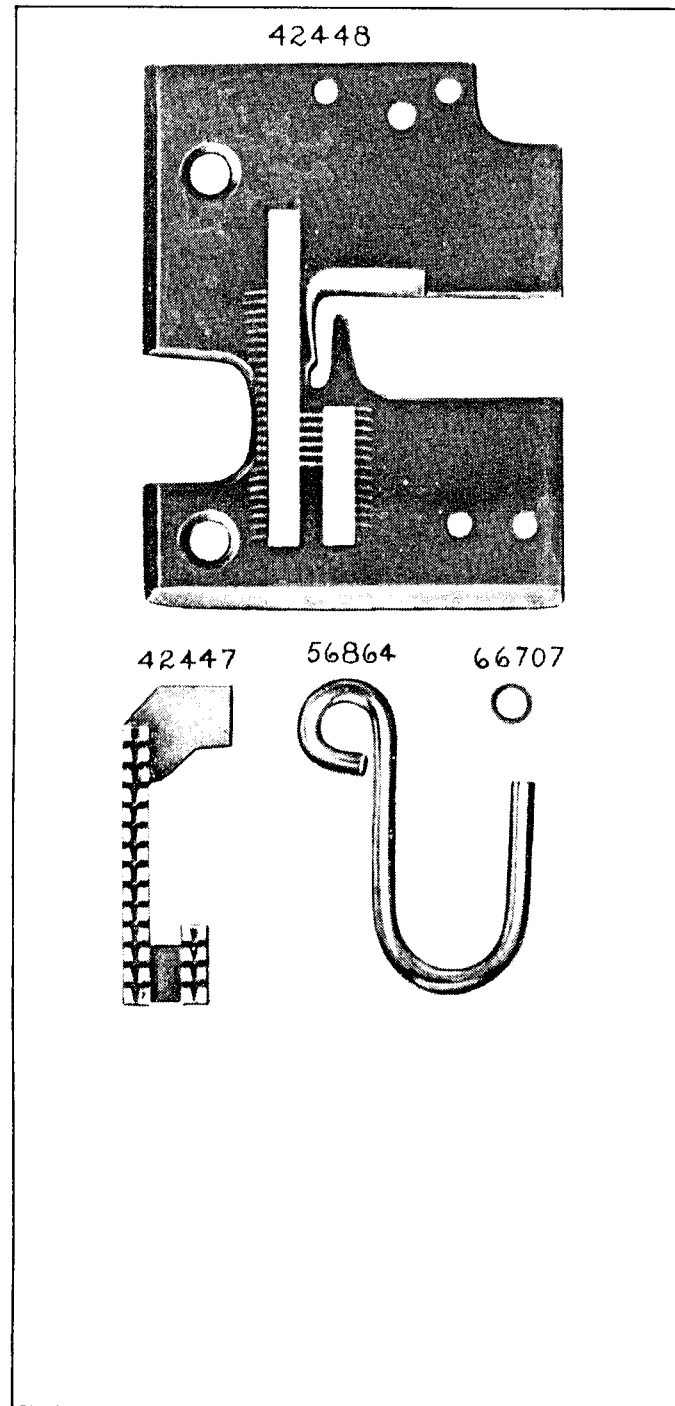
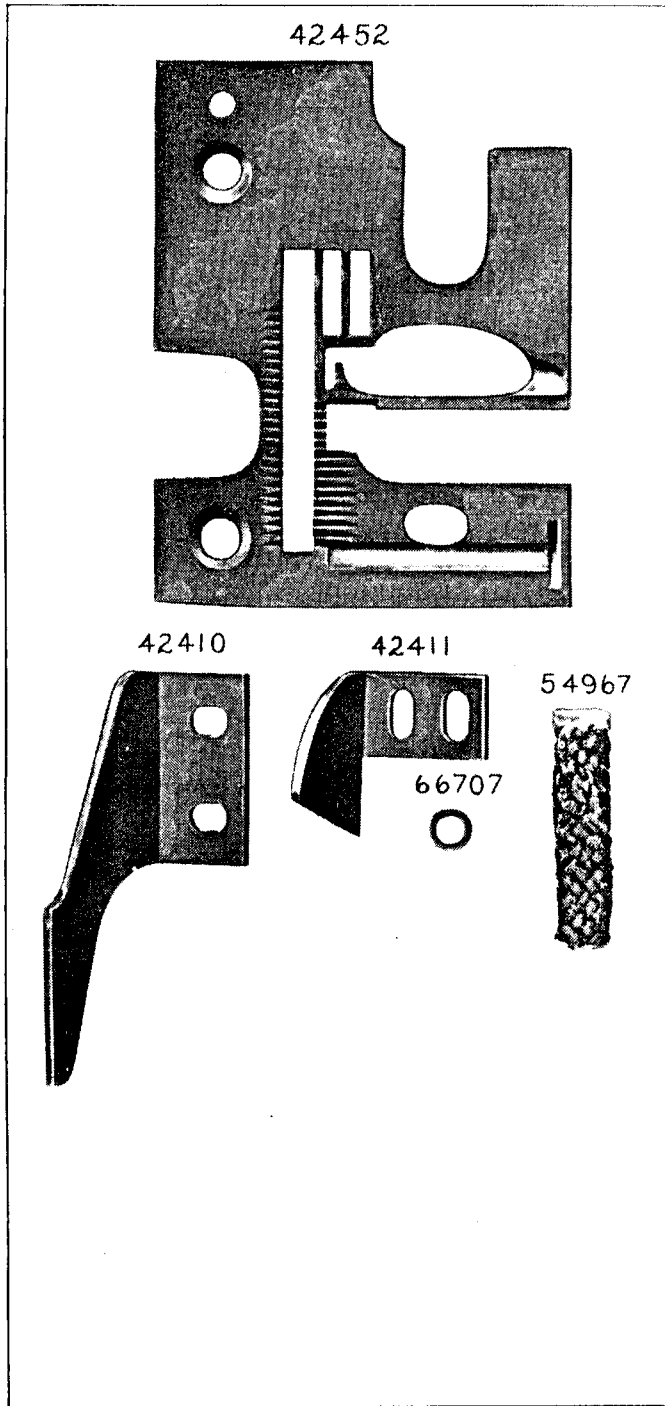

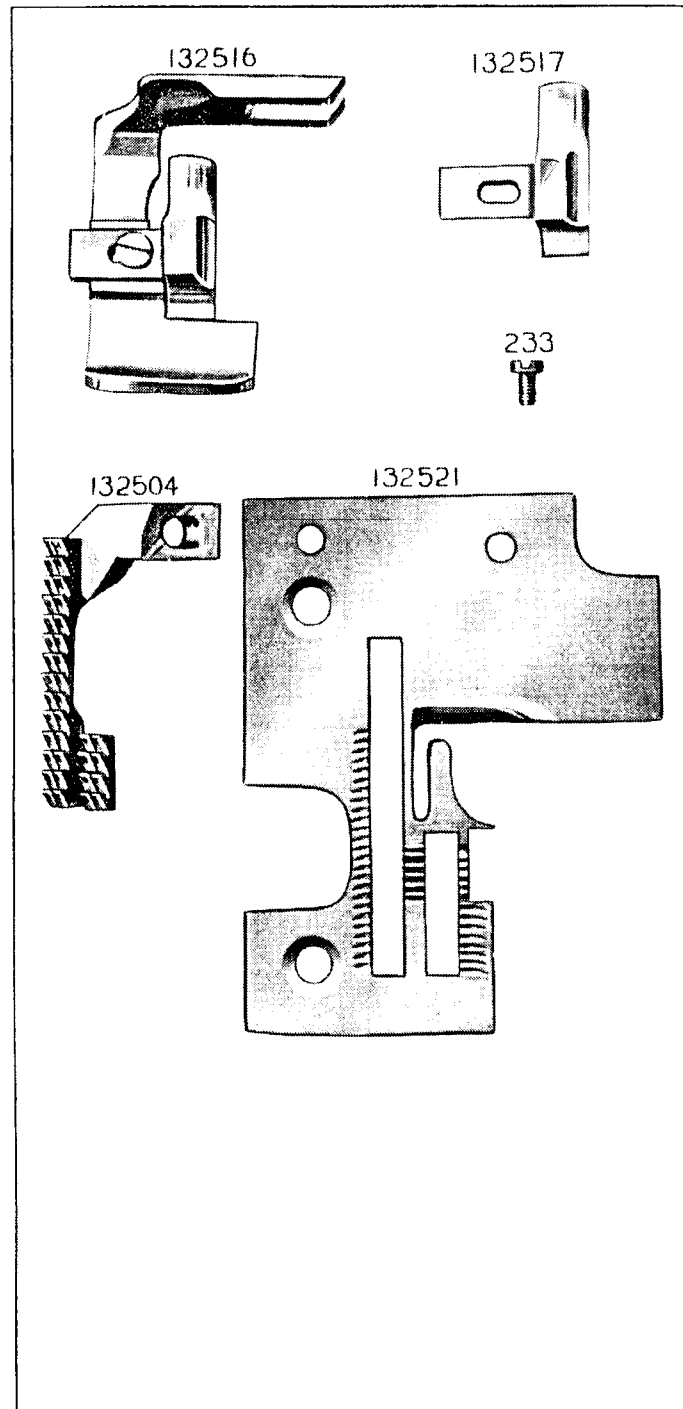
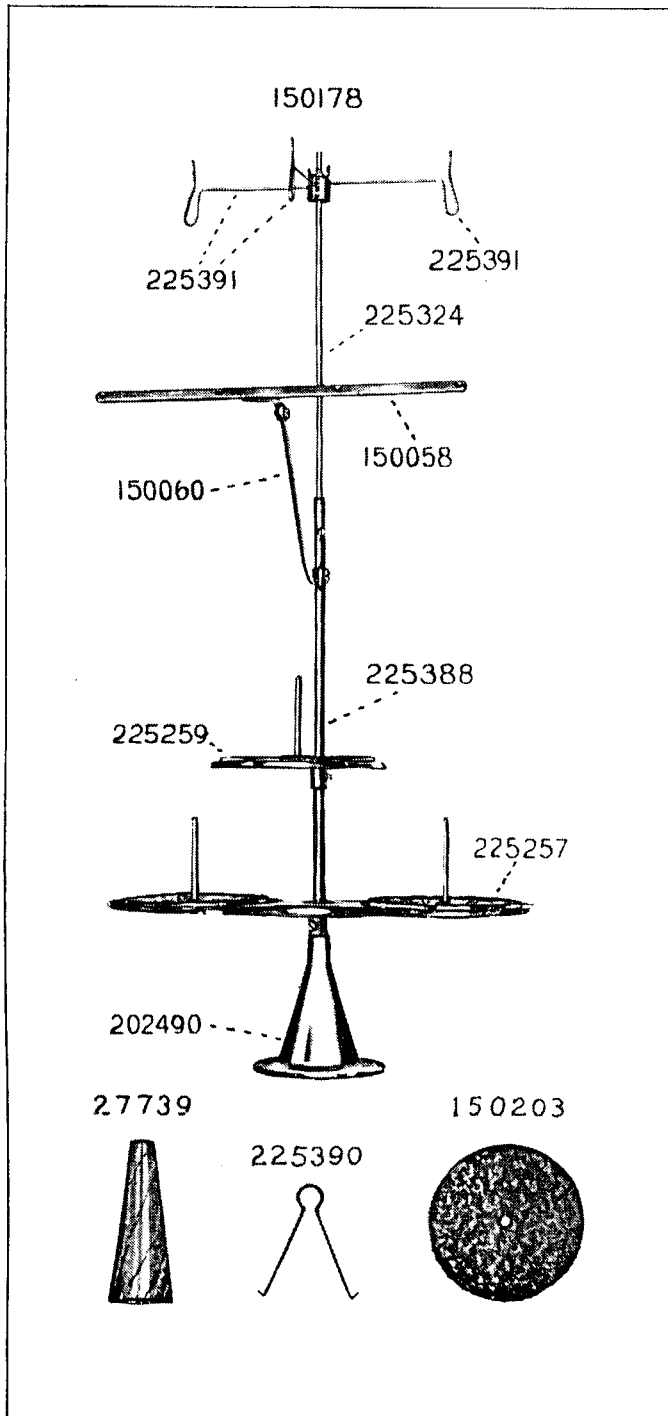

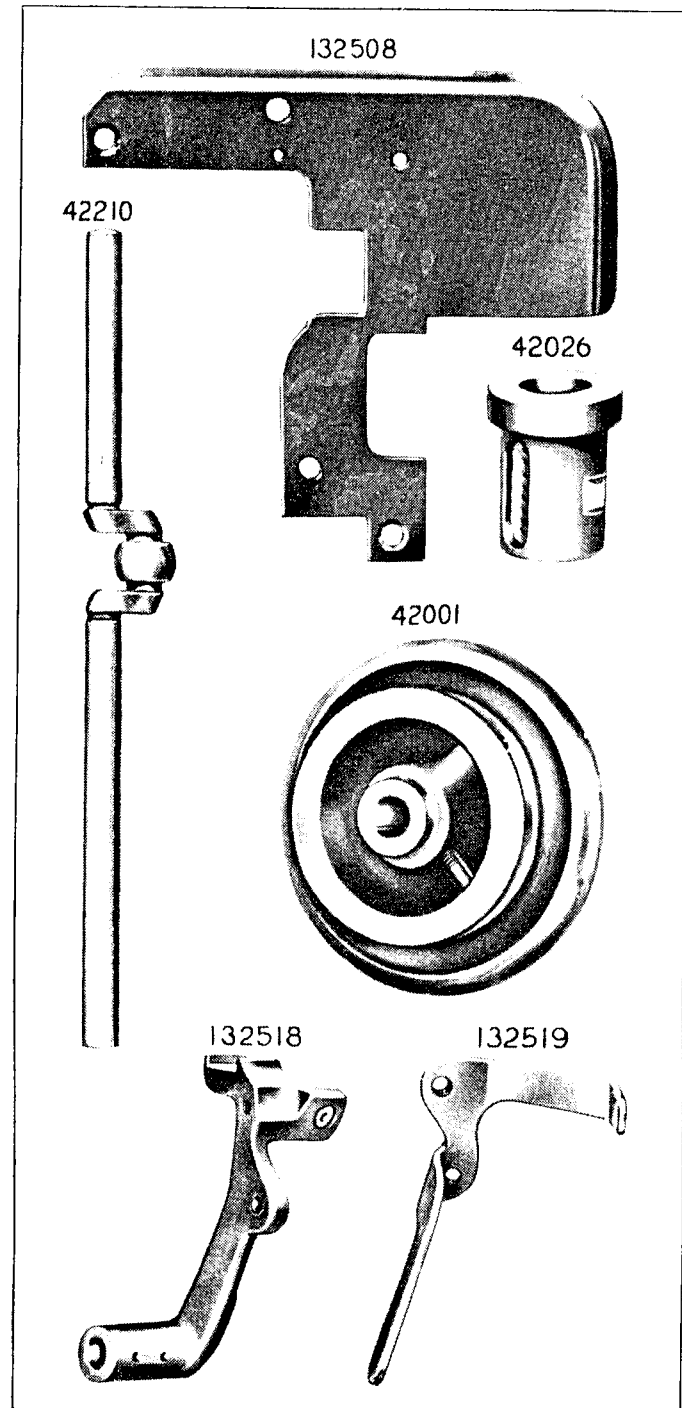
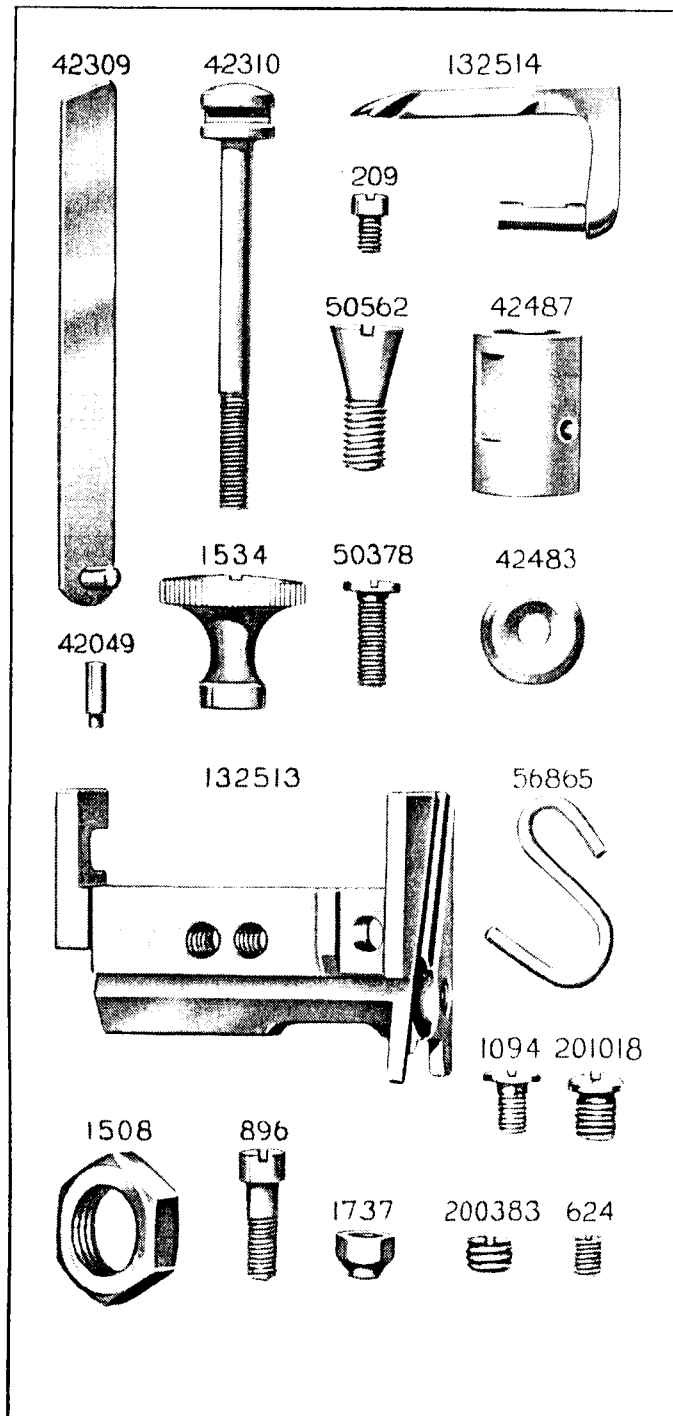

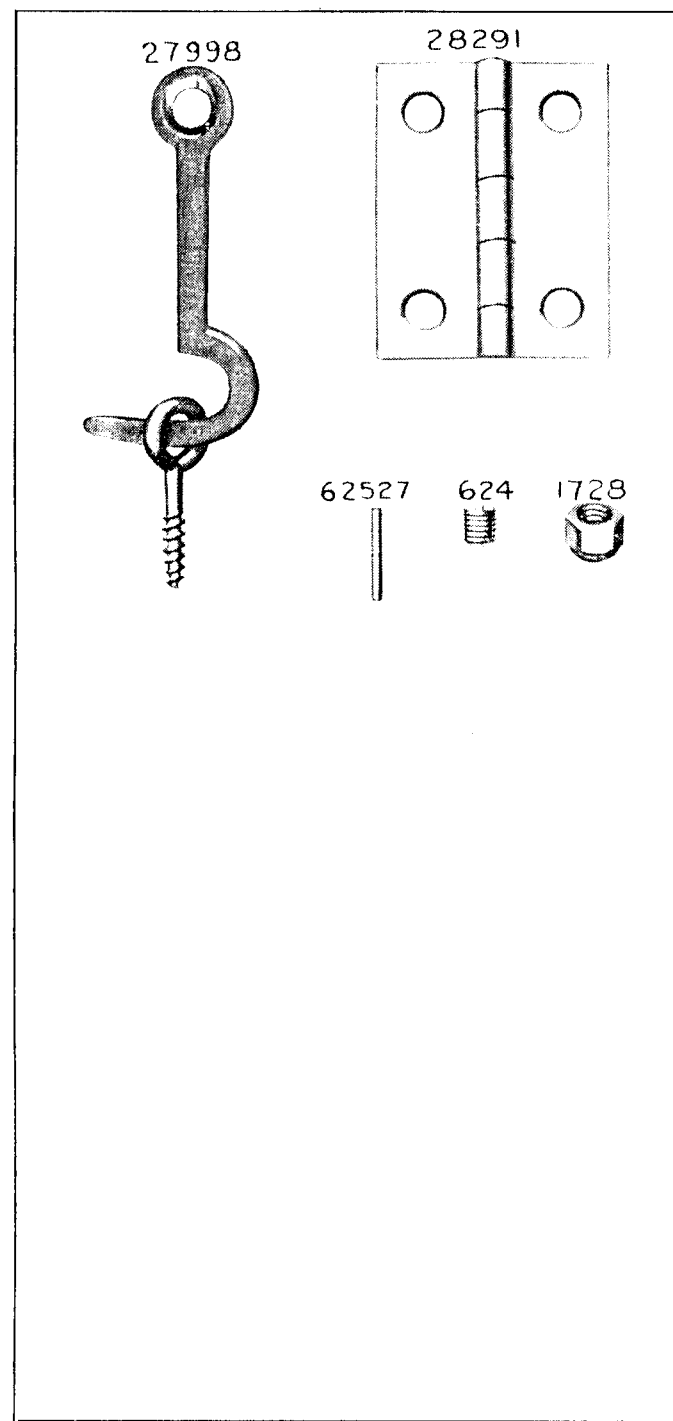
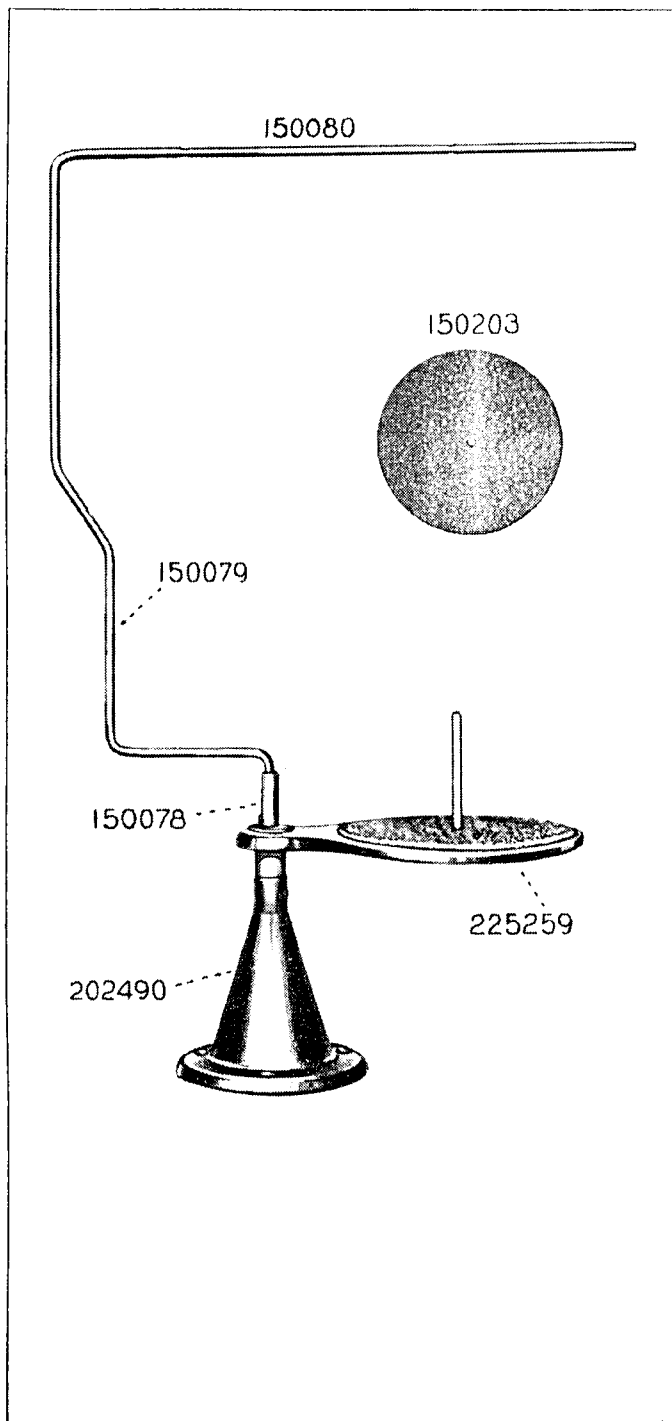

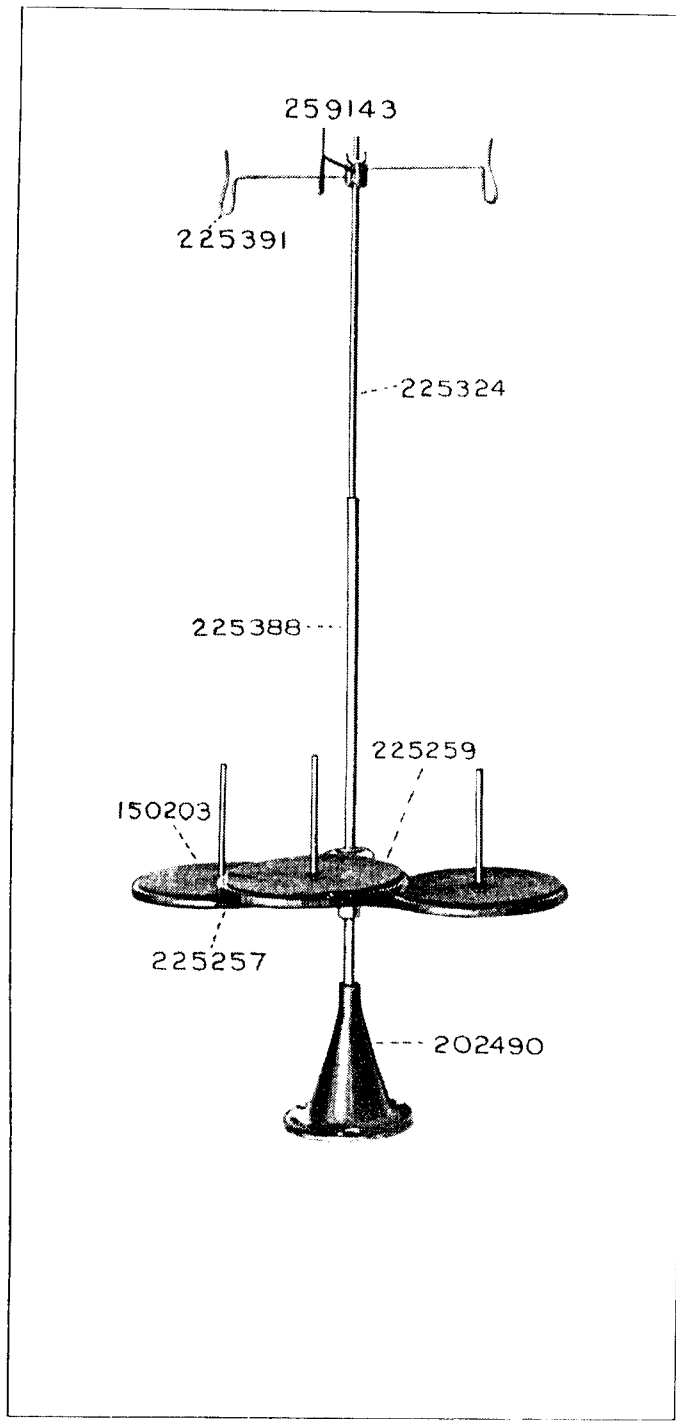

INSTRUCTIONS FOR ORDERING

In ordering from this List, the prefix and affix letters with the part number **MUST BE** quoted exactly as they are shown in the first column.

A number always indicates the same part in whatever List it may appear, or for whatever machine.

The prefix *SS* indicates Screws made only at Singer.

" " *NN* " Nuts made only at Singer.

" " *RR* " Rollers and Studs made only at Singer.

The affix letters (where shown) indicate the style of finish, as follows:—

- A. Hardened, Polished, Nickel Plated and Buffed.
- A.G. Brown Baking Enamel Finish.
- A.D. Grey Baking Enamel Finish.
- A.E. Hardened, Bright Rumbled and Nickel Plated.
- A.F. Hardened, Bright Rumbled and Nickel Plated, Bright Rumbled and Chromium Plated.
- B. Polished, Nickel Plated and Buffed.
- C. Hardened only.
- C.R. Hardened and Merlized.
- D. Polished only.
- E. Soft, not Polished.
- F. Hardened and Polished.
- F.J. Hardened, Polished and Nickel Plated.
- G. Bright Rumbled and Nickel Plated.
- H. Blued.
- J. Nickel Plated only.
- K. Hardened and Nickel Plated.
- L. Brass Plated.
- M. Oxidized.
- N. Japanned, Dull.
- P. Japanned, Bright.
- R. Merlized.
- S. Cadmium Plated.
- T. Copper Plated.
- T.A. Hardened, Polished, Copper and Nickel Plated and Buffed.
- T.B. Copper and Nickel Plated and Polished.
- T.J. Copper and Nickel Plated only.
- T.K. Hardened, Copper and Nickel Plated.
- T.L. Copper and Brass Plated.
- T.M. Copper Plated and Oxidized.
- U. Zinc Plated.
- V. Silver Plated.
- W. Polished and Nickel Plated.
- X. Black Oxide for Iron and Steel.
- X.G. Hardened and Black Oxide for Iron and Steel.
- Y. Black Nickel Plated only.
- Z. Chromium Plated.
- Z.A. Hardened, Polished, Nickel Plated, Buffed and Chromium Plated.
- Z.B. Polished, Nickel Plated, Buffed and Chromium Plated.
- Z.C. Hardened and Chromium Plated.
- Z.D. Polished and Chromium Plated.
- Z.G. Bright Rumbled, Nickel Plated, Bright Rumbled and Chromium Plated.
- Z.J. Nickel and Chromium Plated.
- Z.T. Copper and Chromium Plated.

Parts marked with an asterisk () are furnished only when the repairs are made at Factory.*

PARTS COMPLETE

FOR

No. 81K1 MACHINE

FOR TRIMMING, SCALLOPING AND OVEREDGING LACE CURTAINS AND OTHER WOVEN FABRICS, ETC., AT THE SAME TIME LAYING ONE OR MORE CORDS UNDER THE OVEREDGE STITCHES IF DESIRED. THREE-THREAD STITCH.

No.	Plate	Name	^A _L
*42484	—	Arm with 15404, two each 462a, 624c, 15405, 42253 and 42487	...
4389	5543	" Dowel Pin	...
949e	2277	" Screw	...
42001	5576	Balance Wheel, 2 $\frac{3}{16}$ " pulley, with 424c and 1354c	...
1354c	2277	" " Position Screw	...
424c	2277	" " Set Screw	...
42002	5526	Cloth Plate	...
42003	5526	" " Extension (lower)	...
229e	2277	" " " (") Screw	...
42108	5526	" " " (upper)	...
229e	2277	" " " (") Screw	...
42005	5526	" " Lock Spring	...
236c	2277	" " " " Screw	...
42107	—	Cloth Plate, complete, Nos. 42002, 42003, 42005, 42108, two 236c and five 229e	...
1437d	2277	Cloth Plate Hinge Screw	...
1655e	2277	" " " " Nut	...
42006	5529	Feed Bar with 1253c	...
*42327	—	" " 42006 with 42013	...
42007	5529	" " Hinge Pin	...
1253c	5529	" " " " Set Screw	...
42008	5529	" " Connecting Rod with 42009 and two 1057c	...
*42371	—	" " " 42008 with 1373c and 1520c	...
*42009	—	" " " Cap	...
1057c	5529	" " " " Screw	...
1373c	5529	" " " " Hinge Screw	...
1520c	5529	" " " " " Nut	...
42010	5541	" Dog (17 teeth, 16 teeth to the inch)	...
190d	5556	" " Screw	...

No.	Plate	Name				
42011	5529	Feed Eccentric with two 453c
42094	5526	" " Cover
207d	5529	" " " Screw
453c	5529	" " Set Screw
42012	5529	" Lifting Eccentric with two 462c
42013	5529	" " " Connection
462c	5529	" " " Set Screw
1374c	5530	" Regulating Screw Stud
1680c	5530	" " " " Nut
42290	5530	" " " " Washer
42014	5530	" Regulator with 233j and two 1259c
42015	5529	" " " Connection with 1012e
*42368	—	" " " 42015 with 1373c and 1520c
1012e	5529	" " " Adjusting Screw
1373c	5529	" " " Hinge Screw
1520c	5529	" " " " " Nut
42016	5530	" " " Hinge Stud
42017	5529	" " " Indicator
42018	5530	" " " " Plate
337d	5530	" " " " " Screw
207d	5529	" " " " " Screw
1259c	5530	" " " Set Screw
233j	5530	" " " Stop Screw
42019	5530	" Rock Shaft
42020	—	Feed Rock Shaft, complete, Nos. 42019 and 42021
42021	5530	Feed Rock Shaft Crank with 157e
157e	5530	" " " " Clamping Screw
42098	5530	" " " Hinge Pin
42079	5530	" " " " " Bushing
1036c	5530	" " " " " Set Screw
*42022	—	Frame
42023	5576	" Rotary Shaft
42024	5576	" " " Bushing (front)
1036c	5530	" " " " (") Set Screw
42025	2272	" " " Crank with 1259c and 1375c
1375c	2277	" " " " Position Screw
1259c	5530	" " " " Set Screw
42026	5576	" " " Flanged Bushing (back) with 54967
54967	7403	" " " " " (") Oil Pad (braided cotton)
1036c	5530	" " " " " (") Set Screw
42367	5591	" " " Front Bearing Oil Pad (braided cotton)
132560	2265	" Side Cover (left) with 132701
132701	2268	" " " (") Handle
330w	2277	" " " (") Screw

No.	Plate	Name				
42028	5526	Frame Side Cover (right, hinged)
42101	5543	" " " (") Lock Spring
330w	2277	" " " (") Screw
42029	5576	" Top Cover
42030	5543	" " " Extension
42031	5543	" " " " Cord Guide
337d	5543	" " " " " " Screw
42102	5543	" " " " Holder
283w	5543	" " " " " Thumb Screw
19044	5539	" " " " " " " Washer
176d	5543	" " " " " Screw
742f	2277	" " " " Screw
42033	5542	Knife (movable)
<i>NOTE:—Two No. 42033 are sent with this machine.</i>						
42034	5542	Knife (movable) Gib
42035	5542	" (") Holder
42036	—	" (") " 42035 with 133f, 42034, 42037, 42040 and two 404d
42037	5542	" (") " Cap
404d	5542	" (") " " Screw
42038	5542	" (") " Guide with 336f
42039	5542	" (") " " Plate
621d	5542	" (") " " " Screw
336f	5542	" (") " " Set Screw
133f	5542	" (") " " Screw
42040	5542	" (") " " Extension Pin
42041	5542	" (") " Spring
42042	5542	" (") Lever
42043	5542	" (") " Connection with 42044 and two 175e
*42369	—	" (") " " 42043 with 1373c and 1520c
*42044	—	" (") " " Cap
175e	5542	" (") " " " Screw
1373c	5542	" (") " " Hinge Screw
1520c	5542	" (") " " " " Nut
42045	5542	" (") " Hinge Stud
1229c	5542	" (") " " " Set Screw
42046	5543	Knife (stationary) with 42049
<i>NOTE:—Two 42046 are sent with this machine.</i>						
42048	5543	Knife (stationary) Clamping Stud
1534d	5543	" (") " " Thumb Nut
42047	5543	" (") Holder
1376c	5543	" (") " Regulating Thumb Screw
1101c	5543	" (") " Screw
440f	5543	" (") " Stop Screw
1547j	5543	" (") " " " Nut
42049	5543	" (") Stud

No.	Plate	Name
42050	2272	Looper (left hand)
132870	2273	" (" ") Lever with 50117c
*42318	---	" (" ") " 132870 with 42053
42052	2271	" (" ") " Connecting Link
*42384	---	" (" ") " " " 42052 with two each 1520c and 50562c
50562c	20795	" (" ") " " " Hinge Screw
1520c	5529	" (" ") " " " " Nut
42053	2272	" (" ") " Hinge Stud
1036c	5530	" (" ") " " " Set Screw
50117c	2276	" (" ") Set Screw
42166	2272	" (right hand)
42073	2271	" (" ") and Spreader Lever with 1259c
*42330	---	" (" ") " " " 42073 with 233d, 42078 and 42242
42074	2271	" (" ") " " " Ball Stud
1259c	5530	" (" ") " " " " Set Screw
42075	2271	" (" ") " " " Connection with 42059, 42076 and four 896c
42416	---	" (" ") " " " Connection 42075 with 42074
42382	---	" (" ") " " " 42416 with 42025
42380	---	" (" ") " " " 42382 with 171f and 42077
*42076	---	" (" ") " " " Cap (lower)
896c	20795	" (" ") " " " " (") Screw
*42059	---	" (" ") " " " Cap (upper)
896c	20795	" (" ") " " " " (") Screw
42077	2271	" (" ") " " " Guide
171f	5544	" (" ") " " " " Screw
42403	2273	" (" ") " " " Oil Tube and Bracket with 29599
29599	2272	" (" ") " " " Connection Oil Tube Packing (felt)
42078	2271	" (" ") " " " Hinge Pin
42079	5530	" (" ") " " " " Bushing
1259c	5530	" (" ") " " " " " Set Screw
197d	5556	" (" ") Screw
42054	5544	Needle Bar
42253	5544	" " Bushing
462c	5544	" " " Set Screw

No.	Plate	Name
42061	5514	Needle Bar Connecting Bracket with 187d and 223f
187d	5514	" " " " Clamping Screw
42055	5514	" " " " Link
*42335	---	" " " " 42055 with 42061, 42104 and two 40247
40247	5514	" " " " Hinge Pin
223f	5514	" " " " " " " Set Screw
904c	5514	" " " " " " " " " "
42057	5514	" " " " Rod with 42076, 132878 and four 896c
*42383	---	" " " " " 42057 with 42074
*42374	---	" " " " " 42383 with 42023
*42076	---	" " " " " Cap (lower)
896c	20795	" " " " " " (") Screw
*132878	---	" " " " " " (upper)
896c	20795	" " " " " " (") Screw
42077	2271	" " " " " Guide
171f	5544	" " " " " " Screw
42103	5514	" " Crank (back) with 1258c and two 1259c
42074	2271	" " " (") Ball Stud
1259c	5530	" " " (") " " Set Screw
1259c	5530	" " " (") Position Screw
1258c	5514	" " " (") Set Screw
42104	5514	" " " (front) with 904c, 1258c and 1259c
1259c	5530	" " " (") Position Screw
1258c	5544	" " " (") Set Screw
42105	5514	" " " Shaft
42487	20795	" " " " Bushing
624c	20800	" " " " " Set Screw
42115	5514	" " " Thread Retainer Bracket
228d	5514	" " " " " Screw
42483	20795	" " " " Disc
93c	5544	" " " " Screw
10107	5514	" " " " Spring
1337c	1728c	5544 20795
42066	5544	" Clamping Nut
171f	5514	" Guard
		" " Screw
42067	5511	Presser Foot with 233d and 42068
42068	5511	" " Chaining-off Finger
233d	5530	" " " " Screw
1324c	5591	" " Screw
39541	2272	" " Washer
42069	5576	" Lever
42376	---	" " 42069 with 42045
42045	5512	" " Hinge Stud
1120c	5591	" " " " Set Screw
42070	2272	" " Lifter

No.	Plate	Name			
85d	2277	Presser Lever Lifter Hinge Screw
1377c	2277	" " Screw Stud (eccentric)
1547j	5543	" " " " Nut
42071	2272	" " Spring
1378d	2277	Pressure Regulating Thumb Screw
132631	2276	Spreader
197d	5556	" Screw
2102	5556	Tension (cord) Disc
1560c	5556	" (") Regulating Thumb Nut
637c	5556	" (") Screw Stud
33929	—	" (") " " 637c with 1560c
10148	5556	" (") Spring
2102	5556	" (looper, left hand) Disc
1560c	5556	" (" " ") Regulating Thumb Nut
828c	5556	" (" " ") Screw Stud
42418	—	" (" " ") " " 828c with 1560c
42121	5556	" (" " ") Spring
2102	5556	" (looper, right hand) Disc
1560c	5556	" (" " ") Regulating Thumb Nut
828c	5556	" (" " ") Screw Stud
42418	—	" (" " ") " " 828c with 1560c
42121	5556	" (" " ") Spring
17547	5556	" (" " ") Thread Guide
2102	5556	" (needle thread) Disc
1560c	5556	" (" ") Regulating Thumb Nut
916c	5556	" (" ") Screw Stud
44209	—	" (" ") " " 916c with 1560c
10148	5556	" (" ") Spring
42082	5556	" (" ") Thread Guide
42242	7388	Thread (looper, left hand) Eyelet
233d	5530	" (" " ") " Screw
42084	5556	" (" " ") Tube
462c	5556	" (" " ") " Set Screw
42093	5556	" (looper, right hand) Staple
190d	5556	" (" " ") " Screw
42127	5556	" (" " ") Take-up
197d	5556	" (" " ") " Screw
42096	5556	" (needle) Eyelet
217j	5556	" (") " Screw
42097	5556	" (") Take-up
197d	5556	" (") " Screw
42085	5541	Throat Plate
742f	2277	" " Screw
*15404	—	Trade Mark
15405	—	" " Rivet

PARTS COMPLETE

FOR

No. 81K8 MACHINE

FOR TRIMMING, SCALLOPING AND OVEREDGING LACE CURTAINS AND OTHER WOVEN FABRICS, ETC., AT THE SAME TIME LAYING ONE OR MORE CORDS UNDER THE OVEREDGE STITCHES IF DESIRED. THE MACHINE IS FITTED WITH A DOUBLE FEED DOG. THE HEIGHT OF THE BACK FEED DOG CAN BE ADJUSTED BY A HAND LEVER AT THE BACK OF THE MACHINE TO ACCOMMODATE DIFFERENT THICKNESSES OF CORDS. ALSO FITTED WITH OIL TUBES FOR CARRYING OIL TO THE FRONT AND BACK BEARINGS. TWO-THREAD STITCH.

No.	Plate	Name			
*42486	—	Arm with 15404, two each 462c, 624c, 15405, 42253 and 42487
4389	5543	" Dowel Pin
949e	2277	" Screw
42001	5576	Balance Wheel 2 $\frac{3}{16}$ " pulley with 424c and 1354c
1354c	2277	" " Position Screw
424c	2277	" " Set Screw
42361	2263	Cloth Plate
42363	2263	" " Extension (lower)
229e	2277	" " " (") Screw
42108	5526	" " " (upper)
229e	2277	" " " (") Screw
42005	5526	" " Lock Spring
236c	2277	" " " " Screw
42362	2263	Cloth Plate, complete, Nos. 42005, 42108, 42361, 42363, two 236c and five 229e
1437d	2277	Cloth Plate Hinge Screw
1655e	2277	" " " " Nut
42031	5543	Cord Guide
42030	5543	" " Holder
176d	5543	" " " Screw
337d	5543	" " Screw

No.	Plate	Name
42341	5590	Feed (back) Adjusting Lever with 967d and 42342 ...
967d	5590	" (") " " Clamping Screw ...
42342	5590	" (") " " Stud ...
42340	5590	" (") Bar ...
61c	5590	" (") " Hinge Screw ...
42343	5541	" (") Dog (3 teeth, 16 teeth to the inch) ...
203d	5591	" (") " Screw ...
42151	5590	" (front) Bar with 1253c ...
42007	5529	" (") " Hinge Pin ...
1253c	5529	" (") " " " Set Screw ...
42344	5541	" (") Dog (17 teeth, 16 teeth to the inch) ...
190d	5556	" (") " Screw ...
42008	5529	" Connecting Rod with 42009 and two 1057c ...
*42371	—	" " " 42008 with 1373c and 1520c ...
*42009	—	" " " Cap ...
1057c	5529	" " " " Screw ...
1373c	5529	" " " Hinge Screw ...
1520c	5529	" " " " " Nut ...
42011	5529	" Eccentric with two 453c ...
42153	2265	" " Cover ...
42102	5543	" " " Holder ...
283w	5543	" " " " Thumb Screw ...
19044	5539	" " " " " Washer ...
207d	5529	" " " Screw ...
453c	5529	" " Set Screw ...
42345	5590	" Lifting Eccentric with two 462c ...
42013	5529	" " " Connection ...
462c	5529	" " " Set Screw ...
1374c	5530	" Regulating Screw Stud ...
1680c	5530	" " " " Nut ...
42290	5530	" " " " Washer ...
42014	5530	" Regulator with 233j and two 1259c ...
42015	5529	" " Connection with 1012c ...
*42368	—	" " " 42015 with 1373c and 1520c ...
1012c	5529	" " " Adjusting Screw ...
1373c	5529	" " " Hinge Screw ...
1520c	5529	" " " " " Nut ...
42016	5530	" " Hinge Stud ...
1259c	5530	" " Set Screw ...
233j	5530	" " Stop Screw ...
42019	5530	" Rock Shaft ...
42020	—	Feed Rock Shaft, complete, Nos. 42019 and 42021 ...
42021	5530	Feed Rock Shaft Crank with 157c ...
157c	5530	" " " " Clamping Screw ...
42098	5530	" " " Hinge Pin ...
42079	5530	" " " " Bushing ...
1036c	5530	" " " " " Set Screw ...

No.	Plate	Name
*42346	—	Frame ...
42023	5576	" Rotary Shaft ...
42024	5576	" " " Bushing (front) ...
1036c	5530	" " " " (") Set Screw ...
42025	2272	" " " Crank with 1259c and 1375c ...
1375c	2277	" " " " Position Screw ...
1259c	5530	" " " " Set Screw ...
42026	5576	" " " Flanged Bushing (back) with 54967 ...
54967	7403	" " " " (") Oil Pad (braided cotton) ...
1036c	5530	" " " " (") Set Screw ...
42367	5591	" " " Front Bearing Oil Pad (braided cotton) ...
132560	2265	" Side Cover (left) with 132701 ...
132701	2268	" " " (") Handle ...
330w	2277	" " " (") Screw ...
42028	5526	" " " (right, hinged) ...
42101	5543	" " " (") Lock Spring ...
330w	2277	" " " (") Screw ...
42033	5542	Knife (movable) ...
<i>NOTE. — Two No. 42033 are sent with this machine.</i>		
42034	5542	Knife (movable) Gib ...
42035	5542	" (") Holder ...
42036	—	" (") " 42035 with 133f, 42034, 42037, 42040, and two 404d ...
42037	5542	" (") " Cap ...
404d	5542	" (") " " Screw ...
42038	5542	" (") " Guide with 336f ...
42039	5542	" (") " " Plate ...
621d	5542	" (") " " " Screw ...
336f	5542	" (") " " Set Screw ...
133f	5542	" (") " " Screw ...
42040	5542	" (") " " Extension Pin ...
42041	5542	" (") " Spring ...
42042	5542	" (") Lever ...
42043	5542	" (") " Connection with 42044 and two 175c ...
*42369	—	" (") " " 42043 with 1373c and 1520c ...
*42044	—	" (") " " Cap ...
175c	5542	" (") " " " Screw ...
1373c	5542	" (") " " Hinge Screw ...
1520c	5542	" (") " " " " Nut ...
42045	5542	" (") " Hinge Stud ...
1229c	5542	" (") " " " Set Screw ...
42046	5543	" (stationary) with 42049 ...

NOTE. — Two No. 42046 are sent with this machine.

No.	Plate	Name
42048	5543	Knife (stationary) Clamping Stud ...
1534d	5543	" (") " " Thumb Nut ...
42047	5543	" (") Holder ...
1376c	5543	" (") " " Regulating Thumb Screw ...
1101c	5543	" (") " " Screw ...
440f	5543	" (") " " Stop Screw ...
1547j	5543	" (") " " Nut ...
42049	5543	" (") Stud ...
42050	2272	Looper (left hand) ...
132870	2273	" (") Lever with 50117c ...
*42318	—	" (") " " 132870 with 42053 ...
42052	2271	" (") " " Connecting Link ...
*42384	—	" (") " " " " 42052 with two each 1520c and 50562c
50562c	20795	" (") " " " " Hinge Screw ...
1520c	5529	" (") " " " " " Nut ...
42053	2272	" (") " " " Hinge Stud ...
1036c	5530	" (") " " " " Set Screw ...
50117c	2276	" (") Set Screw ...
42166	2272	" (right hand) ...
42073	2271	" (") and Spreader Lever with 1259c ...
*42330	—	" (") " " " " 42073 with 233d, 42078 and 42242
42074	2271	" (") " " " " Ball Stud ...
1259c	5530	" (") " " " " " Set Screw ...
42075	2271	" (") " " " " " Connection with 12059, 42076 and four 896c
42416	—	" (") " " " " " Connection 42075 with 42074
42382	—	" (") " " " " " " 42416 with 42025
42380	—	" (") " " " " " " 42382 with 1711 and 42077
*42076	—	" (") " " " " " " Connection Cap (lower)
896c	20795	" (") " " " " " " " (") Screw
*42059	—	" (") " " " " " " " (upper)
896c	20795	" (") " " " " " " " (") Screw
42077	2271	" (") " " " " " " " Guide ...
171f	5544	" (") " " " " " " " Screw
42403	2273	" (") " " " " " " " Oil Tube and Backet with 29599
29599	2272	" (") " " " " " " " Connection Oil Tube Packing (felt)
42078	2271	" (") " " " " " " " Hinge Pin ...

No.	Plate	Name
42079	5530	Looper (right hand) and Spreader Lever Hinge Pin Bushing ...
1259c	5530	" (") " " " " " " " " Set Screw
197d	5556	" (") Screw ...
42054	5544	Needle Bar ...
42253	5544	" " Bushing ...
462c	5544	" " " " Set Screw ...
42061	5544	" " Connecting Bracket with 187d and 223f ...
187d	5544	" " " " Clamping Screw ...
42055	5544	" " " " Link ...
*42335	—	" " " " " 42055 with 42061, 42104 and two 40247
40247	5544	" " " " " Hinge Pin ...
223f	5544	" " " " " " " " Set Screw for 42061 ...
904c	5544	" " " " " " " " " 42104 ...
42347	5590	" " " " " Rod with 42076, 132878 and four 896c
*42076	—	" " " " " " Cap (lower) ...
896c	20795	" " " " " " (") Screw ...
*132878	—	" " " " " " (upper) ...
896c	20795	" " " " " " (") Screw ...
42077	2271	" " " " " " Guide ...
171f	5544	" " " " " " " " Screw ...
42103	5544	" " Crank (back) with 1258c and two 1259c ...
42074	2271	" " " (") Ball Stud ...
1259c	5530	" " " (") " " Set Screw ...
1259c	5530	" " " (") Position Screw ...
1258c	5544	" " " (") Set Screw ...
42104	5544	" " " (front) with 904c, 1258c and 1259c ...
1259c	5530	" " " (") Position Screw ...
1258c	5544	" " " (") Set Screw ...
42105	5544	" " " " Shaft ...
42487	20795	" " " " " Bushing ...
624c	20800	" " " " " " Set Screw ...
42115	5544	" " Thread Retainer Bracket ...
228d	5544	" " " " " " Screw ...
42348	5591	" " " " " Disc (inside) ...
10106	5544	" " " " " (outside) ...
42349	5591	" " " " " (") 10106 with 42350 ...
42350	—	" " " " " (") Bushing ...
93c	5544	" " " " " Screw ...
10107	5544	" " " " " Spring ...
137c	5544	Needle Clamping Nut ...
1728c	5544	" " Guard ...
42066	5544	" " " Screw ...
171f	5544	" " " Screw ...

No. 8IK8 MACHINE PARTS

No.	Plate	Name
42351	5591	Oil Pipe with 42353 and 42354, for oiling back bearing ...
42352	5591	" " " 42353 " 42354, " " front bearing ...
42353	5591	" " Coupling ...
42354	5591	" " Oil Cup ...
42355	5591	" " Strap for 42351 ...
42356	5591	" " " for 42352 ...
207d	5529	" " " Screw for 42355 ...
742f	2277	" " " " " 42356 ...
42357	5541	Presser Foot with 220d, 233d, 42068 and 42358 ...
42068	5541	" " Chaining-off Finger ...
233d	5530	" " " " " Screw ...
1324c	5591	" " " Screw ...
39541	2272	" " " Washer ...
220d	5541	" " " Stop Screw ...
42358	5541	" " " " Stud ...
42069	5576	" " Lever ...
42376	—	" " 42069 with 42045 ...
42045	5542	" " Hinge Stud ...
1120c	5591	" " " " Set Screw ...
42070	2272	" " Lifter ...
85d	2277	" " " Hinge Screw ...
1377c	2277	" " Screw Stud (eccentric) ...
1547j	5543	" " " " Nut ...
42071	2272	" " " Spring ...
1378d	2277	Pressure Regulating Thumb Screw ...
42359	5591	Spreader ...
197d	5556	" " Screw ...
2102	5556	Tension (cord) Disc ...
1560c	5556	" (") Regulating Thumb Nut ...
637c	5556	" (") Screw Stud ...
33929	—	" (") " " 637c with 1560c ...
10148	5556	" (") Spring ...
2102	5556	" (looper, left hand) Disc ...
1560c	5556	" (" " ") Regulating Thumb Nut ...
828c	5556	" (" " ") Screw Stud ...
42418	—	" (" " ") " " 828c with 1560c ...
42121	5556	" (" " ") Spring ...
2102	5556	" (looper, right hand) Disc ...
1560c	5556	" (" " ") Regulating Thumb Nut ...
828c	5556	" (" " ") Screw Stud ...
42418	—	" (" " ") " " 828c with 1560c ...
42121	5556	" (" " ") Spring ...
17547	5556	" (" " ") Thread Guide ...

No. 8IK8 MACHINE PARTS

No.	Plate	Name
2102	5556	Tension (needle thread) Disc ...
1560c	5556	" (" ") Regulating Thumb Nut ...
916c	5556	" (" ") Screw Stud ...
44209	—	" (" ") " " 916c with 1560c ...
10148	5556	" (" ") Spring ...
42082	5556	" (" ") Thread Guide ...
42242	7388	Thread (looper, left hand) Eyelet ...
233d	5530	" (" " ") " Screw ...
42124	5590	" (" " ") Pull-off ...
42125	5590	" (" " ") " Eyelet ...
233d	5530	" (" " ") " " Screw ...
42084	5556	" (" " ") Tube ...
462c	5556	" (" " ") " Set Screw ...
42093	5556	" (looper, right hand) Staple ...
190d	5556	" (" " ") " Screw ...
42127	5556	" (" " ") Take-up ...
197d	5556	" (" " ") " Screw ...
42096	5556	" (needle) Eyelet ...
217j	5556	" (") " Screw ...
42360	5511	Throat Plate ...
742f	2277	" " Screw ...
*15404	—	Trade Mark ...
15405	—	" " Rivet ...

PARTS COMPLETE
FOR
No. 81K2 MACHINE

FOR TRIMMING AND OVEREDGING FLANNELS, MUSLINS, DENIMS
AND OTHER FABRICS; INSERTING SLEEVES IN SHIRT
WAISTS, WRAPPERS, ETC. ALSO STITCHING POCKETS INTO
TROUSERS. BIGHT ADJUSTABLE FROM $\frac{5}{32}$ " TO $\frac{7}{32}$ ". THREE-
THREAD STITCH. FOOT LIFTER.

No.	Plate	Name
*42484	—	Arm with 15404, two each 462c, 624c, 15405, 42253 and 42487 ...
4389	5543	" Dowel Pin ...
949c	2277	" Screw ...
42001	5576	Balance Wheel, 2 $\frac{3}{16}$ " pulley, with 424c and 1354c ...
1354c	2277	" " Position Screw ...
424c	2277	" " Set Screw ...
42002	5526	Cloth Plate ...
42107	—	Cloth Plate, complete, Nos. 42002, 42003, 42005, 42108, two 236c and five 229c ...
42003	5526	Cloth Plate Extension (lower) ...
229c	2277	" " " (") Screw ...
42108	5526	" " " (upper) ...
229c	2277	" " " (") Screw ...
1437d	2277	" " Hinge Screw ...
1655c	2277	" " " " Nut ...
42005	5526	" " Lock Spring ...
236c	2277	" " " " Screw ...
42006	5529	Feed Bar with 1253c ...
*42327	—	" " 42006 with 42013 ...
42007	5529	" " Hinge Pin ...
1253c	5529	" " " " Set Screw ...
42008	5529	" Connecting Rod with 42009 and two 1057c ...
*42371	—	" " " 42008 with 1373c and 1520c ...
*42009	—	" " " Cap ...
1057c	5529	" " " Screw ...
1373c	5529	" " " Hinge Screw ...
1520c	5529	" " " " Nut ...
42109	5531	" Dog (24 teeth, 16 teeth to the inch) ...
42165	5592	" " (24 teeth, 16 teeth to the inch) for 42171, for sewing very heavy pockets in trousers

No.	Plate	Name
190d	5556	Feed Dog Screw ...
42011	5529	" Eccentric with two 453c ...
42094	5526	" " Cover ...
207d	5529	" " " Screw ...
453c	5529	" " " Set Screw ...
42208	5596	" Lifting Eccentric with two 462c ...
42013	5529	" " " Connection ...
462c	5529	" " " Set Screw ...
1374c	5530	" Regulating Screw Stud ...
1680c	5530	" " " " Nut ...
42290	5530	" " " " Washer ...
42014	5530	" Regulator with 233j and two 1259c ...
42015	5529	" " Connection with 1012c ...
*42368	—	" " " 42015 with 1373c and 1520c ...
1012c	5529	" " " Adjusting Screw ...
1373c	5529	" " " Hinge Screw ...
1520c	5529	" " " " " Nut ...
42016	5530	" " " Hinge Stud ...
42017	5529	" " " Indicator ...
42018	5530	" " " Plate ...
337d	5530	" " " " Screw ...
207d	5529	" " " " Screw ...
1259c	5530	" " " Set Screw ...
233j	5530	" " " Stop Screw ...
42019	5530	" Rock Shaft ...
42020	—	Feed Rock Shaft, complete, Nos. 42019 and 42021 ...
42021	5530	Feed Rock Shaft Crank with 157c ...
157c	5530	" " " " Clamping Screw ...
42098	5530	" " " Hinge Pin ...
42079	5530	" " " " " Bushing ...
1036c	5530	" " " " " " Set Screw ...
*42022	—	Frame ...
42023	5576	" Rotary Shaft ...
42024	5576	" " " Bushing (front) ...
1036c	5530	" " " " (") Set Screw ...
42110	2272	" " " Crank with 1036c and 1375c ...
1375c	2277	" " " " Position Screw ...
1036c	5530	" " " " Set Screw ...
42026	5576	" " " Flanged Bushing (back) with 54967 ...
54967	7403	" " " " " (") Oil Pad (braided cotton)
1036c	5530	" " " " " (") Set Screw ...
42367	5591	" " " Front Bearing Oil Pad (braided cotton) ...
132560	2265	" Side Cover (left) with 132701 ...
132701	2268	" " " (") Handle ...

No. 81K2 MACHINE PARTS

No.	Plate	Name				
330w	2277	Frame Side Cover (left)	Screw
42028	5526	" " "	(right, hinged)
42101	5543	" " "	(right) Lock Spring
330w	2277	" " "	(") Screw
42029	5576	" Top Cover
132650	2268	" " "	Extension
42102	5543	" " "	" Holder
283w	5543	" " "	" " Thumb Screw
19011	5539	" " "	" " " Washer
176d	5543	" " "	" Screw
742f	2277	" " "	Screw
42111	5542	Knife (movable) for light work
42213	5560	" (") " heavy work

NOTE.—Two No. 42213 are sent with this machine.

42112	5542	Knife (movable) Gib for 42113
42214	5560	" (") " " 42215
42035	5542	" (") Holder
42113	—	" (") " 42035 with 133f, 42037, 42040, 42112
		and two 404d, for 42111
42215	—	" (") " 42035 with 133f, 42040, 42214, 42216
		and two 404d, for 42213
42037	5542	" (") " Cap for 42113
42216	5560	" (") " " 42215
404d	5542	" (") " " Screw
42038	5542	" (") " Guide with 336f
42039	5542	" (") " Guide Plate
621d	5542	" (") " " " Screw
336f	5542	" (") " " Set Screw
133f	5542	" (") " Screw
42040	5542	" (") " " Extension Pin
42041	5542	" (") " Spring
42042	5542	" (") Lever
42217	5560	" (") " Connection with 42218 and two 175e
*42370	—	" (") " " 42217 with 1373c and 1520c
*42218	—	" (") " " Cap
175e	5542	" (") " " " Screw
1373c	5529	" (") " " Hinge Screw
1520c	5529	" (") " " " Nut
42045	5542	" (") " Hinge Stud
1229c	5542	" (") " " " Set Screw

42046 5543 Knife (stationary) with 42049

NOTE.—Two No. 42046 are sent with this machine.

No. 81K2 MACHINE PARTS

No.	Plate	Name				
42048	5543	Knife (stationary) Clamping Stud
1534d	5543	" (") " " Thumb Nut
132766	2267	" (") Holder...
1376e	5543	" (") " Regulating Thumb Screw
1101e	5543	" (") " Screw
440f	5543	" (") " Stop Screw
1547j	5543	" (") " " " Nut
42049	5543	" (") Stud
42114	2272	Looper (left hand)
132870	2273	" (" ") Lever with 50117c
*42318	—	" (" ") " 132870 with 42053
42052	2271	" (" ") " Connecting Link
*42384	—	" (" ") " " 42052 with two each
		1520c and 50562c
50562c	20795	" (" ") " " Hinge Screw
1520c	5529	" (" ") " " " Nut
42053	2272	" (" ") " Hinge Stud
1036c	5530	" (" ") " " Set Screw
50117c	2276	" (" ") Set Screw
42166	2272	" (right hand)
42073	2271	" (" ") and Spreader Lever with 1259c
*42330	—	" (" ") " " 42073 with 233d, 42078
		and 42242
42074	2271	" (" ") " " Ball Stud
1259c	5530	" (" ") " " " Set Screw
42075	2271	" (" ") " " Connection with 42059,
		42076 and four 896c
42416	—	" (" ") " " Connection 42075 with
		42074
42379	—	" (" ") " " " 42416 with
		42110
*42076	—	" (" ") " " " Cap (lower)
896c	20795	" (" ") " " " " (")
		Screw
*42059	—	" (" ") " " " Cap (upper)
896c	20795	" (" ") " " " " (")
		Screw
42077	2271	" (" ") " " " Guide
171f	5544	" (" ") " " " Screw
42403	2273	" (" ") " " " Oil Tube
		and Bracket with 29599
29599	2272	" (" ") " " " Connection Oil Tube
		Packing (felt)
42078	2271	" (" ") " " " Hinge Pin
42079	5530	" (" ") " " " Bushing

No.	Plate	Name
1259c	5530	Looper (right hand) and Spreader Lever Hinge Pin Bushing Set Screw
197d	5556	" (" ") Screw
42054	5544	Needle Bar
42253	5544	" " Bushing
462c	5529	" " " Set Screw
42061	5544	" " Connecting Bracket with 187d and 223f
187d	5544	" " " " Clamping Screw
42055	5544	" " " Link
*42335	---	" " " " 42055 with 42061, 42104 and two 40247
40247	5544	" " " " Hinge Pin
223f	5544	" " " " " " " Set Screw for 42061
904c	5544	" " " " " " " " " 42104
42057	5544	" " " " Rod with 42076, 132878 and four 896c
*42383	---	" " " " " 42057 with 42074
*42374	---	" " " " " 42383 with 42023
*42076	---	" " " " " Cap (lower)
896c	20795	" " " " " " (") Screw
*132878	---	" " " " " " (upper)
896c	20795	" " " " " " (") Screw
42077	2271	" " " " " Guide
171f	5544	" " " " " " Screw
42103	5544	" " " " Crank (back) with 1258c and two 1259c
42074	2271	" " " " (") Ball Stud
1259c	5530	" " " " (") " " Set Screw
1259c	5530	" " " " (") Position Screw
1258c	5544	" " " " (") Set Screw
42104	5544	" " " " (front) with 904c, 1258c and 1259c
1259c	5530	" " " " (") Position Screw
1258c	5544	" " " " (") Set Screw
42105	5544	" " " " Shaft
42487	20795	" " " " " Bushing
624c	20800	" " " " " " Set Screw
42115	5544	" " " " Thread Retainer Bracket
228d	5544	" " " " " " Screw
42483	20795	" " " " " Disc
93c	5544	" " " " " Screw
10107	5544	" " " " " Spring
(737) 1728c	20800 20) 86	Clamping Nut
42066	5544	" Guard
171f	5544	" " Screw
42138	---	Presser Foot Body
42172	5592	" " Chaining-off Finger, for $\frac{1}{16}$ " bight
42117	5592	" " " " " " $\frac{1}{8}$ " "

No.	Plate	Name
42118	5592	Presser Foot Chaining-off Finger, for $\frac{3}{16}$ " bight
42119	5592	" " " " " $\frac{1}{4}$ " "
233d	5530	" " " " " Screw
42120	5592	" " Extension
197f	5556	" " " Screw
42116	5592	Presser Foot, complete, for sewing in sleeves, Nos. 197f, 233d, 42118, 42120 and 42138
42168	5592	Presser Foot Chaining-off Finger
233d	5530	" " " " " Screw
42120	5592	" " Extension
197f	5556	" " " " " Screw
62527	20800	" " Hinge Pin
42167	---	" " Plate
42169	---	" " Shank
42170	5592	Presser Foot (hinged), complete, Nos. 197f, 233d, 42120, 42167 to 42169 and 62527
1324c	5591	Presser Foot Screw
39541	2272	" " " Washer
42069	5576	" Lever
42376	---	" " 42069 with 42045
42045	5542	" " Hinge Stud
1120c	5591	" " " " Set Screw
42070	2272	" " Lifter
85d	2277	" " " Hinge Screw
1377c	2277	" " Screw Stud (eccentric)
1547j	5543	" " " " Nut
42071	2272	" " Spring
1378d	2277	Pressure Regulating Thumb Screw
132631	2276	Spreader
197d	5556	" " Screw
2102	5556	(2) Tension (looper, left hand) Disc
1560c	5556	" (" " ") Regulating Thumb Nut
828c	5556	" (" " ") Screw Stud
42418	---	" (" " ") " " 828c with 1560c
42121	5556	" (" " ") Spring
2102	5556	(2) " (looper, right hand) Disc
1560c	5556	" (" " ") Regulating Thumb Nut
828c	5556	" (" " ") Screw Stud
42418	---	" (" " ") " " 828c with 1560c
10148	5556	" (" " ") Spring
17547	5556	" (" " ") Thread Guide

No.	Plate	Name
2102	5556	Tension (needle thread) Disc <i>See list (2)</i> ...
1560c	5556	" (" ") Regulating Thumb Nut ...
916c	5556	" (" ") Screw Stud ...
44209	-	" (" ") " " 916c with 1560c ...
8238	5556	" (" ") Spring ...
2103	5556	" (" ") " used in sewing very heavy pockets in trousers
42082	5556	" (" ") Thread Guide ...
42242	7388	Thread (looper, left hand) Eyelet ...
233d	5530	" (" " ") " Screw ...
42122	7388	" (" " ") Nipper Spring (lower) ...
42123	7388	" (" " ") " " (upper) ...
176d	5543	" (" " ") " " Screw ...
42124	5590	" (" " ") Pull-off ...
42125	5590	" (" " ") " Eyelet ...
233d	5530	" (" " ") " " Screw ...
42084	5556	" (" " ") Tube ...
462c	5529	" (" " ") " Set Screw ...
42126	2266	" (looper, right hand) Pull-off ...
42093	5556	" (" " ") Staple ...
190d	5556	" (" " ") " Screw ...
42127	5556	" (" " ") Take-up ...
197d	5556	" (" " ") " Screw ...
42096	5556	" (needle) Eyelet ...
217j	5556	" (") " Screw ...
42128	2274	" (") Take-up ...
197d	5556	" (") " Screw ...
42129	5531	Throat Plate, for $\frac{1}{8}$ ", $\frac{3}{16}$ " and $\frac{1}{4}$ " bight, for 42109 ...
42134	5531	" " " $\frac{1}{16}$ " bight, for 42109 ...
42171	5592	" " " 42165 ...
742f	2277	" " Screw ...
*15404	-	Trade Mark ...
15405	-	" " Rivet ...

PARTS COMPLETE

FOR

No. 81K5 MACHINE

FOR TRIMMING AND OVEREDGING FABRICS UP TO $\frac{5}{16}$ " THICK;
ALSO FOR CLOSING POCKETS AND STITCHING OVER HEAVY
SEAMS IN TROUSERS. BIGHT ADJUSTABLE FROM $\frac{5}{32}$ " TO $\frac{3}{16}$ ".
THREE-THREAD STITCH. FOOT LIFTER.

No.	Plate	Name
*42185	-	Arm with 15404, two each 462c, 624c, 15405, 42253 and 42487 ...
4389	5543	" Dowel Pin ...
949e	2277	" Screw ...
42001	5576	Balance Wheel, 2 $\frac{3}{16}$ " pulley, with 424c and 1354c ...
1354c	2277	" " Position Screw ...
424c	2277	" " Set Screw ...
42002	5526	Cloth Plate ...
42107	-	Cloth Plate, complete, Nos. 42002, 42003, 42005, 42108, two 236c and five 229c ...
42003	5526	Cloth Plate Extension (lower) ...
229e	2277	" " " (") Screw ...
42108	5526	" " " (upper) ...
229e	2277	" " " (") Screw ...
1437d	2277	" " Hinge Screw ...
1655e	2277	" " " " Nut ...
42005	5526	" " Lock Spring ...
236e	2277	" " " " Screw ...
42006	5529	Feed Bar with 1253c ...
*42327	-	" " 42006 with 42013 ...
42007	5529	" " Hinge Pin ...
1253c	5529	" " " " Set Screw ...
42008	5529	" Connecting Rod with 42009 and two 1057c ...
*42371	-	" " " 42008 with 1373c and 1520c ...
*42009	-	" " " Cap ...
1057c	5529	" " " " Screw ...
1373c	5529	" " " " Hinge Screw ...
1520c	5529	" " " " " Nut ...
42207	5594	" Dog (26 teeth, 16 teeth to the inch) ...
190d	5556	" " Screw ...

No. 81K5 MACHINE PARTS

No.	Plate	Name
42011	5529	Feed Eccentric with two 453c
42094	5526	" " Cover
207d	5529	" " " Screw
453c	5529	" " Set Screw
42208	5596	" Lifting Eccentric with two 462c
42013	5529	" " " Connection
462c	5529	" " " Set Screw
1374c	5530	" Regulating Screw Stud
1680c	5530	" " " Nut
42290	5530	" " " Washer
42014	5530	" Regulator with 233j and two 1259c
42015	5529	" " Connection with 1012e
*42368	—	" " " 42015 with 1373c and 1520c
1012e	5529	" " Adjusting Screw
1373c	5529	" " Hinge Screw
1520c	5529	" " " Nut
42016	5530	" " Hinge Stud
42017	5529	" " Indicator
42018	5530	" " " Plate
337d	5530	" " " Screw
207d	5529	" " " Screw
1259c	5530	" " Set Screw
233j	5530	" " Stop Screw
42019	5530	" Rock Shaft
42020	—	Feed Rock Shaft, complete, Nos. 42019 and 42021
42021	5530	Feed Rock Shaft Crank with 157e
157e	5530	" " " Clamping Screw
42098	5530	" " " Hinge Pin
42079	5530	" " " Bushing
1036c	5530	" " " " Set Screw
*42209	—	Frame
42266	2263	" Rotary Shaft
42024	5576	" " " Bushing (front)
1036c	5530	" " " (") Set Screw
42211	5596	" " " Crank with 1036c and 1375e
1375e	2277	" " " Position Screw
1036c	5530	" " " Set Screw
42026	5576	" " " Flanged Bushing (back) with 54967
54967	7403	" " " " (") Oil Pad (braided cotton)
1036c	5530	" " " " (") Set Screw
42367	5591	" " " Front Bearing Oil Pad (braided cotton)
132560	2265	" Side Cover (left) with 132701
132701	2268	" " " (") Handle
330w	2277	" " " (") Screw

No. 81K5 MACHINE PARTS

No.	Plate	Name
42028	5526	Frame Side Cover (right, hinged)
42101	5543	" " " (") Lock Spring
330w	2277	" " " (") Screw
42029	5576	" Top Cover
42212	5596	" " " Extension
42102	5543	" " " " Holder
*42329	—	" " " " 42102 with 42094 and two 207d
*42334	—	" " " " 42329 with 42101, 42212 and two 176d
283w	5543	" " " " Thumb Screw
19044	5539	" " " " Washer
176d	5543	" " " Screw
742f	2277	" " " Screw
42213	5560	Knife (movable)
<i>NOTE:—Two No. 42213 are sent with this machine.</i>		
42214	5560	Knife (movable) Gib
42035	5542	" (") Holder
42215	—	" (") " 42035 with 133f, 42040, 42214, 42216 and two 404d
42216	5560	" (") " Cap
404d	5542	" (") " Screw
42038	5542	" (") " Guide with 336f
42039	5542	" (") " " Plate
621d	5542	" (") " " Screw
336f	5542	" (") " " Set Screw
133f	5542	" (") " Screw
42040	5542	" (") " " Extension Pin
12041	5542	" (") " Spring
42012	5542	" (") Lever
42217	5560	" (") " Connection with 42218 and two 175e
*42370	—	" (") " " 42217 with 1373c and 1520c
*42218	—	" (") " " Cap
175e	5542	" (") " " Screw
1373c	5529	" (") " " Hinge Screw
1520c	5529	" (") " " " Nut
42045	5542	" (") " Hinge Stud
1229c	5542	" (") " " Set Screw
42046	5543	" (stationary) with 42049
<i>NOTE:—Two No. 42046 are sent with this machine.</i>		
42048	5543	Knife (stationary) Clamping Stud
1534d	5543	" (") " Thumb Nut
132766	2267	" (") Holder
1376c	5543	" (") " Regulating Thumb Screw

No.	Plate	Name
1101c	5543	Knife (stationary) Holder Screw
440f	5543	" (") " Stop Screw
1547j	5543	" (") " " " Nut
42049	5543	" (") Stud
42219	5560	Looper (left hand)
132870	2273	" (" ") Lever with 50117c
*42318	—	" (" ") " 132870 with 42053
42052	2271	" (" ") " Connecting Link
*42384	—	" (" ") " " " 42052 with two each 1520c and 50562c
50562c	20795	" (" ") " " " Hinge Screw
1520c	5529	" (" ") " " " " " Nut
42053	2272	" (" ") " Hinge Stud
1036c	5530	" (" ") " " " Set Screw
50117c	2276	" (" ") Set Screw
42220	5560	" (right hand)
42073	2271	" (" ") and Spreader Lever with 4259c
*42330	—	" (" ") " " " 42073 with 233d, 42078 and 42242
42221	5560	" (" ") " " " Ball Stud
1259c	5530	" (" ") " " " " " Set Screw
42075	2271	" (" ") " " " Connection with 42059, 42076 and four 896c
*42076	—	" (" ") " " " Connection Cap (lower)
896c	20795	" (" ") " " " " " (") Screw
*42059	—	" (" ") " " " " " Cap (upper)
896c	20795	" (" ") " " " " " (") Screw
42077	2271	" (" ") " " " " Guide
171f	5544	" (" ") " " " " " " Screw
42403	2273	" (" ") " " " " Oil Tube and Bracket with 29599
29599	2272	" (" ") " " " " Connection Oil Tube Packing (felt)
42078	2271	" (" ") " " " " Hinge Pin
42079	5530	" (" ") " " " " " Bushing
1259c	5530	" (" ") " " " " " " Set Screw
197d	5556	" (" ") Screw
38534	5560	Needle Bar (hollow)
42253	5544	" " Bushing
462c	5529	" " " Set Screw
42291	5596	" " Connecting Bracket with 223f and 1057c

No.	Plate	Name
1057c	5529	Needle Bar Connecting Bracket Clamping Screw
42055	5544	" " " Link
*42326	—	" " " " 42055 with 42104, 42291 and two 40247
40247	5544	" " " " Hinge Pin
223f	5544	" " " " " " " Set Screw for 42291
904c	5544	" " " " " " " 42104
42057	5544	" " " " Rod with 42076, 132878 and four 896c
*42383	—	" " " " " 42057 with 42074
*42373	—	" " " " " 12383 with 42266
*42076	—	" " " " " Cap (lower)
896c	20795	" " " " " " (") Screw
*132878	—	" " " " " " (upper)
896c	20795	" " " " " " (upper) Screw
42077	2271	" " " " " Guide
171f	5544	" " " " " " Screw
42103	5544	" " Crank (back) with 1258c and two 1259c
42074	2271	" " " (") Ball Stud
1259c	5530	" " " (") " " Set Screw
1259c	5530	" " " (") Position Screw
1258c	5544	" " " (") Set Screw
42104	5544	" " " (front) with 904c, 1258c and 1259c
1259c	5530	" " " (") Position Screw
1258c	5544	" " " (") Set Screw
42105	5544	" " " Shaft
42187	20795	" " " " Bushing
624c	20800	" " " " " Set Screw
42115	5544	" " " Thread Retainer Bracket
228d	5544	" " " " " Screw
42483	20795	" " " " Disc
93c	5544	" " " " Screw
10197	5544	" " " " Spring
1728c	20800	" Clamping Nut
42066	5544	" Guard
171f	5544	" " Screw
42223	—	Presser Foot Body
42168	5592	" " Chaining-off Finger
233d	5530	" " " " Screw
42224	5591	" " Extension
197f	5556	" " " Screw
62527	20800	" " Hinge Pin
42225	—	" " Plate
42226	5591	Presser Foot (hinged), complete, Nos. 197f, 233d, 42168, 42223 to 42225 and 62527

No.	Plate	Name						
1324c	5591	Presser Foot Screw
39541	2272	" " " Washer
42227	2271	" Lever
42377	—	" " 42227 with 42045
42045	5542	" " Hinge Stud
1120c	5591	" " " " Set Screw
42070	2272	" " Lifter
85d	2277	" " Hinge Screw
1377c	2277	" " Screw Stud (eccentric)
1517j	5513	" " " " Nut
42071	2272	" " Spring
1378d	2277	Pressure Regulating Thumb Screw
42250	5560	Spreader
197d	5556	" Screw
2102	5556	Tension (looper, left hand) Disc
1560c	5556	" (" " ") Regulating Thumb Nut
828c	5556	" (" " ") Screw Stud
42418	—	" (" " ") " " 828c with 1560c
42121	5556	" (" " ") Spring
2102	5556	" (looper, right hand) Disc
1560c	5556	" (" " ") Regulating Thumb Nut
828c	5556	" (" " ") Screw Stud
42418	—	" (" " ") " " 828c with 1560c
10148	5556	" (" " ") Spring
17547	5556	" (" " ") Thread Guide
2102	5556	" (needle thread) Disc
1560c	5556	" (" " ") Regulating Thumb Nut
916c	5556	" (" " ") Screw Stud
44209	—	" (" " ") " " 916c with 1560c
2103	5556	" (" " ") Spring
42082	5556	" (" " ") Thread Guide
42242	7388	Thread (looper, left hand) Eyelet
233d	5530	" (" " " ") " Screw
42122	7388	" (" " " ") Nipper Spring (lower)
42123	7388	" (" " " ") " " (upper)
176d	5543	" (" " " ") " " Screw
42124	5590	" (" " " ") Pull off
42125	5590	" (" " " ") " Eyelet
233d	5530	" (" " " ") " " Screw
42084	5556	" (" " " ") Tube
462c	5529	" (" " " ") " Set Screw
42126	2266	" (looper, right hand) Pull off
42093	5556	" (" " " ") Staple
190d	5556	" (" " " ") " Screw

No.	Plate	Name						
42127	5556	Thread (looper, right hand) Take-up
197d	5556	" (" " " ") " Screw
42096	5556	" (needle) Eyelet
217j	5556	" (") " Screw
42128	2274	" (") Take-up
197d	5556	" (") " Screw
42228	5594	Throat Plate
742f	2277	" " Screw
*15404	—	Trade Mark
15405	—	" " Rivet

PARTS COMPLETE
FOR
No. 81K13 MACHINE

FOR SERGING PANTS AND CUT EDGES OF CLOTH. NO TRIMMER.
HAS GUIDE, ADJUSTABLE FOR DIFFERENT THICKNESSES
AND WIDTH OF BIGHT. TWO-THREAD STITCH. FOOT
LIFTER.

No.	Plate	Name
*42484	--	Arm with 15404, two each 462c, 624c, 15405, 42253 and 42487
4389	5543	" Dowel Pin
949e	2277	" Screw
42001	5576	Balance Wheel, 2 $\frac{3}{8}$ " pulley, with 424c and 1354c
1354c	2277	" " Position Screw
424c	2277	" " Set Screw
42002	5526	Cloth Plate
42107	--	Cloth Plate, complete, Nos. 42002, 42003, 42005, 42108, two 236c and five 229e
42003	5526	Cloth Plate Extension (lower)
229e	2277	" " " (") Screw
42108	5526	" " " (upper)
229e	2277	" " " (") Screw
1437d	2277	" " Hinge Screw
1655e	2277	" " " " Nut
42005	5526	" " Lock Spring
236c	2277	" " " " Screw
42205	5596	Feed Bar with 1253c
*42333	--	" " 42205 with 42013
42007	5529	" " Hinge Pin
1253c	5529	" " " " Set Screw
42008	5529	" Connecting Rod with 42009 and two 1057c
*42371	--	" " " 42008 with 1373c and 1520c
*42009	--	" " " Cap
1057c	5529	" " " Cap Screw
1373c	5529	" " " Hinge Screw
1520c	5529	" " " " Nut
42267	5595	" Dog (23 teeth, 16 teeth to the inch)

No.	Plate	Name
190d	5556	Feed Dog Screw
42011	5529	" Eccentric with two 453c
42094	5526	" " Cover
42102	5543	" " " Holder
283w	5543	" " " " Thumb Screw
19044	5539	" " " " " Washer
207d	5529	" " " " Screw
453c	5529	" " Set Screw
42012	5529	" Lifting Eccentric with two 462c
42013	5529	" " " Connection
462c	5529	" " " Set Screw
4374c	5530	" Regulating Screw Stud
1680c	5530	" " " " Nut
42290	5530	" " " " Washer
12044	5530	" Regulator with 233j and two 1259c
12045	5529	" " " Connection with 1012e
*42368	--	" " " 42015 with 1373c and 1520c
1012e	5529	" " " Adjusting Screw
1373c	5529	" " " Hinge Screw
1520c	5529	" " " " " Nut
12046	5530	" " Hinge Stud
1259c	5530	" " Set Screw
37554	5596	" " Stop
233j	5530	" " " Screw
42019	5530	" Rock Shaft
42020	--	Feed Rock Shaft, complete, Nos. 42019 and 42021
42021	5530	Feed Rock Shaft Crank with 157c
157c	5530	" " " " Clamping Screw
42098	5530	" " " Hinge Pin
42079	5530	" " " " Bushing
1036c	5530	" " " " " Set Screw
*42022	--	Frame
42023	5576	" Rotary Shaft
42024	5576	" " " Bushing (front)
1036c	5530	" " " " (") Set Screw
42025	2272	" " " Crank with 1259c and 1375c
1375c	2277	" " " " Position Screw
1259c	5530	" " " " Set Screw
42026	5576	" " " Flanged Bushing (back) with 54967
54967	7103	" " " " " (") Oil Pad (braided cotton)
1036c	5530	" " " " " (") Set Screw
42367	5591	" " " Front Bearing Oil Pad (braided cotton)
132638	2265	" Side Cover (left) with 132701
132701	2268	" " " (") Handle

No.	Plate	Name
330w	2277	Frame Side Cover (left) Screw
42028	5526	" " " (right, hinged)
42192	5560	" " " (") Lock Spring
330w	2277	" " " (") " Screw
330w	2277	" " " (") Screw
42029	5576	" Top Cover
742f	2277	" " " Screw
38571	5595	Guide with 230h and 38572
217d	5556	" Screw
7071	5595	" " Washer
38572	5595	" Smoothing Plate
230h	5595	" " " Screw
42114	2272	Looper (left hand)
132870	2273	" (" ") Lever with 50117c
*42318	—	" (" ") " 132870 with 42053
42052	2271	" (" ") " Connecting Link
*42384	—	" (" ") " " 42052 with two each 1520c and 50562c
50562c	20795	" (" ") " " " Hinge Screw
1520c	5529	" (" ") " " " " " Nut
42053	2272	" (" ") " Hinge Stud
1036c	5530	" (" ") " " " Set Screw
50117c	2276	" (" ") Set Screw
42166	2272	" (right hand)
42073	2271	" (" ") and Spreader Lever with 1259c
*42330	—	" (" ") " " 42073 with 233d, 42078 and 42242
42074	2271	" (" ") " " " Ball Stud
1259c	5530	" (" ") " " " " Set Screw
42075	2271	" (" ") " " " Connection with 42059, 42076 and four 896c
42416	—	" (" ") " " " Connection 42075 with 42074
42382	—	" (" ") " " " 42416 with 42025
42380	—	" (" ") " " " 42382 with 171f and 42077
*42076	—	" (" ") " " " Connection Cap (lower)
896c	20795	" (" ") " " " " (") Screw
*42059	—	" (" ") " " " Cap (upper)
896c	20795	" (" ") " " " " (") Screw
42077	2271	" (" ") " " " Guide
171f	5544	" (" ") " " " " Screw

No.	Plate	Name
42403	2273	Looper (right hand) and Spreader Lever Connection Oil Tube and Bracket with 29599
29599	2272	" (" ") " " " " Connection Oil Tube Packing (6cl)
42078	2271	" (" ") " " " " Hinge Pin
42079	5530	" (" ") " " " " " Bushing
1259c	5530	" (" ") " " " " " " Set Screw
197d	5556	" (" ") Screw
42054	5544	Needle Bar
42253	5544	" " Bushing
462c	5529	" " " Set Screw
42061	5544	" " Connecting Bracket with 187d and 223f
187d	5544	" " " " Clamping Screw
42055	5544	" " " " Link
*42335	—	" " " " 42055 with 42061, 42104 and two 40247
40247	5544	" " " " Hinge Pin
223f	5544	" " " " " " " Set Screw for 42061
901c	5544	" " " " " " " " 42104
42057	5544	" " " " Rod with 42076, 132878 and four 896c
*42383	—	" " " " " 42057 with 42074
*42371	—	" " " " " 42383 with 42023
*42076	—	" " " " " Cap (lower)
896c	20795	" " " " " " (") Screw
*132878	—	" " " " " " (upper)
896c	20795	" " " " " " (") Screw
42077	2271	" " " " " Guide
171f	5544	" " " " " " Screw
42103	5544	" " Crank (back) with 1258c and two 1259c
42074	2271	" " " (") Ball Stud
1259c	5530	" " " (") " " Set Screw
1259c	5530	" " " (") Position Screw
1258c	5544	" " " (") Set Screw
42104	5544	" " " (front) with 901c, 1258c and 1259c
1259c	5530	" " " (") Position Screw
1258c	5544	" " " (") Set Screw
42105	5544	" " " Shaft
42487	20795	" " " " Bushing
624c	20800	" " " " " Set Screw
42115	5544	" " Thread Retainer Bracket
228d	5544	" " " " " Screw
42483	20795	" " " " Disc
93c	5544	" " " " Screw
10107	5544	" " " " Spring
1728c	20800	" Clamping Nut

No.	Plate	Name					
42066	5544	Needle Guard
42195	5596	" " Holder
1101c	5543	" " " Screw
171f	5544	" " Screw
42268	5549	Presser Foot Chaining-off Finger
233d	5530	" " " " Screw
42269	5519	" " Extension
197f	5556	" " " Screw
62527	20800	" " Hinge Pin
42270	---	" " Plate
42169	---	" " Shank
42271	5549	Presser Foot (hinged), complete, Nos. 197f, 233d, 42169, 42268 to 42270 and 62527
1324c	5591	Presser Foot Screw
39541	2272	" " " Washer
42069	5576	" Lever
42376	---	" " 42069 with 42045
42045	5542	" " Hinge Stud
1120c	5591	" " " " Set Screw
42070	2272	" " Lifter
85d	2277	" " " Hinge Screw
1377c	2277	" " Screw Stud (eccentric)
1547j	5543	" " " " Nut
42071	2272	" " Spring
1378d	2277	Pressure Regulating Thumb Screw
132631	2276	Spreader
197d	5556	" Screw
2102	5556	Tension (looper, left hand) Disc
1560c	5556	" (" " ") Regulating Thumb Nut
828c	5556	" (" " ") Screw Stud
42418	---	" (" " ") " " 828c with 1560c
42121	5556	" (" " ") Spring
2102	5556	" (looper, right hand) Disc
1560c	5556	" (" " ") Regulating Thumb Nut
828c	5556	" (" " ") Screw Stud
42418	---	" (" " ") " " 828c with 1560c
10148	5556	" (" " ") Spring
17547	5556	" (" " ") Thread Guide
2102	5556	" (needle thread) Disc
1560c	5556	" (" ") Regulating Thumb Nut
916c	5556	" (" ") Screw Stud
44209	---	" (" ") " " 916c with 1560c

No.	Plate	Name					
10148	5556	Tension (needle thread) Spring
42082	5556	" (" ") Thread Guide
42242	7388	Thread (looper, left hand) Eyelet
233d	5530	" (" " ") " Screw
42081	5556	" (" " ") Tube
462c	5529	" (" " ") " Set Screw
42093	5556	" (looper, right hand) Staple
190d	5556	" (" " ") " Screw
42127	5556	" (" " ") Take-up
197d	5556	" (" " ") " Screw
42096	5556	" (needle) Eyelet
217j	5556	" (") " Screw
42128	2271	" (") Take-up
197d	5556	" (") " Screw
42272	5595	Throat Plate
742f	2277	" " Screw
*15404	---	Trade Mark
15405	---	" " Rivet

PARTS COMPLETE
FOR
No. 81K3 MACHINE

FOR TRIMMING, OVEREDGING AND CLOSING SEAMS IN KNIT GOODS. HAS AUXILIARY FEED TO PREVENT FULLING OR "BELLING" THE EDGES WHILE STITCHING. BIGHT ADJUSTABLE FROM $\frac{1}{8}$ " TO $\frac{3}{8}$ ". THREE-THREAD STITCH. FOOT LIFTER.

No.	Plate	Name
*42484	—	Arm with 15404, two each 462c, 624c, 15405, 42253 and 42487 ...
4389	5543	" Dowel Pin ...
949e	2277	" Screw ...
42001	5576	Balance Wheel, 2 $\frac{3}{16}$ " pulley, with 424c and 1354c ...
1354c	2277	" " Position Screw ...
424c	2277	" " Set Screw ...
*42145	—	Cloth Plate ...
42003	5526	" " Extension (lower) ...
229e	2277	" " " (") Screw ...
42108	5526	" " " (upper) ...
229e	2277	" " " (") Screw ...
42005	5526	" " Lock Spring ...
236c	2277	" " " " Screw ...
42146	—	Cloth Plate, complete, Nos. 42003, 42005, 42108, 42145, two 236c and five 229e ...
1437d	2277	Cloth Plate Hinge Screw ...
1655e	2277	" " " " Nut ...
42147	5557	Feed (back) Bar ...
61c	5590	" (") " Hinge Screw ...
42148	5557	" (") Connecting Link ...
1132c	5557	" (") " " Hinge Screw ...
42149	5533	" (") Dog (3 teeth, 16 teeth to the inch) ...
203d	5591	" (") " Screw ...
42150	5557	" (") Regulator ...
1132c	5557	" (") " Hinge Screw ...
190d	5556	" (") " Set Screw ...
1444c	5557	" (") " Thumb Screw ...

No.	Plate	Name
42151	5590	Feed (front) Bar with 1253c ...
42007	5529	" (") " Hinge Pin ...
1253c	5529	" (") " " Set Screw ...
42008	5529	" (") Connecting Rod with 42009 and two 1057c ...
*42371	—	" (") " " 42008 with 1373c and 1520c ...
*42009	—	" (") " " Cap ...
1057c	5529	" (") " " Screw ...
1373c	5529	" (") " " Hinge Screw ...
1520c	5529	" (") " " " Nut ...
42152	5533	" (") Dog (17 teeth, 16 teeth to the inch) ...
190d	5556	" (") " Screw ...
42011	5529	" (") Eccentric with two 453c ...
42153	2265	" (") " Cover ...
207d	5529	" (") " " Screw ...
453c	5529	" (") " Set Screw ...
42012	5529	" (") Lifting Eccentric with two 462c ...
42013	5529	" (") " " Connection ...
462c	5529	" (") " " Set Screw ...
1374c	5530	" (") Regulating Screw Stud ...
1680c	5530	" (") " " " Nut ...
42290	5530	" (") " " " Washer ...
42014	5530	" (") Regulator with 233j and two 1259c ...
42015	5529	" (") " Connection with 1012c ...
*42368	—	" (") " " 42015 with 1373c and 1520c ...
1012e	5529	" (") " " Adjusting Screw ...
1373c	5529	" (") " " Hinge Screw ...
1520c	5529	" (") " " " Nut ...
42016	5530	" (") " Hinge Stud ...
42017	5529	" (") " Indicator ...
42018	5530	" (") " " Plate ...
337d	5530	" (") " " " Screw ...
207d	5529	" (") " " Screw ...
1259c	5530	" (") " Set Screw ...
233j	5530	" (") " Stop Screw ...
42154	5557	" (") Rock Shaft ...
42155	—	Feed (front) Rock Shaft, complete, Nos. 42021 and 42154 ...
42021	5530	Feed (front) Rock Shaft Crank with 157e ...
157e	5530	" (") " " " Clamping Screw ...
42098	5530	" (") " " Hinge Pin ...
42079	5530	" (") " " " Bushing ...
1036c	5530	" (") " " " " Set Screw ...
*42022	—	Frame ...
42023	5576	" Rotary Shaft ...
42024	5576	" " " Bushing (front) ...
1036c	5530	" " " " (") Set Screw ...

No. 81K3 MACHINE PARTS

No.	Plate	Name
42025	2272	Frame Rotary Shaft Crank with 1259c and 1375c ...
1375c	2277	" " " " Position Screw ...
1259c	5530	" " " " Set Screw ...
42026	5576	" " " Flanged Bushing (back) with 54967 ...
54967	7403	" " " " (") Oil Pad (braided cotton)
1036c	5530	" " " " (") Set Screw ...
42367	5591	" " " Front Bearing Oil Pad (braided cotton) ...
132560	2265	Frame Side Cover (left) with 132701 ...
132701	2268	" " " (") Handle ...
330w	2277	" " " (") Screw ...
42028	5526	" " " (right, hinged) ...
42101	5543	" " " (") Lock Spring ...
330w	2277	" " " (") Screw ...
42029	5576	" Top Cover ...
132650	2268	" " " Extension ...
42102	5543	" " " " Holder ...
283w	5543	" " " " Thumb Screw ...
19044	5539	" " " " " Washer ...
176d	5543	" " " " Screw ...
742f	2277	" " " " Screw ...
42111	5542	Knife (movable) ...

NOTE.—Two No. 42111 are sent with this machine.

42112	5542	Knife (movable) Gib ...
42035	5542	" (") Holder ...
42113	—	" (") " 42035 with 133f, 42037, 42040, 42112 and two 404d
42037	5542	" (") " Cap ...
404d	5542	" (") " " Screw ...
42038	5542	" (") " Guide with 336f ...
42039	5542	" (") " " Plate ...
621d	5542	" (") " " " Screw ...
336f	5542	" (") " " Set Screw ...
133f	5542	" (") " " Screw ...
42040	5542	" (") " " Extension Pin ...
42041	5542	" (") " " Spring ...
42042	5542	" (") " Lever ...
42043	5542	" (") " Connection with 42044 and two 175e ...
*42369	—	" (") " " 42043 with 1373c and 1520c
*42044	—	" (") " " Cap ...
175e	5542	" (") " " " Screw ...
1373c	5529	" (") " " Hinge Screw ...
1520c	5529	" (") " " " Nut ...

No. 81K3 MACHINE PARTS

No.	Plate	Name
42045	5542	Knife (movable) Lever Hinge Stud ...
1229c	5542	" (") " " " Set Screw ...
42046	5543	" (stationary) with 42049 ...

NOTE.—Two No. 42046 are sent with this machine.

42048	5543	Knife (stationary) Clamping Stud ...
1534d	5543	" (") " " Thumb Nut ...
132766	2267	" (") Holder ...
1376c	5543	" (") " Regulating Thumb Screw ...
1101c	5543	" (") " " Screw ...
440f	5543	" (") " " Stop Screw ...
1547j	5543	" (") " " " Nut ...
42049	5543	" (") Stud ...
42114	2272	Looper (left hand) ...
132870	2273	" (" ") Lever with 50117c ...
*42318	—	" (" ") " 132870 with 42053 ...
42052	2271	" (" ") " Connecting Link ...
*42384	—	" (" ") " " " 42052 with two each 1520c and 50562c
50562c	20795	" (" ") " " " Hinge Screw ...
1520c	5529	" (" ") " " " " Nut ...
42053	2272	" (" ") " " Hinge Stud ...
1036c	5530	" (" ") " " " Set Screw ...
50117c	2276	" (" ") Set Screw ...
42166	2272	" (right hand) ...
42073	2271	" (" ") and Spreader Lever with 1259c ...
*42330	—	" (" ") " " " 42073 with 233d, 42078 and 42242
42074	2271	" (" ") " " " Ball Stud ...
1259c	5530	" (" ") " " " " Set Screw ...
42075	2271	" (" ") " " " Connection with 42059, 42076 and four 896c
42416	—	" (" ") " " " Connection 42075 with 42074
42382	—	" (" ") " " " " 42416 with 42025
42380	—	" (" ") " " " " 42382 with 171f and 42077
*42076	—	" (" ") " " " Connection Cap (lower)
896c	20795	" (" ") " " " " (") Screw
*42059	—	" (" ") " " " " Cap (upper)
896c	20795	" (" ") " " " " " (") Screw
42077	2271	" (" ") " " " " Guide ...
171f	5544	" (" ") " " " " " Screw

No.	Plate	Name
42403	2273	Looper (right hand) and Spreader Lever Connection Oil Tube and Bracket with 29599
29599	2272	" (" ") " " " Connection Oil Tube
42078	2271	" (" ") " " " Packing (felt)
42079	5530	" (" ") " " " Hinge Pin ...
1259c	5530	" (" ") " " " " Bushing ...
197d	5556	" (" ") Screw Set Screw
42054	5544	Needle Bar ...
42253	5544	" " Bushing ...
462c	5544	" " " Set Screw ...
42061	5544	" " Connecting Bracket with 187d and 223f ...
187d	5544	" " " Clamping Screw ...
42055	5544	" " Link ...
*42335	—	" " " " 42055 with 42061, 42104 and two 40247
40247	5544	" " " " Hinge Pin ...
223f	5544	" " " " " " " Set Screw for 42061 ...
904c	5544	" " " " " " " " 42104 ...
42057	5544	" " " Rod with 42076, 132878 and four 896c ...
*42383	—	" " " " 42057 with 42074 ...
*42374	—	" " " " 42383 with 42023 ...
*42076	—	" " " " Cap (lower) ...
896c	20795	" " " " " (") Screw ...
*132878	—	" " " " " (upper) ...
896c	20795	" " " " " (") Screw ...
42077	2271	" " " " Guide ...
171f	5544	" " " " " Screw ...
42103	5544	" " Crank (back) with 1258c and two 1259c ...
42074	2271	" " " (") Ball Stud ...
1259c	5530	" " " (") " " Set Screw ...
1259c	5530	" " " (") Position Screw ...
1258c	5544	" " " (") Set Screw ...
42104	5544	" " " (front) with 904c, 1258c and 1259c ...
1259c	5530	" " " (") Position Screw ...
1258c	5544	" " " (") Set Screw ...
42105	5544	" " " Shaft ...
42487	20795	" " " " Bushing ...
624c	20800	" " " " " Set Screw ...
42115	5544	" " Thread Retainer Bracket ...
228d	5544	" " " " " Screw ...
42483	20795	" " " " Disc ...
93c	5544	" " " " Screw ...
10107	5544	" " " " Spring ...
1728c	5544	" Clamping Nut ...

No.	Plate	Name
42066	5544	Needle Guard ...
171f	5544	" " Screw ...
42157	—	Presser Foot Body ...
42158	5599	" " Chaining-off Finger (narrow bight) ...
42190	5599	" " " " (wide bight) for 42161 ...
42500	—	" " " " for 132663 ...
42288	5599	" " " " " 1/8" bight ...
233d	5530	" " " " Screw ...
9320	—	" " Hinge Pin ...
42159	—	" " Plate for 42161 ...
42405	—	" " " " 132663 ...
14058	2276	" " Spring ...
42160	2273	" " " Adjusting Pin ...
464c	2276	" " " " " Set Screw ...
132663	2269	Presser Foot (spring, hinged), complete, Nos. 233d, 464c, 9320, 14058, 42157, 42160, 42405 and 42500 ...
42161	5599	Presser Foot (spring, hinged), complete, Nos. 233d, 464c, 9320, 14058 and 42157 to 42160 ...
1324c	5591	Presser Foot Screw ...
39541	2272	" " " Washer ...
42069	5576	" Lever ...
42376	—	" " 42069 with 42045 ...
42045	5542	" " Hinge Stud ...
1120c	5591	" " " " Set Screw ...
42070	2272	" " Lifter ...
85d	2277	" " " Hinge Screw ...
1377c	2277	" " Screw Stud (eccentric) ...
1547j	5543	" " " " Nut ...
42071	2272	" " Spring ...
1378d	2277	Pressure Regulating Thumb Screw ...
132631	2276	Spreader ...
197d	5556	" Screw ...
2102	5556	Tension (looper, left hand) Disc ...
1560c	5556	" (" " ") Regulating Thumb Nut ...
828c	5556	" (" " ") Screw Stud ...
42418	—	" (" " ") " " 828c with 1560c ...
42121	5556	" (" " ") Spring ...
2102	5556	" (looper, right hand) Disc ...
1560c	5556	" (" " ") Regulating Thumb Nut ...
828c	5556	" (" " ") Screw Stud ...
42418	—	" (" " ") " " 828c with 1560c ...
10148	5556	" (" " ") Spring ...
17547	5556	" (" " ") Thread Guide ...

No. 81K3 MACHINE PARTS

No.	Plate	Name
2102	5556	Tension (needle thread) Disc
1560c	5556	" (" ") Regulating Thumb Nut
916c	5556	" (" ") Screw Stud
44209	—	" (" ") " " 916c with 1560c
10148	5556	" (" ") Spring
42082	5556	" (" ") Thread Guide
42242	7388	Thread (looper, left hand) Eyelet
233d	5530	" (" " ") " Screw
42124	5590	" (" " ") Pull-off
42125	5590	" (" " ") " Eyelet
233d	5530	" (" " ") " " Screw
42084	5556	" (" " ") Tube
462c	5529	" (" " ") " Set Screw
42093	5556	" (looper, right hand) Staple
190d	5556	" (" " ") " Screw
42127	5556	" (" " ") Take-up
197d	5556	" (" " ") " Screw
42096	5556	" (needle) Eyelet
217j	5556	" (") " Screw
42162	2266	" (") Take-up
197d	5556	" (") " Screw
42163	5533	Throat Plate
742f	2277	" " Screw
*15404	—	Trade Mark
15405	—	" " Rivet

Fittings

FOR 81K3 MACHINE FOR BALBRIGGAN

No.	Plate	Name
42149	5533	Feed (back) Dog (3 teeth, 16 teeth to the inch)
42262	5533	" (front) " (21 teeth, 16 teeth to the inch)
42158	5599	Presser Foot Chaining-off Finger (narrow bight)
42190	5599	" " " " (wide bight)
42288	5599	" " " " for $\frac{1}{8}$ " bight
233d	5530	" " " " Screw
42159	—	" " Plate (back)
9320	—	" " " (") Hinge Pin
14058	2276	" " " (") Spring
42160	2273	" " " (") " Adjusting Pin
464c	2276	" " " (") " " " Set Screw
42263	—	" " " (front)
42161	7397	" " " (") Hinge Pin
42264	—	" " Shank
42265	5599	Presser Foot (spring, hinged), complete, Nos. 233d, 464c, 9320, 14058, 42158 to 42160, 42263, 42264 and 42161
42164	5533	Throat Plate for 42149 and 42262

FOR LIGHT AND MEDIUM-WEIGHT KNIT GOODS

No.	Plate	Name
42149	5533	Feed (back) Dog (3 teeth, 16 teeth to the inch)
42152	5533	" (front) " (17 teeth, 16 teeth to the inch)
42157	—	Presser Foot Body
42500	—	" " Chaining-off Finger
233d	5530	" " " " Screw
9320	—	" " Hinge Pin
42405	—	" " Plate
14058	2276	" " Spring
42160	2273	" " " Adjusting Pin
464c	2276	" " " " " " Set Screw
132663	2269	Presser Foot (spring, hinged), complete, Nos. 233d, 464c, 9320, 14058, 42157, 42160, 42405 and 42500
42163	5533	Throat Plate for 42149 and 42152

No. 81K4 MACHINE

DIFFERS FROM No. 81K3 IN HAVING HAND LEVER FOR QUICK ADJUSTMENT OF BIGHT.

This machine is the same as No. 81K3 with the following exceptions:

No.	Plate	Name
*42173	—	Frame, in place of 42022 ...
42200	2267	Knife (stationary) Holder Regulating Lever ...
42176	2267	" (") " " " Friction Washer ...
42204	2267	" (") " " " Indicator ...
236f	2277	" (") " " " " Screw ...
42201	2267	" (") " " " Latch ...
42202	2267	" (") " " " " Bracket ...
213f	2276	" (") " " " " " Screw ...
1210f	2276	" (") " " " " Hinge Screw ...
42203	2267	" (") " " " " Spring ...
42177	2267	" (") " " " " Slide Block ...
1250f	2276	" (") " " " " " Stud
35c	2277	" (") " " Screw, in place of 1101c ...
42178	—	Presser Foot Body, in place of 42157 ...
42179	5599	" " Chaining-off Finger, in place of 42158 ...
42180	5599	" " " " Regulating Lever ...
104c	5599	" " " " " Hinge Screw ...
42181	5599	Presser Foot (spring hinged), complete, Nos. 101c, 161c, 9320, 14058, 42159, 42160 and 42178 to 42180, in place of 132663
42164	5533	Throat Plate for 42149 and 42152, for narrow bight on ballbriggan and closely woven goods, in place of 42163 ...

PARTS COMPLETE

FOR

No. 81K6 MACHINE

FOR TRIMMING, OVEREDGING AND BLIND STITCH HEMMING OR WELTING IN KNIT UNDERWEAR. HAS AUXILIARY FEED TO PREVENT FULLING OR "BELLING" THE EDGES WHILE STITCHING. TWO-THREAD STITCH. FOOT LIFTER.

No.	Plate	Name
*42484	—	Arm with 15104, two each 462c, 624c, 15105, 42253 and 42487 ...
4389	5543	" Dowel Pin ...
949c	2277	" Screw ...
42004	5576	Balance Wheel, 2 $\frac{3}{16}$ " pulley, with 424c and 1354c ...
1354c	2277	" " Position Screw ...
424c	2277	" " Set Screw ...
*42145	—	Cloth Plate ...
42146	—	Cloth Plate, complete, Nos. 42003, 42005, 42108, 42145, two 236c and five 229c ...
42003	5526	Cloth Plate Extension (lower) ...
229c	2277	" " " (") Screw ...
42108	5526	" " " (upper) ...
229c	2277	" " " (") Screw ...
1437d	2277	" " Hinge Screw ...
1655c	2277	" " " " Nut ...
42005	5526	" " Lock Spring ...
236c	2277	" " " " Screw ...
42147	5557	Feed (back) Bar ...
61c	5590	" (") " Hinge Screw ...
42148	5557	" (") Connecting Link ...
1132c	5557	" (") " " Hinge Screw ...
42149	5533	" (") Dog (3 teeth, 16 teeth to the inch) ...
203d	5591	" (") " Screw ...
42150	5557	" (") Regulator ...
1132c	5557	" (") " Hinge Screw ...
190d	5556	" (") " Set Screw ...
1414c	5557	" (") " Thumb Screw ...

No.	Plate	Name
42151	5590	Feed (front) Bar with 1253c
42007	5529	" (") " Hinge Pin
1253c	5529	" (") " " " Set Screw
42008	5529	" (") Connecting Rod with 42009 and two 1057c
*42371	---	" (") " " 42008 with 1373c and 1520c
*42009	---	" (") " " Cap
1057c	5529	" (") " " " Screw
1373c	5529	" (") " " Hinge Screw
1520c	5529	" (") " " " Nut
42182	5539	" (") Dog (17 teeth, 16 teeth to the inch)
190d	5556	" (") " Screw
42011	5529	" (") Eccentric with two 453c
42153	2265	" (") " Cover
207d	5529	" (") " " Screw
453c	5529	" (") " " Set Screw
42012	5529	" (") Lifting Eccentric with two 162c
42013	5529	" (") " " Connection
462c	5529	" (") " " Set Screw
1374c	5530	" (") Regulating Screw Stud
1680c	5530	" (") " " " Nut
42290	5530	" (") " " " Washer
42014	5530	" (") Regulator with 233j and two 1259c
42015	5529	" (") " " Connection with 1012c
*42368	---	" (") " " 42015 with 1373c and 1520c
1012c	5529	" (") " " Adjusting Screw
1373c	5529	" (") " " Hinge Screw
1520c	5529	" (") " " " Nut
42016	5530	" (") " Hinge Stud
42017	5529	" (") " Indicator
42018	5530	" (") " " Plate
337d	5530	" (") " " " Screw
207d	5529	" (") " " " Screw
1259c	5530	" (") " " Set Screw
233j	5530	" (") " " Stop Screw
42154	5557	" (") Rock Shaft
42155	---	Feed (front) Rock Shaft, complete, Nos. 42021 and 42154
42021	5530	Feed (front) Rock Shaft Crank with 157c
157c	5530	" (") " " " Clamping Screw
42098	5530	" (") " " Hinge Pin
42079	5530	" (") " " " Bushing
1036c	5530	" (") " " " " Set Screw
*42022	---	Frame
42023	5576	" Rotary Shaft
42024	5576	" " " Bushing (front)
1036c	5530	" " " " (") Set Screw

No.	Plate	Name
42025	2272	Frame Rotary Shaft Crank with 1259c and 1375c
1375c	2277	" " " " Position Screw
1259c	5530	" " " " Set Screw
42026	5576	" " " Flanged Bushing (back) with 54967
54967	7103	" " " " " (") Oil Pad (braided cotton)
1036c	5530	" " " " " (") Set Screw
42367	5591	" " " Front Bearing Oil Pad (braided cotton)
132560	2265	" Side Cover (left) with 132701
132701	2268	" " " (") Handle
330w	2277	" " " (") Screw
42028	5526	" Side Cover (right, hinged)
42101	5543	" " " (") Lock Spring
330w	2277	" " " (") Screw
42029	5576	" Top Cover
132650	2268	" " " Extension
42102	5543	" " " " Holder
42324	---	" " " " " 42102 with 42101, 42153, 132650, two each 176d and 207d
283w	5543	" " " " " Holder Thumb Screw
19014	5539	" " " " " " " Washer
176d	5543	" " " " " Screw
712f	2277	" " " " Screw
42111	5542	Knife (movable)
<i>NOTE: Two No. 42111 are sent with this machine.</i>		
42112	5542	Knife (movable) Gily
42035	5542	" (") Holder
42113	---	" (") " 42035 with 1331, 42037, 42040, 42112 and two 404d
42037	5542	" (") " Cap
404d	5542	" (") " " Screw
42038	5542	" (") " Guide with 336f
42039	5542	" (") " " Plate
621d	5542	" (") " " " Screw
336f	5542	" (") " " " Set Screw
133f	5542	" (") " " Screw
42040	5542	" (") " " Extension Pin
42041	5542	" (") " Spring
42042	5542	" (") Lever
42043	5542	" (") " Connection with 42044 and two 175c
*42369	---	" (") " " 42043 with 1373c and 1520c
*42044	---	" (") " " Cap
175c	5542	" (") " " " Screw
1373c	5529	" (") " " Hinge Screw
1520c	5529	" (") " " " Nut

No.	Plate	Name
42045	5542	Knife (movable) Lever Hinge Stud
1229c	5542	" (") " " " Set Screw
42046	5543	" (stationary) with 42049
<i>NOTE.—Two No. 42046 are sent with this machine.</i>		
42048	5543	Knife (stationary) Clamping Stud
1534d	5543	" (") " " Thumb Nut
132766	2267	" (") Holder
1376c	5543	" (") " Regulating Thumb Screw
1101c	5543	" (") " Screw
440f	5543	" (") " Stop Screw
1547j	5543	" (") " " Nut
42049	5543	" (") Stud
42114	2272	Looper (left hand)
132870	2273	" (" ") Lever with 50117c
*42318	---	" (" ") " 132870 with 42053
42052	2271	" (" ") " Connecting Link
*42384	---	" (" ") " " 42052 with two each 1520c and 50562c
50562c	20795	" (" ") " " Hinge Screw
1520c	5529	" (" ") " " " Nut
42053	2272	" (" ") " Hinge Stud
1036c	5530	" (" ") " " Set Screw
50117c	2276	" (" ") Set Screw
42166	2272	" (right hand)
42073	2271	" (" ") and Spreader Lever with 1259c
*42330	---	" (" ") " " 42073 with 233d, 42078 and 42242
42074	2271	" (" ") " " Ball Stud
1259c	5530	" (" ") " " Set Screw
42075	2271	" (" ") " " Connection with 42059, 42076 and four 896c
42416	---	" (" ") " " Connection 42075 with 42074
42382	---	" (" ") " " 42416 with 42025
42380	---	" (" ") " " 42382 with 171f and 42077
*42076	---	" (" ") " " Connection Cap (lower)
896c	20795	" (" ") " " " (") Screw
*42059	---	" (" ") " " Cap (upper)
896c	20795	" (" ") " " " (") Screw
42077	2271	" (" ") " " Guide
171f	5544	" (" ") " " Screw

No.	Plate	Name
42103	2273	Looper (right hand) and Spreader Lever Connection Oil Tube and Bracket with 29599
29599	2272	" (" ") " " " Connection Oil Tube Packing (felt)
42078	2271	" (" ") " " Hinge Pin
42079	5530	" (" ") " " Bushing
1259c	5530	" (" ") " " " Set Screw
197d	5556	" (" ") Screw
42054	5544	Needle Bar
42253	5544	" " Bushing
462c	5544	" " " Set Screw
42061	5544	" " Connecting Bracket with 187d and 2230
187d	5544	" " " " Clamping Screw
42055	5544	" " " Link
*42335	---	" " " 42055 with 42061, 42104 and two 40247
40247	5544	" " " Hinge Pin
223f	5544	" " " Set Screw for 42061
904c	5544	" " " " " 42104
42057	5544	" " " Rod with 42076, 132878 and four 896c
*42383	---	" " " 42057 with 42074
*42374	---	" " " 42383 with 42023
*42076	---	" " " Cap (lower)
896c	20795	" " " " (") Screw
*132878	---	" " " " (upper)
896c	20795	" " " " (") Screw
42077	2271	" " " Guide
171f	5544	" " " " Screw
42103	5544	" " Crank (back) with 1258c and two 1259c
42074	2271	" " " (") Ball Stud
1259c	5530	" " " (") " Set Screw
1259c	5530	" " " (") Position Screw
1258c	5544	" " " (") Set Screw
42104	5544	" " " (front) with 904c, 1258c, and 1259c
1259c	5530	" " " (") Position Screw
1258c	5544	" " " (") Set Screw
42105	5544	" " " Shaft
42487	20795	" " " Bushing
624c	20800	" " " " Set Screw
42115	5544	" " Thread Retainer Bracket
228d	5544	" " " " Screw
42483	20795	" " " Disc
93c	5544	" " " Screw
10107	5544	" " " Spring
1728c	5544	" Clamping Nut

No.	Plate	Name
42066	5544	Needle Guard ...
171f	5544	" " Screw ...
42183	—	Presser Foot Body ...
42184	5539	" " Chaining-off Finger ...
233d	5530	" " " " " Screw ...
9320	—	" " Hinge Pin ...
42159	—	" " Plate ...
14058	2276	" " Spring ...
42160	2273	" " " " Adjusting Pin ...
464c	2276	" " " " " Set Screw ...
42185	5539	Presser Foot (spring, hinged), complete, Nos. 233d, 464c, 9320, 14058, 42159, 42160, 42183 and 42184 ...
1324c	5591	Presser Foot Screw ...
39541	2272	" " " Washer ...
42069	5576	" " Lever ...
42376	—	" " " 42069 with 42045 ...
42045	5542	" " Hinge Stud ...
1120c	5591	" " " " " Set Screw ...
42070	2272	" " Lifter ...
85d	2277	" " " Hinge Screw ...
1377c	2277	" " Screw Stud (eccentric) ...
1547j	5543	" " " " Nut ...
42071	2272	" " Spring ...
1378d	2277	Pressure Regulating Thumb Screw ...
132631	2276	Spreader ...
197d	5556	" " Screw ...
2102	5556	Tension (looper, left hand) Disc ...
1560c	5556	" (" " ") Regulating Thumb Nut ...
828c	5556	" (" " ") Screw Stud ...
42418	—	" (" " ") " " 828c with 1560c ...
42121	5556	" (" " ") Spring ...
2102	5556	" (" " right hand) Disc ...
1560c	5556	" (" " ") Regulating Thumb Nut ...
828c	5556	" (" " ") Screw Stud ...
42418	—	" (" " ") " " 828c with 1560c ...
10148	5556	" (" " ") Spring ...
17547	5556	" (" " ") Thread Guide ...
2102	5556	" (needle thread) Disc ...
1560c	5556	" (" " ") Regulating Thumb Nut ...
916c	5556	" (" " ") Screw Stud ...
44209	—	" (" " ") " " 916c with 1560c ...
10148	5556	" (" " ") Spring ...
42082	5556	" (" " ") Thread Guide ...

No.	Plate	Name
42242	—	Thread (looper, left hand) Eyelet ...
233d	5530	" (" " ") " Screw ...
42124	5590	" (" " ") Pull-off ...
42125	5590	" (" " ") " " Eyelet ...
233d	5530	" (" " ") " " Screw ...
42084	5556	" (" " ") Tube ...
462c	5529	" (" " ") " Set Screw ...
42093	5556	" (looper, right hand) Staple ...
190d	5556	" (" " ") " Screw ...
42127	5556	" (" " ") Take-up ...
197d	5556	" (" " ") " Screw ...
42096	5556	" (needle) Eyelet ...
217j	5556	" (") " Screw ...
42162	2266	" (") Take-up ...
197d	5556	" (") " Screw ...
42186	5539	Throat Plate ...
42452	7403	" " for heavy work ...
742f	2277	" " Screw ...
*15404	—	Trade Mark ...
15405	—	" " Rivet ...

PARTS COMPLETE
FOR
No. 81K7 MACHINE

FOR SEAMING AND INSERTING SLEEVES IN HEAVY SWEATERS, HAS TRIMMER AND AUXILIARY FEED MECHANISM, HIGH LIFT, FOOT LIFTER. THIS MACHINE IS REGULARLY FITTED WITH No. 42299 GUIDE FOR BLIND STITCH HEMMING AND No. 42300 GUIDE FOR SELVAGE EDGES. No. 42303 GUIDE COMPLETE FOR JOINING BORDERS WILL BE SUBSTITUTED FOR EITHER No. 42299 OR No. 42300 IF SO SPECIFIED UPON ORDER.

No.	Plate	Name
*42485	—	Arm with 15404, two each 462c, 624c, 15405, 42253 and 42487
4389	5543	" Dowel Pin ...
949c	2277	" Screw ...
42001	5576	Balance Wheel, 2 $\frac{3}{8}$ " pulley, with 424c and 1354c ...
1354c	2277	" " Position Screw ...
424c	2277	" " Set Screw ...
42292	2264	Cloth Plate ...
42293	—	Cloth Plate, complete, Nos. 42005, 42108, 42292, 42294, two 236c and five 229c ...
42294	5598	Cloth Plate Extension (lower) ...
229c	2277	" " " (") Screw ...
42108	5526	" " " (upper) ...
229c	2277	" " " (") Screw ...
1437d	2277	" " Hinge Screw ...
1655c	2277	" " " " Nut ...
42005	5526	" " Lock Spring ...
236c	2277	" " " " Screw ...
42147	5557	Feed (back) Bar ...
61c	5590	" (") " Hinge Screw ...
42148	5557	" (") Connecting Link ...
1132c	5557	" (") " " Hinge Screw ...
42295	7377	" (") Dog ...
203d	5591	" (") " Screw ...
42150	5557	" (") Regulator ...
1132c	5557	" (") " Hinge Screw ...
190d	5556	" (") " Set Screw ...

No.	Plate	Name
1444c	5557	Feed (back) Regulator Thumb Screw ...
42296	2268	" (front) Bar with 1253c ...
42007	5529	" (") " Hinge Pin ...
1253c	5529	" (") " " " Set Screw ...
42008	5529	" (") Connecting Rod with 42009 and two 1057c ...
*42371	—	" (") " " 42008 with 1373c and 1520c ...
*42009	—	" (") " " " Cap ...
1057c	5529	" (") " " " Screw ...
1373c	5529	" (") " " Hinge Screw ...
1520c	5529	" (") " " " Nut ...
42297	7377	" (") Dog, 7 teeth ...
42460	2270	" (") " (9 teeth, 8 teeth to the inch), for coarse, loosely knitted fabrics ...
190d	5556	" (") Dog Screw ...
42011	5529	" (") Eccentric with two 453c ...
42298	2265	" (") " Cover ...
207d	5529	" (") " " Screw ...
453c	5529	" (") " Set Screw ...
42208	5596	" (") Lifting Eccentric with two 462c ...
12013	5529	" (") " " Connection ...
462c	5529	" (") " " Set Screw ...
1374c	5530	" (") Regulating Screw Stud ...
1680c	5530	" (") " " " Nut ...
42290	5530	" (") " " " Washer ...
42014	5530	" (") Regulator with 233j and two 1259c ...
42015	5529	" (") " Connection with 1012c ...
*42368	—	" (") " " 42015 with 1373c and 1520c ...
1012c	5529	" (") " " Adjusting Screw ...
1373c	5529	" (") " " Hinge Screw ...
1520c	5529	" (") " " " Nut ...
42016	5530	" (") " Hinge Stud ...
1259c	5530	" (") " Set Screw ...
233j	5530	" (") " Stop Screw ...
42154	5557	" (") Rock Shaft ...
42155	—	Feed (front) Rock Shaft, complete, Nos. 42021 and 42154 ...
42021	5530	Feed (front) Rock Shaft Crank with 157c ...
157c	5530	" (") " " " Clamping Screw ...
42098	5530	" (") " " Hinge Pin ...
42079	5530	" (") " " " Bushing ...
1036c	5530	" (") " " " Set Screw ...
*42209	—	Frame ...
42266	2263	" Rotary Shaft ...
42024	5576	" " " Bushing (front) ...
1036c	5530	" " " " (") Set Screw ...

No.	Plate	Name
42211	5596	Frame Rotary Shaft Crank with 1036c and 1375c ...
1375c	2277	" " " " Position Screw ...
1036c	5530	" " " " Set Screw ...
42026	5576	" " " " Flanged Bushing (back) with 54967 ...
54967	7403	" " " " (") Oil Pad (braided cotton)
1036c	5530	" " " " (") Set Screw ...
42367	5591	" " " " Front Bearing Oil Pad (braided cotton) ...
132560	2265	" Side Cover (left) with 132701 ...
132701	2268	" " " " (") Handle ...
330w	2277	" " " " (") Screw ...
42028	5526	" " " " (right, hinged) ...
42101	5543	" " " " (") Lock Spring ...
330w	2277	" " " " (") Screw ...
42029	5576	" Top Cover ...
42212	5596	" " " " Extension ...
42102	5543	" " " " " Holder ...
42319	—	" " " " " 42102 with 42101, 42212, 42298, two each 176j and 207d
283w	5543	" " " " " Holder Thumb Screw ...
19044	5539	" " " " " " " " Washer ...
176d	5543	" " " " " " " " Screw ...
742f	2277	" " " " " " " " Screw ...
42299	7378	Guide, for blind stitch hemming ...
42300	7378	" " for selvage edge ...
42301	7378	" " (lower) ...
42302	7378	" " (upper) ...
42303	—	Guide, complete, for joining borders to cut edges of sweaters, Nos. 42301 and 42302 ...
42304	7378	Guide Holder ...
1209c	5539	" " " " Screw ...
38635	7378	" " " " Washer ...
193f	2277	" " " " Screw ...
7071	5595	" " " " Washer ...
42305	2267	Knife (movable) ...
<i>NOTE.—Two No. 42305 are sent with this machine.</i>		
42306	2267	Knife (movable) Gib ...
132926	2267	" (") Holder ...
132927	—	" (") " 132926 with 133f, 42040, 42306, 132928 and two 220e
132928	—	" (") " " Cap ...
220e	5541	" (") " " " Screw ...
42038	5542	" (") " " Guide with 336f ...

No.	Plate	Name
42039	5542	Knife (movable) Holder Guide Plate ...
621d	5542	" (") " " " " " Screw ...
336f	5542	" (") " " " " " Set Screw ...
133f	5542	" (") " " " " " Screw ...
42040	5542	" (") " " " " " Extension Pin ...
42041	5542	" (") " " " " " Spring ...
42042	5542	" (") " " " " " Lever ...
42217	5560	" (") " " " " " Connection with 42218 and two 175e ...
*42370	—	" (") " " " " " 42217 with 1373c and 1520e
*42218	—	" (") " " " " " Cap ...
175e	5542	" (") " " " " " " " Screw ...
1373c	5529	" (") " " " " " " Hinge Screw ...
1520e	5529	" (") " " " " " " " " Nut ...
42045	5542	" (") " " " " " " Hinge Stud ...
1229c	5542	" (") " " " " " " " " Set Screw ...
42309	20795	" (stationary) with 42049 ...
<i>NOTE. Two No. 42309 are sent with this machine.</i>		
42310	20795	Knife (stationary) Clamping Stud ...
1534d	5543	" (") " " " " " Thumb Nut ...
132767	2267	" (") " " " " " " Holder ...
1376c	5543	" (") " " " " " " " " Regulating Thumb Screw ...
1101c	5543	" (") " " " " " " " " Screw ...
410f	5543	" (") " " " " " " " " Stop Screw ...
1547j	5543	" (") " " " " " " " " Nut ...
42049	5543	" (") " " " " " " " " Stud ...
42219	5560	Looper (left hand) ...
132870	2273	" (" ") " " " " " " " " Lever with 50117c ...
*42318	—	" (" ") " " " " " " " " 132870 with 42053 ...
42052	2271	" (" ") " " " " " " " " Connecting Link ...
*42384	—	" (" ") " " " " " " " " 42052 with two each 1520e and 50562c
50562c	20795	" (" ") " " " " " " " " Hinge Screw ...
1520e	5529	" (" ") " " " " " " " " " " Nut ...
42053	2272	" (" ") " " " " " " " " Hinge Stud ...
1036c	5530	" (" ") " " " " " " " " Set Screw ...
50117c	2276	" (" ") " " " " " " " " Set Screw ...
42220	5560	" (right hand) ...
42073	2271	" (" ") and Spreader Lever with 1259c ...
*42330	—	" (" ") " " " " " " " " 42073 with 233d, 42078 and 42242
42221	5560	" (" ") " " " " " " " " Ball Stud ...
1259c	5530	" (" ") " " " " " " " " " " Set Screw ...
42075	2271	" (" ") " " " " " " " " " " Connection with 42059, 42076 and four 896c
*42076	—	" (" ") " " " " " " " " " " Connection Cap (lower)

No.	Plate	Name
896c	20795	Looper (right hand) and Spreader Lever Connection Cap (lower) Screw
*42059	—	" (" ") " " " " " (upper)
896c	20795	" (" ") " " " " " (") Screw
42077	2271	" (" ") " " " " " Guide ...
171f	5544	" (" ") " " " " " Screw
42403	2273	" (" ") " " " " " Oil Tube
29599	2272	" (" ") " " " " and Bracket with 29599 Connection Oil Tube Packing (felt)
42078	2271	" (" ") " " " " Hinge Pin ...
42079	5530	" (" ") " " " " " Bushing ...
1259c	5530	" (" ") " " " " " Set Screw
197d	5556	" (" ") Screw ...
38534	5560	Needle Bar (hollow) ...
42253	5544	" " Bushing ...
462c	5544	" " " Set Screw ...
42291	5596	" " Connecting Bracket with 223f and 1057c ...
1057c	5529	" " " Clamping Screw ...
42055	5544	" " " Link ...
*42326	—	" " " " 42055 with 42104, 42291 and two 10247
40247	5544	" " " " Hinge Pin ...
223f	5544	" " " " " " " Set Screw for 42291 ...
904c	5544	" " " " " " " " 42104 ...
42057	5544	" " " " Rod with 42076, 132878 and four 896c
*42383	—	" " " " 42057 with 42074 ...
*42373	—	" " " " 42383 with 42266 ...
*42076	—	" " " " Cap (lower) ...
896c	20795	" " " " " (") Screw ...
*132878	—	" " " " " (upper) ...
896c	20795	" " " " " (") Screw ...
42077	2271	" " " " " Guide ...
171f	5544	" " " " " " " Screw ...
42103	5544	" " Crank (back) with 1258c and two 1259c ...
42074	2271	" " " (") Ball Stud ...
1259c	5530	" " " (") " " Set Screw ...
1259c	5530	" " " (") Position Screw ...
1258c	5544	" " " (") Set Screw ...
42104	5544	" " " (front) with 904c, 1258c and 1259c ...
1259c	5530	" " " (") Position Screw ...
1258c	5544	" " " (") Set Screw ...
42105	5544	" " " Shaft ...
42487	20795	" " " " Bushing ...

No.	Plate	Name
624c	20800	Needle Bar Crank Shaft Bushing Set Screw ...
42115	5544	" " Thread Retainer Bracket ...
228d	5544	" " " " " " " Screw ...
42483	20795	" " " " " " Disc ...
93c	5544	" " " " " " Screw ...
10107	5544	" " " " " " Spring ...
1737 4728c 5544 20795		Clamping Nut ...
42066	5544	" Guard ...
171i	5544	" " " Screw ...
42312	—	Presser Foot Body ...
42313	7377	" " Chaining-off Finger ...
233d	5530	" " " " " " Screw ...
9320	—	" " Hinge Pin ...
42314	—	" " Plate ...
42315	7377	" " Smoothing Plate ...
233d	5530	" " " " " " Screw ...
14058	2276	" " Spring ...
42160	2273	" " " Adjusting Pin ...
464c	2276	" " " " " " Set Screw ...
42316	7377	Presser Foot (spring, hinged), complete, Nos. 464c, 9320, 14058, 42160, 42312 to 42315 and two 233d ...
1324c	5591	Presser Foot Screw ...
39541	2272	" " " " Washer ...
42227	2271	" Lever ...
42377	—	" " 42277 with 42045 ...
42045	5512	" " Hinge Stud ...
1120c	5591	" " " " " " Set Screw ...
42070	2272	" " Lifter ...
85d	2277	" " " Hinge Screw ...
1377c	2277	" " Screw Stud (eccentric) ...
1547j	5543	" " " " " " Nut ...
42071	2272	" " Spring ...
1378d	2277	Pressure Regulating Thumb Screw ...
42250	5560	Spreader ...
197d	5556	" " Screw ...
2102	5556	Tension (looper, left hand) Disc ...
1560c	5556	" (" " ") Regulating Thumb Nut ...
828c	5556	" (" " ") Screw Stud ...
12418	—	" (" " ") " " 828c with 1560c ...
42121	5556	" (" " ") Spring ...
2102	5556	" (looper, right hand) Disc ...
1560c	5556	" (" " ") Regulating Thumb Nut ...

No.	Plate	Name
828c	5556	Tension (looper, right hand) Screw Stud
42418	—	" (" " ") " " 828c with 1560c
10148	5556	" (" " ") Spring
17547	5556	" (" " ") Thread Guide
2102	5556	" (needle thread) Disc
1560c	5556	" (" ") Regulating Thumb Nut
916c	5556	" (" ") Screw Stud
44209	—	" (" ") " " 916c with 1560c
2103	5556	" (" ") Spring
42082	5556	" (" ") Thread Guide
42242	7388	Thread (looper, left hand) Eyelet
233d	5530	" (" " ") " Screw
42122	7388	" (" " ") Nipper Spring (lower)
42123	7388	" (" " ") " " (upper)
176d	5543	" (" " ") " " Screw
42124	5590	" (" " ") Pull-off
42125	5590	" (" " ") " Eyelet
233d	5530	" (" " ") " " Screw
42084	5556	" (" " ") Tube
462c	5529	" (" " ") " Set Screw
42126	2266	" (looper, right hand) Pull-off
42093	5556	" (" " ") Staple
190d	5556	" (" " ") " Screw
42127	5556	" (" " ") Take-up
197d	5556	" (" " ") " Screw
42096	5556	" (needle) Eyelet
217j	5556	" (") " Screw
42128	2274	" (") Take-up
197d	5556	" (") " Screw
42317	7377	Throat Plate
742f	2277	" " Screw
*15404	—	Trade Mark
15405	—	" " Rivet

PARTS COMPLETE

FOR

No. 81K11 MACHINE

FOR CLOSING SELVAGE EDGES OF KNIT FABRICS, PRODUCING A
FLAT SEAM. NO TRIMMER. TWO-THREAD STITCH. FOOT
LIFTER.

No.	Plate	Name
*42484	—	Arm with 15404, two each 462c, 624c, 15405, 42253 and 42487
4389	5543	" Dowel Pin
949c	2277	" Screw
42001	5576	Balance Wheel, 2 $\frac{3}{16}$ " pulley, with 424c and 1354c
1354c	2277	" " Position Screw
424c	2277	" " Set Screw
42002	5526	Cloth Plate
42107	—	Cloth Plate, complete, Nos. 42002, 42003, 42005, 42108, two 236c and five 229c
42003	5526	Cloth Plate Extension (lower)
229c	2277	" " " (") Screw
42108	5526	" " " (upper)
229c	2277	" " " (") Screw
1437d	2277	" " Hinge Screw
1655e	2277	" " " " Nut
42005	5526	" " Lock Spring
236c	2277	" " " " Screw
42205	5596	Feed Bar with 1253c
*42333	—	" " 42205 with 42013
42007	5529	" " Hinge Pin
1253c	5529	" " " " Set Screw
42008	5529	" Connecting Rod with 42009 and two 1057c
*42371	—	" " " 42008 with 1373c and 1520c
*42009	—	" " " Cap
1057c	5529	" " " " Screw
1373c	5529	" " " Hinge Screw
1520c	5529	" " " " " Nut
42280	5540	" Dog
190d	5526	" " Screw
42011	5529	" Eccentric with two 453c

No.	Plate	Name
42094	5526	Feed Eccentric Cover ...
42102	5543	" " " Holder ...
283w	5543	" " " " Thumb Screw ...
19044	5539	" " " " " Washer ...
207d	5529	" " " " Screw ...
453c	5529	" " " " Set Screw ...
42012	5529	" Lifting Eccentric with two 462c ...
42013	5529	" " " " Connection ...
462c	5529	" " " " Set Screw ...
1374c	5530	" Regulating Screw Stud ...
1680c	5530	" " " " Nut ...
42290	5530	" " " " Washer ...
42014	5530	" Regulator with 233j and two 1259c ...
42015	5529	" " " " Connection with 1012c ...
*42368	—	" " " " 42015 with 1373c and 1520c ...
1012c	5529	" " " " Adjusting Screw ...
1373c	5529	" " " " Hinge Screw ...
1520c	5529	" " " " " " Nut ...
42016	5530	" " " " Hinge Stud ...
1259c	5530	" " " " Set Screw ...
233j	5530	" " " " Stop Screw ...
42019	5530	" Rock Shaft ...
42020	—	Feed Rock Shaft, complete, Nos. 42019 and 42021 ...
42021	5530	Feed Rock Shaft Crank with 157c ...
157c	5530	" " " " Clamping Screw ...
42098	5530	" " " " Hinge Pin ...
42079	5530	" " " " " " Bushing ...
1036c	5530	" " " " " " " " Set Screw ...
*42022	—	Frame ...
42023	5576	" Rotary Shaft ...
42024	5576	" " " " Bushing (front) ...
1036c	5530	" " " " " (") Set Screw ...
42025	2272	" " " " Crank with 1259c and 1375c ...
1375c	2277	" " " " " " Position Screw ...
1259c	5530	" " " " " " Set Screw ...
42026	5576	" " " " Flanged Bushing (back) with 54967 ...
54967	7403	" " " " " " (") Oil Pad (braided cotton) ...
1036c	5530	" " " " " " (") Set Screw ...
42367	5591	" " " " Front Bearing Oil Pad (braided cotton) ...
132638	2265	" Side Cover (left) with 132701 ...
132701	2268	" " " " (") Handle ...
330w	2277	" " " " (") Screw ...
42028	5526	" " " " (right, hinged) ...

No.	Plate	Name
42192	5560	Frame Side Cover (right) Lock Spring ...
330w	2277	" " " " (") " " Screw ...
330w	2277	" " " " (") Screw ...
42029	5576	" Top Cover ...
712f	2277	" " " " Screw ...
42194	5560	Guide ...
217d	5556	" Screw ...
7071	5595	" " Washer ...
42114	2272	Looper (left hand) ...
132870	2273	" (" ") Lever with 50117c ...
*42318	—	" (" ") " " 132870 with 42053 ...
42052	2271	" (" ") " " Connecting Link ...
*42384	—	" (" ") " " " " 42052 with two each 1520c and 50562c ...
50562c	20795	" (" ") " " " " Hinge Screw ...
1520c	5529	" (" ") " " " " " " Nut ...
42053	2272	" (" ") " " Hinge Stud ...
1036c	5530	" (" ") " " " " Set Screw ...
50117c	2276	" (" ") Set Screw ...
42166	2272	" (right hand) ...
42073	2271	" (" ") and Spreader Lever with 1259c ...
*42330	—	" (" ") " " " " 42073 with 233d, 42078 and 42242 ...
42074	2271	" (" ") " " " " Ball Stud ...
1259c	5530	" (" ") " " " " " " Set Screw ...
42075	2271	" (" ") " " " " Connection with 42059, 42076 and four 896c ...
42416	—	" (" ") " " " " Connection 42075 with 42074 ...
42382	—	" (" ") " " " " " 42416 with 42025 ...
42380	—	" (" ") " " " " " 42382 with 171f and 42077 ...
*42076	—	" (" ") " " " " Connection Cap (lower) ...
896c	20795	" (" ") " " " " " " (") Screw ...
*42059	—	" (" ") " " " " " Cap (upper) ...
896c	20795	" (" ") " " " " " " (") Screw ...
42077	2271	" (" ") " " " " " Guide ...
171f	5544	" (" ") " " " " " " Screw ...
42403	2273	" (" ") " " " " " Oil Tube and Bracket with 29599 ...
29599	2272	" (" ") " " " " " Connection Oil Tube Packing (felt) ...

No.	Plate	Name
42078	2271	Looper (right hand) and Spreader Lever Hinge Pin ...
42079	5530	" (" ") " " " " " " Bushing ...
1259c	5530	" (" ") " " " " " " " " Set Screw
197d	5556	" (" ") Screw ...
42054	5544	Needle Bar ...
42253	5544	" " Bushing ...
462c	5544	" " " Set Screw ...
42061	5544	" " Connecting Bracket with 187d and 223f ...
187d	5544	" " " " Clamping Screw ...
42055	5544	" " " Link ...
*42335	—	" " " " 42055 with 42061, 42104 and two 40247
40247	5544	" " " " Hinge Pin ...
223f	5544	" " " " " " " Set Screw for 42061 ...
904c	5544	" " " " " " " " " " 42104 ...
42057	5544	" " " " Rod with 42076, 432878 and four 896c ...
*42383	—	" " " " " 42057 with 42074 ...
*42371	—	" " " " " 42383 with 42023 ...
*42076	—	" " " " " Cap (lower) ...
896c	20795	" " " " " " (") Screw ...
*132878	—	" " " " " " (upper) ...
896c	20795	" " " " " " (") Screw ...
42077	2271	" " " " " Guide ...
171f	5544	" " " " " " " Screw ...
42103	5544	" " " Crank (back) with 1258c and two 1259c ...
42074	2271	" " " " (") Ball Stud ...
1259c	5530	" " " " (") " " " Set Screw ...
1259c	5530	" " " " (") Position Screw ...
1258c	5544	" " " " (") Set Screw ...
42104	5544	" " " " (front) with 904c, 1258c and 1259c ...
1259c	5530	" " " " (") Position Screw ...
1258c	5544	" " " " (") Set Screw ...
42105	5544	" " " " Shaft ...
42487	20795	" " " " " Bushing ...
624c	20800	" " " " " " Set Screw ...
42115	5544	" " " Thread Retainer Bracket ...
228d	5544	" " " " " " Screw ...
42483	20795	" " " " " Disc ...
93c	5544	" " " " " Screw ...
10107	5544	" " " " " Spring ...
1728c	5544	" Clamping Nut ...
42066	5544	" Guard ...
42195	5596	" " Holder ...
1101c	5543	" " " " Screw ...
171f	5544	" " " " Screw ...

No.	Plate	Name
42196	—	Presser Foot Body ...
9320	—	" " Hinge Pin ...
42197	—	" " Plate ...
11058	2276	" " Spring ...
42160	2273	" " " Adjusting Pin ...
464c	2276	" " " " " " Set Screw ...
42198	5540	Presser Foot (spring, hinged), complete, Nos. 464c, 9320, 11058, 42160, 42196 and 42197 ...
1324c	5591	Presser Foot Screw ...
39541	2272	" " " Washer ...
42069	5576	" Lever ...
42376	—	" " 42069 with 42045 ...
42045	5542	" " Hinge Stud ...
1120c	5591	" " " " Set Screw ...
42070	2272	" " Litter ...
85d	2277	" " " Hinge Screw ...
1377c	2277	" " Screw Stud (eccentric) ...
1547j	5543	" " " " Nut ...
42071	2272	" " Spring ...
1378d	2277	Pressure Regulating Thumb Screw ...
132631	2276	Spreader ...
197d	5556	" Screw ...
2102	5556	Tension (looper, left hand) Disc ...
1560c	5556	" (" " ") Regulating Thumb Nut ...
828c	5556	" (" " ") Screw Stud ...
12418	—	" (" " ") " " 828c with 1560c ...
42121	5556	" (" " ") Spring ...
2102	5556	" (looper, right hand) Disc ...
1560c	5556	" (" " ") Regulating Thumb Nut ...
828c	5556	" (" " ") Screw Stud ...
42418	—	" (" " ") " " 828c with 1560c ...
10148	5556	" (" " ") Spring ...
17547	5556	" (" " ") Thread Guide ...
2102	5556	" (needle thread) Disc ...
1560c	5556	" (" " ") Regulating Thumb Nut ...
916c	5556	" (" " ") Screw Stud ...
44209	—	" (" " ") " " 916c with 1560c ...
10148	5556	" (" " ") Spring ...
42082	5556	" (" " ") Thread Guide ...
42242	7388	Thread (looper, left hand) Eyelet ...
233d	5530	" (" " ") " Screw ...
42084	5556	" (" " ") Tube ...

No.	Plate	Name					
462c	5529	Thread (looper, left hand) Tube Set Screw
42093	5556	" (looper, right hand) Staple
190d	5556	" (" " ") " Screw
42127	5556	" (" " ") Take-up
197d	5556	" (" " ") " Screw
42096	5556	" (needle) Eyelet
217j	5556	" (") " Screw
42128	2274	" (") Take-up
197d	5556	" (") " Screw
42199	5540	Throat Plate
742f	2277	" " Screw
*15404	—	Trade Mark
15405	—	" " Rivet

PARTS COMPLETE

FOR

No. 81K9 MACHINE

FOR SEAMING AND INSERTING SLEEVES AND HEMMING THE
 BOTTOMS AND CUFFS OF LIGHT AND MEDIUM SWEATERS,
 HAS TRIMMER AND AUXILIARY FEED TO PREVENT FULLING
 OR "BELLING" THE EDGE WHILE STITCHING.
 HIGH LIFT. FOOT LIFTER.

No.	Plate	Name					
*12185	—	Arm with 15404, two each 462c, 621c, 15405, 42253 and 42187
4389	5543	" Dowel Pin
949e	2277	" Screw
12001	5576	Balance Wheel, 2 $\frac{3}{16}$ " pulley, with 424c and 1354c
1354c	2277	" " Position Screw
424c	2277	" " Set Screw
42002	5526	Cloth Plate
42401	—	Cloth Plate, complete, Nos. 42002, 42005, 42108, 42294, two 236c and five 229e
42294	5598	Cloth Plate Extension (lower)
229e	2277	" " " (") Screw
42108	5526	" " " (upper)
229e	2277	" " " (") Screw
1437d	2277	" " Hinge Screw
1655e	2277	" " " " Nut
42005	5526	" " Lock Spring
236c	2277	" " " " Screw
42147	5557	Feed (back) Bar
61c	5590	" (") " Hinge Screw
42148	5557	" (") Connecting Link
1132e	5557	" (") " Hinge Screw
42149	5533	" (") Dog (3 teeth, 16 teeth to the inch)
203d	5591	" (") " Screw
42150	5557	" (") Regulator
1132e	5557	" (") " Hinge Screw
190d	5556	" (") " Set Screw
1444c	5557	" (") " Thumb Screw

No.	Plate	Name
42151	5590	Feed (front) Bar with 1253e
42007	5529	" (") " Hinge Pin
1253c	5529	" (") " " " " Set Screw
42008	5529	" (") Connecting Rod with 42009 and two 1057e
*42371	---	" (") " " " 42008 with 1373c and 1520c
*42009	---	" (") " " " Cap
1057c	5529	" (") " " " " Screw
1373c	5529	" (") " " " " Hinge Screw
1520c	5529	" (") " " " " " Nut
42102	7397	" (") Dog (17 teeth, 16 teeth to the inch)
190d	5526	" (") " " " " " Screw
42011	5529	" (") Eccentric with two 453c
42298	2265	" (") " " " " " Cover
207d	5529	" (") " " " " " " Screw
453c	5529	" (") " " " " " " Set Screw
42208	5596	" (") Lifting Eccentric with two 462c
42013	5529	" (") " " " " " " Connection
462c	5529	" (") " " " " " " Set Screw
1374c	5530	" (") Regulating Screw Stud
1680c	5530	" (") " " " " " " Nut
42290	5530	" (") " " " " " " Washer
42014	5530	" (") Regulator with 233j and two 1259c
42015	5529	" (") " " " " " " Connection with 1012c
*42368	---	" (") " " " " " 42015 with 1373c and 1520c
1012c	5529	" (") " " " " " " Adjusting Screw
1373c	5529	" (") " " " " " " Hinge Screw
1520c	5529	" (") " " " " " " " " Nut
42016	5530	" (") " " " " " " Hinge Stud
42017	5529	" (") " " " " " " Indicator
42018	5530	" (") " " " " " " Plate
337d	5530	" (") " " " " " " " " Screw
207d	5529	" (") " " " " " " " " Screw
1259c	5530	" (") " " " " " " " " Set Screw
233j	5530	" (") " " " " " " " " Stop Screw
42154	5557	" (") Rock Shaft
42155	---	Feed (front) Rock Shaft, complete, Nos. 42021 and 42154
42021	5530	Feed (front) Rock Shaft Crank with 157e
157e	5530	" (") " " " " " " Clamping Screw
42098	5530	" (") " " " " " " Hinge Pin
42079	5530	" (") " " " " " " " " Bushing
1036c	5530	" (") " " " " " " " " " " Set Screw
*42209	---	Frame
42266	2263	" Rotary Shaft
42024	5576	" " " " Bushing (front)
1036c	5530	" " " " " (") Set Screw

No.	Plate	Name
42211	5596	Frame Rotary Shaft Crank with 1036c and 1375c
1375c	2277	" " " " " " " " Position Screw
1036c	5530	" " " " " " " " Set Screw
42026	5576	" " " " " Flanged Bushing (back) with 51967
51967	7403	" " " " " " " (") Oil Pad (braided cotton)
1036c	5530	" " " " " " " " " (") Set Screw
42367	5591	" " " " " " " " Front Bearing Oil Pad (braided cotton)
132560	2265	" Side Cover (left) with 132701
132701	2268	" " " " (") Handle
330w	2277	" " " " (") Screw
42028	5526	" " " " (right, hinged)
42101	5513	" " " " (") Lock Spring
330w	2277	" " " " (") Screw
42029	5576	" Top Cover
42212	5596	" " " " Extension
42102	5543	" " " " " " Holder
*42319	---	Frame Top Cover Extension Holder 42102, with 42101, 42212, 42298, two each 176j and 207d
283w	5543	Frame Top Cover Extension Holder Thumb Screw
19014	5539	" " " " " " " " " " Washer
176d	5543	" " " " " " " " " " Screw
742f	2277	" " " " " " " " " " Screw
42213	5560	Knife (movable)
<i>NOTE. - Two No. 42213 are sent with this machine.</i>		
42214	5560	Knife (movable) Gib
42035	5542	" (") Holder
42215	---	" (") " " 42035, with 133f, 42040, 42214, 42216 and two 401d
42216	5560	" (") " " " " Cap
401d	5542	" (") " " " " " " Screw
42038	5542	" (") " " " " " " Guide with 336f
42039	5542	" (") " " " " " " Plate
621d	5542	" (") " " " " " " " " Screw
336f	5542	" (") " " " " " " " " Set Screw
1331	5542	" (") " " " " " " " " Screw
42040	5542	" (") " " " " " " " " Extension Pin
42041	5542	" (") " " " " " " " " Spring
42042	5542	" (") " " " " " " " " Lever
42217	5560	" (") " " " " " " " " Connection with 42218 and two 175e
*42370	---	" (") " " " " " " " " 42217 with 1373c and 1520c
*42218	---	" (") " " " " " " " " Cap
175e	5542	" (") " " " " " " " " " " Screw
1373c	5542	" (") " " " " " " " " " " Hinge Screw
1520c	5542	" (") " " " " " " " " " " " " Nut

No.	Plate	Name
42045	5542	Knife (movable) Lever Hinge Stud
1229c	5542	" (") " " " " Set Screw
42046	5543	" (stationary) with 42049
<i>NOTE.—Two No. 42046 are sent with this machine.</i>		
42048	5543	Knife (stationary) Clamping Stud
1534d	5543	" (") " " " Thumb Nut
132766	2267	" (") Holder
1376c	5543	" (") " " Regulating Thumb Screw
1101c	5543	" (") " " Screw
440f	5543	" (") " " Stop Screw
1547j	5543	" (") " " " Nut
42049	5543	" (") Stud
42219	5560	Looper (left hand)
132870	2273	" (" ") Lever with 50117c
*42318	—	" (" ") " " 132870 with 42053
42052	2271	" (" ") " " Connecting Link
*42384	—	" (" ") " " " 42052 with two each 1520c and 50562c
50562c	20795	" (" ") " " " Hinge Screw
1520c	5529	" (" ") " " " " " Nut
42053	2272	" (" ") " " Hinge Stud
1036c	5530	" (" ") " " " Set Screw
50117c	2276	" (" ") Set Screw
42220	5560	" (right hand)
42073	2271	" (" ") and Spreader Lever with 1259c
*42330	—	" (" ") " " " 42073 with 233d, 42078 and 42242
42221	5560	" (" ") " " " Ball Stud
1259c	5530	" (" ") " " " " " Set Screw
42075	2271	" (" ") " " " Connection with 42059, 42076 and four 896c
*42076	—	" (" ") " " " Connection Cap (lower)
896c	20795	" (" ") " " " " " (") Screw
*42059	—	" (" ") " " " " Cap (upper)
896c	20795	" (" ") " " " " " (") Screw
42077	2271	" (" ") " " " " Guide
171f	5544	" (" ") " " " " " Screw
42403	2273	" (" ") " " " " Oil Tube and Bracket with 29599
29599	2272	" (" ") " " " " Connection Oil Tube Packing (left)

No.	Plate	Name
42078	2271	Looper (right hand) and Spreader Lever Hinge Pin
42079	5530	" (" ") " " " " " Bushing
1259c	5530	" (" ") " " " " " " Set Screw
197d	5556	" (" ") Screw
38534	5560	Needle Bar (hollow)
42253	5544	" " Bushing
462c	5544	" " " " Set Screw
42291	5596	" " Connecting Bracket with 223f and 1057c
1057c	5529	" " " " Clamping Screw
42055	5544	" " " " Link
*42326	—	" " " " 42055 with 42101, 42291 and two 40247
40247	5544	" " " " " Hinge Pin
223f	5544	" " " " " " " Set Screw for 42291
904c	5544	" " " " " " " " " 42104
42057	5544	" " " " Rod with 42076, 132878 and four 896c
*42383	—	" " " " " 42057 with 42074
*42373	—	" " " " " 42383 with 42266
*42076	—	" " " " " Cap (lower)
896c	20795	" " " " " " (") Screw
*132878	—	" " " " " " " (upper)
896c	20795	" " " " " " " (") Screw
42077	2271	" " " " " " Guide
171f	5544	" " " " " " " Screw
42103	5544	" " Crank (back) with 1258c and two 1259c
42074	2271	" " " " (") Ball Stud
1259c	5530	" " " " (") " " Set Screw
1259c	5530	" " " " (") Position Screw
1258c	5544	" " " " (") Set Screw
42104	5544	" " " " (front) with 904c, 1258c and 1259c
1259c	5530	" " " " (") Position Screw
1258c	5544	" " " " (") Set Screw
42105	5544	" " " " Shaft
42487	20795	" " " " " Bushing
624c	20800	" " " " " " Set Screw
42115	5544	" " Thread Retainer Bracket
228d	5544	" " " " " " " Screw
42483	20795	" " " " " Disc
93c	5544	" " " " " " Screw
10107	5544	" " " " " Spring
1237C 4228c	5544 20795	" " " " " Clamping Nut
42066	5544	" " Guard
171f	5544	" " " " " Screw

No. 81K9 MACHINE PARTS

No.	Plate	Name
42157	--	Presser Foot Body
42404	7397	" " Chaining-off Finger for 42406
42500	--	" " " " 132663
233d	5530	" " " " Screw
9320	--	" " Hinge Pin
42405	--	" " Plate
14058	2276	" " Spring
42160	2273	" " " Adjusting Pin
464c	2276	" " " " Set Screw
42406	7397	Presser Foot (spring hinged), complete, Nos. 233d, 461c, 9320, 14058, 42157, 42160, 42404 and 42405
132663	2269	Presser Foot (spring hinged), complete, Nos. 233d, 461c, 9320, 14058, 42157, 42160, 42405 and 42500
1324c	5591	Presser Foot Screw
39541	2272	" " " Washer
42227	2271	" Lever
42377	--	" " 42227 with 42015
42045	5542	" " Hinge Stud
1120c	5591	" " " " Set Screw
42070	2272	" " Lifter
85d	2277	" " " Hinge Screw
1377c	2277	" " Screw Stud (eccentric)
1547j	5543	" " " " Nut
42071	2272	" " Spring
1378d	2277	Pressure Regulating Thumb Screw
42250	5560	Spreader
197d	5556	" Screw
2102	5556	Tension (looper, left hand) Disc
1560c	5556	" (" " ") Regulating Thumb Nut
828c	5556	" (" " ") Screw Stud
42418	--	" (" " ") " " 828c with 1560c
42121	5556	" (" " ") Spring
2102	5556	" (looper, right hand) Disc
1560c	5556	" (" " ") Regulating Thumb Nut
828c	5556	" (" " ") Screw Stud
42418	--	" (" " ") " " 828c with 1560c
10148	5556	" (" " ") Spring
17547	5556	" (" " ") Thread Guide
2102	5556	" (needle thread) Disc
1560c	5556	" (" " ") Regulating Thumb Nut
916c	5556	" (" " ") Screw Stud
44209	--	" (" " ") " " 916c with 1560c
2103	5556	" (" " ") Spring

No. 81K9 MACHINE PARTS

No.	Plate	Name
42082	5556	Tension (needle thread) Thread Guide
42242	7388	Thread (looper, left hand) Eyelet
233d	5530	" (" " ") " Screw
42122	7388	" (" " ") Nipper Spring (lower)
42123	7388	" (" " ") " " (upper)
176d	5543	" (" " ") " " Screw
42124	5590	" (" " ") Pull-off
42125	5590	" (" " ") " Eyelet
233d	5530	" (" " ") " " Screw
42084	5556	" (" " ") Tube
462c	5529	" (" " ") " Set Screw
42126	2266	" (looper, right hand) Pull-off
42093	5556	" (" " ") Staple
190d	5556	" (" " ") " Screw
42127	5556	" (" " ") Take-up
197d	5556	" (" " ") " " Screw
42096	5556	" (needle) Eyelet
217j	5556	" (") " " Screw
42128	2274	" (") Take-up
197d	5556	" (") " " Screw
42407	7397	Throat Plate
742f	2277	" " " Screw
*15404	--	Trade Mark
15405	--	" " Rivet

PARTS COMPLETE
FOR
No. 81K20 MACHINE

FOR TRIMMING, OVEREDGING AND CLOSING SEAMS IN FINE STOCKINGS AND UNDERWEAR MADE OF SILK, LISLE THREAD, ETC. HAS AUXILIARY FEED TO PREVENT FULLING THE EDGES WHILE STITCHING. BIGHT ADJUSTABLE FROM $\frac{1}{8}$ " TO $\frac{3}{8}$ ". TWO-THREAD STITCH. FOOT LIFTER.

No.	Plate	Name
*42484	—	Arm with 15404, two each 462c, 624c, 15405, 42253 and 42487 ...
4389	5543	" Dowel Pin ...
949c	2277	" Screw ...
42001	5576	Balance Wheel, 2 $\frac{3}{8}$ " pulley, with 424c and 1354c ...
1354c	2277	" " Position Screw ...
424c	2277	" " Set Screw ...
*42145	—	Cloth Plate ...
42146	—	Cloth Plate, complete, Nos. 42003, 42005, 42108, 42115, two 236c and five 229e ...
42003	5526	Cloth Plate Extension (lower) ...
229e	2277	" " " (") Screw ...
42108	5526	" " " (upper) ...
229e	2277	" " " (") Screw ...
1437d	2277	" " Hinge Screw ...
1655e	2277	" " " " Nut ...
42005	5526	" " Lock Spring ...
236c	2277	" " " " Screw ...
42147	5557	Feed (back) Bar ...
61c	5590	" (") " Hinge Screw ...
42148	5557	" (") Connecting Link ...
1132c	5557	" (") " " Hinge Screw ...
42421	7399	" (") Dog, fine teeth, for silk work (5 teeth, 36 teeth to the inch) ...
203d	5591	" (") " Screw ...
42150	5557	" (") Regulator ...
1132c	5557	" (") " Hinge Screw ...
190d	5556	" (") " Set Screw ...
1444c	5557	" (") " Thumb Screw ...

No.	Plate	Name
42151	5590	Feed (front) Bar with 1253c ...
42007	5529	" (") " Hinge Pin ...
1253c	5529	" (") " " Set Screw ...
42008	5529	" (") Connecting Rod with 42009 and two 1057c ...
*42371	—	" (") " " 42008 with 1373c and 1520c ...
*42009	—	" (") " " Cap ...
1057c	5529	" (") " " Screw ...
1373c	5529	" (") " " Hinge Screw ...
1520c	5529	" (") " " Nut ...
42422	7399	" (") Dog, fine teeth, for silk work (29 teeth, 22 teeth to the inch) ...
190d	5526	" (") " Screw ...
42011	5529	" (") Eccentric with two 453c ...
42153	2265	" (") " Cover ...
207d	5529	" (") " " Screw ...
453c	5529	" (") " Set Screw ...
42012	5529	" (") Lifting Eccentric with two 462c ...
42013	5529	" (") " " Connection ...
462c	5529	" (") " " Set Screw ...
1374c	5530	" (") Regulating Screw Stud ...
1680c	5530	" (") " " Nut ...
42290	5530	" (") " " Washer ...
42014	5530	" (") Regulator with 233j and two 1259c ...
42015	5529	" (") " Connection with 1012e ...
*42368	—	" (") " " 42015 with 1373c and 1520c ...
1012e	5529	" (") " " Adjusting Screw ...
1373c	5529	" (") " " Hinge Screw ...
1520c	5529	" (") " " Nut ...
42016	5530	" (") " Hinge Stud ...
42017	5529	" (") " Indicator ...
42018	5530	" (") " " Plate ...
337d	5530	" (") " " Screw ...
207d	5529	" (") " " Screw ...
1259c	5530	" (") " Set Screw ...
233j	5530	" (") " Stop Screw ...
42154	5557	" (") Rock Shaft ...
42155	—	Feed (front) Rock Shaft, complete, Nos. 42021 and 42154 ...
42021	5530	Feed (front) Rock Shaft Crank with 157e ...
157e	5530	" (") " " Clamping Screw ...
42098	5530	" (") " " Hinge Pin ...
42079	5530	" (") " " Bushing ...
1036c	5530	" (") " " Set Screw ...
*42022	—	Frame ...
42023	5576	" Rotary Shaft ...
42024	5576	" " " Bushing (front) ...

No.	Plate	Name
1036c	5530	Frame Rotary Shaft Bushing (front) Set Screw
42110	2272	" " " Crank with 1036c and 1375c
1375c	2277	" " " " Position Screw
1036c	5530	" " " " Set Screw
42026	5576	" " " Flanged Bushing (back) with 54967
54967	7403	" " " " " (") Oil Pad (braided cotton)
1036c	5530	" " " " " (") Set Screw
42367	5591	" " " Front Bearing Oil Pad (braided cotton)
132560	2265	" Side Cover (left) with 132701
132701	2268	" " " (") Handle
330w	2277	" " " (") Screw
42028	5526	" " " (right, hinged)
42101	5543	" " " (") Lock Spring
330w	2277	" " " (") Screw
42029	5576	" Top Cover
132650	2268	" " " Extension
42102	5543	" " " Holder
*42324	—	" " " " " 42102 with 42101, 42153, 132650, two each 176d and 207d
283w	5543	" " " " Holder Thumb Screw
19044	5539	" " " " " " " Washer
176d	5543	" " " " Screw
742f	2277	" " " " Screw
42111	5542	Knife (movable)
<i>NOTE.—Two No. 42111 are sent with this machine.</i>		
42112	5542	Knife (movable) Gib
42035	5542	" (") Holder
42113	—	" (") " 42035 with 133f, 42037, 42040, 42112 and two 404d
42037	5542	" (") " Cap
404d	5542	" (") " " Screw
42038	5542	" (") " Guide with 336f
42039	5542	" (") " " Plate
621d	5542	" (") " " " Screw
336f	5542	" (") " " Set Screw
133f	5542	" (") " " Screw
42040	5542	" (") " " Extension Pin
42041	5542	" (") " " Spring
42042	5542	" (") " Lever
42043	5542	" (") " " Connection with 42044 and two 175c
*42369	—	" (") " " 42043 with 1373c and 1520c
*42044	—	" (") " " Cap
175c	5542	" (") " " " Screw
1373c	5542	" (") " " " Hinge Screw
1520c	5542	" (") " " " " Nut

No.	Plate	Name
42045	5542	Knife (movable) Lever Hinge Stud
1229c	5542	" (") " " " " Set Screw
42046	5543	" (stationary) with 42049
<i>NOTE.—Two No. 42046 are sent with this machine.</i>		
42048	5543	Knife (stationary) Clamping Stud
1534d	5543	" (") " " " Thumb Nut
132766	2267	" (") Holder
1376c	5543	" (") " " Regulating Thumb Screw
1101c	5543	" (") " " Screw
110f	5543	" (") " " Stop Screw
1547j	5543	" (") " " " " Nut
12049	5543	" (") Stud
42050	2272	Looper (left hand)
132870	2273	" (" ") Lever with 50117c
*42318	—	" (" ") " 132870 with 42053
42052	2271	" (" ") " " Connecting Link
50562c	20795	" (" ") " " " Hinge Screw
1520c	5529	" (" ") " " " " " Nut
*42384	—	" (" ") " " " " 42052 with two each 1520c and 50562c
42053	2272	" (" ") " " Hinge Stud
1036c	5530	" (" ") " " " " Set Screw
50117c	2276	" (" ") Set Screw
42166	2272	" (right hand)
42073	2271	" (" ") and Spreader Lever with 4259c
*42330	—	" (" ") " " " " 42073 with 233d, 42078 and 42242
42074	2271	" (" ") " " " " Ball Stud
1259c	5530	" (" ") " " " " " Set Screw
42075	2271	" (" ") " " " " Connection with 42059, 42076 and four 896c
42416	—	" (" ") " " " " Connection 42075 with 42074
42379	—	" (" ") " " " " " 42416 with 42110
*42076	—	" (" ") " " " " " Cap (lower)
896c	20795	" (" ") " " " " " " (") Screw
*42059	—	" (" ") " " " " " " Cap (upper)
896c	20795	" (" ") " " " " " " " (") Screw
42077	2271	" (" ") " " " " " Guide
171f	5544	" (" ") " " " " " " Screw

No.	Plate	Name
42403	2273	Looper (right hand) and Spreader Lever Connection Oil Tube and Bracket with 29599
29509	2272	" (" ") " " " Connection Oil Tube Packing (felt)
42078	2271	" (" ") " " " Hinge Pin
42079	5530	" (" ") " " " " " Bushing
1259c	5530	" (" ") " " " " " " " Set Screw
197d	5556	" (" ") Screw
42054	5544	Needle Bar
42253	5544	" " Bushing
462c	5544	" " " Set Screw
42061	5544	" " Connecting Bracket with 187d and 223f
187d	5544	" " " " Clamping Screw
42055	5544	" " " " Link
*42335	—	" " " " 42055 with 42061, 42104 and two 40247
40247	5544	" " " " Hinge Pin
223f	5544	" " " " " " Set Screw for 42061
904c	5544	" " " " " " " " " for 42104
42057	5544	" " " " Rod with 42076, 42878 and four 896c
*42383	—	" " " " " 42057 with 42074
*42374	—	" " " " " 42383 with 42023
*42076	—	" " " " " Cap (lower)
896c	20795	" " " " " " (") Screw
*132878	—	" " " " " " (upper)
896c	20795	" " " " " " (") Screw
42077	2271	" " " " " Guide
171f	5544	" " " " " " Screw
42103	5544	" " Crank (back) with 1258c and two 1259c
42074	2271	" " " (") Ball Stud
1259c	5530	" " " (") " " Set Screw
1259c	5530	" " " (") Position Screw
1258c	5544	" " " (") Set Screw
42104	5544	" " " (front) with 904c, 1258c and 1259c
1259c	5530	" " " (") Position Screw
1258c	5544	" " " (") Set Screw
42105	5544	" " " " Shaft
42487	20795	" " " " Bushing
624c	20800	" " " " " Set Screw
42115	5544	" " Thread Retainer Bracket
228d	5544	" " " " " Screw
42483	20795	" " " " Disc
93c	5544	" " " " " Screw
10107	5544	" " " " " Spring

No.	Plate	Name
1728c	5544	Needle Clamping Nut
42066	5544	" Guard
171f	5544	" " Screw
42288	5599	Presser Foot Chaining-off Finger
233d	5530	" " " " " Screw
42405	—	" " Plate (back)
9320	—	" " " (") Hinge Pin
14058	2276	" " " (") Spring
42160	2273	" " " (") " Adjusting Pin
464c	2276	" " " (") " " " Set Screw
42263	—	" " " (front)
42461	7397	" " " (") Hinge Pin
42264	—	" " Shank
42420	7397	Presser Foot (spring hinged), complete, Nos. 233d, 464c, 9320, 14058, 42160, 42263, 42264, 42288, 42405 and 42461
1324c	5591	Presser Foot Screw
39541	2272	" " " Washer
42069	5576	" Lever
42376	—	" " 42069 with 42045
42045	5542	" " Hinge Stud
4420c	5591	" " " " Set Screw
42070	2272	" " Lifter
85d	2277	" " " Hinge Screw
4377c	2277	" " Screw Stud (eccentric)
1547j	5543	" " " " Nut
42071	2272	" " Spring
1378d	2277	Pressure Regulating Thumb Screw
132631	2276	Spreader
197d	5556	" Screw
2102	5556	Tension (looper, left hand) Disc
4560c	5556	" (" " ") Regulating Thumb Nut
828c	5556	" (" " ") Screw Stud
42418	—	" (" " ") " " 828c with 4560c
42121	5556	" (" " ") Spring
2102	5556	" (looper, right hand) Disc
4560c	5556	" (" " ") Regulating Thumb Nut
828c	5556	" (" " ") Screw Stud
42418	—	" (" " ") " " 828c with 4560c
10148	5556	" (" " ") Spring
17547	5556	" (" " ") Thread Guide
2102	5556	" (needle thread) Disc

No. 81K20 MACHINE PARTS

No.	Plate	Name
1560c	5556	Tension (needle thread) Regulating Thumb Nut ...
916c	5556	" (" ") Screw Stud ...
41209	-	" (" ") " " 916c with 1560c ...
10148	5556	" (" ") Spring ...
42082	5556	" (" ") Thread Guide ...
42242	7388	Thread (looper, left hand) Eyelet ...
233d	5530	" (" " ") " Screw ...
42084	5556	" (" " ") Tube ...
462c	5529	" (" " ") " Set Screw ...
42126	2266	" (looper, right hand) Pull-off ...
42093	5556	" (" " ") Staple ...
190d	5556	" (" " ") " Screw ...
42127	5556	" (" " ") Take-up ...
197d	5556	" (" " ") " Screw ...
42096	5556	" (needle) Eyelet ...
217j	5556	" (") " Screw ...
42128	2274	" (") Take-up ...
197d	5556	" (") " Screw ...
42415	7399	Throat Plate ...
742f	2277	" " Screw ...
*15404	—	Trade Mark ...
15405	—	" " Rivet ...

PARTS COMPLETE

FOR

No. 81K21 MACHINE

FOR TRIMMING, OVEREDGING AND BLIND STITCH HEMMING OR WELTING ON UNDERWEAR MADE OF SILK, LISLE THREAD, ETC. HAS AUXILIARY FEED TO PREVENT FULLING THE EDGES WHILE STITCHING. BIGHT $\frac{1}{16}$ ". TWO-THREAD STITCH. FOOT LIFTER.

No.	Plate	Name
*42481	—	Arm with 15404, two each 462c, 621c, 15405, 42253 and 42487 ...
4389	5543	" Dowel Pin ...
949e	2277	" Screw ...
42001	5576	Balance Wheel, 2 $\frac{3}{16}$ " pulley, with 424c and 1354c ...
1354c	2277	" " Position Screw ...
424c	2277	" " Set Screw ...
*42145	—	Cloth Plate ...
42146	—	Cloth Plate, complete, Nos. 42003, 42005, 42108, 42145, two 236c and five 229e ...
42003	5526	Cloth Plate Extension (lower) ...
229e	2277	" " " (") Screw ...
42108	5526	" " " (upper) ...
229e	2277	" " " (") Screw ...
1437d	2277	" " Hinge Screw ...
1655e	2277	" " " " Nut ...
42005	5526	" " Lock Spring ...
236c	2277	" " " " Screw ...
42147	5557	Feed (back) Bar ...
61c	5590	" (") " Hinge Screw ...
42148	5557	" (") Connecting Link ...
1132c	5557	" (") " " Hinge Screw ...
42421	7399	" (") Dog, fine teeth, for silk work (5 teeth, 36 teeth to the inch) ...
203d	5591	" (") " Screw ...
42150	5557	" (") Regulator ...
1132c	5557	" (") " Hinge Screw ...
190d	5556	" (") " Set Screw ...
1441c	5557	" (") " Thumb Screw ...

No.	Plate	Name
1560c	5556	Tension (needle thread) Regulating Thumb Nut
916c	5556	" (" ") Screw Stud
44209	—	" (" ") " " 916c with 1560c
10148	5556	" (" ") Spring
42082	5556	" (" ") Thread Guide
42242	7388	Thread (looper, left hand) Eyelet
233d	5530	" (" " ") " Screw
42084	5556	" (" " ") Tube
462c	5529	" (" " ") " Set Screw
42126	2266	" (looper, right hand) Pull-off
42093	5556	" (" " ") Staple
190d	5556	" (" " ") " Screw
42127	5556	" (" " ") Take-up
197d	5556	" (" " ") " Screw
42096	5556	" (needle) Eyelet
217j	5556	" (") " Screw
42128	2274	" (") Take-up
197d	5556	" (") " Screw
42415	7399	Throat Plate
742f	2277	" " Screw
*15404	—	Trade Mark
15405	—	" " Rivet

PARTS COMPLETE

FOR

No. 81K21 MACHINE

FOR TRIMMING, OVEREDGING AND BLIND STITCH HEMMING OR WELTING ON UNDERWEAR MADE OF SILK, LISLE THREAD, ETC. HAS AUXILIARY FEED TO PREVENT FULLING THE EDGES WHILE STITCHING. BIGHT $\frac{1}{16}$ ". TWO-THREAD STITCH. FOOT LIFTER.

No.	Plate	Name
*42484	—	Arm with 15404, two each 462c, 624c, 15405, 42253 and 42487
4389	5543	" Dowel Pin
949e	2277	" Screw
42001	5576	Balance Wheel, 2 $\frac{1}{16}$ " pulley, with 424c and 1354c
1354c	2277	" " Position Screw
424c	2277	" " Set Screw
*42145	—	Cloth Plate
42146	—	Cloth Plate, complete, Nos. 42003, 42005, 42108, 42145, two 236c and five 229e
42003	5526	Cloth Plate Extension (lower)
229e	2277	" " " (") Screw
42108	5526	" " " (upper)
229e	2277	" " " (") Screw
1437d	2277	" " Hinge Screw
1655e	2277	" " " " Nut
42005	5526	" " Lock Spring
236c	2277	" " " " Screw
42147	5557	Feed (back) Bar
61c	5590	" (") " Hinge Screw
42148	5557	" (") Connecting Link
1132c	5557	" (") " " Hinge Screw
42421	7399	" (") Dog, fine teeth, for silk work (5 teeth, 36 teeth to the inch)
203d	5591	" (") " Screw
42150	5557	" (") Regulator
1132c	5557	" (") " Hinge Screw
190d	5556	" (") " Set Screw
1444c	5557	" (") " Thumb Screw

No.	Plate	Name
42151	5590	Feed (front) Bar with 1253c
42007	5529	" (") " Hinge Pin
1253c	5529	" (") " " " Set Screw
42008	5529	" (") Connecting Rod with 42009 and two 1057c
*42371	---	" (") " " 42008 with 1373c and 1520c
*42009	---	" (") " " Cap
1057c	5529	" (") " " " Screw
1373c	5529	" (") " " " Hinge Screw
1520c	5529	" (") " " " " Nut
42422	7399	" (") Dog, fine teeth, for silk work (29 teeth, 22 teeth to the inch)
190d	5526	" (") " Screw
42011	5529	" (") Eccentric with two 453c
42153	2265	" (") " Cover
207d	5529	" (") " " Screw
453c	5529	" (") " " Set Screw
42012	5529	" (") Lifting Eccentric with two 462c
42013	5529	" (") " " Connection
462c	5529	" (") " " " Set Screw
1374c	5530	" (") Regulating Screw Stud
1680c	5530	" (") " " " " Nut
42290	5530	" (") " " " " Washer
42014	5530	" (") Regulator with 233j and two 1259c
42015	5529	" (") " " Connection with 1012c
*42368	---	" (") " " 42015 with 1373c and 1520c
1012c	5529	" (") " " " Adjusting Screw
1373c	5529	" (") " " " " Hinge Screw
1520c	5529	" (") " " " " " Nut
42016	5530	" (") " " " Hinge Stud
42017	5529	" (") " " " Indicator
42018	5530	" (") " " " Plate
337d	5530	" (") " " " " Screw
207d	5529	" (") " " " " Screw
1259c	5530	" (") " " " " Set Screw
233j	5530	" (") " " " " Stop Screw
42154	5557	" (") Rock Shaft
42155	---	Feed (front) Rock Shaft, complete, Nos. 42021 and 42154
42021	5530	Feed (front) Rock Shaft Crank with 157c
157c	5530	" (") " " " " Clamping Screw
42098	5530	" (") " " " " Hinge Pin
42079	5530	" (") " " " " " Bushing
1036c	5530	" (") " " " " " " Set Screw
*42022	---	Frame
42023	5576	" Rotary Shaft
42024	5576	" " " Bushing (front)

No.	Plate	Name
1036c	5530	Frame Rotary Shaft Bushing (front) Set Screw
42025	2272	" " " Crank with 1259c and 1375c
1375c	2277	" " " " " Position Screw
1259c	5530	" " " " " " Set Screw
42026	5576	" " " " " Flanged Bushing (back) with 54967
54967	7403	" " " " " " (") Oil Pad (braided cotton)
1036c	5530	" " " " " " (") Set Screw
42367	5591	" " " " " Front Bearing Oil Pad (braided cotton)
132560	2265	" Side Cover (left) with 132701
132701	2268	" " " " (") Handle
330w	2277	" " " " (") Screw
42028	5526	" " " " (right, hinged)
42101	5543	" " " " (") Lock Spring
330w	2277	" " " " (") Screw
12029	5576	" Top Cover
132650	2268	" " " " Extension
42102	5543	" " " " " Holder
*42324	-	" " " " " " 42102 with 42101, 42153, 132650, two each 176d and 207d
283w	5543	" " " " " " Holder Thumb Screw
19044	5539	" " " " " " " " Washer
176d	5543	" " " " " " " Screw
742f	2277	" " " " " " Screw
42111	5542	Knife (movable)
<i>NOTE:—Two No. 42111 are sent with this machine.</i>		
42112	5542	Knife (movable) Gib
42035	5542	" (") Holder
42113	-	" (") " 42035 with 133f, 42037, 42040, 42112 and two 404d
42037	5542	" (") " " Cap
404d	5542	" (") " " " Screw
42038	5542	" (") " " Guide with 336f
42039	5542	" (") " " " Plate
621d	5542	" (") " " " " Screw
336f	5542	" (") " " " " Set Screw
133f	5542	" (") " " " " Screw
42040	5542	" (") " " " Extension Pin
42041	5542	" (") " " " Spring
42042	5542	" (") " " " Lever
42043	5542	" (") " " " Connection with 42044 and two 175c
*42369	-	" (") " " " 42043 with 1373c and 1520c
*42044	-	" (") " " " " Cap
175c	5542	" (") " " " " Screw
1373c	5542	" (") " " " " Hinge Screw

No.	Plate	Name
1520c	5542	Knife (movable) Lever Connection Hinge Screw Nut ...
42045	5542	" (") " Hinge Stud ...
1229c	5542	" (") " " " Set Screw ...
42046	5543	" (stationary) with 42049 ...
<i>NOTE.—Two No. 42046 are sent with this machine.</i>		
42048	5543	Knife (stationary) Clamping Stud ...
1534d	5543	" (") " " Thumb Nut ...
132766	2267	" (") Holder ...
1376c	5543	" (") " Regulating Thumb Screw ...
1101c	5543	" (") " Screw ...
440f	5543	" (") " Stop Screw ...
1547j	5543	" (") " " " Nut ...
42049	5543	" (") Stud ...
42050	2272	Looper (left hand) ...
132870	2273	" (" ") Lever with 50117c ...
*42318	—	" (" ") " 132870 with 42053 ...
42052	2271	" (" ") " Connecting Link ...
*42384	—	" (" ") " " 42052 with two each 1520c and 50562c
50562c	20795	" (" ") " " " Hinge Screw ...
1520c	5529	" (" ") " " " " Nut ...
42053	2272	" (" ") " Hinge Stud ...
1036c	5530	" (" ") " " " Set Screw ...
50117c	2276	" (" ") Set Screw ...
42166	2272	" (right hand) ...
42073	2271	" (" ") and Spreader Lever with 1259c ...
*42330	—	" (" ") " " " 42073 with 233d, 42078 and 42242
42074	2271	" (" ") " " " Ball Stud ...
1259c	5530	" (" ") " " " " Set Screw ...
42075	2271	" (" ") " " " Connection with 42059, 42076 and four 896c
42416	—	" (" ") " " " Connection 42075 with 42074
42382	—	" (" ") " " " " 42416 with 42025
42380	—	" (" ") " " " " 42382 with 171f and 42077
*42076	—	" (" ") " " " Connection Cap (lower)
896c	20795	" (" ") " " " " " (") Screw
*42059	—	" (" ") " " " " " (upper)
896c	20795	" (" ") " " " " " (") Screw
42077	2271	" (" ") " " " " Guide ...

No.	Plate	Name
171f	5544	Looper (right hand) and Spreader Lever Connection Guide Screw
42403	2273	" (" ") " " " " Oil Tube and Bracket with 29599
29599	2272	" (" ") " " " " Connection Oil Tube Packing (felt)
42078	2271	" (" ") " " " " Hinge Pin ...
42079	5530	" (" ") " " " " " Bushing ...
1259c	5530	" (" ") " " " " " " Set Screw
197d	5556	" (" ") Screw ...
42054	5544	Needle Bar ...
42253	5544	" " Bushing ...
462c	5544	" " " Set Screw ...
42061	5544	" " Connecting Bracket with 187d and 223f ...
187d	5544	" " " " Clamping Screw ...
42055	5544	" " " Link ...
*42335	—	" " " " 42055 with 42061, 42104 and two 40247
40247	5544	" " " " Hinge Pin ...
223f	5544	" " " " " " Set Screw for 42061 ...
904c	5544	" " " " " " " 42104 ...
42057	5544	" " " " Rod with 42076, 132878 and four 896c ...
*42383	—	" " " " " 42057 with 42074 ...
*42374	—	" " " " " 42383 with 42023 ...
*42076	—	" " " " " Cap (lower) ...
896c	20795	" " " " " (") Screw ...
*132878	—	" " " " " (upper) ...
896c	20795	" " " " " (") Screw ...
42077	2271	" " " " " Guide ...
171f	5544	" " " " " Screw ...
42103	5544	" " Crank (back) with 1258c and two 1259c ...
42074	2271	" " " (") Ball Stud ...
1259c	5530	" " " (") " " Set Screw ...
1259c	5530	" " " (") Position Screw ...
1258c	5544	" " " (") Set Screw ...
42104	5544	" " " (front) with 904c, 1258c and 1259c ...
1259c	5530	" " " (") Position Screw ...
1258c	5544	" " " (") Set Screw ...
42105	5544	" " " " Shaft ...
42487	20795	" " " " " Bushing ...
624c	20800	" " " " " Set Screw ...
42115	5544	" " Thread Retainer Bracket ...
228d	5544	" " " " " Screw ...
42483	20795	" " " " " Disc ...
93c	5544	" " " " " Screw ...

No.	Plate	Name
10107	5544	Needle Bar Thread Retainer Spring
737 1728c	5544	Clamping Nut
42066	5544	" Guard
1711	5544	" " Screw
42449	7402	Presser Foot Chaining-off Finger
233d	5530	" " " " Screw
42405	—	" " Plate (back)
9320	—	" " " (") Hinge Pin
14058	2276	" " " (") Spring
42160	2273	" " " (") " Adjusting Pin
464c	2276	" " " (") " " " Set Screw
42450	—	" " " (front)
42461	7397	" " " (") Hinge Pin
42264	—	" " Shank
42451	7402	Presser Foot (spring hinged), complete, Nos. 233d, 464c, 9320, 14058, 42160, 42264, 42405, 42449, 42450 and 42461
1324c	5591	Presser Foot Screw
39541	2272	" " " Washer
42069	5576	" Lever
42376	—	" " 42069 with 42045
42045	5542	" " Hinge Stud
1120c	5591	" " " " Set Screw
42070	2272	" " Lifter
85d	2277	" " " Hinge Screw
1377c	2277	" " Screw Stud (eccentric)
1547j	5543	" " " " Nut
42071	2272	" " Spring
1378d	2277	Pressure Regulating Thumb Screw
132631	2276	Spreader
197d	5556	" Screw
2102	5556	Tension (looper, left hand) Disc
1560c	5556	" (" " ") Regulating Thumb Nut
828c	5556	" (" " ") Screw Stud
42418	—	" (" " ") " " 828c with 1560c
42121	5556	" (" " ") Spring
2102	5556	" (looper, right hand) Disc
1560c	5556	" (" " ") Regulating Thumb Nut
828c	5556	" (" " ") Screw Stud
42418	—	" (" " ") " " 828c with 1560c
10148	5556	" (" " ") Spring
17547	5556	" (" " ") Thread Guide

No.	Plate	Name
2102	5556	Tension (needle thread) Disc
1560c	5556	" (" " ") Regulating Thumb Nut
916c	5556	" (" " ") Screw Stud
44209	—	" (" " ") " " 916c with 1560c
10148	5556	" (" " ") Spring
42082	5556	" (" " ") Thread Guide
42212	7388	Thread (looper, left hand) Eyelet
233d	5530	" (" " ") " Screw
42084	5556	" (" " ") Tube
462c	5529	" (" " ") " Set Screw
42093	5556	" (looper, right hand) Staple
190d	5556	" (" " ") " Screw
42127	5556	" (" " ") Take-up
197d	5556	" (" " ") " Screw
12096	5556	" (needle) Eyelet
217j	5556	" (") " Screw
42126	2266	" (") Pull-off
42128	2274	" (") Take-up
197d	5556	" (") " Screw
42468	7399	Throat Plate
742f	2277	" " Screw
*15404	—	Trade Mark
15405	—	" " Rivet
42488	2274	Welt Guide (solid)
42441	—	" " 42488 with 42440
42440	7400	" " Adjusting Slide
42442	7400	" " Holder
42443	—	" " " 42442 with 217b, 1117d, 1209c and 19044
42444	7400	" " " Extension with 42445
42445	7400	" " " " Stud
228b	5544	" " " " Screw
1209c	5539	" " " " Screw
19044	5539	" " " " Washer
1117d	5539	" " Regulating Thumb Screw
217b	5556	" " Screw
42446	—	Welt Guide, complete, adjustable from $\frac{1}{2}$ " to 1", Nos. 42441, 42443, 42444 and two 228b

PARTS COMPLETE
FOR
No. 81K10 MACHINE

FOR OVEREDGING CARPETS, RUGS, BLANKETS, ETC. NO TRIMMER, BIGHT ADJUSTABLE FROM $\frac{1}{4}$ " TO $\frac{1}{2}$ "; GREATEST LENGTH OF STITCH $\frac{1}{4}$ ". THREE-THREAD STITCH. FOOT LIFTER.

No.	Plate	Name
*42485	—	Arm with 15404, two each 462c, 624c, 15405, 42253 and 42487 ...
4389	5543	" Dowel Pin ...
949e	2277	" Screw ...
42001	5576	Balance Wheel, 2 $\frac{3}{16}$ " pulley, with 424c and 1354c ...
1354c	2277	" " Position Screw ...
424c	2277	" " Set Screw ...
*42229	5528	Cloth Plate ...
42230	—	Cloth Plate, complete, Nos. 42005, 42229, 42231, two 236e and three 229e
42231	5528	Cloth Plate Extension ...
229e	2277	" " " Screw ...
1437d	2277	" " Hinge Screw ...
1655e	2277	" " " Nut ...
42005	5526	" " Lock Spring ...
236c	2277	" " " Screw ...
42205	5596	Feed Bar with 1253c ...
*42333	—	" " 42205 with 42013 ...
42007	5529	" " Hinge Pin ...
1253c	5529	" " " Set Screw ...
42008	5529	" Connecting Rod with 42009 and two 1057c ...
*42371	—	" " " 42008 with 1373c and 1520c ...
*42009	—	" " " Cap ...
1057c	5529	" " " Screw ...
1373c	5529	" " " Hinge Screw ...
1520c	5529	" " " " Nut ...
42232	7383	" Dog (17 teeth, 12 teeth to the inch) ...
42447	7405	" " (14 teeth, 10 teeth to the inch) ...

NOTE.— No. 42447 is sent with this machine unless otherwise specified on order.

No.	Plate	Name
190d	5526	Feed Dog Screw ...
42011	5529	" Eccentric with two 453c ...
42094	5526	" " Cover ...
42102	5543	" " " Holder ...
283w	5543	" " " " Thumb Screw ...
19044	5539	" " " " " Washer ...
207d	5529	" " " Screw ...
453c	5529	" " " Set Screw ...
42012	5529	" Lifting Eccentric with two 462c ...
42013	5529	" " " Connection ...
462c	5529	" " " Set Screw ...
1374c	5530	" Regulating Screw Stud ...
1680c	5530	" " " " Nut ...
42290	5530	" " " " Washer ...
42014	5530	" Regulator with 233j and two 1259c ...
42015	5529	" " " Connection with 1012c ...
*42368	—	" " " 42015 with 1373c and 1520c ...
1012c	5529	" " " Adjusting Screw ...
1373c	5529	" " " Hinge Screw ...
1520c	5529	" " " " Nut ...
42016	5530	" " " Hinge Stud ...
1259c	5530	" " " Set Screw ...
233j	5530	" " " Stop Screw ...
42019	5530	" Rock Shaft ...
42020	—	Feed Rock Shaft, complete, Nos. 42019 and 42021 ...
42021	5530	Feed Rock Shaft Crank with 157e ...
157e	5530	" " " " Clamping Screw ...
42098	5530	" " " Hinge Pin ...
42079	5530	" " " " Bushing ...
1036c	5530	" " " " " Set Screw ...
*42233	—	Frame ...
42210	20797	" Rotary Shaft ...
42024	5576	" " " Bushing (front) ...
1036c	5530	" " " " (") Set Screw ...
42211	5596	" " " Crank with 1036c and 1375c ...
1375c	2277	" " " " Position Screw ...
1036c	5530	" " " " Set Screw ...
42026	5576	" " " Flanged Bushing (back) with 54967 ...
54967	7403	" " " " " (") Oil Pad (braided cotton)
1036c	5530	" " " " " (") Set Screw ...
42367	5591	" " " Front Bearing Oil Pad (braided cotton) ...
132638	2265	" Side Cover (left) with 132701 ...
132701	2268	" " " (") Handle ...
330w	2277	" " " (") Screw ...

No.	Plate	Name
42028	5526	Frame Side Cover (right, hinged) ...
42192	5560	" " " (") Lock Spring ...
330w	2277	" " " (") " " Screw ...
330w	2277	" " " (") Screw ...
42234	---	" Top Cover ...
742f	2277	" " " Screw ...
42235	7383	Guide Body ...
42236	7383	" Finger ...
50365d	7388	" " Screw ...
42237	7383	" Smoothing Plate ...
203f	5591	" " " Screw ...
7071	5595	" " " " Washer ...
42238	7383	Guide, complete, Nos. 203f, 7071, 42235 to 42237 and two 50365d
217d	5556	Guide Screw ...
7071	5595	" " Washer ...
42219	5560	Looper (left hand) ...
132870	2273	" (" ") Lever with 50117c ...
*42318	---	" (" ") " 132870 with 42053 ...
42052	2271	" (" ") " Connecting Link ...
*42384	---	" (" ") " " " 42052 with two each 1520c and 50562c
50562c	20795	" (" ") " " " Hinge Screw ...
1520c	5529	" (" ") " " " " Nut ...
42053	2272	" (" ") " Hinge Stud ...
1036c	5530	" (" ") " " " Set Screw ...
50117c	2276	" (" ") Set Screw ...
42239	7388	" (right hand) ...
42073	2271	" (" ") and Spreader Lever with 1259c ...
*42330	---	" (" ") " " " 42073 with 233d, 42078 and 42242
42221	5560	" (" ") " " " Ball Stud ...
1259c	5530	" (" ") " " " " Set Screw ...
42075	2271	" (" ") " " " Connection with 42059, 42076 and four 896c
*42076	---	" (" ") " " " Connection Cap (lower)
896c	20795	" (" ") " " " " " (") Screw
*42059	---	" (" ") " " " " Cap(upper)
896c	20795	" (" ") " " " " " (") Screw
42077	2271	" (" ") " " " " Guide ...
171f	5544	" (" ") " " " " Guide Screw

No.	Plate	Name
42403	2273	Looper (right hand) and Spreader Lever Connection Oil Tube and Bracket with 29599
29599	2272	" (" ") " " " " Connection Oil Tube Packing (felt)
42078	2271	" (" ") " " " " Hinge Pin ...
42079	5530	" (" ") " " " " " Bushing ...
1259c	5530	" (" ") " " " " " " Set Screw
197d	5556	" (" ") Screw ...
38534	5560	Needle Bar (bollow) ...
42253	5544	" " Bushing ...
462c	5544	" " " Set Screw ...
42291	5596	" " Connecting Bracket with 223f and 1057c ...
1057c	5529	" " " " " Clamping Screw ...
42055	5544	" " " " Link ...
*42326	---	" " " " " 42055 with 42104, 42291 and two 40247
40247	5544	" " " " " Hinge Pin ...
223f	5544	" " " " " " " Set Screw for 42291 ...
904c	5544	" " " " " " " " " 42104 ...
42057	5544	" " " " " Rod with 42076, 132878 and four 896c
*42383	---	" " " " " " 42057 with 42074 ...
*42372	---	" " " " " " 42383 with 42210 ...
*42076	---	" " " " " " Cap (lower) ...
896c	20795	" " " " " " " (") Screw ...
*132878	---	" " " " " " " (upper) ...
896c	20795	" " " " " " " (") Screw ...
42077	2271	" " " " " " Guide ...
171f	5544	" " " " " " " Screw ...
42103	5544	" " Crank (back) with 1258c and two 1259c ...
42074	2271	" " " (") Ball Stud ...
1259c	5530	" " " (") " " Set Screw ...
1259c	5530	" " " (") Position Screw ...
1258c	5544	" " " (") Set Screw ...
42104	5544	" " " " (front) with 904c, 1258c and 1259c ...
1259c	5530	" " " (") Position Screw ...
1258c	5544	" " " (") Set Screw ...
42105	5544	" " " Shaft ...
42487	20795	" " " " " Bushing ...
624c	20800	" " " " " " Set Screw ...
42115	5544	" " Thread Retainer Bracket ...
228d	5544	" " " " " " Screw ...
42483	20795	" " " " " " Disc ...
93c	5544	" " " " " " Screw ...
10107	5544	" " " " " " Spring ...
1728c	5544	" Clamping Nut ...

No.	Plate	Name					
42066	5544	Needle Guard
42195	5596	" " Holder
1101c	5543	" " " Screw
171f	5544	" " Screw
42240	7383	Presser Foot, complete, Nos. 233d, 42241 and 42489
42489	7388	Presser Foot Body
42241	7383	" " Chaining-off Finger
233d	5530	" " " " Screw
1321c	5591	" " Screw
39541	2272	" " " Washer
42227	2271	" Lever
42377	—	" " 42227 with 42045
42045	5542	" " Hinge Stud
1120c	5591	" " " " Set Screw
42070	2272	" " Lifter
85d	2277	" " Hinge Screw
1377c	2277	" " Screw Stud (eccentric)
1547j	5543	" " " " Nut
42071	2272	" " Spring
1378d	2277	Pressure Regulating Thumb Screw
42250	5560	Spreader
197d	5556	" Screw
2102	5556	Tension (looper, left hand) Disc
1560c	5556	" (" " ") Regulating Thumb Nut
828c	5556	" (" " ") Screw Stud
42418	—	" (" " ") " " 828c with 1560c
10148	5556	" (" " ") Spring
2102	5556	" (looper, right hand) Disc
1560c	5556	" (" " ") Regulating Thumb Nut
828c	5556	" (" " ") Screw Stud
42418	—	" (" " ") " " 828c with 1560c
10148	5556	" (" " ") Spring
17547	5556	" (" " ") Thread Guide
2102	5556	" (needle thread) Disc
1560c	5556	" (" " ") Regulating Thumb Nut
916c	5556	" (" " ") Screw Stud
44209	—	" (" " ") " " 916c with 1560c
2103	5556	" (" " ") Spring
42082	5556	" (" " ") Thread Guide
42242	7388	Thread (looper, left hand) Eyelet
233d	5530	" (" " " ") " Screw
42122	7388	" (" " " ") Nipper Spring (lower)

No.	Plate	Name					
42123	7388	Thread (looper, left hand) Nipper Spring (upper)
176d	5543	" (" " " ") " " Screw
42243	7388	" (" " " ") Pull-off
42244	7388	" (" " " ") " Eyelet
207d	5529	" (" " " ") " " Screw
42084	5556	" (" " " ") Tube
462c	5529	" (" " " ") " Set Screw
42093	5556	" (looper, right hand) Staple
190d	5556	" (" " " ") " Screw
42245	7388	" (" " " ") Take-up
197d	5556	" (" " " ") " Screw
42096	5596	" (needle) Eyelet
217j	5556	" (") " Screw
42128	2274	" (") Take-up
197d	5556	" (") " Screw
42246	7383	Throat Plate for 42232
42448	7405	" " " 42447
742f	2277	" " Screw

NOTE.—No. 42448 is sent with this machine unless otherwise specified on order.

*15404	—	Trade Mark
15405	—	" " Rivet

PARTS COMPLETE
FOR
No. 81K12 MACHINE

FOR OVEREDGING FELT, CORK OR LEATHER INSOLES, ETC. NO TRIMMER. HAS CLEARANCE BACK OF PRESSER FOOT FOR CONVENIENCE IN STITCHING AROUND CURVES. BIGHT ADJUSTABLE FROM $\frac{1}{4}$ " TO $\frac{1}{2}$ ". THREE-THREAD STITCH. FOOT LIFTER.

NOTE.—This machine can also be used for overedging automobile rugs, carpets, etc. When required for this purpose it must be so specified on order.

No.	Plate	Name
*42485	—	Arm with 15404, two each 462c, 624c, 15405, 42253 and 42487 ...
4389	5543	" Dowel Pin ...
949c	2277	" Screw ...
42001	5576	Balance Wheel, 2 $\frac{3}{16}$ " pulley, with 424c and 1354c ...
1354c	2277	" " Position Screw ...
424c	2277	" " Set Screw ...
*42229	5528	Cloth Plate ...
42231	5528	" " Extension ...
229c	2277	" " " Screw ...
42005	5526	" " Lock Spring ...
236c	2277	" " " " Screw ...
42230	—	Cloth Plate, complete, Nos. 42005, 42229, 42231, two 236c and three 229c ...
1437d	2277	Cloth Plate Hinge Screw ...
1655e	2277	" " " " Nut ...
42205	5596	Feed Bar with 1253c ...
*42333	—	" " 42205 with 42013 ...
42007	5529	" " Hinge Pin ...
1253c	5529	" " " " Set Screw ...
42008	5529	" Connecting Rod with 42009 and two 1057c ...
*42371	—	" " " 42008 with 1373c and 1520c ...
*42009	—	" " " Cap ...
1057c	5529	" " " " Screw ...
1373c	5529	" " " " Hinge Screw ...
1520c	5529	" " " " " Nut ...

No.	Plate	Name
12191	5540	Feed Dog (21 teeth, 16 teeth to the inch) ...
190d	5526	" " Screw ...
42011	5529	" Eccentric with two 453c ...
42094	5526	" " Cover ...
42102	5543	" " " Holder ...
283w	5543	" " " " Thumb Screw ...
19044	5539	" " " " " " Washer ...
207d	5529	" " " " Screw ...
453c	5529	" " " " Set Screw ...
42012	5529	" Lifting Eccentric with two 462c ...
42013	5529	" " " " Connection ...
462c	5529	" " " " Set Screw ...
1374c	5530	" Regulating Screw Stud ...
1684c	5530	" " " " Nut ...
42290	5530	" " " " Washer ...
42014	5530	" Regulator with 233j and two 1259c ...
42015	5529	" " " " Connection with 1012c ...
*42368	—	" " " " 42015 with 1373c and 1520c ...
1012c	5529	" " " " Adjusting Screw ...
1373c	5529	" " " " Hinge Screw ...
1520c	5529	" " " " " " Nut ...
42016	5530	" " " " Hinge Stud ...
1259c	5530	" " " " Set Screw ...
233j	5530	" " " " Stop Screw ...
42019	5530	" Rock Shaft ...
42020	—	Feed Rock Shaft, complete, Nos. 42019 and 42021 ...
42021	5530	Feed Rock Shaft Crank with 157e ...
157e	5530	" " " " Clamping Screw ...
42098	5530	" " " " Hinge Pin ...
42079	5530	" " " " " Bushing ...
1036c	5530	" " " " " " Set Screw ...
*42254	—	Frame ...
42210	20797	" Rotary Shaft ...
42024	5576	" " " " Bushing (front) ...
1036c	5530	" " " " " (") Set Screw ...
42211	5596	" " " " Crank with 1036c and 1375c ...
1375c	2277	" " " " " Position Screw ...
1036c	5530	" " " " " Set Screw ...
42026	5576	" " " " Flanged Bushing (back) with 54967 ...
54967	7403	" " " " " " (") Oil Pad (braided cotton) ...
1036c	5530	" " " " " " (") Set Screw ...
42367	5591	" " " " Front Bearing Oil Pad (braided cotton) ...

No.	Plate	Name
132638	2265	Frame Side Cover (left) with 132701
132701	2268	" " " (") Handle
330w	2277	" " " (") Screw
42028	5526	" " " (right, hinged)
42192	5560	" " " (") Lock Spring
330w	2277	" " " (") " " Screw
330w	2277	" " " (") Screw
42255	2263	" Top Cover
742f	2277	" " " Screw
42256	2276	Guide
217d	5556	" Screw
7071	5595	" " Washer
42219	5560	Looper (left hand)
132870	2273	" (" ") Lever with 50117c
*42318	---	" (" ") " 132870 with 42053
42052	2271	" (" ") " Connecting Link
*42384	---	" (" ") " " " 42052 with two each 1520c and 50562c
50562c	20795	" (" ") " " " Hinge Screw
1520c	5529	" (" ") " " " " " Nut
42053	2272	" (" ") " Hinge Stud
1036c	5530	" (" ") " " " Set Screw
50117c	2276	" (" ") Set Screw
42239	7388	" (right hand)
42073	2271	" (" ") and Spreader Lever with 1259c
*42330	---	" (" ") " " " 42073 with 233d, 42078 and 42242
42221	5560	" (" ") " " " Ball Stud
1259c	5530	" (" ") " " " " " Set Screw
42075	2271	" (" ") " " " Connection with 42059, 42076 and four 896c
*42076	---	" (" ") " " " Connection Cap (lower)
896c	20795	" (" ") " " " " " (") Screw
*42059	---	" (" ") " " " " " (upper)
896c	20795	" (" ") " " " " " (") Screw
42077	2271	" (" ") " " " Guide
171f	5544	" (" ") " " " " " Screw
42403	2273	" (" ") " " " Oil Tube and Bracket with 29599
29599	2272	" (" ") " " " Connection Oil Tube Packing (felt)
42078	2271	" (" ") " " " Hinge Pin

No.	Plate	Name
42079	5530	Looper (right hand) and Spreader Lever Hinge Pin Bushing
1259c	5530	" (" ") " " " " " " " " " Set Screw
197d	5556	" (" ") Screw
38534	5560	Needle Bar (hollow)
42253	5544	" " Bushing
462c	5544	" " " Set Screw
42291	5596	" " Connecting Bracket with 223f and 1057c
1057c	5529	" " " " Clamping Screw
42055	5544	" " " Link
*42326	---	" " " " 42055 with 42104, 42291 and two 40247
40247	5544	" " " " Hinge Pin
223f	5544	" " " " " " " Set Screw for 42291
904c	5544	" " " " " " " " " 42104
42057	5544	" " " " Rod with 42076, 132878 and four 896c
*42383	---	" " " " 42057 with 42074
*42372	---	" " " " 42383 with 42210
*42076	---	" " " " Cap (lower)
896c	20795	" " " " " (") Screw
*132878	---	" " " " " (upper)
896c	20795	" " " " " (") Screw
42077	2271	" " " " Guide
171f	5544	" " " " " " Screw
42103	5544	" " Crank (back) with 1258c and two 1259c
42074	2271	" " " (") Ball Stud
1259c	5530	" " " (") " " Set Screw
1259c	5530	" " " (") Position Screw
1258c	5544	" " " (") Set Screw
42104	5544	" " " (front) with 904c, 1258c and 1259c
1259c	5530	" " " (") Position Screw
1258c	5544	" " " (") Set Screw
42105	5544	" " " Shaft
42487	20795	" " " " Bushing
624c	20800	" " " " " Set Screw
42115	5544	" " Thread Retainer Bracket
228d	5544	" " " " " Screw
42483	20795	" " " " Disc
93c	5544	" " " " Screw
10107	5544	" " " " Spring
1728c	5544	" Clamping Nut
12066	5544	" Guard
42195	5596	" " Holder
1101c	5543	" " " Screw
171f	5544	" " Screw

No.	Plate	Name
42257	2269	Presser Foot with 233d and 42258 ...
42258	---	" " Chaining-off Finger ...
233d	5530	" " " " Screw ...
172c	2277	" " Screw ...
39541	2272	" " Washer ...
42259	2266	" Lever ...
42378	---	" " 42259 with 42045 ...
42045	5542	" " Hinge Stud ...
1120c	5591	" " " " Set Screw ...
42071	2272	" " Spring ...
1378d	2277	Pressure Regulating Thumb Screw ...
42250	5560	Spreader ...
197d	5556	" Screw ...
2102	5556	Tension (looper, left hand) Disc ...
1560c	5556	" (" " ") Regulating Thumb Nut ...
828c	5556	" (" " ") Screw Stud ...
42418	---	" (" " ") " " 828c with 1560c ...
10148	5556	" (" " ") Spring ...
2102	5556	" (looper, right hand) Disc ...
1560c	5556	" (" " ") Regulating Thumb Nut ...
828c	5556	" (" " ") Screw Stud ...
42418	---	" (" " ") " " 828c with 1560c ...
10148	5556	" (" " ") Spring ...
17547	5556	" (" " ") Thread Guide ...
2102	5556	" (needle thread) Disc ...
1560c	5556	" (" " ") Regulating Thumb Nut ...
916c	5556	" (" " ") Screw Stud ...
44209	---	" (" " ") " " 916c with 1560c ...
2103	5556	" (" " ") Spring ...
42082	5556	" (" " ") Thread Guide ...
42242	7388	Thread (looper, left hand) Eyelet ...
233d	5530	" (" " ") " Screw ...
42122	7388	" (" " ") Nipper Spring (lower) ...
42123	7388	" (" " ") " " (upper) ...
176d	5543	" (" " ") " " Screw ...
42243	7388	" (" " ") Pull-off ...
42244	7388	" (" " ") " Eyelet ...
207d	5529	" (" " ") " " Screw ...
42084	5556	" (" " ") Tube ...
462c	5529	" (" " ") " Set Screw ...
42093	5556	" (looper, right hand) Staple ...
190d	5556	" (" " ") " Screw ...
42127	5556	" (" " ") Take-up ...
197d	5556	" (" " ") " Screw ...

No.	Plate	Name
42096	5556	Thread (needle) Eyelet ...
217j	5556	" (") " Screw ...
42128	2274	" (") Take-up ...
197d	5556	" (") " Screw ...
42260	2269	Throat Plate ...
42261	2266	" " Extension ...
1231f	2276	" " " Screw ...
742f	2277	" " Screw ...
*15404	---	Trade Mark ...
15405	---	" " Rivet ...

Fittings

FOR 81K12 MACHINE

FOR STITCHING AROUND CORNERS ON AUTOMOBILE RUGS WITH A THREE-THREAD OVEREDGE STITCH

No.	Plate	Name
42447	7405	Feed Dog (14 teeth, 10 teeth to the inch)
42455	7388	Guide
217d	5556	" Screw
7071	5595	" " Washer
42456	7388	Looper Guard
330w	2277	" " Screw
42489	7388	Presser Foot Body
42457	7388	" " Chaining-off Finger
233d	5530	" " " " Screw
42458	7388	Presser Foot, complete, Nos. 233d, 42457 and 42489
42245	7388	Thread (looper, right hand) Take-up
197d	5556	" (" " ") " Screw
42448	7405	Throat Plate for 42447

FOR STITCHING BLANKETS, CARPETS, RUGS, ETC., WITH A THREE-THREAD OVEREDGE STITCH

No.	Plate	Name
42447	7405	Feed Dog (14 teeth, 10 teeth to the inch)
42235	7383	Guide Body
42236	7383	" Finger
50365d	7388	" " Screw
42237	7383	" Smoothing Plate
203f	5591	" " " " Screw
7071	5595	" " " " Washer
42238	7383	Guide, complete, Nos. 203f, 7071, 42235 to 42237 and two 50365d

FOR 81K12 MACHINE

FOR STITCHING BLANKETS, CARPETS, RUGS, ETC., WITH A THREE-THREAD OVEREDGE STITCH

No.	Plate	Name
42489	7388	Presser Foot Body
42241	7383	" " Chaining-off Finger
233d	5530	" " " " Screw
42240	7383	Presser Foot, complete, Nos. 233d, 42241, and 42489
42245	7388	Thread (looper, right hand) Take-up
197d	5556	" (" " ") " Screw
42448	7405	Throat Plate for 42447

PARTS COMPLETE

FOR

No. 81K22 MACHINE

FOR TRIMMING, OVEREDGING AND CLOSING SEAMS IN KNIT GOODS. FITTED WITH DOUBLE FEED DOG. THE HEIGHT OF THE BACK FEED DOG CAN BE ADJUSTED BY A HAND LEVER AT THE BACK OF THE MACHINE TO PREVENT FULLING THE EDGES WHILE STITCHING. FITTED FOR MAKING A TIGHT SEAM WITH AN INFERIOR GRADE OF YARN. BIGHT ADJUSTABLE FROM $\frac{1}{8}$ TO $\frac{3}{16}$ ", THREE-THREAD STITCH. FOOT LIFTER.

No.	Plate	Name
*42484	---	Arm with 15404, two each 462c, 624c, 15405, 42253 and 42487 ...
4389	5543	" Dowel Pin ...
949c	2277	" Screw ...
42001	5576	Balance Wheel, 2 $\frac{3}{16}$ " pulley, with 424c and 1354c ...
1354c	2277	" " Position Screw ...
424c	2277	" " Set Screw ...
*42145	---	Cloth Plate ...
42146	---	Cloth Plate, complete, Nos. 42003, 42005, 42108, 42145, two 236c and five 229c ...
42003	5526	Cloth Plate Extension (lower) ...
229c	2277	" " " (") Screw ...
42108	5526	" " " (upper) ...
229c	2277	" " " (") Screw ...
1437d	2277	" " Hinge Screw ...
1655e	2277	" " " " Nut ...
42005	5526	" " Lock Spring ...
236c	2277	" " " " Screw ...
42341	5590	Feed (back) Adjusting Lever with 967d and 42342 ...
967d	5590	" (") " " Clamping Screw ...
42342	5590	" (") " " Stud ...
42340	5590	" (") Bar ...
61c	5590	" (") " Hinge Screw ...
42149	5533	" (") Dog (3 teeth, 16 teeth to the inch) ...
203d	5591	" (") " Screw ...

No.	Plate	Name
42151	5590	Feed (front) Bar with 1253c ...
42007	5529	" (") " Hinge Pin ...
1253c	5529	" (") " " Set Screw ...
42008	5529	" (") Connecting Rod with 42009 and two 1057c ...
*42371	---	" (") " " 42008 with 1373c and 1520c ...
*42009	---	" (") " " Cap ...
1057c	5529	" (") " " Screw ...
1373c	5529	" (") " " Hinge Screw ...
1520c	5529	" (") " " " Nut ...
42152	5533	" (") Dog (17 teeth, 16 teeth to the inch) ...
190d	5556	" (") " Screw ...
42014	5529	" (") Eccentric with two 453c ...
42153	2265	" (") " Cover ...
207d	5529	" (") " " Screw ...
453c	5529	" (") " Set Screw ...
42012	5529	" (") Lifting Eccentric with two 462c ...
42013	5529	" (") " " Connection ...
462c	5529	" (") " " Set Screw ...
1374c	5530	" (") Regulating Screw Stud ...
1680c	5530	" (") " " " Nut ...
42290	5530	" (") " " Washer ...
42014	5530	" (") Regulator with 233j and two 1259c ...
42015	5529	" (") " Connection with 1012c ...
*42368	---	" (") " " 42015 with 1373c and 1520c ...
1012c	5529	" (") " " Adjusting Screw ...
1373c	5529	" (") " " Hinge Screw ...
1529c	5529	" (") " " " Nut ...
42016	5530	" (") " Hinge Stud ...
42017	5529	" (") " Indicator ...
42018	5530	" (") " " Plate ...
337d	5530	" (") " " " Screw ...
207d	5529	" (") " " " Screw ...
1259c	5530	" (") " " Set Screw ...
233j	5530	" (") " " Stop Screw ...
42019	5530	" (") Rock Shaft ...
42020	---	Feed (front) Rock Shaft, complete, Nos. 42019 and 42021 ...
42021	5530	Feed (front) Rock Shaft Crank with 157c ...
157c	5530	" (") " " " Clamping Screw ...
42098	5530	" (") " " Hinge Pin ...
42079	5530	" (") " " " Bushing ...
1036c	5530	" (") " " " " Set Screw ...
*42022	---	Frame ...
42023	5576	" Rotary Shaft ...
42024	5576	" " " Bushing (front) ...

No. 81K22 MACHINE PARTS

No.	Plate	Name
1036c	5530	Frame Rotary Shaft Bushing (front) Set Screw ...
42110	2272	" " " Crank with 1036c and 1375c ...
1375c	2277	" " " " Position Screw ...
1036c	5530	" " " " Set Screw ...
42026	5576	" " " Flanged Bushing (back) with 54967 ...
54967	7403	" " " " (") Oil Pad (braided cotton)
1036c	5530	" " " " (") Set Screw ...
42367	5591	" " " Front Bearing Oil Pad (braided cotton) ...
132560	2265	" Side Cover (left) with 132701 ...
132701	2268	" " " (") Handle ...
330w	2277	" " " (") Screw ...
42028	5526	" " " (right, hinged) ...
42101	5543	" " " (") Lock Spring ...
330w	2277	" " " (") Screw ...
42469	2264	" Top Cover ...
132650	2268	" " " Extension ...
42102	5543	" " " " Holder ...
42324	—	" " " " 42102, with 42101, 42153, 132650, two each 176d and 207d
283w	5543	" " " " Holder Thumb Screw ...
19044	5539	" " " " " Washer ...
176d	5543	" " " " Screw ...
742f	2277	" " " Screw ...
42111	5542	Knife (movable) ...

NOTE.—Two No. 42111 are sent with this machine.

42112	5542	Knife (movable) Gib ...
42035	5542	" (") Holder ...
42113	—	" (") " 42035 with 133f, 42037, 42040, 42112 and two 404d
42037	5542	" (") " Cap ...
404d	5542	" (") " " Screw ...
42038	5542	" (") " Guide with 336f ...
42039	5542	" (") " " Plate ...
621d	5542	" (") " " " Screw ...
336f	5542	" (") " " Set Screw ...
133f	5542	" (") " " Screw ...
42040	5542	" (") " " Extension Pin ...
42041	5542	" (") " " Spring ...
42042	5542	" (") " Lever ...
42043	5542	" (") " " Connection with 42044 and two 175e ...
*42369	—	" (") " " 42043 with 1373c and 1520c
*42044	—	" (") " " Cap ...
175e	5542	" (") " " " Screw ...
1373c	5542	" (") " " " Hinge Screw ...
1520c	5529	" (") " " " " Nut ...

No. 81K22 MACHINE PARTS

No.	Plate	Name
42045	5542	Knife (movable) Lever Hinge Stud ...
1229c	5542	" (") " " " " Set Screw ...
42046	5543	" (stationary) with 42049 ...

NOTE.—Two No. 42046 are sent with this machine.

42048	5543	Knife (stationary) Clamping Stud ...
1534d	5543	" (") " " " Thumb Nut ...
132766	2267	" (") " Holder ...
1376c	5543	" (") " " Regulating Thumb Screw ...
1101c	5543	" (") " " Screw ...
440f	5543	" (") " " Stop Screw ...
1547j	5543	" (") " " " " Nut ...
42049	5543	" (") " Stud ...
42114	2272	Looper (left hand) ...
132870	2273	" (" ") Lever with 50117c ...
*42318	—	" (" ") " 132870 with 42053 ...
42052	2271	" (" ") " " Connecting Link ...
42384	—	" (" ") " " " 42052 with two each 1520c and 50562c
50562c	20795	" (" ") " " " Hinge Screw ...
1520c	5529	" (" ") " " " " Nut ...
42053	2272	" (" ") " " Hinge Stud ...
1036c	5530	" (" ") " " " Set Screw ...
50117c	2276	" (" ") Set Screw ...
42166	2272	" (right hand) ...
42073	2271	" (" ") and Spreader Lever with 1259c ...
*42330	—	" (" ") " " " 42073 with 233d, 42078 and 42242
42074	2271	" (" ") " " " Ball Stud ...
1259c	5530	" (" ") " " " " Set Screw ...
42075	2271	" (" ") " " " Connection with 42059, 42076 and four 896c
42416	—	" (" ") " " " Connection 42075 with 42074
42379	—	" (" ") " " " " 42416 with 42110
*42076	—	" (" ") " " " " Cap (lower)
896c	20795	" (" ") " " " " " (") Screw
*42059	—	" (" ") " " " " Cap (upper)
896c	20795	" (" ") " " " " " (") Screw
42077	2271	" (" ") " " " " Guide ...
171f	5544	" (" ") " " " " " Screw
42403	2273	" (" ") " " " " Oil Tube and Bracket with 29599

No.	Plate	Name
29599	2272	Looper (right hand) and Spreader Lever Connection Oil Tube
		Packing (felt)
42078	2271	" (" ") " " " Hinge Pin ...
42079	5530	" (" ") " " " " " Bushing ...
1036c	5530	" (" ") " " " " " " " Set Screw
42054	5544	Needle Bar ...
42253	5544	" " Bushing ...
462c	5544	" " " Set Screw ...
42061	5544	" " Connecting Bracket with 187d and 223f ...
187d	5544	" " " " Clamping Screw ...
42055	5544	" " " Link ...
*42335	—	" " " " 42055 with 42061, 42104 and two 40247
40247	5544	" " " " Hinge Pin ...
223f	5544	" " " " " " " Set Screw for 42061 ...
904c	5544	" " " " " " " " " " 42104 ...
42057	5544	" " " " Rod with 42076, 132878 and four 896c ...
*42383	—	" " " " " 42057 with 42074 ...
*42374	—	" " " " " 42383 with 42023 ...
*42076	—	" " " " " Cap (lower) ...
896c	20795	" " " " " " (") Screw ...
*132878	—	" " " " " " (upper) ...
896c	20795	" " " " " " (") Screw ...
42077	2271	" " " " " Guide ...
171f	5544	" " " " " " Screw ...
42103	5544	" " Crank (back) with 1258c and two 1259c ...
42074	2271	" " " (") Ball Stud ...
1259c	5530	" " " (") " " Set Screw ...
1259c	5530	" " " (") Position Screw ...
1258c	5544	" " " (") Set Screw ...
42104	5544	" " " (front) with 904c, 1258c and 1259c ...
1259c	5530	" " " (") Position Screw ...
1258c	5544	" " " (") Set Screw ...
42105	5544	" " " Shaft ...
42487	20795	" " " " Bushing ...
624c	20800	" " " " " Set Screw ...
42115	5544	Needle Bar Thread Retainer Bracket ...
228d	5544	" " " " " " Screw ...
42483	20795	" " " " " Disc ...
93c	5544	" " " " " Screw ...
10107	5544	" " " " " Spring ...
1728c	5544	" Clamping Nut ...
42066	5544	" Guard ...
171f	5544	" " Screw ...

No.	Plate	Name
42157	—	Presser Foot Body ...
42470	—	" " Chaining-off Finger ...
233d	5530	" " " " " Screw ...
9320	—	" " Hinge Pin ...
42159	—	" " Plate ...
14058	2276	" " Spring ...
42160	2273	" " " Adjusting Pin ...
464c	2276	" " " " " Set Screw ...
42471	2270	Presser Foot (spring hinged), complete, Nos. 233d, 464c, 9320, 14058, 42157, 42159, 42160 and 42470 ...
1324c	2277	Presser Foot Screw ...
39541	2272	" " " Washer ...
42069	5576	" Lever ...
42376	—	" " 42069 with 42015 ...
42015	5542	" " Hinge Stud ...
1120c	5591	" " " " Set Screw ...
42070	2272	" " Lifter ...
85d	2277	" " " Hinge Screw ...
1377c	2277	" " Screw Stud (eccentric) ...
1547j	5543	" " " " Nut ...
42071	2272	" " Spring ...
1378d	2277	Pressure Regulating Thumb Screw ...
2102	5556	Tension (looper, left hand) Disc ...
1560c	5556	" (" " ") Regulating Thumb Nut ...
828c	5556	" (" " ") Screw Stud ...
42418	—	" (" " ") " " 828c with 1560c ...
42121	5556	" (" " ") Spring ...
2102	5556	" (looper, right hand) Disc ...
1560c	5556	" (" " ") Regulating Thumb Nut ...
828c	5556	" (" " ") Screw Stud ...
42418	—	" (" " ") " " 828c with 1560c ...
10148	5556	" (" " ") Spring ...
17547	5556	" (" " ") Thread Guide ...
2102	5556	" (needle thread) Disc ...
1560c	5556	" (" ") Regulating Thumb Nut ...
916c	5556	" (" ") Screw Stud ...
11209	—	" (" ") " " 916c with 1560c ...
2103	5556	" (" ") Spring ...
42082	5556	" (" ") Thread Guide ...
42242	7388	Thread (looper, left hand) Eyelet ...
233d	5530	" (" " ") " Screw ...
42122	7388	" (" " ") Nipper Spring (lower) ...
42123	7388	" (" " ") " " (upper) ...
176d	5543	" (" " ") " " Screw ...

No.	Plate	Name						
42124	5590	Thread (looper, left hand) Pull-off
42125	5590	" (" " ") " Eyelet
233d	5530	" (" " ") " " Screw
42084	5556	" (" " ") Tube
462c	5529	" (" " ") " Set Screw
42126	2266	" (looper, right hand) Pull-off
42093	5556	" (" " ") Staple
190d	5556	" (" " ") " Screw
42127	5556	" (" " ") Take-up
197d	5556	" (" " ") " Screw
42096	5556	" (needle) Eyelet
217j	5556	" (") " Screw
42162	2266	" (") Take-up
197d	5556	" (") " Screw
42472	2270	Throat Plate
742f	2277	" " Screw
*15404	---	Trade Mark
15405	---	" " Rivet

PARTS COMPLETE

FOR

No. 81K23 MACHINE

FOR TRIMMING AND OVERSEAMING POCKETS FOR TROUSERS. THIS MACHINE HAS AN INCREASED WIDTH AND LIFT OF KNIFE TO ACCOMMODATE THE HEAVIER GRADES OF MATERIAL. BIGHT ADJUSTABLE FROM $\frac{1}{16}$ " TO $\frac{7}{32}$ ". THREE-THREAD STITCH. FOOT LIFTER. BALANCE WHEEL No. 42001. SPEED 3300.

No.	Plate	Name						
*42184		Arm with 15404, two each 462c, 624c, 15405, 12253 and 42487
4389	5513	" Dowel Pin
949c	2277	" Screw
42001	5576	Balance Wheel, 2 $\frac{3}{16}$ " pulley, with 424c and 1351c
1351c	2277	" " Position Screw
424c	2277	" " Set Screw
*42002	5526	Cloth Plate
42003	5526	" " Extension (lower)
229e	2277	" " " (") Screw
42108	5526	" " " (upper)
229e	2277	" " " (") Screw
42005	5526	" " Lock Spring
236c	2277	" " " " Screw
42107		Cloth Plate, complete, Nos. 42002, 42003, 42005, 42108, two 236c and five 229e
1437d	2277	Cloth Plate Hinge Screw
1655e	2277	" " " " Nut
42006	5529	Feed Bar with 1253c
*42327		" " 42006 with 42013
42007	5529	" " Hinge Pin
1253c	5529	" " " " Set Screw
42008	5529	" Connecting Rod with 42009 and two 1057c
*42371		" " " 42008 with 1373c and 1520c
*42009		" " " Cap
1057c	5529	" " " " Screw
1373c	5529	" " " Hinge Screw
1520c	5529	" " " " " Nut

No.	Plate	Name			
42165	5592	Feed Dog (24 teeth, 16 teeth to the inch)
190d	5556	" " Screw
42011	5529	" Eccentric with two 453e
42094	5526	" " Cover
207d	5529	" " " Screw
453c	5529	" " Set Screw
42208	5596	" Lifting Eccentric with two 462c
42013	5529	" " " Connection
462c	5529	" " " Set Screw
1374c	5530	" Regulating Screw Stud
1680c	5530	" " " " Nut
42290	5530	" " " " Washer
42014	5530	" Regulator with 233j and two 1259c
42015	5529	" " Connection with 1012e
*42368	---	" " " 42015 with 1373c and 1520c
1012e	5529	" " " Adjusting Screw
1373c	5529	" " " Hinge Screw
1520c	5529	" " " " " Nut
42016	5530	" " Hinge Stud
42017	5529	" " Indicator
42018	5530	" " " Plate
337d	5530	" " " " Screw
207d	5529	" " " " Screw
1259c	5530	" " Set Screw
233j	5530	" " Stop Screw
42019	5530	" Rock Shaft
42020	---	Feed Rock Shaft, complete, Nos. 42019 and 42021
42021	5530	Feed Rock Shaft Crank with 157e
157e	5530	" " " " Clamping Screw
42098	5530	" " " Hinge Pin
42079	5530	" " " " Bushing
1036c	5530	" " " " " Set Screw
*42022	---	Frame
42023	5576	" Rotary Shaft
42024	5576	" " " Bushing (front)
1036c	5530	" " " " (") Set Screw
42110	2272	" " " Crank with 1036c and 1375c
1375c	2277	" " " " Position Screw
1036c	5530	" " " " Set Screw
42026	5576	" " " Flanged Bushing (back) with 54967
54967	7403	" " " " " (") Oil Pad (braided cotton)
1036c	5530	" " " " " (") Set Screw
42367	5591	" " " Front Bearing Oil Pad (braided cotton)

No.	Plate	Name			
132560	2265	Frame Side Cover (left) with 132701
132701	2268	" " " (") Handle
330w	2277	" " " (") Screw
42028	5526	" " " (right, hinged)
42101	5543	" " " (") Lock Spring
330w	2277	" " " (") Screw
42029	5576	" Top Cover
42212	5596	" " " Extension
42102	5543	" " " " Holder
*12329	---	" " " " " 42102 with 42094 and two 207d
*12334	---	" " " " " 42329 with 42101, 42212 and two 176d
283w	5543	" " " " " Thumb Screw
19014	5539	" " " " " " " Washer
176d	5543	" " " " " Screw
742f	2277	" " " " Screw
42305	2267	Knife (movable)
<i>NOTE.—Two No. 42305 are sent with this machine.</i>					
42306	2267	Knife (movable) Gib
132926	2267	" (") Holder
132927	---	" (") " 132926 with 133f, 42040, 42306, 132928 and two 220e
132928	---	" (") " Cap
220e	5541	" (") " " Screw
42038	5542	" (") " Guide with 336f
42039	5542	" (") " " Plate
621d	5542	" (") " " " Screw
336f	5542	" (") " " " Set Screw
133f	5542	" (") " " Screw
42040	5542	" (") " " Extension Pin
42041	5542	" (") " " Spring
42042	5542	" (") Lever
42217	5560	" (") " Connection with 42218 and two 175e
*42370	---	" (") " " 42217 with 1373c and 1520c
*42218	---	" (") " " Cap
175e	5542	" (") " " " Screw
1373c	5542	" (") " " " Hinge Screw
1520c	5529	" (") " " " " Nut
42045	5542	" (") " " Hinge Stud
1229c	5542	" (") " " " Set Screw
42309	20795	" (stationary) with 42049
<i>NOTE.—Two No. 42309 are sent with this machine.</i>					
42310	20795	Knife (stationary) Clamping Stud
1534d	5543	" (") " " Thumb Nut
132767	2267	" (") Holder

No.	Plate	Name
1376c	5543	Knife (Stationary) Holder Regulating Thumb Screw ...
1101c	5543	" (") " Screw ...
440f	5543	" (") " Stop Screw ...
1547j	5543	" (") " " " Nut ...
42049	5543	" (") Stud ...
42114	2272	Looper (left hand) ...
132870	2273	" (" ") Lever with 50117c ...
*42318	—	" (" ") " 132870 with 42053 ...
42052	2271	" (" ") " Connecting Link ...
42384	—	" (" ") " " " 42052 with two each 1520c and 50562c
50562c	20795	" (" ") " " " Hinge Screw ...
1520c	5529	" (" ") " " " " " Nut ...
42053	2272	" (" ") " Hinge Stud ...
1036c	5530	" (" ") " " " Set Screw ...
50117c	2276	" (" ") Set Screw ...
42166	2272	" (right hand) ...
42073	2271	" (" ") and Spreader Lever with 1259c ...
*42330	—	" (" ") " " " 42073 with 233d, 42078 and 42242
42074	2271	" (" ") " " " Ball Stud ...
1259c	5530	" (" ") " " " " Set Screw ...
42075	2271	" (" ") " " " Connection with 42059, 42076 and four 896c
42416	—	" (" ") " " " Connection 42075 with 42074
42379	—	" (" ") " " " 42416 with 42110
*42076	—	" (" ") " " " Cap (lower)
896c	20795	" (" ") " " " " (") Screw
*42059	—	" (" ") " " " Cap (upper)
896c	20795	" (" ") " " " " (") Screw
42077	2271	" (" ") " " " Guide ...
171f	5544	" (" ") " " " " Screw ...
42403	2273	" (" ") " " " Oil Tube and Bracket with 29599
29599	2272	" (" ") " " " Connection Oil Tube Packing (felt)
42078	2271	" (" ") " " " Hinge Pin ...
42079	5530	" (" ") " " " " Bushing ...
1259c	5530	" (" ") " " " " " Set Screw
197d	5556	" (" ") Screw ...

No.	Plate	Name
42054	5544	Needle Bar ...
42253	5544	" " Bushing ...
462c	5544	" " " Set Screw ...
42061	5544	" " Connecting Bracket with 187d and 223f ...
187d	5544	" " " " Clamping Screw ...
42055	5544	" " " Link ...
*42335	—	" " " " 42055 with 42061, 42104 and two 40247
40247	5544	" " " " Hinge Pin ...
223f	5544	" " " " " " Set Screw for 42061 ...
904c	5544	" " " " " " " " 42104 ...
42057	5544	" " " Rod with 42076, 132878 and four 896c ...
*42383	—	" " " " 42057 with 42074 ...
*42374	—	" " " " 42383 with 42023 ...
*42076	—	" " " " Cap (lower) ...
896c	20795	" " " " " (") Screw ...
*132878	—	" " " " " (upper) ...
896c	20795	" " " " " (") Screw ...
42077	2271	" " " " Guide ...
171f	5544	" " " " " " Screw ...
42103	5544	" " Crank (back) with 1258c and two 1259c ...
42074	2271	" " " (") Ball Stud ...
1259c	5530	" " " (") " " Set Screw ...
1259c	5530	" " " (") Position Screw ...
1258c	5544	" " " (") Set Screw ...
42104	5544	" " " (front) with 904c, 1258c and 1259c ...
1259c	5530	" " " (") Position Screw ...
1258c	5544	" " " (") Set Screw ...
42105	5544	" " " Shaft ...
42487	20795	" " " " Bushing ...
624c	20800	" " " " " Set Screw ...
42115	5544	" " Thread Retainer Bracket ...
228d	5544	" " " " " " Screw ...
10106	5544	" " " " Disc ...
93c	5544	" " " " Screw ...
10107	5544	" " " " Spring ...
1728c	5544	" Clamping Nut ...
42066	5544	" Guard ...
171f	5544	" " Screw ...
42168	5592	Presser Foot Chaining-off Finger ...
233d	5530	" " " " Screw ...
42120	5592	" " Extension ...

No.	Plate	Name
197f	5556	Presser Foot Extension Screw
42461	7397	" " Hinge Pin
42480	—	" " Plate
42169	—	" " Shank
42481	2269	Presser Foot (hinged), complete, Nos. 197f, 233d, 42120, 42168, 42169, 42461 and 42480
1324c	2277	Presser Foot Screw
39541	2272	" " " Washer
42069	5576	Presser Lever
42376	—	" " 42069 with 42045
42045	5542	" " Hinge Stud
1120c	5591	" " " " Set Screw
42070	2272	" " Lifter
85d	2277	" " Hinge Screw
1377c	2277	" " Screw Stud (eccentric)
1547j	5543	" " " " Nut
42071	2272	" " Spring
1378d	2277	Pressure Regulating Thumb Screw
132631	2276	Spreader
197d	5556	" Screw
2102	5556	Tension (looper, left hand) Disc
1560c	5556	" (" " ") Regulating Thumb Nut
828c	5556	" (" " ") Screw Stud
42418	—	" (" " ") " " 828c with 1560c
42121	5556	" (" " ") Spring
2102	5556	" (looper, right hand) Disc
1560c	5556	" (" " ") Regulating Thumb Nut
828c	5556	" (" " ") Screw Stud
42418	—	" (" " ") " " 828c with 1560c
10148	5556	" (" " ") Spring
17547	5556	" (" " ") Thread Guide
2102	5556	" (needle thread) Disc
1560c	5556	" (" " ") Regulating Thumb Nut
916c	5556	" (" " ") Screw Stud
44209	—	" (" " ") " " 916c with 1560c
8238	5556	" (" " ") Spring
2103	5556	" (" " ") " used in sewing very heavy pockets in trousers
42082	5556	" (" " ") Thread Guide

No.	Plate	Name
42242	7388	Thread (looper, left hand) Eyelet
233d	5530	" (" " ") " Screw
42122	7388	" (" " ") Nipper Spring (lower)
42123	7388	" (" " ") " " (upper)
176d	5543	" (" " ") " " Screw
42124	5590	" (" " ") Pull-off
42125	5590	" (" " ") " Eyelet
233d	5530	" (" " ") " " Screw
42081	5556	" (" " ") Tube
462c	5529	" (" " ") " Set Screw
42126	2266	" (looper, right hand) Pull-off
42093	5556	" (" " ") Staple
190d	5556	" (" " ") " Screw
42127	5556	" (" " ") Take-up
197d	5556	" (" " ") " Screw
42096	5556	" (needle) Eyelet
217j	5556	" (") " Screw
42128	2274	" (") Take-up
197d	5556	" (") " Screw
42482	2269	Throat Plate
742f	2277	" " Screw
*15404	—	Trade Mark
15405	—	" " Rivet

PARTS COMPLETE

FOR

No. 81K24 MACHINE

FOR TRIMMING AND JOINING THE ABUTTED EDGES OF PIECE GOODS. THE BIGHT IS ADJUSTABLE FROM $\frac{5}{16}$ " TO $\frac{3}{8}$ ". THE MACHINE IS REGULARLY FURNISHED FOR SINGLE THREAD CHAIN STITCH. IF SO ORDERED, IT CAN BE FITTED FOR TWO-THREAD CHAIN STITCH, FOOT LIFTER, BALANCE WHEEL NO. 42001. DIAMETER OF BELT GROOVE $2\frac{1}{16}$ ". SPEED UP TO 3000.

NOTE.--The machine can also be furnished for $\frac{1}{4}$ in. bight for folded or abutted edge.

No.	Plate	Name
*42185	--	Arm with 15404, two each 462c, 624c, 15405, 42253 and 42187 ...
4389	5543	" Dowel Pin ...
949c	2277	" Screw ...
42001	5576	Balance Wheel, $2\frac{3}{16}$ " pulley, with 424c and 1354c ...
1354c	2277	" " Position Screw ...
424c	2277	" " Set Screw ...
132501	2264	Cloth Plate ...
42231	5528	" " Extension (lower) ...
229e	2277	" " " (") Screw ...
132502	2273	" " " (upper) ...
229e	2277	" " " (") Screw ...
132503	--	Cloth Plate, complete, Nos. 42005, 42231, 132501, 132502, two 236c and five 229e ...
1437d	2277	Cloth Plate Hinge Screw ...
1655e	2277	" " " " Nut ...
42005	5526	" " Lock Spring ...
236c	2277	" " " " Screw ...
42205	5596	Feed Bar with 1253c ...
*42333	--	" " 42205 with 42013 ...
42007	5529	" " Hinge Pin ...
1253c	5529	" " " " Set Screw ...
42008	5529	" Connecting Rod with 42009 and two 1057c ...
*42371	--	" " " 42008 with 1373c and 1520c ...

No.	Plate	Name
*42009	--	Feed Connecting Rod Cap ...
1057c	5529	" " " " Screw ...
1373c	5529	" " " " Hinge Screw ...
1520c	5529	" " " " " Nut ...
132501	20793	" Dog (14 teeth, 10 teeth to the inch) for 132521 ...
190d	5556	" " Screw ...
42011	5529	" Eccentric with two 453c ...
132505	2268	" " Cover ...
42102	5543	" " " Holder ...
132604	--	" " " " 42102 with 12101, 132505, 132510, two each 190d and 207d ...
283w	5543	" " " " Thumb Screw ...
19044	5539	" " " " " Washer ...
207d	5529	" " " " Screw ...
453c	5529	" " Set Screw ...
132506	2268	" Lifting Eccentric with two 462c ...
42013	5529	" " " Connection ...
462c	5529	" " " Set Screw ...
1374c	5530	" Regulating Screw Stud ...
1680c	5530	" " " " Nut ...
42290	5530	" " " " Washer ...
42014	5530	" Regulator with 233j and two 1259c ...
42015	5529	" " Connection with 1012c ...
*42368	--	" " " 42015 with 1373c and 1520c ...
1012c	5529	" " " Adjusting Screw ...
1373c	5529	" " " Hinge Screw ...
1520c	5529	" " " " " Nut ...
42016	5530	" " Hinge Stud ...
1259c	5530	" " Set Screw ...
233j	5530	" " Stop Screw ...
42019	5530	" Rock Shaft ...
42021	5530	" " " Crank with 157e ...
157e	5530	" " " Clamping Screw ...
42020	--	Feed Rock Shaft, complete, Nos. 42019 and 42021 ...
42098	5530	Feed Rock Shaft Hinge Pin ...
42079	5530	" " " " " Bushing ...
1036c	5530	" " " " " Set Screw ...
*132507	--	Frame ...
42210	20797	" Rotary Shaft ...
42024	5576	" " " Bushing (front) ...
1036c	5530	" " " " (") Set Screw ...
42211	5596	" " " Crank with 1036c and 1375c ...
1375c	2277	" " " " Position Screw ...
1036c	5530	" " " " Set Screw ...

No.	Plate	Name
42026	5576	Frame Rotary Shaft Flanged Bushing (back) with 54967 ...
54967	7403	" " " " " (") Oil Pad (braided cotton)
1036c	5530	" " " " " (") Set Screw ...
42367	5591	" " " Front Bearing Oil Pad (braided cotton) ...
132638	2265	" Side Cover (left) with 132701 ...
132701	2268	" " " (") Handle ...
330w	2277	" " " (") Screw ...
42028	5526	" " " (right, hinged) ...
42101	5543	" " " (") Lock Spring ...
190d	5556	" " " (") " Screw ...
330w	2277	" " " (") Screw ...
132508	20797	" Top Cover ...
132098	2268	" " " Extension ...
132510	---	" " " " 132098 with 132511 and two 337w
132511	2266	" " " " Chaining-off Finger ...
337w	5530	" " " " " Screw ...
190j	5556	" " " " Screw ...
742f	2277	" " " Screw ...
42305	2267	Knife (movable) ...
<i>NOTE.—Two No. 42305 are sent with this machine.</i>		
42306	2267	Knife (movable) Gib ...
132926	2267	" (") Holder ...
132927	---	" (") " 132926 with 133f, 42040, 42306, 132928 and two 220e
132928	---	" (") " Cap ...
220e	5541	" (") " " Screw ...
42038	5542	" (") " Guide with 336f ...
42039	5542	" (") " " Plate ...
621d	5542	" (") " " " Screw ...
336f	5542	" (") " " Set Screw ...
133f	5542	" (") " " Screw ...
42040	5542	" (") " " Extension Pin ...
42041	5542	" (") " Spring ...
42042	5542	" (") Lever ...
132512	2267	" (") " Bracket with 1036c ...
949e	2277	" (") " " Screw ...
42217	5560	" (") " Connection with 42218 and two 175e ...
*42370	---	" (") " " 42217 with 1373c and 1520c
*42218	---	" (") " " Cap ...
175e	5542	" (") " " " Screw ...
1373c	5542	" (") " " Hinge Screw ...
1520c	5529	" (") " " " Nut ...
42045	5542	" (") " Hinge Stud ...
1036c	5530	" (") " " " Set Screw ...
42309	20795	" (stationary) with 42049 ...

NOTE.—Two No. 42309 are sent with this machine.

No.	Plate	Name
42310	20795	Knife (stationary) Clamping Stud ...
1531d	5543	" (") " " Thumb Nut ...
132513	20795	" (") Holder ...
1376c	5543	" (") " Regulating Thumb Screw ...
1101c	5543	" (") " Screw ...
42049	5543	" (") Stud ...
132514	20795	Looper ...
132870	2273	" Lever with 50117c ...
*42318	---	" " 132870 with 42053 ...
42052	2271	" " Connecting Link ...
*42384	---	" " " " 42052 with two each 1520c and 50562c
50562c	20795	" " " " Hinge Screw ...
1520c	5529	" " " " " Nut ...
42053	2272	" " Hinge Stud ...
1036c	5530	" " " " Set Screw ...
50117c	2276	" Set Screw ...
38534	5560	Needle Bar (hollow) ...
42253	5544	" " Bushing ...
462c	5544	" " " Set Screw ...
12291	5596	" " Connecting Bracket with 223f and 1057c ...
1057c	5529	" " " " Clamping Screw ...
42055	5544	" " " Link ...
*42326	---	" " " " 42055 with 42104, 42291 and two 40247
40247	5544	" " " " Hinge Pin ...
223f	5544	" " " " " Set Screw for 42291 ...
901c	5544	" " " " " " " 42104 ...
42057	5544	" " " Rod with 42076, 132878 and four 896c ...
*42383	---	" " " " 42057 with 42074 ...
*42372	---	" " " " 42383 with 42210 ...
*42076	---	" " " " Cap (lower) ...
896c	20795	" " " " " (") Screw ...
*132878	---	" " " " Cap (upper) ...
896c	20795	" " " " " (") Screw ...
42077	2271	" " " " Guide ...
171f	5544	" " " " " Screw ...
42103	5544	" " Crank (back) with 1258c and two 1259c ...
42074	2271	" " " (") Ball Stud ...
1259c	5530	" " " (") " Set Screw ...
1259c	5530	" " " (") Position Screw ...
1258c	5544	" " " (") Set Screw ...
42104	5544	" " " (front) with 901c, 1258c and 1259c ...
1259c	5530	" " " (") Position Screw ...
1258c	5544	" " " (") Set Screw ...

No.	Plate	Name					
42105	5544	Needle Bar Crank Shaft
42487	20795	" " " " Bushing
624c	20800	" " " " Set Screw
42115	5544	" " Thread Retainer Bracket
228d	5544	" " " " " Screw
42483	20795	" " " " Disc
93c	5544	" " " " Screw
10107	5544	" " " " Spring
1737c	20795	" Clamping Nut
132515	2266	" Guard
171f	5544	" " Screw
132516	20793	Presser Foot with 233d and 132517
132517	20793	" " Chaining-off Finger
233d	5530	" " " " Screw
1324c	5591	" " Screw
39541	2272	" " " Washer
132518	20797	" Lever
132605	—	" " 132518 with 42045
42045	5542	" " Hinge Stud
1120c	5591	" " " " Set Screw
132519	20797	" " Lifter
50378f	20795	" " " Screw (back)
1547j	5543	" " " " (") Nut
190j	5556	" " " " (front)
42071	2272	" " Spring
1378d	2277	Pressure Regulating Thumb Screw
42250	5560	Spreader
42073	2271	" Lever with 1259c
42221	5560	" " Ball Stud
1259c	5530	" " " " Set Screw
42075	2271	" " Connection with 42059, 42076 and four 896e
*42386	—	" " " 42075 with 42211 and 42221
*42076	—	" " " Cap (lower)
896e	20795	" " " " (") Screw
*42059	—	" " " " (upper)
896e	20795	" " " " (") Screw
42077	2271	" " " Guide
171f	5544	" " " Screw
42403	2273	" " " Oil Tube and Bracket with 29599
1094d	20795	" " " " " " " Screw
29599	2272	" " " " " Packing (felt)
42078	2271	" " Hinge Pin
42079	5530	" " " " Bushing
1259c	5530	" " " " Set Screw
197d	5556	" Screw

No.	Plate	Name					
2102	5556	Tension (needle thread) Disc
1560c	5556	" (" ") Regulating Thumb Nut
916c	5556	" (" ") Screw Stud
41209	—	" (" ") " " 916c with 1560c
10148	5556	" (" ") Spring
42082	5556	" (" ") Thread Guide
42084	5556	Thread (looper) Tube
462c	5529	" (") " Set Screw
132520	2268	" (needle) Eyelet
217j	5556	" (") " Screw
132883	2266	" (") Take-up
197d	5556	" (") " Screw
132521	20793	Throat Plate
742f	2277	" " Screw
*15404	—	Trade Mark
15405	—	" " Rivet

Parts Required to Change from Single Thread Chain Stitch to a Two-Thread Chain Stitch

No.	Plate	Name
42219	5560	Looper, in place of 132514
2102	5556	Tension (looper thread) Disc
1560c	5556	" (" ") Regulating Thumb Nut
828c	5556	" (" ") Screw Stud
42418	—	" (" ") " " 828c with 1560c
10148	5556	" (" ") Spring

NOTE.—The above Tension Parts replace Spreader Lever Connection Oil Tube and Bracket Screw No. 1094.

42242	7388	Thread (looper) Eyelet
233j	5530	" (") " Screw
42096	5556	" (needle) Eyelet, in place of 132520
42128	2274	" (") Take-up, in place of 42162

Accessories

No.	Plate	Name
1407c	5563	Machine Base Thumb Screw for 3" table
1408e	5563	" " " " 2" "
14063	2272	" " " " Spring
9842	2272	" " " " Washer
120342	2275	Oiler (copper plated) with 120343
120343	2275	" Spout, 3 $\frac{1}{4}$ " long
120440	2275	Screw Driver
42090	2275	Threading Wire
120341	2274	Tweezers (curved)
42089	2276	Wrench for 1324, 1374 and 1629
8908	2274	" " 1520 and 1655
80107	2274	" " 1528, 1547 and 1550

Bench Stand

FOR 81K2, 81K5 AND 81K13 MACHINES

No.	Plate	Name
79582	—	Bench Stand with 27998, two each 28291, wood screws 1 $\frac{1}{2}$ " No. 14 and eight wood screws $\frac{5}{8}$ " No. 5
28291	20800	Cover Hinge
27998	20800	Cover Hook and Eye (brass) with wood screw $\frac{1}{2}$ " No. 5

Machine Base

No.	Plate	Name
42086	5564	Machine Base with three wood screws 1 $\frac{1}{4}$ " No. 12, four each 935e 4718, 42088 and 66707
4718	2272	" " Cushion (felt)
42088	2272	" Cushion (felt)
935e	2277	" " Screw
66707	7403	" " Washer

Chain Cutter

FOR 81K6 MACHINE

No.	Plate	Name
42410	7403	Chain Cutting Blade (lower)
217d	5556	" " " (") Screw
42411	7403	" " " (upper)
217d	5556	" " " (") Screw
42412	7401	Frame Top Cover
42413	7401	Lifting Lever
42414	—	Chain Cutter, complete, Nos. 42410 to 42413 and four 217d

Foot Lifters

FOOT LIFTER

FOR 81K1 TO 81K9, 81K11, 81K13, 81K16 AND 81K20 TO 81K22 MACHINES

No.	Plate	Name
6439	—	Chain, 36" to 45", with 56864 and 56865
<i>NOTE:—When ordering No. 6439 state length required.</i>		
4879	2273	Chain Connecting Link
56864	7405	" Hook (large)
56865	20795	" " (small)
42130	7389	Lifting Lever
42131	2266	" " Bracket
1229c	5542	" " " Screw
1301d	7389	" " Hinge Screw
42132	7389	" " Spring
1148f	7389	" " Stop Screw
1547j	5543	" " " " Nut
4881	5564	Treadle
4882	2274	" Shaft
4883	2274	" Spring
4884	5564	" Stand
4885	5564	Treadle, complete, Nos. 4879, 4881 to 4884 and two wood screws 1" No. 16
42133	—	Foot Lifter, complete, Nos. 1301d, 4885, 6439, 42130 to 42132, two each 1148f, 1229c and 1547j

FOOT LIFTER

FOR 81K10 MACHINE

No.	Plate	Name
6439	—	Chain, 36" to 45", with 56864 and 56865
<i>NOTE:—When ordering No. 6439, state length required.</i>		
4879	2273	Chain Connecting Link
56864	7405	" Hook (large)
56865	20795	" " (small)

No.	Plate	Name
42130	7389	Lifting Lever
42247	7389	" " Bracket
1229c	5542	" " " Screw
1301d	7389	" " Hinge Screw
42132	7389	" " Spring
1148f	7389	" " Stop Screw
1547j	5543	" " " " Nut
4881	5564	Treadle
4882	2274	" Shaft
4883	2274	" Spring
4884	5564	" Stand
4885	5564	Treadle, complete, Nos. 4879, 4881 to 4884 and two wood screws 1" No. 16
42248	—	Foot Lifter, complete, Nos. 1301d, 4885, 6439, 42130, 42132, 42247, two each 1148f, 1229c and 1547j

FOOT LIFTER

FOR 81K12, 81K14 AND 81K24 MACHINES

No.	Plate	Name
6439	—	Chain, 36" to 45", with 56864 and 56865
<i>NOTE.—When ordering No. 6439, state length required.</i>		
4879	2273	Chain Connecting Link
56864	7405	" Hook (large)
56865	20795	" " (small)
42281	2273	Lifting Lever
42282	2266	" " Bracket
1288r	2274	" " " Screw
1301d	7389	" " Hinge Screw
25033	2274	" " Spring
440f	5543	" " Stop Screw
1547j	5543	" " " " Nut
4881	5564	Treadle
4882	2274	" Shaft
4883	2274	" Spring
4884	5564	" Stand
4885	5564	Treadle, complete, Nos. 4879, 4881 to 4884 and two wood screws 1" No. 16
42283	—	Foot Lifter, complete, Nos. 440f, 1288r, 1301d, 1547j, 4885, 6439, 25033, 42281 and 42282

Guide (Hinged)

FOR 81K20 MACHINE

No.	Plate	Name
42134	7400	Guide with 19015
19015	5543	" Handle
42135	7400	" Holder
1425j	7400	" Hinge Screw
42436	7400	" " " Friction Washer
42437	—	Guide (hinged), complete, Nos. 1425j and 42434 to 42436
42288	5599	Presser Foot Chaining-off Finger
233d	5530	" " " " Screw
42405	—	" " Plate (back)
9320	—	" " " (") Hinge Pin
14058	2276	" " " (") Spring
42160	2273	" " " (") " Adjusting Pin
464c	2276	" " " (") " " " Set Screw
42438	—	" " " (front)
42461	7397	" " " (") Hinge Pin
42264	—	" " Shank
42439	7102	Presser Foot (spring hinged), complete, Nos. 233d, 464c, 9320, 14058, 42160, 42264, 42288, 42405, 42438 and 42461, for 42437

Hemmer

FOR 81K10 MACHINE

No.	Plate	Name
35864	2271	Hemmer on Shank, for $\frac{1}{2}$ " hem, for blankets
217f	5556	" Screw
7071	5595	" " Washer
35865	2272	Presser Foot for 35864

Knee Lifters

KNEE LIFTER

FOR 81K1 TO 81K9, 81K11, 81K13, 81K16 AND 81K20 TO 81K22
MACHINES

No.	Plate	Name
42130	7389	Lifting Lever
42131	2266	" " Bracket
1229c	5542	" " " Screw
42142	5564	" " Connecting Rod
1301d	7389	" " Hinge Screw
42132	7389	" " Spring
1148f	7389	" " Stop Screw
1547j	5543	" " " " Nut
2763	5564	Rock Shaft
12242	5564	" " Hanger with two wood screws 1" No. 10
2765	5564	" " Knee Arm
2766	5564	" " " " Hub with 356c
356c	2277	" " " " " Set Screw
2768	---	Rock Shaft Knee Arm, complete, Nos. 2765 to 2767
2767	5564	Rock Shaft Knee Plate with 356c
356c	2277	" " " " " Set Screw
6337	5564	" " Lifting Bracket with two 356c
7125	5564	" " " " Hook
356c	2277	" " " " " Set Screw
356c	2277	" " " " " Set Screw
2770	5564	" " Stop Dog with 356c
356c	2277	" " " " " Set Screw
42143	5564	Rock Shaft, complete, Nos. 2763, 2768, 6337, 7125, two each 2770 and 12242
42144	---	Knee Lifter, complete, Nos. 1301d, 42130 to 42132, 42142, 42143, two each 1148f, 1229c and 1547j

KNEE LIFTER

FOR 81K10 MACHINE

No.	Plate	Name
42130	7389	Lifting Lever
42247	7389	" " Bracket
1229c	5542	" " " Screw

KNEE LIFTERS

No.	Plate	Name
42142	5564	Lifting Lever Connecting Rod
1301d	7389	" " Hinge Screw
42132	7389	" " Spring
1148f	7389	" " Stop Screw
1547j	5543	" " " " Nut
2763	5564	Rock Shaft
12242	5564	" " Hanger with two wood screws 1" No. 10
2765	5564	" " Knee Arm
2766	5564	" " " " Hub with 356c
356c	2277	" " " " " Set Screw
2768	---	Rock Shaft Knee Arm, complete, Nos. 2765 to 2767
2767	5564	Rock Shaft Knee Plate with 356c
356c	2277	" " " " " Set Screw
6337	5564	" " Lifting Bracket with two 356c
7125	5564	" " " " Hook
356c	2277	" " " " " Set Screw
356c	2277	" " " " " Set Screw
2770	5564	" " Stop Dog with 356c
356c	2277	" " " " " Set Screw
42143	5564	Rock Shaft, complete, Nos. 2763, 2768, 6337, 7125, two each 2770 and 12242
42249	---	Knee Lifter, complete, Nos. 1301d, 42130, 42132, 42142, 42143, 42247, two each 1148f, 1229c and 1547j

KNEE LIFTER

FOR 81K12, 81K14 AND 81K24 MACHINES

No.	Plate	Name
42281	2273	Lifting Lever
42282	2266	" " Bracket
1288r	2274	" " " Screw
1301d	7389	" " Hinge Screw
17886	2273	" " Pitman
25033	2274	" " Spring
440f	5543	" " Stop Screw
1547j	5543	" " " " Nut
2763	5564	Rock Shaft
12242	5564	" " Hanger with two wood screws 1" No. 10

No.	Plate	Name
2765	5564	Rock Shaft Knee Arm
2766	5564	" " " " Hub with 356c
356c	2277	" " " " " Set Screw
2768	---	Rock Shaft Knee Arm, complete, Nos. 2765 to 2767
2767	5564	Rock Shaft Knee Plate, with 356c
356c	2277	" " " " " Set Screw
6337	5564	" " Lifting Bracket with two 356c
7125	5564	" " " " " Hook
356c	2277	" " " " " " Set Screw
356c	2277	" " " " " " Set Screw
2770	5564	" " Stop Dog with 356c
356c	2277	" " " " " " Set Screw
42143	5564	Rock Shaft, complete, Nos. 2763, 2768, 6337, 7125, two each 2770 and 12242
42284	---	Knee Lifter, complete, Nos. 410f, 1288r, 1301d, 1517j, 17886, 25033, 42143, 42281 and 42282

Knife Grinders

KNIFE GRINDER

FOR 81K1 TO 81K9, 81K11 AND 81K20 TO 81K22 MACHINES

No.	Plate	Name
41326	5568	Emery Wheel
1508c	5569	" " Clamping Nut
41327	5568	" " Shaft
41328	5568	" " " Pulley with 1036c
1036c	5569	" " " " " Set Screw
41513	5569	" " Washer
41329	5567	Frame with 1036c
878d	5569	" Oil Hole Stop Screw
41330	5568	Knife Holder with two 14222
150209	---	" " 41330 with 970d, 41331, 41332, two each 313c, 771d, 1519j, 41333 and 41334
41331	5568	" " Bracket with 157e
157e	5569	" " " Clamping Screw
42065	5569	" " " Hinge Stud
1036c	5569	" " " " " Set Screw
717c	5569	" " " Stop Screw
1520e	5569	" " " " " Nut
41333	5569	" " Clamp
41334	5569	" " Spring

No.	Plate	Name
14222	5569	Knife Holder Clamp Steady Pin
771d	5569	" " " Thumb Screw
970d	5569	" " Regulating Thumb Screw
313c	5569	" " Screw Centre
1519j	5569	" " " " Nut
41332	5569	" " Spring
41335	---	Knife Grinder, complete, Nos. 717c, 1508c, 1520e, 41326 to 41329, 42065, 150209, two each 878d, 41513 and three wood screws 1 $\frac{1}{4}$ " No. 12

KNIFE GRINDER

FOR 81K7, 81K23 AND 81K24 MACHINES

No.	Plate	Name
41326	5568	Emery Wheel
1508c	5569	" " Clamping Nut
41327	5568	" " Shaft
41328	5568	" " " Pulley with 1036c
1036c	5569	" " " " " Set Screw
41513	5569	" " Washer
41329	5567	Frame with 1036c
878d	5569	" Oil Hole Stop Screw
41818	5568	Knife Holder with two 14222
150210	---	" " 41818 with 970d, 41331, 41332 and two each 313c, 771d, 1519j, 41333 and 41334
41331	5568	" " Bracket with 157e
157e	5569	" " " Clamping Screw
42065	5569	" " " Hinge Stud
1036c	5569	" " " " " Set Screw
717c	5569	" " " Stop Screw
1520e	5569	" " " " " Nut
41333	5569	" " Clamp
41334	5569	" " Spring
14222	5569	" " Steady Pin
771d	5569	" " Thumb Screw
970d	5569	" " Regulating Thumb Screw
313c	5569	" " Screw Centre
1519j	5569	" " " " Nut
41332	5569	" " Spring
41819	---	Knife Grinder, complete, Nos. 717c, 1508c, 1520e, 41326 to 41329, 42065, 150210, two each 878d, 41513 and three wood screws 1 $\frac{1}{4}$ " No. 12

Thread Unwinders

THREAD UNWINDER

FOR ONE SPOOL

FOR 81K24 MACHINE

No.	Plate	Name
225259	20799	Spool Rest with 201018c
150203	20799	" " Cushion (felt)
150078	20799	" " Rod
200383c	20795	" " " Set Screw
201018c	20795	" " Set Screw
202490	20799	" Stand with 200383c
150079	20799	Thread Guide with 208e
208e	2277	" " Screw
150080	20799	Thread Unwinder, complete, Nos. 150078, 150079, 150203, 202490, 225259 and three wood screws $\frac{3}{8}$ " No. 12
27739	7234	Thread Cone (wood) for large cones
225390	7234	" " Holder, for inverted cones

NOTE.—Nos. 27739 and 225390 are used with but not included in 150080

THREAD UNWINDER

FOR THREE SPOOLS

FOR 81K1 TO 81K8, 81K10 TO 81K14, 81K16 AND 81K22 MACHINES

No.	Plate	Name
225259	20801	Spool Rest (for one spool) with 201018c
225257	20801	" " (for two spools) with 201018c
150203	20801	" " Cushion (felt)
225388	20801	" " Rod
200383c	20795	" " " Set Screw
201018c	20795	" " Set Screw
202490	20801	" Stand with 200383c
225391	20801	Thread Guide
201696j	2276	" " Lock Nut
225326	2273	" " Position Cap
225324	20801	" " Rod with 208e and 225322

No.	Plate	Name
208e	2277	Thread Guide Rod Screw
225322	2276	" " " Washer
259143	20801	Thread Unwinder, complete, Nos. 201696j, 202490, 225257, 225259, 225324, 225326, 225388, three each 150203, 225391 and wood screws $\frac{3}{8}$ " No. 12
27739	7234	Thread Cone (wood) for large cones
225390	7234	" " Holder for inverted cones

NOTE.—Nos. 27739 and 225390 are used with but not included in 259143.

THREAD UNWINDER

FOR THREE SPOOLS

FOR 81K9, 81K20 AND 81K21 MACHINES

Same as No. 259143 with the following additions :

No.	Plate	Name
*150057	---	Thread Separator
150058	20778	" " 150057 with 150059
*150059	---	Bracket
150060	20778	" " " Arm with 164j and 9525
164j	2277	" " " Clamping Screw
9525	2276	" " " " " Washer
164j	2277	" " " Screw
9525	2276	" " " " " Washer
150061	---	Thread Separator, complete, Nos. 164j, 9525, 150058 and 150060
150178	20778	Thread Unwinder, complete, Nos. 150061, 201696j, 202490, 225257, 225259, 225324, 225326, 225388, three each 150203, 225391 and wood screws $\frac{3}{8}$ " No. 12

Welt Guide

FOR 81K3 AND 81K6 MACHINES

only supplied when specified on order

No.	Plate	Name
42473	—	Welt Guide
42475	—	" " Hinge (female half)
42476	—	" " " (male half)
42474	—	" " " Pin
42477	—	" " " Rivet
42478	—	" " Spring
132869	—	" " " 42478, with 42475 and two 42477
42188	5539	Welt Guide (hinged), complete, Nos. 42473, 42474, 42476, 132869 and two 42477
42187	5539	Welt Guide (solid)
42189	5539	" " Holder
1209c	5539	" " " Screw
19044	5539	" " " Washer
1117d	5539	" " Regulating Thumb Screw
190d	5556	" " Screw